

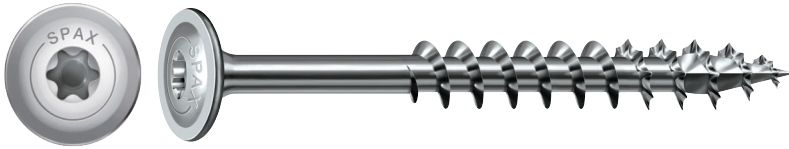

T-STAR *plus* Wafer Head HCR-X™



Multi-Material Wafer Head



MADE IN USA
WITH GLOBALLY
SOURCED MATERIALS

DESCRIPTION

SPAX® T-STAR *plus* Wafer Head fasteners with HCR-X™ coating are designed for use in multiple material connections often found outside residential dwellings. These fasteners are designed with a low profile large diameter wafer head for applications requiring additional surface area under the head for superior pull-down force. Ideal for attaching rail, fencing and out building hardware where a flush or countersunk installation is not possible or desired.

MATERIALS & COATING

Cold-rolled “carbon steel” wire heat treated and plated with a HCR-X™ finish to prevent red rust. “HCR-X™” is tested and recognized for use in ground contact pressure treated lumber for exterior, freshwater general construction applications (e.g., AWWA UC1-UC4A, UCFA). SPAX® recommends stainless steel fasteners for applications with cedar and redwoods.



Low Profile Wafer Head

Provides a larger surface area and aesthetically clean look for the reliable installation of fine cabinetry.



Unique 4CUT™ Point

Prevents splitting and requires no pre-drilling in wood.



Patented Serrations

Allow for quicker, easier fastening.
U.S. Patent No. 7,101,133



T-STAR *plus* Drive

“The Pro’s Choice” drive system provides superior bit engagement, eliminates camming out and facilitates overhead driving.

EXTERIOR



TYPICAL EXTERIOR APPLICATIONS

- Treated lumber rail and gate hardware attachment
- Other exterior applications where substrate must be tightly connected to treated lumber
- Outdoor furniture
- Outdoor play structures
- Window installation



T-STAR plus Wafer Head HCR-X™



Multi-Material Wafer Head

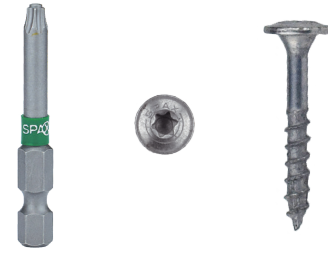
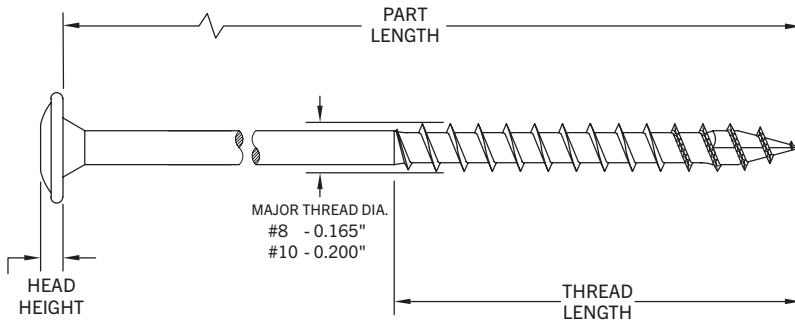

PRODUCT SELECTION

PART LENGTH	THREAD LENGTH		HEAD DIA. HEAD HT.	DRIVE/BIT SIZE	APPROX. QTY.	PKG. TYPE	MASTER QTY.	PART NO.
	FULL	PARTIAL						
#8 x 1-1/4"	N/A	0.670"	0.375" 0.080"	T20+	195	1 lb. Box	5	4281670400324
					2500	Bulk Pail	N/A	3281670400320
#8 x 1-1/2"	N/A	0.875"	0.375" 0.080"	T20+	165	1 lb. Box	5	4281670400404
					495	3 lb. Box	3	4281670400405
					2500	Bulk Pail	N/A	3281670400400
#8 x 2"	N/A	1.250"	0.375" 0.080"	T20+	140	1 lb. Box	5	4281670400504
					1500	Bulk Pail	N/A	3281670400500
#8 x 2-1/2"	N/A	1.375"	0.375" 0.080"	T20+	120	1 lb. Box	5	4281670400604
					1500	Bulk Pail	N/A	3281670400600
#10 x 2-1/2"	N/A	1.500"	0.470" 0.085"	T20+	77	1 lb. Box	5	4281670500604
					1200	Bulk Pail	N/A	3281670500600
#10 x 3"	N/A	1.625"	0.470" 0.085"	T20+	63	1 lb. Box	5	4281670500754
					185	3 lb. Box	3	42816705007545
					1000	Bulk Pail	N/A	3281670500750

NOTE: Only sold in master cartons.

EXTERIOR



1 and 3 lb. Box



Bulk Pail



T-STAR plus Bit



T-STAR plus Wafer Head HCR-X™



Multi-Material Wafer Head

BIT SELECTION

DRIVE BIT	BIT SIZE	MASTER QTY.	PART NO.
T20+	1"	10	5000009185209
	2"	10	5000009285209

NOTE: Only sold in master cartons. Made in Taiwan.



FASTENER LENGTHS

PART LENGTH	HEAD	FASTENER	PART LENGTH	HEAD	FASTENER
#8 x 1-1/4"			#8 x 2-1/2"		
#8 x 1-1/2"			#10 x 2-1/2"		
#8 x 2"			#10 x 3"		

MASONRY & CONCRETE PRE-DRILL SPECIFICATIONS

NOTE: In masonry/concrete, pre-drill a hole at least 1/4" to 1/2" longer than the length of the screw (refer to chart). No anchor required. In sheet metal, no pre-drilling is required up to 24 gauge.

SCREW DIAMETER	DRILL BIT	WEIGHT
#8	1/8"	Light
#10	5/32"	Medium

PERFORMANCE SPECIFICATIONS



TER No. 2010-02
Construction Screw Properties

DIAMETER	ALLOWABLE WITHDRAWAL (W) AND HEAD PULL-THROUGH (W _H) ^{1,2,3,4}					
	SOUTHERN PINE (SG=0.55)		DOUGLAS-FIR (SG=0.50)		HEM FIR & SPRUCE-PINE-FIR (SG=0.42)	
	WITHDRAWAL W (lbs./inch)	HEAD PULL-THROUGH W _H (lbs.)	WITHDRAWAL W (lbs./inch)	HEAD PULL-THROUGH W _H (lbs.)	WITHDRAWAL W (lbs./inch)	HEAD PULL-THROUGH W _H (lbs.)
#8	175	335	133	297	127	268
#10	190	461	176	387	144	338

DIAMETER	ALLOWABLE WITHDRAWAL (W) AND HEAD PULL-THROUGH (W _H) ^{1,2}											
	PLYWOOD 15/32" (0.39)		PLYWOOD 19/32" (0.39)		PLYWOOD 23/32" (0.50)		OSB 15/32" (0.50)		OSB 19/32" (0.50)		OSB 23/32" (0.50)	
	WITHDRAWAL W (lbs./inch)	HEAD PULL-THROUGH W _H (lbs.)	WITHDRAWAL W (lbs./inch)	HEAD PULL-THROUGH W _H (lbs.)	WITHDRAWAL W (lbs./inch)	HEAD PULL-THROUGH W _H (lbs.)	WITHDRAWAL W (lbs./inch)	HEAD PULL-THROUGH W _H (lbs.)	WITHDRAWAL W (lbs./inch)	HEAD PULL-THROUGH W _H (lbs.)	WITHDRAWAL W (lbs./inch)	HEAD PULL-THROUGH W _H (lbs.)
#8	51	146	83	190	162	319	36	86	48	110	52	131
#10	90	183	92	246	186	322	54	87	54	126	66	131

¹ Tabulated withdrawal and head pull-through design values (W) and (W_H) are shown at a C_p = 1.0. Tabulated withdrawal and head pull-through values shall be adjusted by all applicable adjustment factors per *NDS Table 11.3.1*.

² Full withdrawal strength is calculated by multiplying the length of thread embedded in the main member by the tabulated reference withdrawal values.

³ Head pull-through values for #8 diameter and larger in Southern Pine, Douglas-Fir, Hem-Fir and Spruce-Pine-Fir are minimum 1.5" side member thickness.

⁴ For wood species with an assigned specific gravity between 0.42 and 0.50, use the tabulated values for specific gravity of 0.42. For wood species with an assigned specific gravity between 0.50 and 0.55, use the tabulated values for specific gravity of 0.50. For wood species with an assigned specific gravity greater than or equal to 0.55, use the tabulated values for specific gravity of 0.55.

DIAMETER	BENDING YIELD STRENGTH ¹ , f _{yb} (psi)	ALLOWABLE STEEL STRENGTH (lbs)	
		TENSILE	SHEAR ²
#8	187,000	460	345
#10	187,000	690	545

¹ Bending yield strength, f_{yb}, is determined in accordance with *ASTM F1575* using minor thread diameter when fastener is tested in thread section.

² Shear strength is determined in accordance with *AISI S904* using minor thread diameter when fastener is tested in threaded section.



Multi-Material Wafer Head

DIAMETER	REFERENCE LATERAL SHEAR VALUE ^{4,5,6} , Z (lbf)				
	MINIMUM MAIN MEMBER PENETRATION ¹ (in)	MINIMUM SIDE MEMBER THICKNESS (in)	WOOD SPECIES (SPECIFIC GRAVITY ^{2,3})		
			SP (0.55)	DF-L (0.50)	SPF/HF (0.42)
#8 x 1-1/2"	3/4"	3/4"	70	59	43
#8 x 2"	1-1/4"	3/4"	80	70	55
#8 x 2-1/2"	1"	1-1/2"	84	75	58
#10 x 2-1/2"	1"	1-1/2"	115	101	81
#10 x 3"	1-1/2"	1-1/2"	132	121	103

SI: 1 in = 25.4 mm, 1 lbf = 4.45 N

¹ Penetration depth includes the length of tapered tip.

² The species applies to both the main and the side members. Where the Members are different specific gravities, use the lower of the two.

³ For wood species with an assigned specific gravity between 0.42 and 0.50, use the tabulated values for specific gravity of 0.42. For wood species with an assigned specific gravity between 0.50 and 0.55, use the tabulated values for specific gravity of 0.50. For wood species with an assigned specific gravity greater than or equal to 0.55, use the tabulated values for specific gravity of 0.55.

⁴ The fastener orientation shall be perpendicular to the grain, and the underside of the fastener head shall be installed flush with the surface of the side member.

⁵ Lateral design values apply to both perpendicular grain (Z_{\perp}) and parallel to grain (Z_{\parallel}) orientations.

⁶ Tabulated lateral design values shall be adjusted by all applicable adjustment factors per *NDS 11.3.1*.

EXTERIOR

DIAMETER	REFERENCE LATERAL SHEAR VALUE, Z (lbf)			
	MINIMUM MAIN MEMBER PENETRATION ¹ (in)	MINIMUM SIDE MEMBER THICKNESS (in)	REFERENCE LATERAL SHEAR VALUE ^{1,3,4} , Z (lbf)	
			OSB ⁵ (0.50)	PLYWOOD ⁵ (0.39)
#8 x 1-1/4"	13/16"	7/16"	40	-
#8 x 1-1/4"	25/32"	15/32"	40	33
#8 x 1-1/4"	21/32"	19/32"	42	32
#8 x 1-1/2"	1-1/16"	7/16"	51	-
#8 x 1-1/2"	1-1/32"	15/32"	50	44
#8 x 1-1/2"	29/32"	19/32"	49	41
#8 x 1-1/2"	25/32"	23/32"	51	39
#8 x 2"	1-9/16"	7/16"	53	-
#8 x 2"	1-17/32"	15/32"	54	46
#8 x 2"	1-13/32"	19/32"	59	48
#8 x 2"	1-9/32"	23/32"	64	51
#8 x 2-1/2"	1-5/16"	7/16"	51	46
#8 x 2-1/2"	1-9/32"	15/32"	52	48
#8 x 2-1/2"	1-5/32"	19/32"	57	51
#10 x 2-1/2"	2-1/16"	7/16"	80	-
#10 x 2-1/2"	1-17/32"	15/32"	81	70
#10 x 2-1/2"	1-29/32"	19/32"	85	72
#10 x 2-1/2"	1-25/32"	23/32"	90	74

SI: 1 in = 25.4 mm, 1 lbf = 4.45 N

¹ Reference lateral design values apply to two-member single shear connections where the side member is OSB or plywood, the main member is SPF (SG = 0.42), and the fastener is installed in the face of the member and oriented perpendicular to the grain. The underside of the fastener head shall be installed flush with the surface of the side member.

² Penetration depth includes the length of the tapered tip.

³ Lateral design values apply to both perpendicular to grain (Z_{\perp}) and parallel to grain (Z_{\parallel}) orientations.

⁴ Tabulated lateral design values shall be adjusted by all applicable adjustment factors per *NDS Table 11.3.1*.

⁵ OSB shall comply with *DOC PS 2* and have a minimum specific gravity of 0.50. Plywood shall comply with *DOC PS 1* and have a minimum specific gravity of 0.39.