

Beam Clamps



Our beam attachments and pipe supports offered in this section are designed to provide supports without drilling or welding. A complete selection of beam clamps, pipe clamps, rollers, supports and accessories are designed for use with our channels and offer many installation advantages.

Materials & Finishes (Unless otherwise noted)

Pipe clamps, pipe hangers, beam clamps, brackets, and rollers are made from low carbon steel strips, plates or rod unless noted.

Note: A minimum order may apply on special material and finishes.

Load Data

The load data published includes a safety factor of 5.0 unless noted (safety factor = ratio of ultimate load to the design load).

Recommended Torque For Setscrews (unless noted)

See chart on page 106 for recommended torquing of bolts (not setscrews).

Metric

Metric dimensions are shown in parentheses. Unless noted, all metric dimensions are in millimeters.

Finish Code	Finish	Specification
PLN	Plain	ASTM A1018 Gr. 33 ASTM A1011 SS Grade 33
ZN	Electro-Plated Zinc	ASTM B633 SC3 Type III or ASTM A653
GRN	DURA GREEN™	
-	Malleable Iron	ASTM A47 Gr. 32510
HDG	Hot-Dipped Galvanized	ASTM A123
CZ	Chromium Zinc	ASTM F1136 Gr. 3
SS4	Stainless Steel Type 304	ASTM A240
SS6	Stainless Steel Type 316	ASTM A240
AL	Aluminum	ASTM B209

Setscrew Size	1/4"-20	3/8"-16	1/2"-13
ft-lbs	4	5	11
Nm	5	7	15

Setscrew Size	5/8"-11	3/4"-10
ft-lbs	21	34
Nm	28	46

Beam Clamps

B211 Zee Beam Clamp

- Design Load 600 Lbs. (2.67 kN) when used in pairs
- Safety Factor of 5
- 1" (25.4) Max. flange thickness
- 1/2"-13 Setscrew included
- Sold in pieces
- Order 1/2"-13 HHCS and channel nut separately
- Standard finishes: ZN, HDG
- Wt./C 66 Lbs. (29.9 kg)

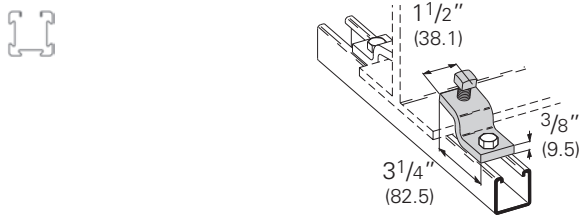

B213 I-Beam Clamp

- Design Load 900 Lbs. (4.00 kN) when used in pairs
- Safety Factor of 5
- 7/8" (22.2) Max. flange thickness
- 1/2"-13 Setscrew included
- Sold in pieces
- Order 1/2"-13 x 2 1/4" HHCS and channel nut separately
- Material: Malleable iron
- Standard finishes: ZN, GRN
- Wt./C 95 Lbs. (43.1 kg)

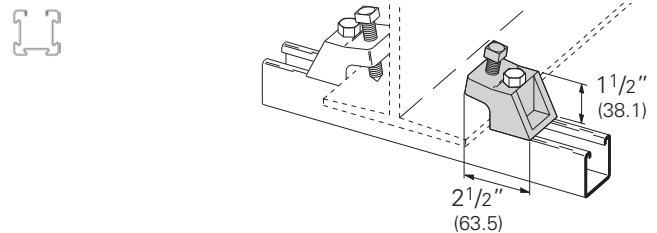

B355 Beam Clamp

- Design Load 1200 Lbs. (5.34 kN) when used in pairs
- Safety Factor of 5
- 5/8" (15.9) Max. flange thickness
- Sold in pieces
- Order 1/2"-13 x 1 1/2" HHCS and channel nut separately
- Standard finishes: ZN, GRN, HDG, SS4
- Wt./C 30 Lbs. (13.6 kg)

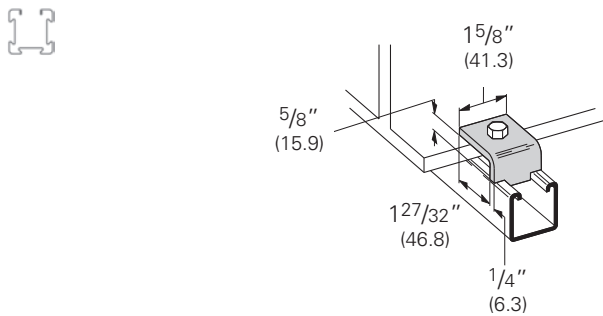

B212-1/4 I-Beam Clamp

- Design Load 600 Lbs. (2.67 kN) when used in pairs
- Safety Factor of 5
- 7/8" (22.2) Max. flange thickness
- 3/8"-16 Setscrew included
- Sold in pieces
- Standard finish: ZN
- Wt./C 41 Lbs. (18.6 kg)

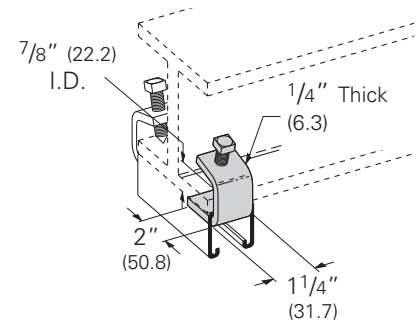

B212-3/8 I-Beam Clamp

- Design Load 1000 Lbs. (4.45 kN) when used in pairs
- Safety Factor of 5
- 1 1/8" (28.6) Max. flange thickness
- 1/2"-13 Setscrew included
- Sold in pieces
- Standard finishes: ZN, HDG
- Wt./C 62 Lbs. (28.1 kg)

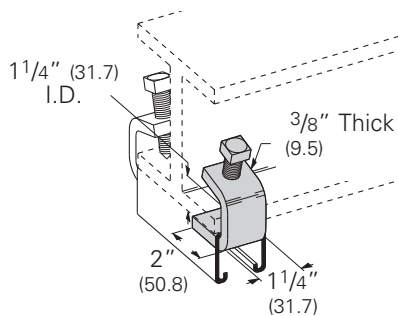

B435 Beam Clamp

- Design Load 900 Lbs. (4.00 kN) when used in pairs
- Safety Factor of 5
- 2 1/8" (54.0) Max. flange thickness
- 1/2"-13 x 2" Setscrew included
- Sold in pieces
- Standard finish: ZN
- Wt./C 82 Lbs. (37.2 kg)

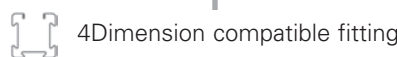
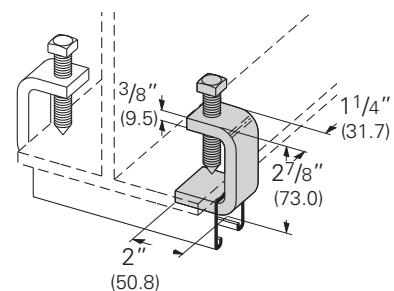

Reference page 154 for general fitting and standard finish specifications.