

EXPLANATION OF GENERAL VIEW

No.	NAME	No.	NAME
1	L.BOLT 8*18	33	SCREW ST 4*63
2	UP FLANGE	34	STATOR
3	DOWN FLANGE	35	MOTOR HOUSING
4	SCREW M4*12	36	WIRE GUARD
5	SCREW M4*12	37	REAR COVER
6	BEARING FLANGE	38	SCREW ST 4*14
7	LEVER	39	BRUSH HOLDER
8	WHEEL GUARD	40	SCREW ST 3*10
9	BUSH $\phi 20 \times \phi 15 \times 5.5$	41	CARBON BRUSH
10	BEARING 6202	42	SCREW ST 5*23
11	SCREW M5*16	43	SCREW ST 4*14
12	SPRING	44	SWITCH HANDLE (L)
13	BEARING HOUSING	45	SWITCH
14	SPINDLE	46	CABLE FLANGE
15	WOODROOF KEY 3*10	47	SWITCH HANDLE (R)
16	SCREW M5*22	48	CABLE SLEEVE
17	LEVER BASE	49	CABLE
18	SCREW M4*8	50	SCALE
19	NUT $\phi 8$	51	SCREW M6*16
20	LEVER FLANGE	52	NUT $\phi 6$
21	GEAR	53	WASHER $\phi 14 \times \phi 6 \times 2$
22	BEARING 607	54	ADJUSTING SHAFT
23	GEARBOX	55	LEVER
24	BEARING 6001	56	WASHER $\phi 17 \times \phi 8 \times 2$
25	INN SPRING	57	NUT $\phi 6$
26	BRAKER	58	FIX STAND
27	ARMATURE	59	ADJUSTING NUT
28	WASHER	60	ROD SCREW
29	BEARING 608	61	SCREW M6*16
30	WASHER $\phi 22 \times \phi 15 \times 0.5$	62	SCREW M6*20
31	BEARING SLEEVE 608	63	NUT $\phi 6$
32	FAN GUARD	64	ALUMINIUM BASE

OPERATING MANUAL

CIRCULAR SAW

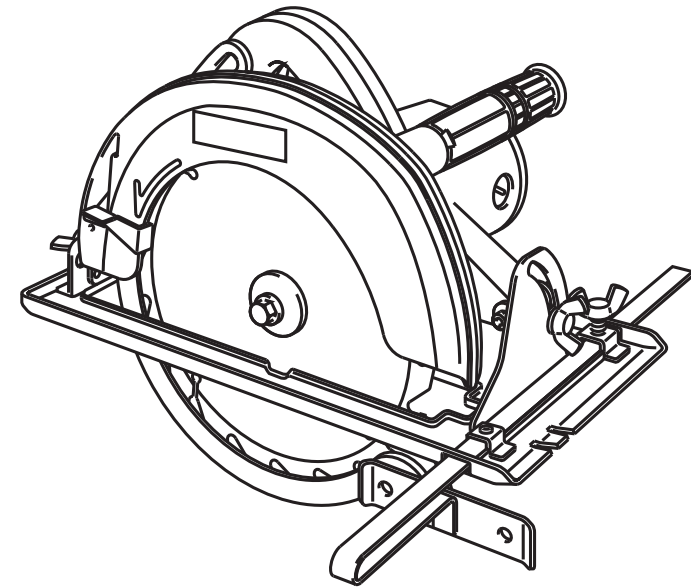

180SL/185SL
185A/185B/MT583



Read through carefully and understand these instructions before use.

GENERAL SAFETY RULES

(For All Tools)

WARNING! Read and understand all instructions. Failure to follow all instructions listed below may result in electric shock, fire and/or serious personal injury.

Work Area

1. **Keep work area clean and well lit.** Cluttered areas and benches invite injuries.
2. **Do not operate power tools in explosive atmospheres, such as in the presence of flammable liquids, gases, or dust.** Power tools create sparks which may ignite the dust or fumes.
3. **Keep bystanders, children, and visitors away while operating a power tool.** Distractions can cause you to lose control.

Electrical Safety

4. **Power tools must be plugged into an outlet properly installed or grounded in accordance with all codes and ordinances.** Never modify the plug in any way. Do not use any adaptor plugs with grounded (earthed) power tools. The original plug and proper outlet may reduce the risk of electric shock.
5. **Avoid body contact with grounded surfaces such as pipes, radiators, ranges and refrigerators.** There is an increased risk of electric shock if your body is grounded.
6. **Do not expose power tools to rain or wet conditions.** Water entering a power tool will increase the risk of electric shock.
7. **Do not abuse the cord. Never use the cord to carry the tools or pull the plug from an outlet. Keep cord away from heat, oil, sharp edges or moving parts.** Replace damaged cords immediately. Damaged or entangled cords increase the risk of electric shock.
8. **When operating a power tool outside, use only extension cords intended for outdoors use.** These cords may reduce the risk of electric shock.

Personal Safety

9. **Stay alert, watch what you are doing and use common sense when operating a power tool. Do not use tool while tired or under the influence of drugs, alcohol, or medication.** A moment of inattention while operating power tools may result in serious personal injury.
10. **Dress properly. Do not wear loose clothing or jewelry. Contain long hair. Keep your hair, clothing, and gloves away from moving parts.** Loose clothes, jewelry, or long hair can be caught in moving parts.
11. **Avoid accidental starting. Be sure switch is off before plugging in.** Carrying tools with your finger on the switch or plugging in tools that have the switch on invites accidents.
12. **Remove adjusting keys or wrenches before turning the tool on.** A wrench or a key that is left attached to a rotating part of the tool may result in personal injury.
13. **Do not overreach. Keep proper footing and balance at all times.** Proper footing and balance enables better control of the tool in unexpected situations.
14. **Use safety equipment. Always wear eye protection.** Dust mask, non-skid safety shoes, hard hat, or hearing protection must be used for appropriate conditions. Ordinary eye or sun glasses are NOT eye protection.
15. **If devices are provided for the connection of dust extraction and collection facilities, ensure these are connected and properly used.** Use of dust collection can reduce dust-related hazards.

Tool Use and Care

16. **Do not force tool. Use the correct tool for your application.** The correct tool will do the job better and safer at the rate for which it is designed.
17. **Do not use tool if switch does not turn it on or off.** Any tool that cannot be controlled with the switch is dangerous and must be repaired.
18. **Disconnect the plug from the power source before making any adjustments, changing accessories, or storing the tool.** Such preventive safety measures reduce the risk of starting the tool accidentally.

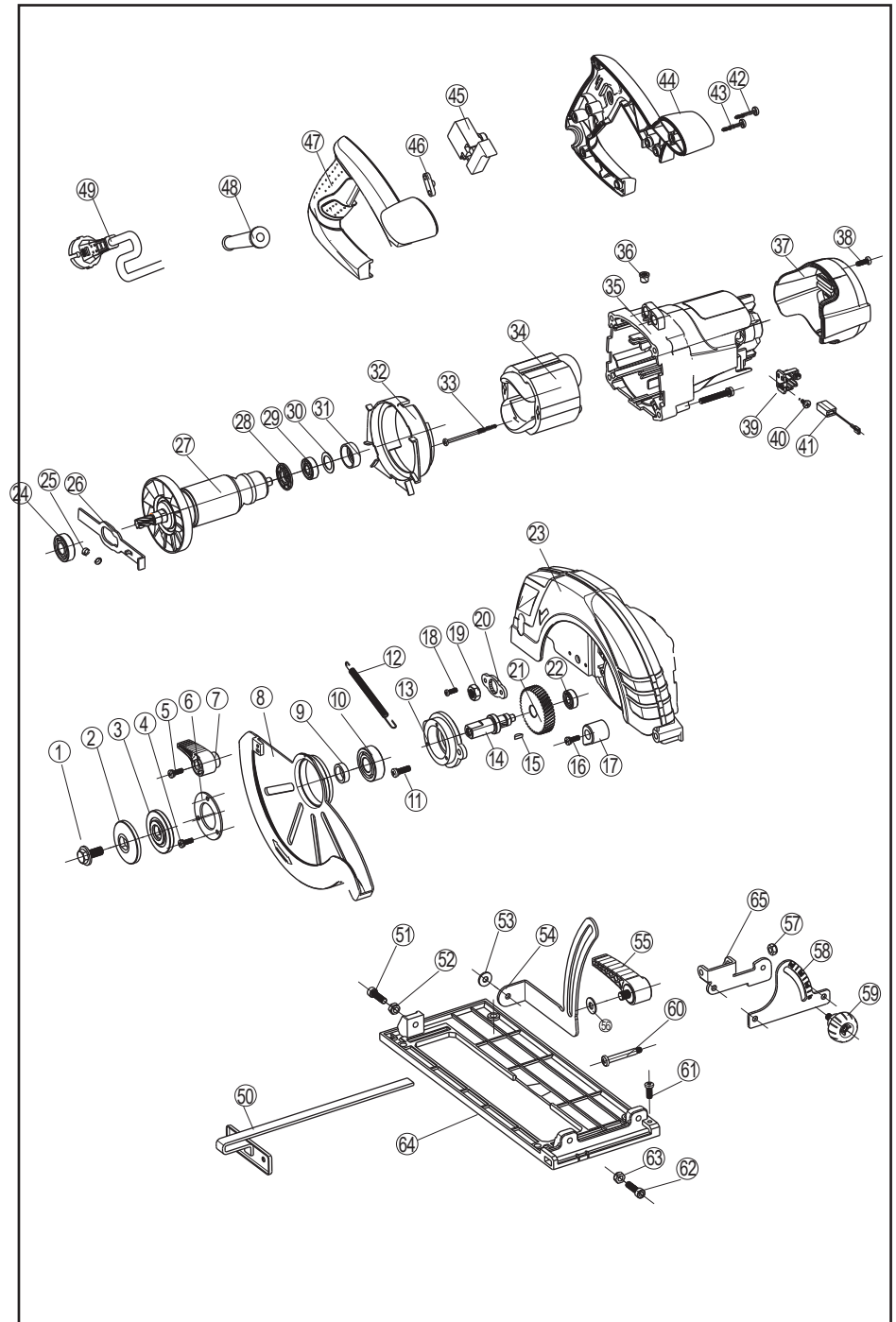

MAINTENANCE AND INSPECTION

CAUTION :

Always be sure that the tool is switched off and unplugged before attempting to perform inspection or maintenance.

Maintenance of the motor

The motor unit winding is the very “heart” of the power tool. Exercise due care to ensure the winding does not become damaged and /or wet with oil or water.

Inspecting the carbon brushes

Remove and check the carbon brushes regularly. Replace when they wear down to the limit mark (Fig. 20). Keep the carbon brushes clean and free to slip in the holders. Both carbon brushes should be replaced at the same time. Use only identical carbon brushes.

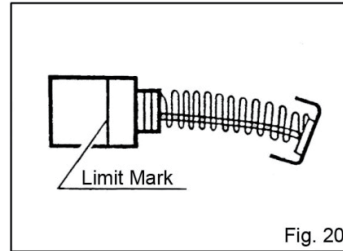

Use a screwdriver to remove the brush holder caps. Take out the worn carbon brushes, insert the new ones and secure the brush holder caps. (Fig. 21)

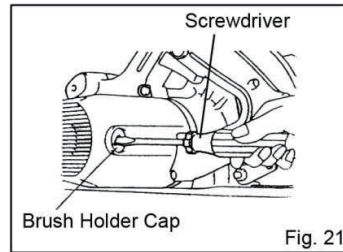

※ To maintain product SAFETY and RELIABILITY, repairs, any other maintenance or adjustment should be performed by authorized service centers, always using original replacement parts.

19. **Store idle tools out of reach of children and other untrained persons.** Tools are dangerous in the hands of untrained users.
20. **Maintain tools with care. Keep cutting tools sharp and clean.** Properly maintained tools with sharp cutting edges are less likely to bind and are easier to control.
21. **Check for misalignment or binding of moving parts, breakage of parts, and any other condition that may affect the tools operation.** If damaged, have the tool serviced before using. Many accidents are caused by poorly maintained tools.
22. **Use only accessories that are recommended by the manufacturer for your model.** Accessories that may be suitable for one tool, may become hazardous when used on another tool.

Service

23. **Tool service must be performed only by qualified repair personnel.** Service or maintenance performed by unqualified personnel could result in a risk of injury.
24. **When servicing a tool, use only identical replacement parts. Follow instructions in the Maintenance section of this manual.** Use of unauthorized parts or failure to follow Maintenance instructions may create a risk of electric shock or injury.

VOLTAGE WARNING:

Before connecting the tool to a power source (receptacle, outlet, etc.), be sure the voltage supplied is the same as that specified on the nameplate of the tool. A power source with voltage greater than that specified for the tool can result in **SERIOUS INJURY** to the user, as well as damage to the tool. If in doubt, **DO NOT PLUG IN THE TOOL**. Using a power source with voltage less than nameplate rating is harmful to the motor.

ADDITIONAL SAFETY RULES

DANGER:

1. Keep hands away from cutting area and blade. Keep your second hand on auxiliary handle, or motor housing. If both hands are holding the saw, they cannot be cut by the blade.
2. Keep your body positioned to either side of the saw blade, but not in line with the saw blade. **KICKBACK** could cause the saw to jump backwards.
3. Do not reach underneath the work. The guard can not protect you from the blade below the work. Do not attempt to remove cut material when blade is moving.

CAUTION: Blades coast after turn off. Wait until blade stops before grasping cut material.

4. Adjust the cutting depth to the thickness of the workpiece. Less than a full tooth of the blade teeth should be visible below the workpiece.
5. **NEVER** hold piece being cut in your hands or across your leg. It is important to support the work properly to minimize body exposure, blade binding, or loss of control.
6. Hold tool by insulated gripping surfaces when performing an operation where the cutting tool may contact hidden wiring or its own cord. Contact with a “live” wire will also make exposed metal parts of the tool “live” and shock the operator.
7. Check lower guard for proper closing before each use. Do not operate saw if lower guard does not move freely and close instantly. Never clamp or tie the lower guard into the open position. If saw is accidentally dropped, lower guard may be bent. Raise the lower guard with the Retracting Lever and make sure it moves freely and does not touch the blade or any other part, in all angles and depths of cut.

To check lower guard, open lower guard by hand, then release and watch guard closure. Also check to see that Retracting Lever does not touch tool housing. Leaving blade exposed is **VERY DANGEROUS** and can lead to serious personal injury.

8. Check the operation and condition of the lower guard spring. If the guard and the spring are not operating properly, they must be serviced before use. Lower guard may operate sluggishly due to damaged parts, gummy deposits, or a buildup of debris.

9. Lower guard should be retracted manually only for special cuts such as "Plunge Cuts" and "Compound Cuts". Raise lower guard by Retracting Lever. As soon as blade enters the material, lower guard must be released. For all other sawing, the lower guard should operate automatically.
10. Always observe that the lower guard is covering the blade before placing saw down on bench or floor. An unprotected, coasting blade will cause the saw to walk backwards, cutting whatever is in its path. Be aware of the time it takes for the blade to stop after switch is released.
11. When ripping always use a rip fence or straight edge guide. This improves the accuracy of cut and reduces the chance for blade binding.
12. Always use blades with correct size and shape (diamond versus round) arbor holes. Blades that do not match the mounting hardware of the saw will run eccentrically, causing loss of control.
13. Never use saw blades made of high-speed steel.
14. Never use damaged or incorrect blade washers or bolts. The blade washers and bolt were specially designed for your saw, for optimum performance and safety of operation.
15. Causes and Operator Prevention of Kickback:
 - Kickback is a sudden reaction to a pinched, bound or misaligned saw blade, causing an uncontrolled saw to lift up and out of the workpiece toward the operator;
 - When the blade is pinched or bound tightly by the kerf closing down, the blade stalls and the motor reaction drives the unit rapidly back toward the operator;
 - If the blade becomes twisted or misaligned in the cut, the teeth at the back edge of the blade can dig into the top surface of the wood causing the blade to climb out of the kerf and jump back toward operator.

Kickback is the result of tool misuse and/or incorrect operating procedures or conditions and can be avoided by taking proper precautions as given below:

- Maintain a firm grip with both hands on the saw and position your body and arm to allow you to resist KICKBACK forces. KICKBACK forces can be controlled by the operator, if proper precautions are taken.
- When blade is binding, or when interrupting a cut for any reason, release the trigger and hold the saw motionless in the material until the blade comes to a complete stop. Never attempt to remove the saw from the work or pull the saw backward while the blade is in motion or KICKBACK may occur. Investigate and take corrective actions to eliminate the cause of blade binding.
- When restarting a saw in the workpiece, center the saw blade in the kerf and check that saw teeth are not engaged into the material. If saw blade is binding, it may walk up or KICKBACK from the workpiece as the saw is restarted.
- Support large panels to minimize the risk of blade pinching and KICKBACK. Large panels tend to sag under their own weight. Supports must be placed under the panel on both sides, near the line of cut and near the edge of the panel. (Fig. 1) To minimize the risk of blade pinching and kickback, when cutting operation requires the resting of the saw on the workpiece, the saw should be rested on the larger portion and the smaller piece cut off. (Fig. 1&2)
- Do not use dull, deformed, cracked or damaged blade. Unsharpened or improperly set blades produce narrow kerf causing excessive friction, blade binding and KICKBACK. Keep blade sharp and clean. Gum and wood pitch hardened on blades slows saw and increases

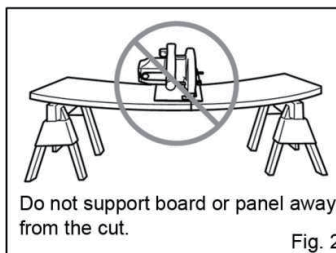
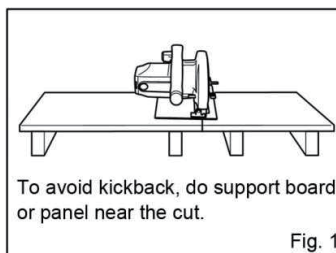

- Do not stop the saw blade by lateral pressure on the disc. Hold the tool firmly. The tool is provided with both a front grip and rear handle. Use both to best grasp the tool. If both hands are holding saw, they cannot be cut by the blade.

Set the base on the workpiece to be cut without the blade making any contact. Then turn the tool on and wait until the blade attains full speed. Now simply move the tool forward over the workpiece surface, keeping it flat and advancing smoothly until the sawing is completed. (Fig. 16)

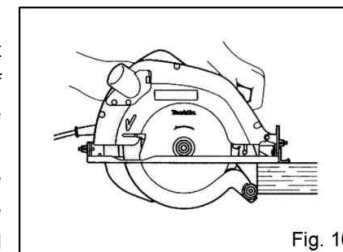

To get clean cuts, keep your sawing line straight and your speed of advance uniform. If the cut fails to properly follow your intended cut line, do not attempt to turn or force the tool back to the cut line. Doing so may bind the blade and lead to dangerous kickback and possible serious injury. Release switch, wait for blade to stop and then withdraw tool. Realign tool on new cut line, and start cut again.

Attempt to avoid positioning which exposes operator to chips and wood dust being ejected from saw. Use eye protection to help avoid injury.

Rip Fence (Guide Rule)

The handy rip fence allows you to do extra-accurate straight cuts. Simply slide the rip fence up snugly against the side of the workpiece and secure it in position with the wing bolt on the front of the base. It also makes repeated cuts of uniform width possible. (Fig. 17)

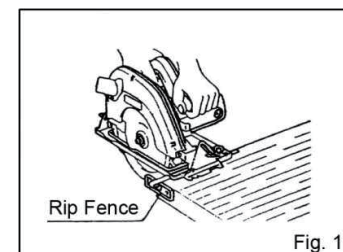

Joint Assembly (for connecting to a vacuum cleaner)

When you wish to perform clean cutting operation, connect a vacuum cleaner to your tool. Install the joint on the tool using the screw. Then connect a hose of a vacuum cleaner to the joint. (Fig.18&19)

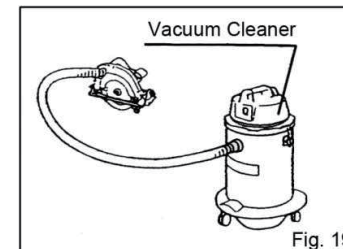
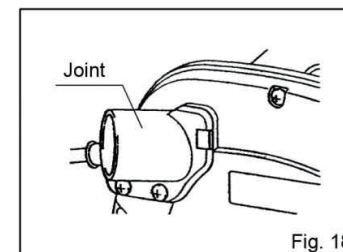

- Do not use saw blades which do not comply with the characteristics specified in these instructions.
- Do not use saw blades the disc of which is thicker or the set of which is smaller than the thickness of the riving knife.
- Be sure the blade is installed with teeth pointing forward in the same direction as the tool rotation (the arrow on the blade should point in the same direction as the arrow on the tool).
- The inner flange is supplied for 2 types of saw blades with the inner diameters of 20 mm and 30 mm. A number "20" is marked on the side with inner diameter of 20 mm, be sure to choose the correct side of the inner flange for installation according to the diameter of the blade. Improper installation may result in dangerous vibration and cause serious personal injury.
- Never depress the shaft lock while the saw is running.
- Use only original wrench to remove or install the blade.
- The following blade can be used with this tool:
- Never depress the shaft lock while the saw is running.
- Use only original wrench to remove or install the blade.
- The following blade can be used with this tool:

Max. Dia.	Min. Dia.	Inner Dia.	Blade Thickness	Kerf
185 mm	170 mm	20 (30) mm	1.7 mm	1.9 mm

The thickness of the riving knife is 1.8 mm.

To remove the blade, press the shaft lock so that the blade cannot revolve and use the hex wrench to loosen the hex socket head bolt counterclockwise. (Fig. 13)

Then remove the hex socket head bolt, outer flange, raise the lower safety guard as much as possible, and remove the saw blade. (Fig. 14)

To install the saw blade, follow the removal procedures in reverse. Install the inner flange, saw blade, outer flange and hex socket head bolt, in that order. (Fig. 15)

Be sure to secure the hex socket head bolt clockwise tightly with the shaft lock fully depressed.

When changing blade, make sure to also clean upper and lower blade guards of accumulated sawdust. Such efforts do not, however, replace the need to check lower guard operation before each use.

Cutting Operation

CAUTION:

- Be sure to move the tool forward in a straight line gently. Forcing or twisting the tool will result in overheating the motor and dangerous kickback, possibly causing severe injury.
- The riving knife should always be used except when plunging in the middle of the workpiece.

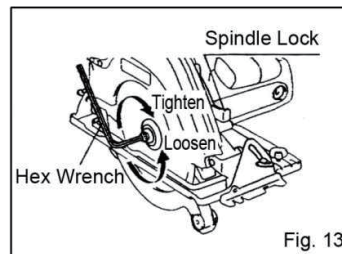

Fig. 13

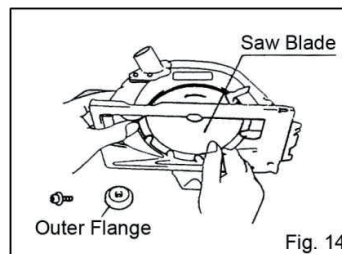

Fig. 14

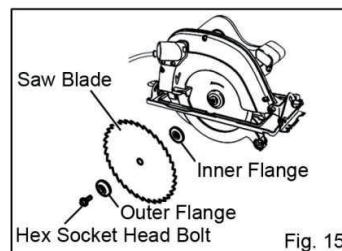

Fig. 15

potential for kickback. Keep blade clean by first removing it from tool, and then cleaning it with gum and pitch remover, hot water or kerosene. Never use gasoline.

- Blade depth and bevel adjusting locking levers must be tight and secure before making cut. If blade adjustment shifts while cutting, it may cause binding and KICKBACK.
- Use extra caution when making a "Plunge Cut" into existing walls or other blind areas. The protruding blade may cut objects that can cause KICKBACK. For plunge cuts, retract lower guard using Retracting Lever.
- ALWAYS hold the tool firmly with both hands. NEVER place your hand or fingers behind the saw. If kickback occurs, the saw could easily jump backwards over your hand, leading to serious personal injury. (Fig. 3)
- Never force the saw. Forcing the saw can cause uneven cuts, loss of accuracy, and possible kickback. Push the saw forward at a speed so that the blade cuts without slowing.

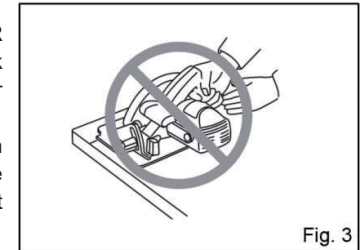

Fig. 3

16. Use the appropriate riving knife for the blade being used. For the riving knife to work, it must be thicker than the body of the blade but thinner than the tooth set of the blade.

17. Adjust the riving knife as described in this instruction manual. Incorrect spacing, positioning and alignment can make the riving knife ineffective in preventing kickback.

18. Always use the riving knife except when plunge cutting. Riving knife causes interference during plunge cutting and can create kickback.

19. For the riving knife to work, it must be engaged in the workpiece. The riving knife is ineffective in preventing kickback during short cuts.

20. Do not operate the saw if riving knife is bent. Even a light interference can slow the closing rate of a guard.

21. Use extra caution when cutting damp wood, pressure treated lumber or wood containing knots. Adjust speed of cut to maintain smooth advancement of tool without decrease in blade speed.

22. Adjustments. Before cutting be sure depth and bevel adjustments are tight.

23. Avoid Cutting Nails. Inspect for and remove all nails from lumber before cutting.

24. When operating the saw, keep the cord away from the cutting area and position it so that it will not be caught on the workpiece during the cutting operation. The tool is provided with a front grip and rear handle for two hand operation. Operate with proper hand support, proper workpiece support, and supply cord routing away from the work area.

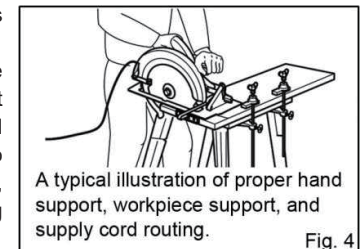

A typical illustration of proper hand support, workpiece support, and supply cord routing.

Fig. 4

WARNING: It is important to support the workpiece properly and to hold the saw firmly to prevent loss of control which could cause personal injury. Fig. 4 illustrates typical hand support of the saw.

25. Place the wider portion of the saw base on that part of the workpiece which is solidly supported, not on the section that will fall off when the cut is made. As examples, Fig. 5 illustrates the RIGHT way to cut off the end of a board, and Fig. 6 the WRONG way.

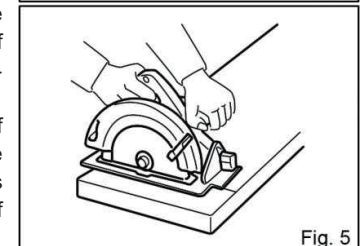

Fig. 5

If the workpiece is short or small, clamp it down. DO NOT TRY TO HOLD SHORT PIECES BY HAND!



26. Never attempt to saw with the circular saw held upside down in a vise. This is extremely dangerous and can lead to serious accidents. (Fig. 7)
27. **WARNING:** Blade coasts to stop after switch is released. Contact with coasting blade can cause serious injury. Before setting the tool down after completing a cut, be sure that the lower (telescoping) guard has closed and the blade has come to a complete stop.
28. Do not stop the blades by lateral pressure on the saw blade.
29. Always use blades recommended in this manual. Do not use any abrasive or grinding wheels.
30. Wear a dust mask and hearing protection when use the tool.
31. Some material contains chemicals which may be toxic. Take caution to prevent dust inhalation and skin contact. Follow material supplier safety data.

SAVE THESE INSTRUCTIONS.

WARNING! MISUSE or failure to follow the safety rules stated in this instruction manual may cause serious personal injury.

INSTRUCTIONS FOR OPERATION

Adjusting Riving Knife

CAUTION:

- Always be sure that the tool is switched off and unplugged before adjusting or checking function on the tool.
- Ensure that the riving knife is adjusted such that:
 - The distance between the riving knife and the toothed rim of the saw blade is not more than 5 mm;
 - The toothed rim does not extend more than 5 mm beyond the lower edge of the riving knife.

Use the hex wrench to loosen the hex socket head bolt for the riving knife adjustment, and then raise the safety cover. Move the riving knife up or down over the two protuberances for settings indicated in the illustration of Fig. 8, so as to obtain the proper clearance between the riving knife and saw blade. (Fig.8)

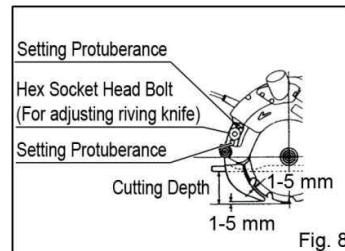

Adjusting Depth of Cut

CAUTION:

- Use a shallow depth of cut when cutting thin workpiece for cleaner, safer cuts.
- After adjusting the depth of cut, always tighten the lever securely.

Hold the handle with one hand and loosen the lever on the depth guide with the other. Move the base up or down. At a desired depth of cut, secure the base by tightening the lever. (Fig. 9)

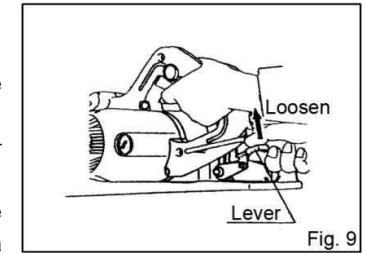

Bevel Cutting

Loosen the wing bolts in front and back, and tilt the tool to the desired angle for bevel cut (0-45°). Secure the wing bolt tightly in front and back after making the adjustment. (Fig.10)

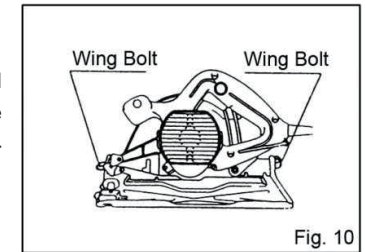

Sighting

For straight cuts, align the right notch on the front of the base with the cutting line on the workpiece. For 45° bevel cuts, align the left notch with it. (Fig. 11)

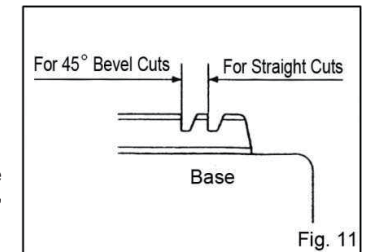

Switch Action

CAUTION:

Before plugging in the tool, always check to see that the switch trigger actuates properly and returns to the "OFF" position when released.

To prevent the switch trigger from being accidentally pulled, a lock-off button is provided as a safety feature. To start the tool, push in the lock-off button and pull the switch trigger. Release the switch trigger to stop. (Fig. 12)

Removing or Installing Saw Blade

CAUTION:

- Always be sure that the tool is switched off and unplugged before installing or removing the saw blade.

