

NOTES:

1. WHEN INSTALLING THIS UNIT, LOCAL, STATE, OR FEDERAL CODES SHOULD BE ADHERED TO. INSTALL A TRAP IN THE WASTE LINE AND A SCREWDRIVER STOP IN THE SUPPLY LINE IF REQUIRED.
2. TO COMPLY WITH ANSI Z358.1-2014 FOR EMERGENCY EYEWASH AND SHOWER EQUIPMENT:
 - UNIT SHALL BE INSTALLED IN ACCORDANCE WITH MANUFACTURER'S INSTRUCTIONS AND ACCEPTABLE PLUMBING PRACTICES.
 - EYEWASH STREAMS SHALL BE POSITIONED SUCH THAT STREAMS ARE 15.3 CM (6 IN.) MINIMUM FROM THE WALL OR NEAREST OBSTRUCTION AND, WHEN FLOWING AT 30-30.5 PSI, MEET ANSI GAUGE REQUIREMENTS BETWEEN 83.8 & 134.6 CM (33-53 IN) ABOVE FLOOR.
 - SHOWER SHALL BE POSITIONED SUCH THAT SHOWERHEAD IS BETWEEN 208.3 & 243.8 CM (82-96 IN.) FROM FLOOR.
 - SHOWER SPRAY PATTERN SHALL HAVE A MINIMUM DIAMETER OF 50.8 CM (20 IN.) AT 152.4 CM (60 IN.) ABOVE SURFACE ON WHICH USER STANDS, AND CENTER OF SPRAY PATTERN SHALL BE LOCATED AT LEAST 40.6 CM (16 IN.) FROM ANY OBSTRUCTION.
3. SPECIFY BURY DEPTH FOR FREEZE RESISTANT VALVE, STANDARD BURY DEPTHS ARE:
 - 24" [610mm] OR 42" [1067mm].
4. HOLD ROUGH-IN DIMENSIONS ±1/2" (12.7mm).

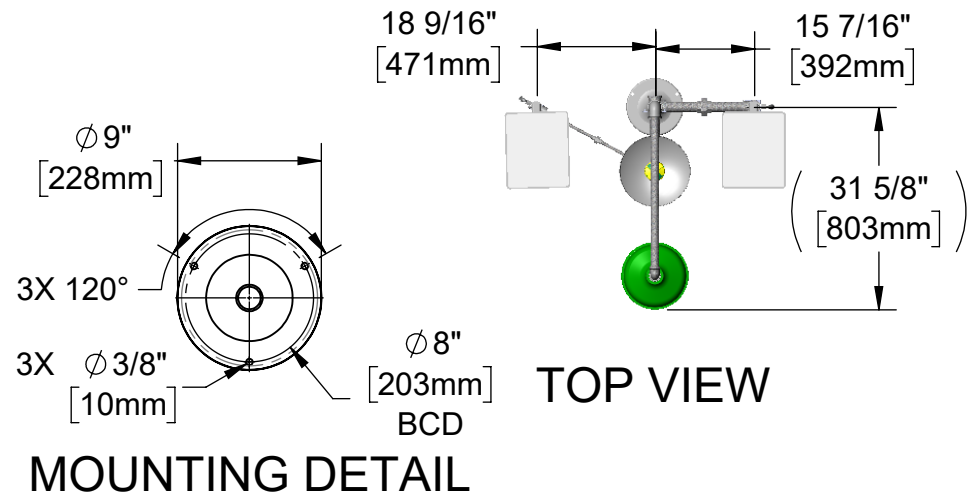

MOUNTING DETAIL

Haws
Since 1906

1455 KLEPPE LANE
SPARKS, NEVADA 89431
(775) 359-4712 FAX (775) 359-7424
E-MAIL: HAWS@HAWS.CO.COM
WEBSITE: WWW.HAWS.CO.COM

ECN: 1499	REV. ECN: 6264	BY: JU	MODEL(S): 8300FP	PART NUMBER: 0002080163.D
DRAWN: JU	DATE: 05/01/25	CHKD: DN		REVISION: 18
APPROVED: JU	DATE: 12/19/25	SCALE: 1:30	DRAWING TYPE: INSTALLATION	SHEET 1 OF 1