



ALPHA MUTT® with ABS

Mobile Universal Trailer Tester



SERVICE-TRUCK MODEL

Set-Up Information • Operator's Manual • Technical Information
For All Models



#5611A-RT8 Alpha MUTT® with ABS, Rugged Tablet and Slide-Out Base

#5611A Alpha MUTT® with ABS and Slide-Out Base (No Tablet)

#5610A-RT8 Alpha MUTT® with ABS and Rugged Tablet (No Slide-Out Base)

#5610A Alpha MUTT® with ABS (No Tablet or Slide-Out Base)

Innovative Products of America® Incorporated 234 Tinker Street, Woodstock, NY 12498
888-786-7899 | tech247@ipatools.com | www.ipatools.com



Congratulations on your recent purchase of an Alpha MUTT® Service-Truck Model from Innovative Products of America®!

This binder provides information on the following Alpha MUTT® units:

- **#5610A Alpha MUTT® with ABS (No Tablet or Slide-Out Base)**
- **#5610A-RT8 Alpha MUTT® with ABS and Rugged Tablet (No Slide-Out Base)**
- **#5611A Alpha MUTT® with ABS and Slide-Out Base (No Rugged Tablet)**
- **#5611A-RT8 Alpha MUTT® with ABS, Rugged Tablet and Slide-Out Base**

For questions or support, call 888-786-7899 or email tech247@ipatools.com.



845-679-4500
www.ipatools.com
tech247@ipatools.com

FOREWORD

The Alpha MUTT® (Mobile Universal Trailer Tester) Service-Truck Model has been thoroughly engineered to provide the ultimate level of control and diagnostic troubleshooting capability when inspecting trailer lighting, air brake and ABS systems. Your tester has been delivered “turnkey” with all the hoses, cables, remote controls and tablet needed to begin testing. Be sure to read the entire set up and instruction manual to ensure that all the benefits this tester can bring to your shop are utilized.

This Operator’s Manual has been created by Innovative Products of America® (IPA®) to provide users with the necessary information to:

- Identify and understand the full capabilities of the tester.
- Recognize the safety precautions that should be adhered to during operation.
- Properly identify all parts, accessories and attachments included with the tester for maintenance, operation, repair and replacement.

IPA® truly wants you to be 100% satisfied with your purchase. The Alpha MUTT® includes a 3-Year Warranty and 24-Hour Repair or Replace Policy. Upon first receiving your tester, use the provided unpacking sheet with included accessories kit for reference to specific accessories and features based on your particular model. If you are missing any accessories, have questions or need assistance with any step of the process, please call Tech Support at 888-786-7899 or email tech247@ipatools.com.

IPA® is also interested in hearing any suggestions you may have that could increase the productivity and functionality of the Alpha MUTT®. If there is a feature you wish it had, please send us your feedback and it may be included in the next update.

From all of us at IPA®, we thank you for your purchase and wish you and your family the very best of everything.

Ian Vinci,
President
Innovative Products of America®

TABLE OF CONTENTS

PART 1: INTRODUCTION AND SET-UP

	Pg.
1.1 Introduction	1-1
1.2 Important Safety Information	1-2
1.3 Battery Gases, Tester Preparation and Tester/Charger Location	1-2
1.4 General Charger Use	1-3
1.5 Registering Your Tester's Warranty	1-4
1.6 Tester Identification	1-5
Tester Serial Number	
Firmware Version Number	
Software Version Number	
1.7 Included Accessories	1-6
Optional Accessories	
1.8 Control Panels	1-8
Control Panel	
Right-Side Panel	
Lower Panel	
1.9 Battery/Power Supply Requirements	1-14
1.10 Auto Shutdown Feature	1-14
1.11 Connecting Shop Air	1-14
1.12 Truck-Box Installation	1-15
Installing a #5611A Series Unit	
Installing a #5610A Series Unit	
Installing 12V DC/Battery Connection	
1.13 Bluetooth®	1-18
Installing the Bluetooth® Communication Module	
Direct Connection	
Using an Extension Cable	
Bluetooth® Do's and Don'ts	
Bluetooth® Module FCC Regulations	
1.14 Remote Control	1-20
How to Program the 12-Button Remote	
How to Use the 12-Button Remote	
1.15 Tablet	1-20
Rugged Tablet Buttons	
Tablet Pen	
Power Saving	
Bluetooth® Connection	
How to Charge the Tugged Tablet with the AC Plug	
How to Charge the Rugged Tablet While Mounted in the Storage Drawer	
How to Check for Software Updates	
Email to Tablet	
Computer to Tablet	
Direct to Tablet	
1.16 Updating Firmware	1-22
Updating the System Firmware	
Updating the ABS PLC Firmware	
1.17 Maintenance and Storage	1-23
1.18 Frequently Asked Questions	1-23
1.19 Common System Checks	1-24
1.20 Common Troubleshooting Solutions	1-25
1.21 Instructions for In- and Out-of-Warranty Repairs	1-26

PART 2: ELECTRICAL, LIGHTING AND AIR BRAKE TESTING

2.1	Electrical/Lighting Testing	2-1
	Pretest Checklist	
	Tester Placement	
	Maintain Connectors	
	Cable Testing Procedure	
2.2	Selecting a Circuit	2-2
	Autocycle Mode	
2.3	Ground Integrity Test	2-4
	Chassis and Pin Grounds	
	Establishing a Chassis Ground	
2.4	Fault Indication	2-5
	Open Circuit	
	Crossed Circuit	
	Short/Overloaded Circuit	
2.5	Activating Hazard Lights	2-6
2.6	All Circuits On (Override) Mode	2-7
2.7	Air Brake Testing Set-Up	2-8
2.8	Actuating Air Brakes	2-9
2.9	Leakdown Testing	2-11
	Manual Leakdown Testing	
	Automatic Leakdown Testing	
	Changing Automatic Leakdown Test Parameters	

PART 3: ABS TESTING

3.1	Accessing ABS Codes	3-1
	ABS Explained	
3.2	Manual Controls	3-2
	Accessing Active Faults	
	Accessing Stored Faults	
	Clear All Codes	
3.3	Tablet Controls	3-4
3.4	Failure Mode Identifier (FMI) Assignments	3-5
3.5	SAE J1587 Mid 137 Sid List	3-6

PART 4: USING THE ALPHA MUTT® APP

4.1	Alpha MUTT® Application Setup	4-1
	Accounts	
	Company Information	
	Testing Defaults	
4.2	Menu Bar Screens	4-2
4.3	Diagnostic Controls	4-3
4.4	Electrical Inspections	4-4
	Pass Result	
	Fail Result	
4.5	DOT/PM Inspections	4-7
	Truck Inspection Controls	
	Trailer Inspection Controls	
4.6	Saved Reports	4-10
4.7	Inspection Creation Tab	4-11
4.8	Sample Reports	4-12

PART 5: TECHNICAL INFORMATION

5.1	Exploded Views	5-2
	Service-Truck Model Body Exploded View	
	Service-Truck Model Face Exploded View	
	Service-Truck Model Side Exploded View	
	Service-Truck Model Storage Drawer Exploded View	
	Service-Truck Model Door Exploded View	
	Service-Truck Model Slide-Out Tray Exploded View	
5.2	Typical Trailer Wiring	5-14
5.3	Complete Specifications	5-15
	#5610A Alpha MUTT® (2 nd Gen) with ABS Service-Truck Model	
	#5610A-RT8 Alpha MUTT® (2 nd Gen) with ABS and Rugged Tablet Service-Truck Model	
	#5611A Alpha MUTT® (2 nd Gen) with ABS and Slide-Out Base Service-Truck Model	
	#5611A-RT8 Alpha MUTT® (2 nd Gen) with ABS, Rugged Tablet and Slide-Out Base Service-Truck Model	
	#5700-TABRT-AS Military-Grade, Rugged Tablet	



PART 1: INTRODUCTION AND SET-UP

PART 1: INTRODUCTION AND SET-UP

1.1 Introduction

The Alpha MUTT® (2nd Gen) with ABS is an all-in-one, mobile, advanced diagnostic tester and inspection system for both vehicles and trailers. The Alpha MUTT® Series is IPA®'s premier trailer tester product line and is equipped to test lights, air brakes and ABS. These products are designed to withstand the rigors of everyday service.

While there are various models of the Alpha MUTT® available with different included accessories, all products that feature the name Alpha are Bluetooth® and RF equipped and can be operated by both tablet and RF remote control. The Alpha MUTT® is microprocessor controlled and features state-of-the-art current sensing, computer-controlled circuit protection, live circuit monitoring with automatic pass/fail calculations, as well as digital voltage and amperage draw readout. The Alpha MUTT® will detect poor grounds, open circuits, crossed circuits, short circuits, and also features Pulsar® mode which aides in troubleshooting intermittent and dead shorts. The ABS diagnostics can be utilized to read and clear codes and display troubleshooting information on a trailer via the 7-way connector. Those readings are displayed on the face panel as well as through the tablet app.

This manual covers the entire Alpha MUTT® series technology. Please consult your specific model for your exact list of included options. This product is backed by a 3-year warranty with 24-hour repair or replace service. Should you run into any issues, please contact IPA® directly at 888-786-7899 or email tech247@ipatools.com.

Testing Functions

- Electrical Testing (12/24 Volt Operation)
 - Automatic cross, open, overload, short and ground fault detection
 - Chases down short circuits with Pulsar® Mode
 - Cable testing
 - Ground failure detection: differentiates between wire and chassis ground
 - Detailed inspection reports generated from auto-test report function in under 60 seconds
- Air Brake Testing
 - Real-time, repetitive brake activation to find developing problems and verify leaking servo cans
 - Analog leak-down tests in service and emergency lines
- ABS Testing
 - Reads and clear codes
 - Displays diagnostic troubleshooting information
 - Accesses ECU data: manufacturer, make, model, etc.

1.2 Important Safety Information

It is important to read, understand and follow all safety messages and instructions printed in this manual and on the equipment before operating. If safety information is not heeded, serious injury or death to the operator or bystanders may occur.

Danger

Indicates a hazardous situation, if not avoided, will result in death or serious injury. The possible hazards are shown in the adjoining symbols or explained in the text.

Warning

Indicates a hazardous situation, if not avoided, could result in death or serious injury. The possible hazards are shown in the adjoining symbols or explained in the text.

Caution

Indicates a hazardous situation, if not avoided, may result in minor or major injury. The possible hazards are shown in the adjoining symbols or explained in the text.

The following safety alert symbols are used in this manual.



Symbol 1: Potential burn hazard. Sparks from electrical shorts can ignite flammable liquids such as fuel or oil. Heat from electrical overloads can cause fire hazards.

Symbol 2: Potential electrical hazard. Batteries have enough electrical energy potential to ignite flammable liquids such as fuel or oil. Wire overloads can cause electrical failures. Shock hazard exists.

Symbol 3: Potential explosive air hazard. Pneumatic pressures used with this equipment can cause explosive failures on damaged equipment.

Symbol 4: Potential eye hazard. Wear OSHA approved safety glasses. Battery acid and high air pressures create hazardous situations for eyes.

Symbol 5: Potential chemical burn hazard. Wear protective gloves. Battery acid is corrosive and can cause skin damage.

Symbol 6: Potential electrical hazard. Electrical energy can cause heat and burn hazards.

Symbol 7: Potential fire hazard. Use caution with flammable liquids such as fuel and oil. Electrical shorts can ignite flammable liquids and wiring.

Symbol 8: Important information is stated.

1.3 Battery Gases, Tester Preparation and Tester/Charger Location

Risk of Explosion

- Gases produced by a battery are highly explosive. Battery explosions can cause injury.
- Wear safety goggles and protective clothing, both users and bystanders.
- Use in an area having at least four air changes per hour.
- Read, understand and follow all instructions for charger, battery, vehicle and any equipment used near battery and charger.



- Do not smoke, strike a match, place metal tools on battery or cause a spark in the vicinity of the battery. When removing battery cables, remove the ground cable first.
- Clean terminals before charging battery. Keep corrosive particles from eyes, nose and mouth. Use baking soda and water to neutralize acid and help eliminate airborne corrosion.
- Never allow clamps on charger cables to touch each other.
- Do not expose tester or charger to rain, snow or wet conditions.
- Do not allow battery gases or acid to contact MUTT[®] cabinet. Do not place charger directly above or below battery.
- Fill battery to level specified by battery manufacturer using distilled water.
- Do not remove cell caps while charging per manufacturer instructions.
- Make sure tester cable clamps make tight connections.

1.4 General Charger Use

Risk of Electric Shock and Fire



- Before connecting charger cable to tester, make sure controls are set to OFF.
- Do not remove or bypass the grounding pin.
- Do not operate charger with damaged cord or plug. Replace immediately if damage occurs.
- Position power cord and charger cables away from the hood, doors and hot or moving engine parts where they could be damaged.
- Unplug power cord by grasping and pulling on the plug, rather than the cord, when disconnecting charger from outlet.
- Charger power cord uses an equipment-grounding conductor and a grounding plug. Plug only into a 120V AC outlet that is correctly installed and grounded in accordance with all ordinances and local codes.
- Unplug power cord from outlet before cleaning or maintaining tester and charger. Turning off controls does not reduce the risk of electric shock.
- Do not operate charger after a sharp impact, drop or any other damage. Do not disassemble.
- Use only recommended attachments.
- Do not charge a frozen battery. Do not overcharge a battery.
- Use charger only on lead-acid automotive batteries. Do not use charger to charge dry-cell batteries.
- Electric shock or fire can cause injury.

Risk of Entanglement

- Keep yourself, clothing and battery charger leads clear of moving parts such as fan blades, pulleys, doors and hood. Moving parts can cause injury.

Risk of Burns

- Batteries can produce a short circuit current that is high enough to weld jewelry such as rings, bracelets and watches. You must remove them before working near batteries.
- Short circuits can cause injury.

1.5 Registering Your Tester's Warranty

Innovative Products of America® (IPA®) has established a Limited Three-Year Warranty Policy for the Alpha MUTT® Series, not including any wearable parts, i.e., batteries (30-day warranty), battery clips, etc.

Three-Year Limited Warranty/Return or Replace Policy: The product is covered for three years from the date of original user purchase under the stipulations of the Standard Warranty.

The product is warranted to be free from defects in workmanship or material. If there is a defect, IPA® will repair or replace the product within 24 working hours after it is received at the IPA® repair service center. If the product has been tampered with or altered in any way, the warranty is void and all claims against the product will not be honored. The Warranty Repair/Return procedures require that proof of purchase must be established (either by warranty card or purchase receipt/invoice) and the manufacturer makes every attempt to return ship the product within three business days from the receipt of the returned product, freight prepaid. If it has been determined that the tool has been damaged due to misuse, IPA® will repair the unit at a cost we deem reasonable, and these charges will be the responsibility of the user. We genuinely want you to be happy with our products. If you have any questions, call us toll-free at 888-786-7899.

There are three options for registering your tester for warranty:

- Complete the included warranty card found in the front pocket of this binder and mail it to:

Innovative Products of America
234 Tinker Street
Woodstock, NY 12498

OR

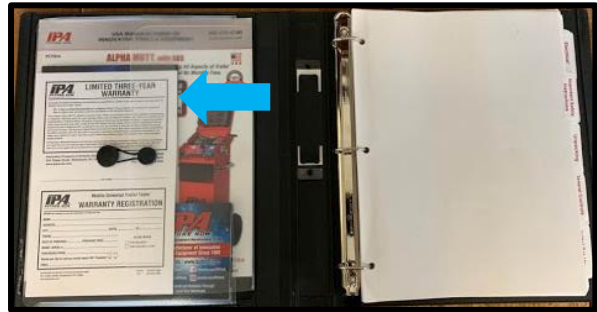

- Complete the online warranty registration at www.ipatools.com/warranty-returns/.

A screenshot of the online warranty registration form on the IPA website. The form includes fields for product line selection, company information (First Name, Last Name, Company, Street Address, City, State, Zip), contact information (Email Address, Phone), purchase details (Purchase Price, Model Serial, Purchase Date), and a checkbox for email preferences. A red 'SUBMIT' button is at the bottom.

OR

- Complete your registration on the Alpha MUTT® App under the SETTINGS section. (Currently unavailable)

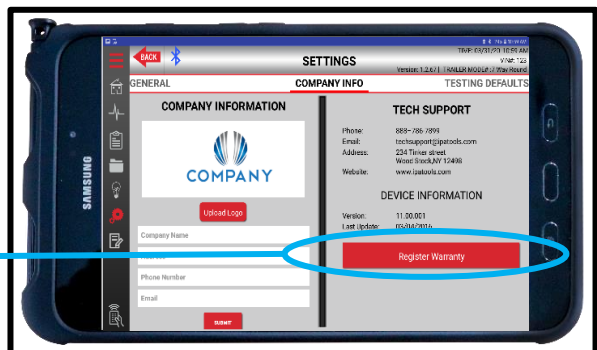

1.6 Tester Identification

Tester Serial Number

Located on the side of the tester.



Firmware Version Number

Displays on the Upper LCD Menu Screen when the tester is powered on.



Software Version Number

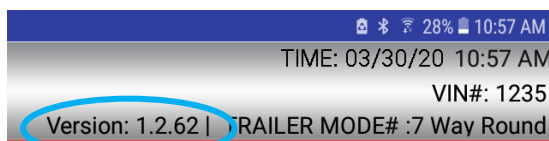

Located on the top right corner of any screen while in the Alpha MUTT® App.



1.7 Included Accessories

Image	Part #	Description	Included In
	#MUT2-RM12	2 nd GEN 12-Button Remote w/ Lanyard	All Models
	#5700-TABRT	Rugged Tablet	#5610A-RT8 #5611A-RT8
	#5700-MNTRT-AS	Mount for Rugged Tablet	#5610A-RT8 #5611A-RT8
	#5700-TABCHRT	Rugged Tablet Charger	#5610A-RT8 #5611A-RT8
	#5700-BT-AS3	Bluetooth® Antenna	#5610A-RT8 #5611A-RT8
	#CBL-OB2EXT	5' Bluetooth® Antenna Extension Cable	#5610A-RT8 #5611A-RT8
	#7900K-1-12AS	20' 7-Way Cable	All Models
	#5600-20RED-AS2 #5600-20BLUE-AS2	20' Gladhands with Handles	All Models
	#5600-PWRCBL-AS	Power Cable	All Models
X	#5600-SLDBASE-AS	Sliding-Base Service Tray	#5611A #5611A-RT8

Optional Accessories

Image	Part #	Description	Includes	Upgradable On
	#7900K-1-50-AS	50' 7-Way Cable	X	All Models
	#5705-HS50	50' Gladhands with Handles	X	All Models
	#MUT2-RT8	8" Rugged Tablet with Bluetooth® Kit and Standard Software License	Rugged Tablet, Docking Station, Hardware, Bluetooth® Module, 12" Bluetooth® Extension Cable, IPA® Diagnostic Software Suite	#5610A #5611A
	X	Sliding-Base Service Tray Update	Sliding-Base Service Tray, Hardware, Installation Instructions	#5610A #5610A-RT8

1.8 Control Panels

Mechanical Functions

The Alpha MUTT® has two dual-line, 32-character, all-environment digital screens, each with their own control knob. These screens are backlit for easy viewing at night, are sunlight-readable for daytime, and are wide-angle viewable.

1. The UPPER LCD SCREEN is designated for Air Pressure Testing. The Control Knob to the right of the screen can be used to access air brake leakdown test settings and view results on the LCD screen.
2. The LOWER LCD SCREEN is designated for Voltage, Current, ABS Diagnostics and Settings Menu. The Control Knob below it can be used to activate all electrical test modes, ABS diagnostics, and circuits to be diagnosed, as well as cycling through submenus when using the ABS App (See App Section for more details).

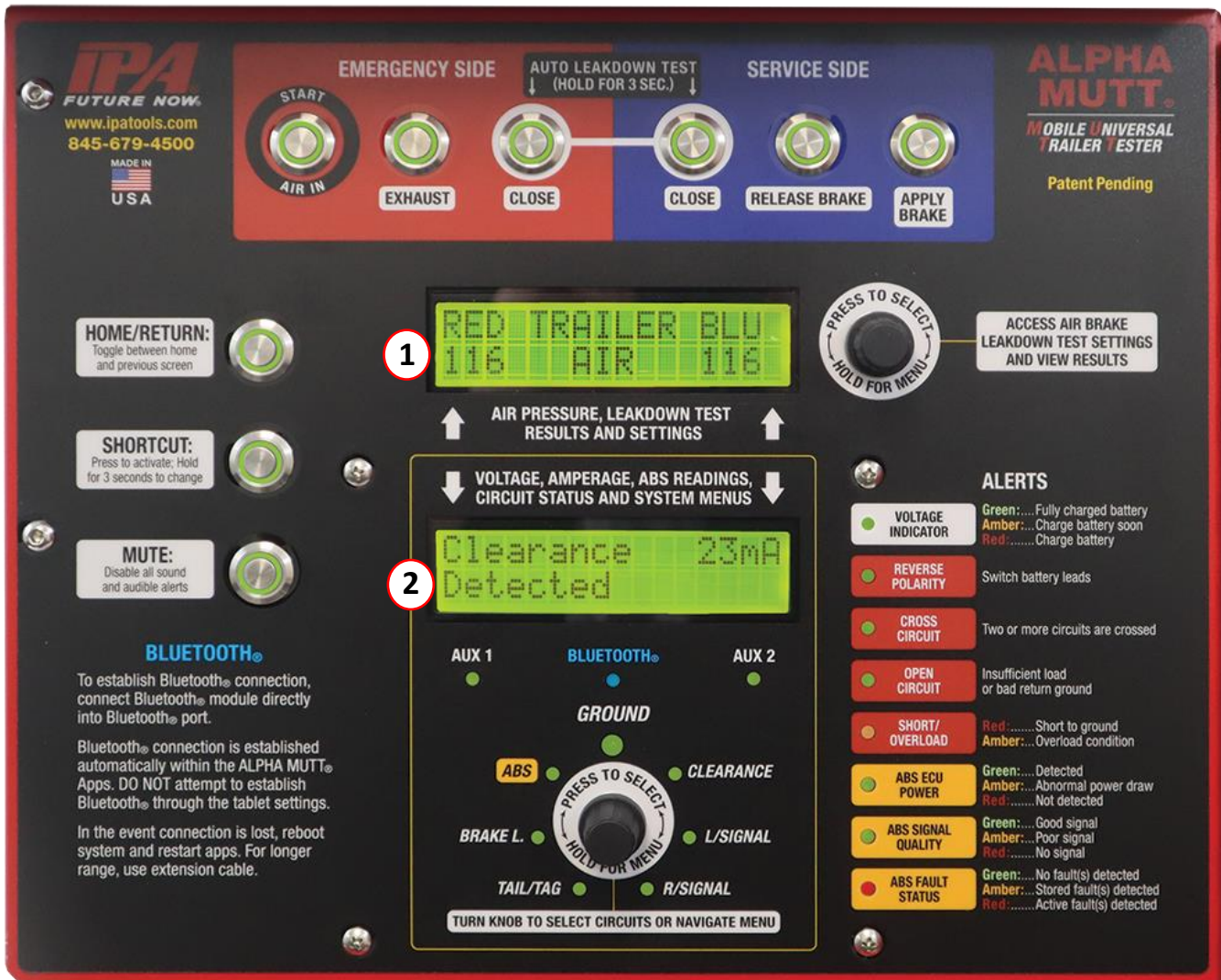

Control Panel

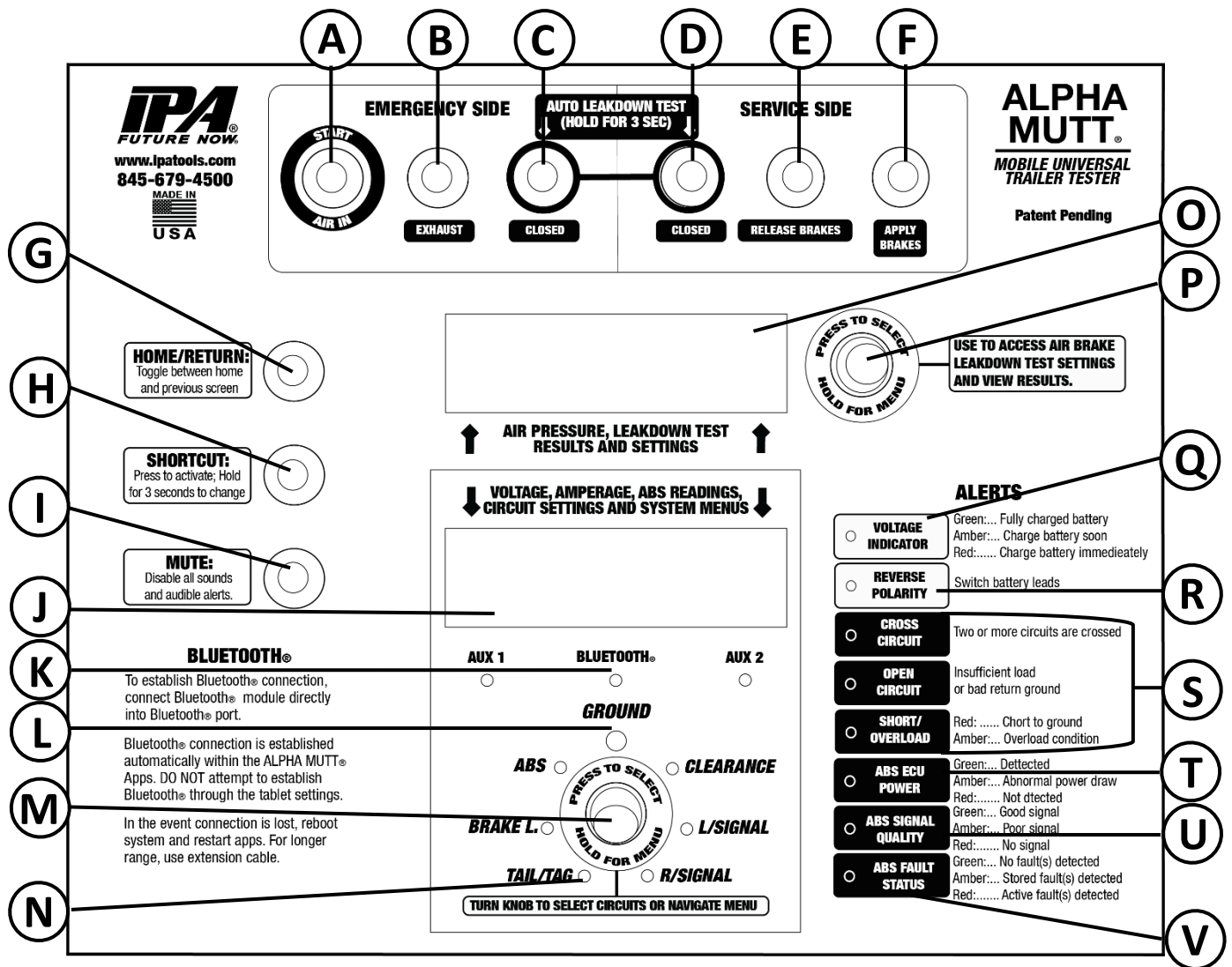

A. Start/Air In Button

Initiates Emergency-Side air and enables additional air operation functionality. PSI readings will not display until this button is pressed.

B. Emergency-Side Exhaust Button

Exhausts all air pressure in both the Emergency and Service sides.

C. Emergency-Side Closed Button

Closes Emergency-Side air. Can be used to initiate Auto Leakdown test when pressed simultaneously with the Service-Side Closed button.

D. Service-Side Closed Button

Closes Service-Side air. Can be used to initiate Auto Leakdown test when pressed with Emergency-Side Closed button.

E. Service-Side Release Brakes Button

Exhausts air and releases brakes.

F. Service-Side Apply Brakes Button

Initiates Service-Side air and applies brakes.

G. Home/Return Button

Toggles displays between reading voltage/current/amperage/air pressure and their last viewed menus or function screen.

H. Custom Button

Activates custom shortcut. Shortcuts can be set by holding button for three seconds.

I. Mute Button

Mute all alerts.

J. Lower LCD Screen

Shows voltage, amperage, ABS readings, circuit settings and system menus.

K. Bluetooth® Paired Indicator

Steady blue light indicates paired device.

L. Ground Integrity Indicator

Solid green LED indicates good ground. Blinking red LED indicates a bad/poor ground. Ground integrity is automatically verified when power is turned on.

M. Lower Control Knob

Used to select trailer circuits or to navigate system menus for Lower LCD screen.

N. Circuit Indicators

The small green LEDs illuminate or blink in testing phase.

O. Upper LCD Screen

Shows air pressure, leakdown test results and settings for brake testing.

P. Upper Control Knob

Used to access air brake leakdown test settings and view results on Upper LCD screen.

Q. Voltage Indicator

Green LCD indicates fully charged battery. Amber LED indicates battery will need charge soon. Red LED indicates battery needs charge immediately.

R. Reverse Polarity Indicator

Indicates when battery leads need to be switched due to reversed polarity.

S. Trouble Warning Indicators

Flashing red LEDs indicate problems that may exist in a selected circuit. This includes the Cross Circuits indicator, Open Circuit indicator and Overload indicator.

T. ABS ECU Power Indicator

Indicates health status of ECU circuit by analyzing electronic signature of ABS ECU.

U. ABS Signal Quality Indicator

Indicates the communication status of ABS computer through proprietary technology. LED colors display the specific status and should be referenced in relationship to the ABS ECU Power and ABS Fault Status indicators.

V. ABS Fault Status Indicator

Indicates if any types of ABS faults are present on the trailer.

Right-Side Panel

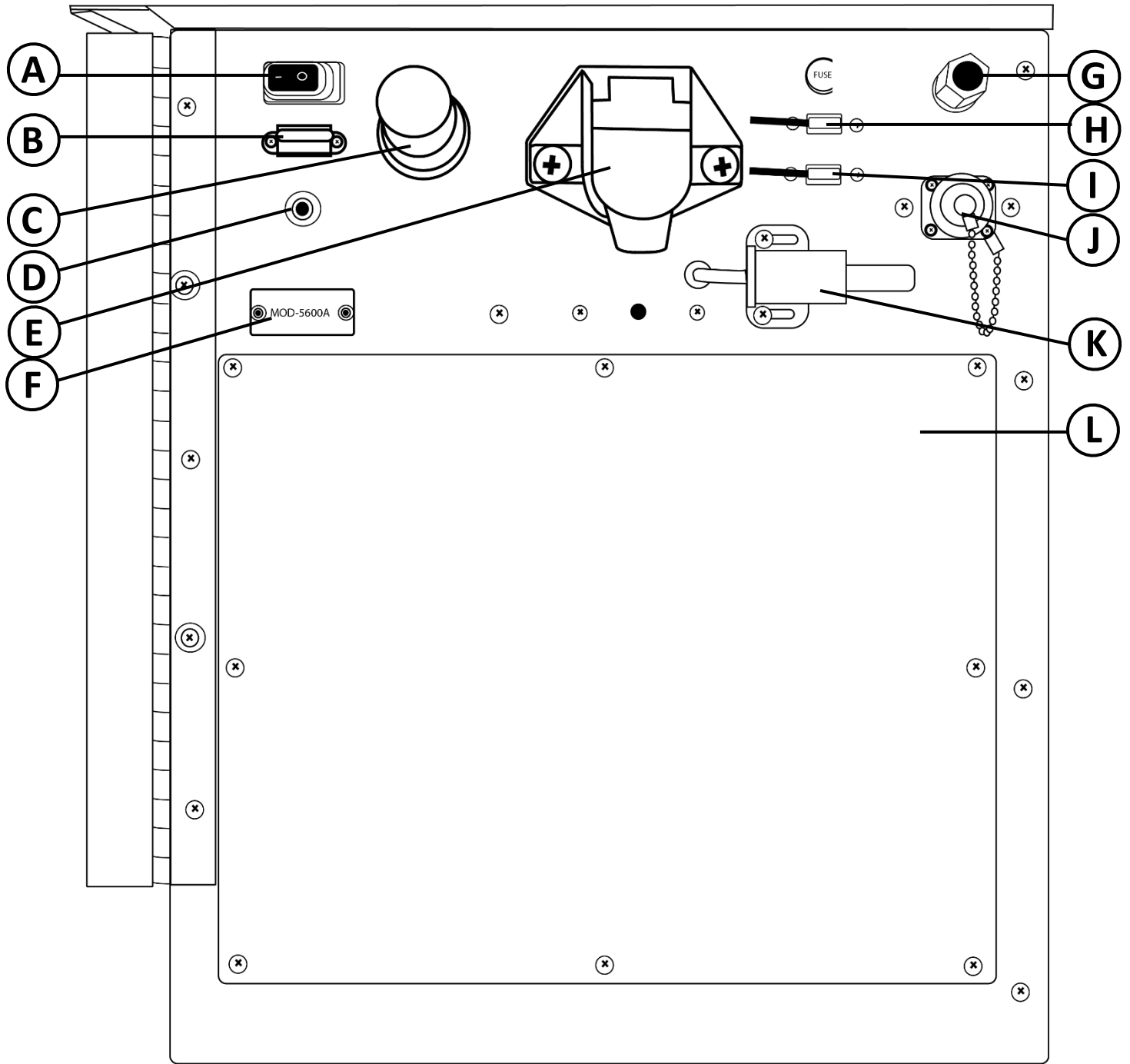

A. Main System Power Switch

Powers on or shuts down the Alpha MUTT®.

B. 30 Amp Fuse Socket

Overload protection for unit.

C. Air-Regulator Knob

For setting system pressure up to 120 psi.

D. Chassis Ground Outlet

Bypasses cable ground and establishes chassis ground from tester directly to trailer chassis.

E. Cable/Truck Test Input

For running cable tests and connecting directly to tractor.

F. Serial Tag

Product part number and serial number.

G. Shop Air Input

A bulk-head air input that is used to connect an air compressor to the Alpha MUTT® for testing air brakes on a trailer.

H. Main Circuit Board Update Port

For updating system firmware, including light and air brake testing controls and menus.

I. ABS Circuit Board Update Port

For updating firmware of ABS diagnostic board.

J. 20 Amp Independent Power Input

For connecting external 12V DC 20-amp max. power supply, such as external battery, or hardwiring to vehicle with charging system. Not recommended to connect to 12-volt wall plug in power supplies while short circuit testing.

K. Bluetooth® Antenna

For Bluetooth® connectivity.

L. Access Panel

For accessing and maintenance on internal parts.

Lower Panel

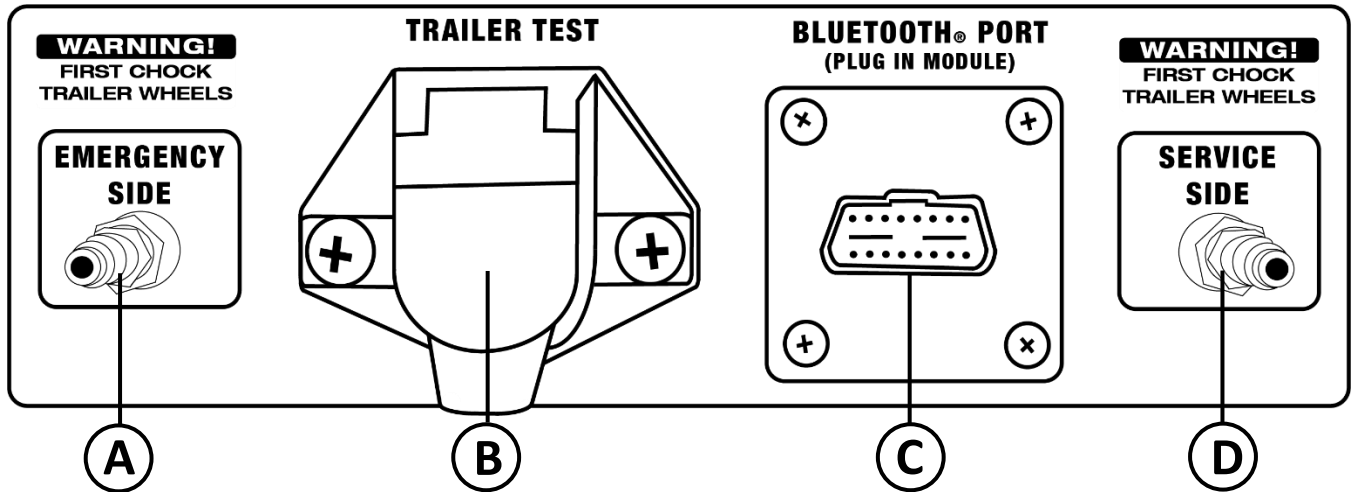

A. Emergency-Side Air Out

For connecting the Emergency-Side Gladhand hose (red).

B. 7-Way Round Pin Cable Out to Trailer

For connecting 7-way round pin trailer to the Alpha MUTT[®] to test electrical circuits. Should also be used during cable tests (See **Part 8: Electrical/Lighting Testing**).

C. Bluetooth[®] Communication Port

For connecting the included Bluetooth[®] module.

D. Service-Side Air Out

For connecting the Service-Side Gladhand hose (blue).

1.9 Battery/Power Supply Requirements

The Alpha MUTT[®] is a 12/24V DC device. Attempting to power the MUTT[®] with anything other than a 12- or 24-volt DC power source will destroy the internal circuitry and void the warranty.

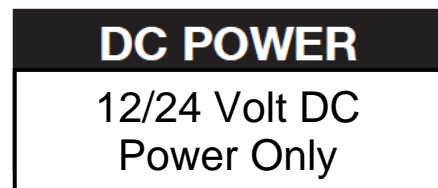

- The Alpha MUTT[®] Service-Truck Model requires an external DC power source to function. A Group 31 or similar battery is recommended.
- The Service-Truck Model does NOT have a built-in charger.
- The battery in the service truck must be maintained at a voltage between 12- and 14.5-volts DC. Typically, batteries wired in parallel with the vehicle's own battery system will suffice.
- If running a dedicated power wire from a vehicle's main batteries, a 10-gauge wire is recommended for runs up to 40' and an 8-gauge wire is recommended for runs longer than 40'.
- All wiring must be able to carry a sustained current of 21 amps at 12V DC.
- An external (2 pin) DC power connector is provided with the tester. That power connector terminates to a 2 prong SAE connector. A mating SAE connector on a 3' cable with bare ends is also provided. This cable can be used to make the connection to the vehicle's battery or dedicated wires.
- Follow standard battery wiring procedures. RED indicates Positive and Black indicates Negative. When a cable has two black leads, if one lead has a white stripe, that lead is Positive.
- Prior to making connections, verify proper voltage orientation from the vehicle using standard Automotive Style Volt Meters.
- The DC power connections require routine preventive maintenance to avoid downtime. The two-prong connector should be disconnected and inspected once per month. Pins should be checked for corrosion on both the cable and tester sides. If corrosion is present, clean connectors using IPA[®]'s patented CLR156 Terminal Cleaners. Then clean the connections using IPA[®] 8035A DeoxIT[®] contact cleaner. Replace connector if needed. Check the replacement parts section of this manual for all related components.

1.10 Auto Shutdown Feature

If left inactive for a period of 20 minutes, the Alpha MUTT[®] will enter a Sleep mode and power down.

- A sound is emitted every 20 seconds during Sleep mode.
- Activation of either control knob will cancel Sleep mode.

1.11 Connecting Shop Air

1. Be sure to leave an additional 18" of air-line length so the tester can be pulled out via the slide-out base without damaging the air input. A 3/8" OD coiled air hose extension is recommended.
2. Locate the 1/4" female NPT bulkhead fitting located near the 12V power input.
3. Install the male end of the air hose into the connector while firmly holding a wrench onto the hex bulkhead to prevent any internal components from becoming damaged.

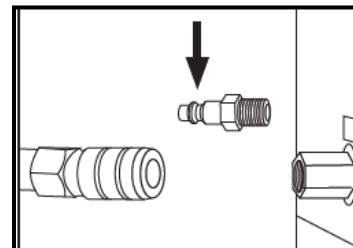

NOTE: It is always recommended to apply Teflon Tape to threads and then Pipe Dope over the Teflon prior to assembling NPT fittings.

WARNING: Listen for any air leaks where the shop air connects to the tester to avoid erroneous results.

1.12 Truck-Box Installation

The Alpha MUTT® (2nd Gen) with ABS Service-Truck Model is an all-in-one trailer tester that features lighting, air brake and ABS diagnostics built onto a platform with both the End User and Upfitter in mind. Each unit is easy to install, easy to operate, durable and weather protected, as well as easy to service.

#5610A models feature anti-vibration feet with a drill-through design for securing into service-truck boxes. #5611A models feature a removable slide-out base that includes the anti-vibration feet with drill-through design for securing into service-truck boxes. Each unit arrives with all the accessories and hardware needed for its individual installation.

Installing a #5610A Series Unit

1. Drill Mounting Holes into the Service-Truck Box

- a. Utilize the provided drill template, Option B. Notice the template has 4 predrill hole locations labeled B. Cut out or fold along the inner square template.
- b. Lay the template into the bottom of the service-truck box and slide it into the rear left-most position. Make sure the template lays flat – Use tape to ensure proper layout.
- c. Use the template holes to mark all 4 drill points.
- d. Drill all 4 holes using a 13/32” drill bit for the provided stainless steel mounting bolts.

2. Bolt the Unit to the Service-Truck Box

- a. Move the #5610A into position so that the 4 anti-vibration feet line up with the drilled holes in the box.
- b. Using the supplied hardware, thread bolts with washers through bottom of the box into each foot. Loosely thread each bolt until the final position is confirmed. Apply final torque to all four bolts.

3. Install 12V DC/Battery Connection

NOTE: #5610A is designed to have a constant 12V DC power supply from the vehicle's battery system. The tester already incorporates onboard fuse protection, so no additional fusing is required.

- a. Locate the supplied 2-prong connector and install the wire harness to identified + and - connections. It is recommended to apply some dielectric grease to both the assembled terminals and mating plug sides prior to use.
- b. Plug the connector into the 2-pole socket located on the back, right side of the tester.
- c. To power on the tester, press the power switch to the ON position.

4. Install Shop Air

- a. Locate the ¼” female NPT bulkhead fitting located near the 12V power input.
- b. Install the male end of the air hose into the connector while firmly holding a wrench onto the hex bulkhead to prevent any internal components from becoming damaged.
 - i. It is always recommended to apply Teflon Tape to threads and then Pipe Dope over the Teflon prior to assembling NPT fittings.

5. Assembly is Complete!

Installing a #5611A Series Unit

1. Drill Mounting Holes into the Service-Truck Box

- a. Utilize the provided drill template, Option A. Notice the template has 4 predrill hole locations labeled A.
- b. Lay the template into the bottom of the service-truck box and slide it into the rear left-most position. Make sure the template lays flat – Use tape to ensure proper layout.
- c. Use the template holes to mark all four drill points.
- d. Drill all four holes using a 11/32” drill bit for the stainless steel mounting bolts.

2. Place the Slide-Out Base into the Service-Truck Box

NOTE: This operation can be performed in two ways. The Primary method is to leave the tester attached to the base, utilizing the extended position. The Alternate method involves completely removing the base from the tester by pulling up on the two blue handles and sliding the tester out completely. HOWEVER, this is NOT the recommended method, as reinstalling the tester onto the base must be done with care to prevent damage to the base components.

- a. Place the tester on level ground then pull up on both blue levers and extend the tester to the first locked position. This operation is best completed with two people.
- b. Pick up the tester and carefully place the back side of the slide-out base into the bottom of the service-truck box. Be careful not to damage the front components, such as the 7-way socket during this process. (See Fig. 1A – Fig. 3)

3. Bolt the Slide-Out Base to the Service-Truck Box

- a. Move the assembly into position so that the four anti-vibration feet line up with the drilled holes in the box.
- b. Using the supplied hardware, thread bolts with washers through bottom of the box into each foot. Loosely thread each bolt until the final position is confirmed. Apply final torque to all four bolts.

4. Install 12V DC/Battery Connection

NOTE: #5611A is designed to have a constant 12V DC power supply from the vehicle's battery system. The tester already incorporates onboard fuse protection, so no additional fusing is required.

- a. Be sure to leave an additional 18” of harness length so the tester can be pulled out via the slide-out base without damaging the 12V input harness.
- b. Locate the supplied two-prong connector and install the wire harness to identified + and - connections. It is recommended to apply some dielectric grease to both the assembled terminals and mating plug sides prior to use.
- c. Plug the connector into the two-pole socket located on the back, right side of the tester.
- d. To power on the tester, press the power switch to the ON position.

5. Install Shop Air

- a. Be sure to leave an additional 18” of air line length so the tester can be pulled out via the slide-out base without damaging the air input. A 3/8” OD coiled air hose extension is recommended.
- b. Locate the 1/4” female NPT bulkhead fitting located near the 12V power input.
- c. Install the male end of the air hose into the connector while firmly holding a wrench onto the hex bulkhead to prevent any internal components from becoming damaged.
 - i. It is always recommended to apply Teflon Tape to threads and then Pipe Dope over the Teflon prior to assembling NPT fittings.

6. Assembly is Complete!

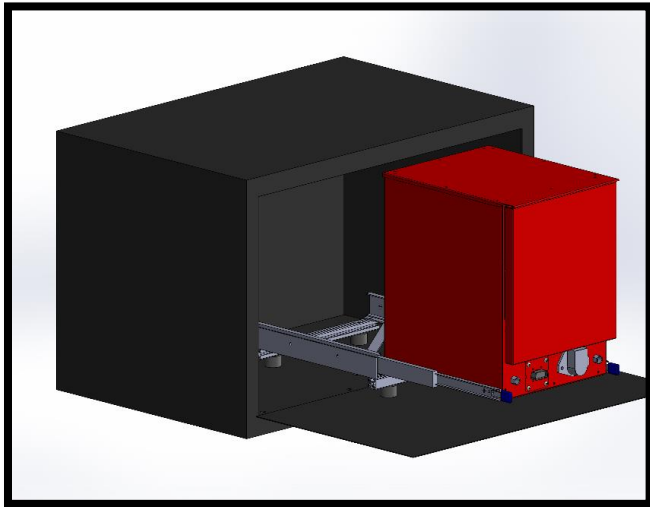

Fig. 4-3A

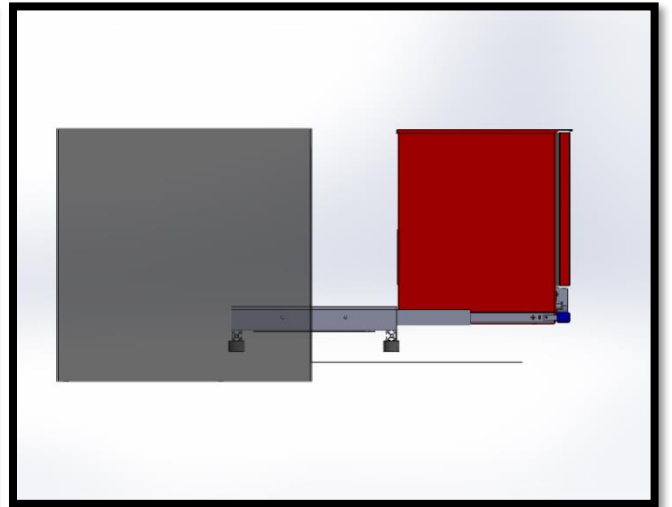

Fig. 4-3B

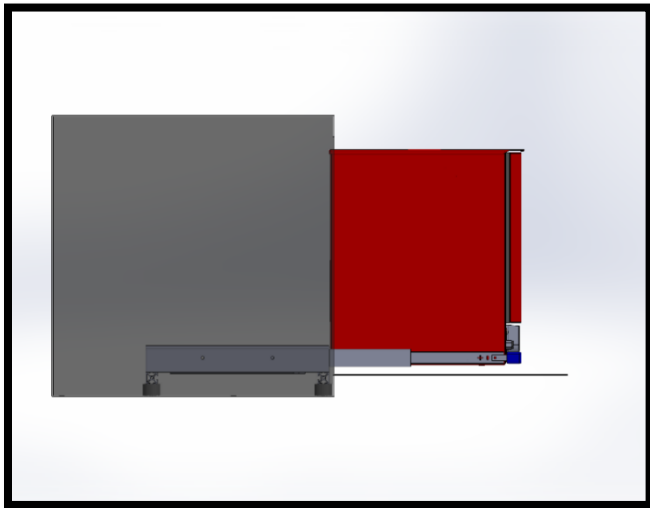

Fig. 4-3C

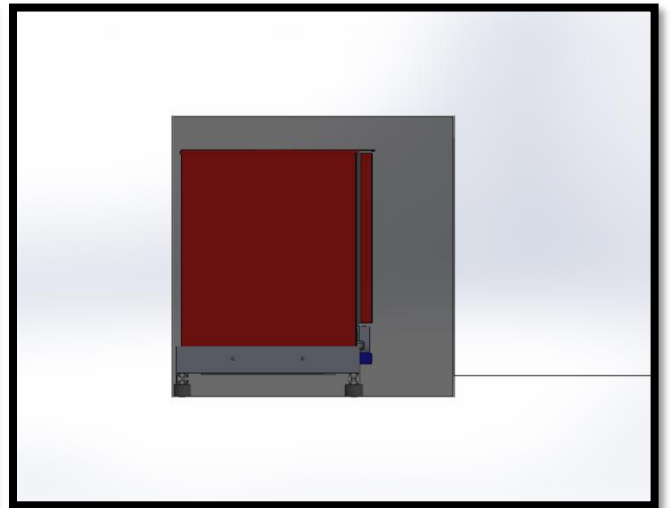

Fig. 4-3D

Installing 12V DC/Battery Connection

NOTE: The Alpha MUTT® is designed to have a constant 12V DC power supply from the vehicle's battery system. The tester already incorporates onboard fuse protection, so no additional fusing is required. This operation can be performed in two ways. The Primary method is to leave the tester attached to the base, utilizing the extended position. The Alternate method involves completely removing the base from the tester by pulling up on the two blue handles and sliding the tester out completely. HOWEVER, this is NOT the recommended method, as reinstalling the tester onto the base must be done with care to prevent damage to the base components.

1. Be sure to leave an additional 18" of harness length so the tester can be pulled out via the slide-out base without damaging the 12V input harness.
2. Locate the supplied 2-prong connector and install the wire harness to identified + and - connections. It is recommended to apply some dielectric grease to both the assembled terminals and mating plug sides prior to use.
3. Plug the connector into the 2-pole socket located on the back, right side of the tester. The door incorporates a key-lock position to prevent the connector from disconnecting. Push the connector in firmly to engage the lock.
4. To power on the tester, press the power switch to the ON position.

1.13 Bluetooth®

Installing the Bluetooth® Communication Module

The tablet controls the Alpha MUTT® through a Bluetooth® connection; 4.0 or newer BLE (Bluetooth® Low Energy) technology. This technology provides faster response times at longer distances. If the BLE connection is lost during operation, you can attempt to reestablish the connection by accessing the BLE Connection button in the Alpha MUTT® app. Otherwise, shut down the app and cycle power to the trailer tester.

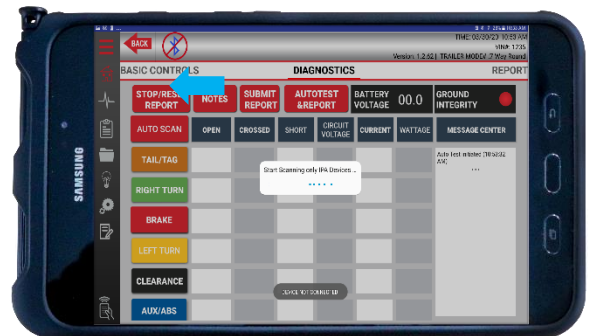

The Alpha MUTT® communicates with the Alpha MUTT® app via the Bluetooth® Communication Module (#5700-BT-AS3 located in the unit's drawer). The Bluetooth® Communication Module can be installed directly into the Bluetooth® Communication Port on the front of the tester, or you can use the 5' Bluetooth® Antenna Extension cable included with your unit (#CBL-OB2EXT).

Direct Connection

Plug the Bluetooth® Communication Module directly into the Bluetooth® Communication Port on the front of your unit. Make sure to insert the module securely, pushing firmly until it bottoms out in the port for best connectivity.

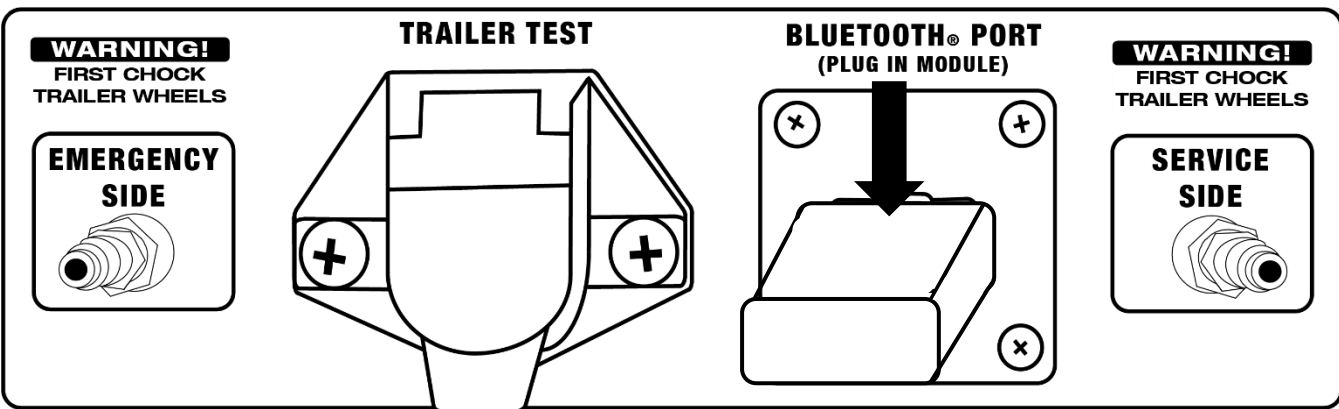

Using an Extension Cable

Plug the Bluetooth® Communication Module into the female end of the included extension cable. Plug the male end of the cable directly into the Bluetooth® Communication Port on the front of your unit. Make sure to insert the module and cable securely, pushing firmly until it bottoms out in the port for best connectivity.

Move the module and extension cable to a position that provides the best range to the tablet. Typically, the closer to large metal surfaces, the poorer the communicating.



WARNING: DO NOT GET WET. Water intrusion will damage the circuitry and damage the module.

Bluetooth® Dos and Don'ts

- The Bluetooth® connectivity should automatically establish when the app is initiated.
- Bluetooth® connectivity can be verified in the top bar of any screen on the app. If the Bluetooth® logo has a red cross on it, the app is not connected to the tester and Bluetooth® must be reestablished.
- Bluetooth® connectivity should be established within IPA® apps, not through the main settings of the tablet.
- To re-establish Bluetooth® connectivity, press the icon to start scanning for available devices.
- When establishing connection, avoid other Bluetooth enabled devices, such as phones, speakers, and other tablets.

Bluetooth® Module FCC Regulations

This equipment has been tested and found to comply with the limits for a Class B digital device, pursuant to part 15 of the FCC Rules. These limits are designed to provide reasonable protection against harmful interference in a residential installation. This equipment generates, uses and can radiate radio frequency energy, and if not installed and used in accordance with the instructions, may cause harmful interference to radio communications. However, there is no guarantee that interference will not occur in a particular installation.

If this equipment does cause harmful interference to radio or television reception, which can be determined by turning the equipment off and on, the user is encouraged to try to correct the interference by one or more of the following measures:

- Reorient or relocate the receiving antenna.
- Increase the separation between the equipment and receiver.
- Connect the equipment into an outlet on a circuit different from the one the receiver is connected to.
- Consult the dealer or an experienced radio/TV technician for help.

1.14 Remote Control

The included 2nd Gen 12-button remote control is preprogrammed to the Alpha MUTT[®] and should never lose its programming. If you suspect a remote has lost its programming, contact Technical Support at 888-786-7899 or email tech247@ipatools.com.

How to Program the 12-Button Remote

1. Press and hold the top center button while turning the Alpha MUTT[®]'s power ON.
2. Continue to hold the button for two seconds and then release.
3. The remote control is now programmed.

How to Use the 12-Button Remote

1. Circuit Selection

Pressing the buttons will select the corresponding circuit on the Alpha MUTT[®]. (Pressing and holding the ABS/AUX or Brake Light buttons will latch both circuits on.)

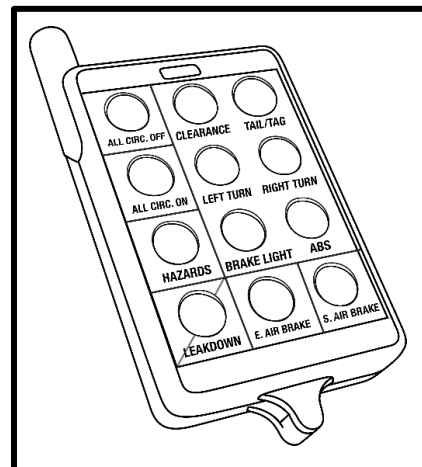

WARNING: Inclement weather, nearby power transformers and closely parked trailers may reduce the remote signal.

1.15 Tablet

The Alpha MUTT[®] can be equipped with an 8" military-grade, rugged tablet which provides leading-edge technology in performance, battery life, screen resolution and security integration. The tablets are available as field-upgrades for models that are purchased without one.

Rugged Tablet Buttons

The rugged tablet features several buttons which provide quick access to important features. These buttons include Power, Volume, Multi-View, Home and Back. You will find that using the Back button will be very helpful during normal operation of the Alpha MUTT[®] apps. To view all open apps or force close an app, press the Multi-View button.

Tablet Pen

The rugged tablet also includes an S Pen for easier note taking, signatures and controls. All functions can be performed with or without the pen.

Power Saving

You can extend battery life by limiting tablet performance. Access the tablet's screen brightness, timeout, and other battery saving options through the Settings app.

Bluetooth[®] Connection (BLE)

The rugged tablet controls the Alpha MUTT[®] through a Bluetooth[®] connection. See Section 1.13 for more information on Bluetooth[®].

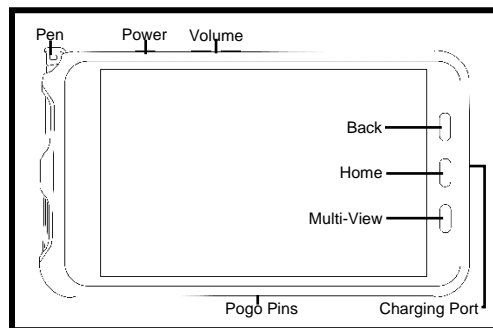

How to Charge the Rugged Tablet with the AC Plug

When a tablet is included, it is charged before shipping. The AC plug charging head and cable are stored in the accessories bag. Plug the smaller end of the cable into the charging port on the tablet and plug the larger USB end into the charging head. Plug the AC plug charging head into an electrical outlet to charge the tablet.

WARNING: Only use the provided AC plug charger with the tablet. Using another charger may cause damage or void any warranty.

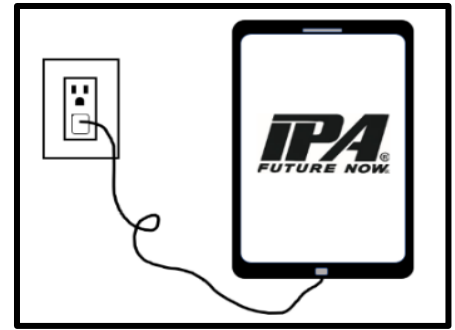

How to Charge the Rugged Tablet While Mounted in the Storage Drawer

The RT8 models come with a quick-connect, wireless docking station installed in the soft-close storage drawer of the Alpha MUTT®. Snap the rugged tablet into the case, bottom first, so that the Pogo pins touch. The tablet will automatically start charging once the connection is made.



How to Check for Software Updates

IPA® will periodically update the software for the Alpha MUTT® tablet to increase functionality. While IPA® makes every effort to send out testers with the most up-to-date version of software, it is good practice to check for updates before you begin using the tester. To access any Alpha MUTT® updates, please visit <http://support.ipatools.com> and register an account.

There are three options for downloading the IPA® Productivity Software Suite:

Email to Tablet: (Requires email account on tablet)

- Log in to <http://support.ipatools.com>.
- Click download for either the Alpha MUTT® App update or ABS App update as required.
- Once downloaded, email the app update file to the account set up on your tablet.
- Download the app update file from your email to your tablet.

Computer to Tablet:

- Log in to <http://support.ipatools.com>.
- Click download for either the Alpha MUTT® App update or ABS App update as required.
- Once downloaded, connect your tablet to your computer via the tablet's USB cable to upload the app update directly to your tablet.

Direct to Tablet:

- Log in to <http://support.ipatools.com>.
- Click download for either the Alpha MUTT® App update or ABS App update as required.

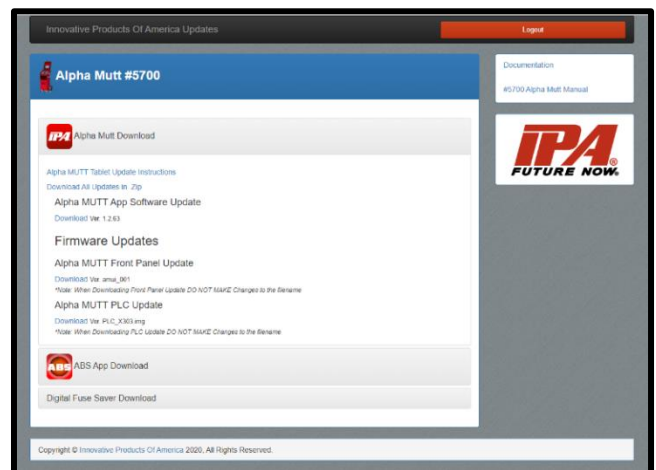

Once downloaded to the tablet, the app can be updated:

- Select the **My Files** app on tablet.
- Scroll down on the left side menu to **Downloads**.
- Click the recently downloaded file (it will end in .apk).
- Choose **Install** in the bottom right corner.

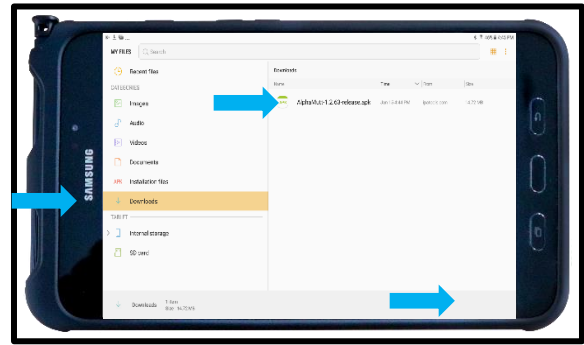

1.16 Updating Firmware

IPA® may periodically update the firmware for the Alpha MUTT® to increase functionality. While we try to always send out testers with the most up-to-date version of firmware, it is good practice to check for updates before you begin using the tester.

From a computer, visit <http://support.ipatools.com>. Create/login to your account with your email. If there are any updates available to the firmware, simply download them directly to your computer and then extract the raw files from the zip folder and save them to a USB flash drive.

NOTE: The USB must be 4 GB or less.

Updating the System Firmware

1. Turn the Alpha MUTT® on.
2. After the system fully boots, press and hold the Lower Control knob for 3 seconds to access the system settings.
3. Rotate the knob clockwise until you reach the UPDATE SYSTEM FIRMWARE menu option. Press the control knob and follow the instructions on the display.

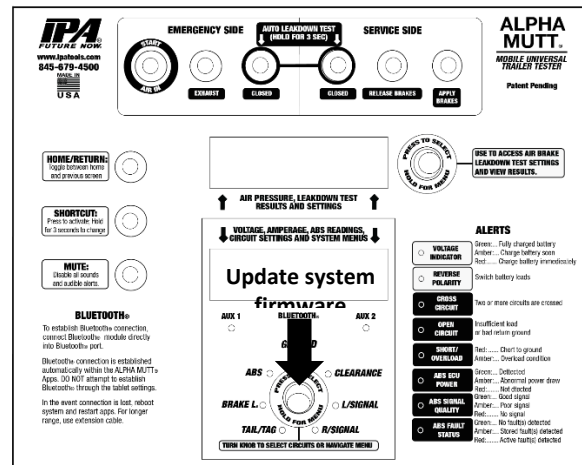

Updating the ABS PLC Firmware

1. With the tester off, insert the USB flash drive with the ABS PLC Firmware into the Lower USB port located on the side panel.
2. Turn the tester on. After the system fully boots press and hold the Lower Control knob for 3 seconds to access the system settings.
3. Rotate the knob clockwise until you reach the PLC FIRMWARE menu option. Press the control knob and allow the unit to read the newly installed firmware revision.

NOTE: For assistance or questions regarding updating the firmware on the Alpha MUTT® please contact Technical Support at 888-786-7899 or email tech247@ipatools.com.

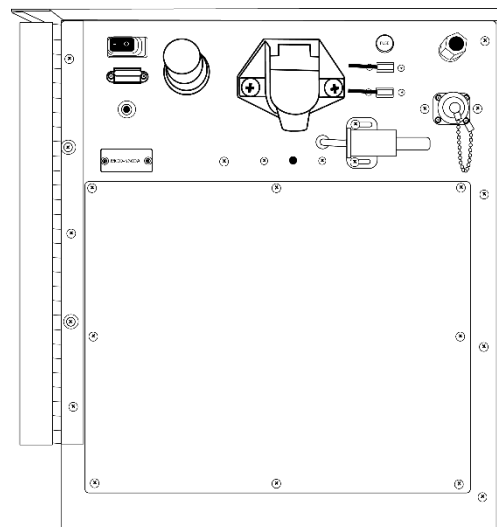

1.17 Maintenance and Storage

- Switch power to OFF, remove all power cables and disconnect battery before storing and cleaning.
- Wipe surfaces down with a well-wrung, soft, damp cloth.
- Diluted dishwashing liquid or similar substance can be used in the dampened cloth if necessary.
- Frequently clean and resize the 7-way pin connectors and add dielectric grease to the 7-way pin connector outlet. This will ensure a proper connection when using your Alpha MUTT®.
- Do not allow water to enter the control panel.
- Store in a cool, dry area when not in use and cover your Alpha MUTT® to prevent dust from accumulating.
- Do not store in direct sunlight.
- Do not store near magnetic field or damage to the microprocessor may occur.
- Make sure your air supply is run through a water separator and is filtered before attaching air supply to the tester.

1.18 Frequently Asked Questions

- Besides the tablet, is there any other form of removable storage?
 - The tablet offers a storage expansion in the form of a micro-SD card port (micro-SD card not included).
- What type of memory does the tester use?
 - The Alpha MUTT® does not house any internal memory for saving reports. All memory is stored on the Tablet. Tablets do feature expandable storage options. Call IPA® Tech Support for further information on how to expand memory.
- Does the Alpha MUTT® have the ability to transmit information through any type of wireless capabilities?
 - The Alpha MUTT® uses an RF signal of approximately 430 Mhz that can be used to control circuits. The tablet uses Bluetooth® 4.0 to connect to the tester to control it and run diagnostic reports. Wi-Fi is used on the tablet for connection to the internet to share reports.
- Can each capability be disabled?
 - The Wi-Fi can be turned off while Bluetooth® is being used. The tablet can enter airplane mode to turn off all wireless communication.
- Can all functions of the Alpha MUTT® be used without the tablet?
 - Virtually every function of the ALPHA MUTT® can be used without the tablet, except for the following: customized maintenance inspection templates, reporting/receipts, ABS diagrams, 1-button pass/fail result auto-scan, alternative wiring configurations, remote ammeter readout.
- What type of security does the tablet offer?
 - The tablet features Knox Security, which is almost exclusively approved and used by several US security and law enforcement agencies.

- How do I pair my Bluetooth® tablet to the Alpha MUTT®?
 - Open the Alpha MUTT® app and the tablet should automatically pair with the Alpha MUTT®. If the tester disconnects for some reason, tap the Bluetooth® icon on the top left of the Alpha MUTT® app screen to re-pair the tablet. (DO NOT attempt to pair the tester and tablet through the tablet's settings screen.)
- How do I troubleshoot poor connectivity problems?
 - NEVER assume a connection is a quality connection. Many ABS issues are the direct result of poor pin or sensor connections. These poor connections can be located directly at the ABS ECU on the trailer and typically can be found at the 7-way round nose box connection. If you suspect poor connectivity problems, verify the 7-way cable is securely inserted into the 7-way connection. Make sure the cable head is bottomed out in the connector. Always be certain to check the 7 pins in each plug are clean and spread to proper size before using.
- The ABS information is not being sent.
 - ABS information is sent via PLC (power line communication). PLC is delivered on a frequency over the DC power wire and a loss of communication can occur from mild corrosion or a faulty ground.
- The ABS computer can be heard powering up when the ABS circuit is selected, but no codes are retrieved. The ABS light is on, signaling there is an Active Fault, but the Alpha MUTT® detects no communication from the ABS ECU on the trailer.
 - This symptom can be the result of poor wire connection at the 7-way connection or the main power connector going into the trailer ECU. Remove the connections and clean them with the IPA® #CLR-90, #CLR-188 and #CLR-250 pin cleaners. Once cleaned, treat the electrical connection with IPA® Contact Cleaner and Shield. These tools can be found in the IPA® #8048 HD Fleet Technician's Electrical Terminal Maintenance Set.

1.19 Common System Checks

There are many safety and operational functions to test on a trailer. With the Alpha MUTT®, these tests can be performed without the truck or tractor, quickly, accurately and in most cases, with only one person. Below are a few common system checks that can be performed using the Alpha MUTT®.

- One-man leak and shake testing throughout the trailer.
- Pushrod travel measurements.
- Slacker adjustment reading specific to the manufacturer's specifications on brake chamber and proper operation notes.
- Even brake pressure activation.
- One-man, wheel-off-ground testing for brake strength and operation.

1.20 Common Troubleshooting Solutions

Symptom	Possible Cause	Solution
30-Amp fuse keeps blowing.	Shorted cig. socket or power connector.	Remove wires going to cig. socket. If fuse still blows, call Tech Support at 888-786-7899.
App won't connect to Bluetooth®.	Main Bluetooth® turned off on tablet.	Ensure Bluetooth® is turned on in the tablet settings.
	Tester not powered on.	Ensure the tester is turned on and displaying at least 12V.
	Bluetooth® antenna not installed properly.	Remove Bluetooth® antenna and reinstall, making sure to press firmly into Bluetooth® Communication Port.
	Out of range.	Stand closer to Tester during start up.
Open Circuit Warning.	Poor pin connections.	Spread and grease pins
	Trailer circuit is disconnected.	Check trailer wiring.
	Current draw from trailer is too low or nonexistent.	Make sure trailer lights are connected.
<p>Short/Overload Warning: System goes into overload or short circuit protection if more than 21 amps of current draw at 12V is detected for longer than 69 milliseconds.</p> <p>Short Is indicated by Red LED. Overload is indicated by Yellow.</p>	<p>Short circuit condition is detected if the overdraw > 50 amps in less than 69 milliseconds. Short is defined by positive power connected directly to ground.</p>	Remove cause of short and retest.
	<p>Overload is determined if overdraw > 21 amps but < 50 amps in 69 milliseconds. Overload is defined by more current being drawn than is allowed by circuit wiring sizes.</p>	

NOTE: For more troubleshooting help, please call 888-786-7899 or email tech247@ipatools.com.

1.21 Instructions for In- and Out-of-Warranty Repairs

If you experience any difficulty with your Alpha MUTT®, please call IPA® toll free at 888-786-7899 and speak to one of our tech-support representatives to determine if the tester should be returned for repair. Our return and service policies are designed to be simple and hassle free. Please follow the instructions listed in this binder when you feel you have a product that needs repair. If at any point in the process you are not happy with the service or support you receive from any member of the IPA® team, please email president@ipatools.com.

Step 1: Determine Type of Repair Needed

There are three types of repair:

Physically Broken – Tester has physical damage, i.e. switch snapped off, socket came loose, etc.

Erratic Behavior – Tester is not working properly, i.e. lights flashing, erroneous error warnings, etc.

Problems with Components/Accessories – Issues with items not in the main tester, i.e. remotes not programming, battery charger issues, etc.

Step 2: Determining Service Action

Many issues can be fixed over the phone with the help of one of our tech-support representatives. If you have an issue with one of our testers, call 888-786-7899 or email tech@ipatools.com to speak with one of our team members. They will determine the best level of service to provide.

There are three levels of repair:

Fix Over the Phone – Tech support will walk the customer through the repair over the phone. No parts or inhouse service is needed.

Field Repair – Tech support will send the required parts needed for the customer to service the tester in the field themselves.

In-House Repair – The customer will send the tester to the tech-support team for service at an IPA® facility.

Step 3: Acquire RGA

Once a tech-support representative determines the tester needs to be sent in for repair, an RGA # will be assigned along with next step instructions for the customer.

NOTE:

- Always take at least five pictures of your tester BEFORE sending the tester to the IPA® facility.
- IPA® is not liable for any damage that occurs to the tester during shipment.
- Consult a tech-support team member over the phone or via email before you send in any tester for repair. Testers with excessive sheet metal damage may not be eligible for repair and our tech may suggest another option, i.e. swap-out program or scratch and dent model.

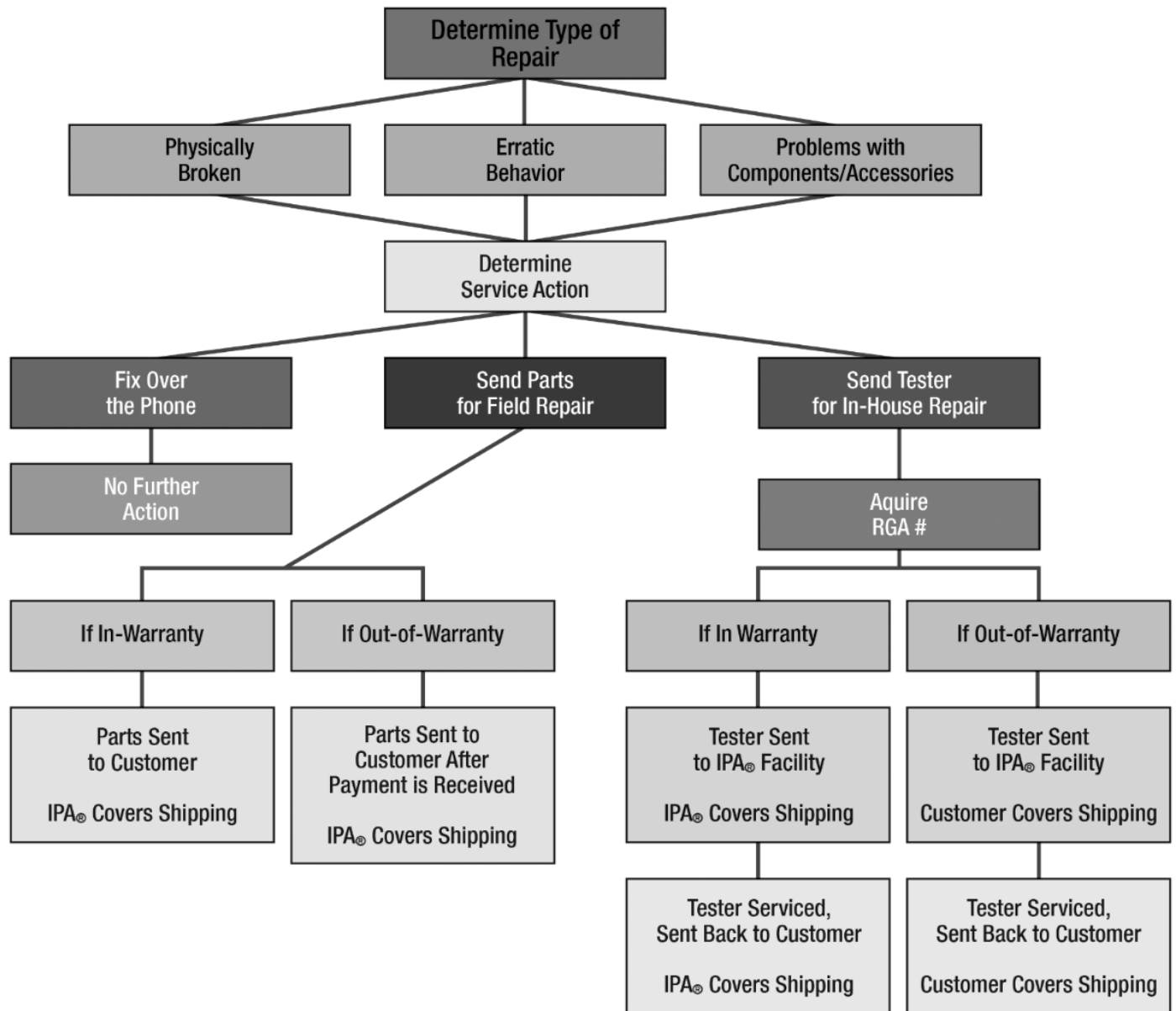

Examples of situations and parts not covered by out-of-warranty service: punctured tires, dented sheet metal, standard misuse and abuse, worn-out connectors due to excessive use, water/fire damage.

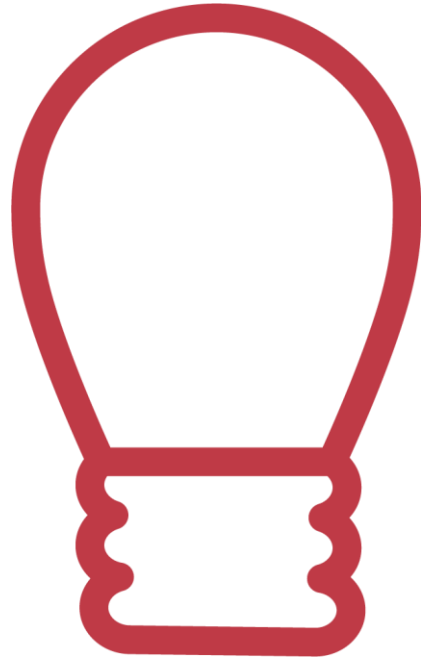

**PART 2:
ELECTRICAL,
LIGHTING AND
AIR BRAKE
TESTING**

PART 2: ELECTRICAL, LIGHTING AND AIR BRAKE TESTING

2.1 Electrical/Lighting Testing

The Alpha MUTT® is microprocessor controlled and features a special diagnostic firmware designed to seamlessly integrate with your preferred methods of testing. The Alpha MUTT® will power the selected electrical circuits and instantly alert you to any signs of a faulty condition. **To properly utilize the diagnostic features, a complete scan of the trailer's electrical system should be performed at the front of the trailer using the Alpha MUTT® prior to a walk-around inspection.** If any wiring faults are present, the tester will blink or sound, alerting you to the issue. Only a one-time, visual walk-around inspection is needed to confirm that each individual light bulb is properly illuminating.

NOTE: Some advanced functions may not be listed on the face panel, so it is important to read the manual in its entirety to ensure that you are getting the full use of this diagnostic system.

Pretest Checklist

The pretesting checklist should always be completed prior to using the Alpha MUTT®.

Tester Placement

- Secure Alpha MUTT® to workspace.
- Chock trailer wheels to avoid rolling before testing brakes.



Maintain Connectors

Dielectric grease should be used on all connections to avoid corrosion. If a bad connection exists at the terminal junction, you may get an erroneous reading and the MUTT® will not work properly.

- Make sure you have a solid connection in the socket.
- Be certain the 7 pins in each plug are clean and spread to the proper size.
- Always check the connector pins on the Alpha MUTT® for proper expansion. Over time, the pins may bend in slightly resulting in a poor connection between the connector and the cable ends. A flat head screwdriver can be used to expand the pins until a tight connection is made.

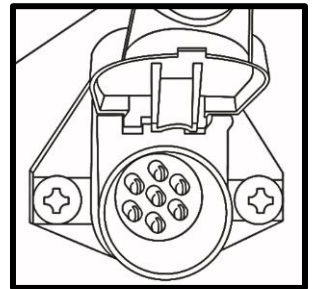

Cable Testing Procedure

The Alpha MUTT® has a unique feature to test 7-way round pin cables for continuity. The cable testing feature can be used to test a tractor's cable or the supplied 7-way cable. All cables should be tested prior to operation.

- Insert each end of the cable into both connectors on the tester. Be sure to push the cable ends in firmly until they reach the bottom of the connector.
- Turn Power Source switch to a desired power supply.
- The green lights around the Circuit Control knob will blink and disappear one at a time until only the Ground Integrity indicator remains solid green. Once the initial check has been performed, poor cable conditions will be shown by a blinking light for the problem circuit.
- If the cable has an open circuit or continuity problem, the corresponding circuit will flash repeatedly.
- Further testing can be performed by selecting each circuit individually via the Circuit Control knob or remote. When an open circuit is detected, the LED for the circuit will flash and an audible alert will be heard.

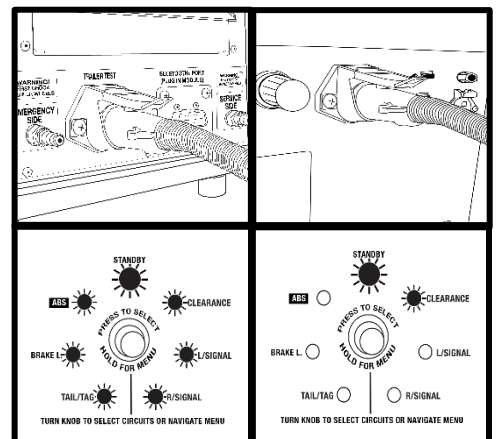

WARNING: Always check that the 7 pins in the plug are clean and spread to the proper size.

2.2 Selecting a Circuit

Circuits can be selected for testing manually with the control knob, with the remote control and tablet, or by initiating Auto Cycle mode.

Manually

Turn the Circuit Control knob to select a circuit. The control knob is automatically set to Ground Integrity when power is turned on.

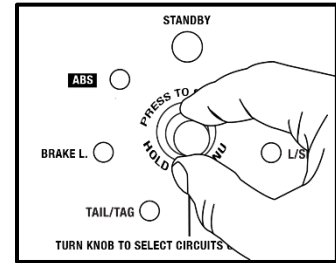

12-Button Remote Control

Press and release the desired circuit button. Hold the button to lock the desired circuit on.

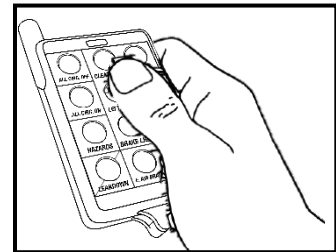

Tablet

Use either the Classic View or Remote View for basic controls on the tablet or use Diagnostic View for advanced controls.



Change View



Swipe Screen for Diagnostics View

Autocycle Mode

Autocycle mode automatically tests one circuit at a time in a clockwise rotation.

Manually

1. To initiate, access Autocycle mode as a shortcut setting via the Shortcut button, or via the function menu which is located as a submenu in the main system settings.
2. A five-second delay commences between circuit sections.
3. Circuits are automatically tested one at a time in a clockwise rotation.
4. To cancel Autocycle mode, momentarily press or rotate the control knob.

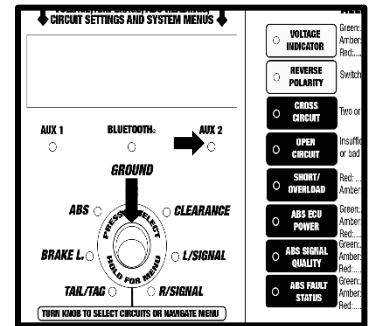

12-Button Remote Control

1. Press and hold the All Circ. On button on the 12-button remote.
2. A five-second delay commences between circuit sections.
3. Circuits are automatically tested one at a time in a clockwise rotation.
4. To cancel Autocycle mode, momentarily press or rotate the Circuit Control knob.

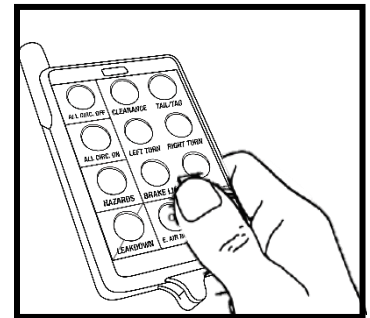

Tablet

Use either the Classic View or Remote View for basic controls on the tablet or use Diagnostic View for advanced controls. Press the Autocycle button to begin.



NOTE: Autocycle mode does not work when ABS or Brake Light circuits are selected.

2.3 Ground Integrity Test

Each time the Alpha MUTT® is powered on, it automatically runs a Ground Integrity test. A good ground connection must be established for the Alpha MUTT® to operate a trailer's electrical system.

1. Immediately after powering up, the green lights around the Circuit Control knob will illuminate.
2. A solid/healthy ground connection is indicated by a steady illuminated Ground Integrity indicator.

NOTE: The Alpha MUTT® cannot monitor ground condition while selecting circuits. A sudden loss of ground while testing circuits will present as open circuits on each selected circuit. To confirm ground status, turn selector knob back to the ground position. While in ground position, the Alpha MUTT® continuously monitors the ground status.

3. Bad/poor ground or bad cable condition is indicated by all the LEDs blinking simultaneously. See the section titled Establishing a Chassis Ground below.
4. When one or more green circuit LEDs blink while the Ground Integrity indicator is steadily illuminated, it indicates that a solid ground has been established, but an open circuit has been detected. Refer to the section titled Fault Indication - Open Circuit.

Chassis and Pin Grounds

A poor ground warning may be an indication that the connected trailer is only wired for chassis ground. There are two ground types. 1) Pin ground: The ground wire from each light assembly is wired through the main harness up into the trailer plug. 2) Chassis ground: The ground wire from each light assembly is grounded directly to the trailer chassis. Ground with the truck is established at the king pin.

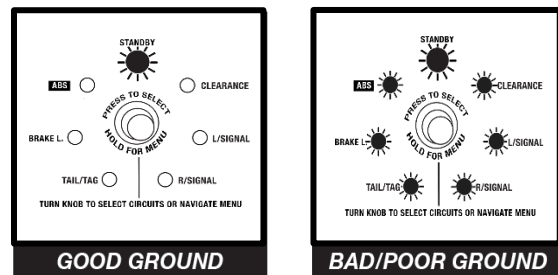

Establishing a Chassis Ground

1. To simulate the king pin on a chassis ground connection and bypass the ground integrity fault, plug a chassis ground cable into the Chassis Ground outlet on the front, bottom panel of the Alpha MUTT®.
2. Attach the other end of the chassis ground cable to the chassis of the trailer.
3. Be sure that you are attaching to a clean, dry metal for an effective ground.

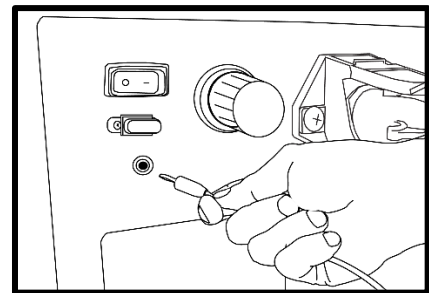

NOTE: DO NOT assume a bad ground warning is a result of a faulty trailer. Check cable connection.

2.4 Fault Indication

Open Circuit

An open circuit fault warning is triggered when the circuit draws under 4mA of power. The Alpha MUTT® has a circuit detection resolution of 1mA. (A single LED with an LED bulb will draw 5-7mA of current.) When the Alpha MUTT® senses no load, it is often a symptom of a disconnected wire, cut wire, poor pin connection or bad return ground. The tester can detect open circuits in two ways:

1. During ground integrity test: An individual circuit will blink and no audible alerts will be present.
2. During circuit selection: The LCD screen will indicate the type of fault. The corresponding circuit LED and alert indicator will flash, and the tester will provide an audible alert (beep).

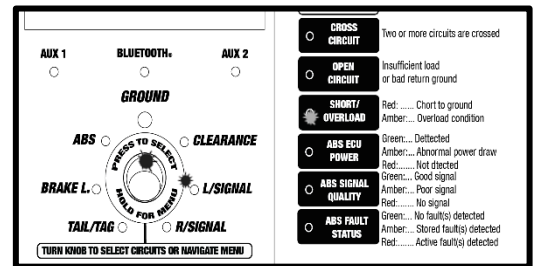

NOTE: Open Circuit fault indicator will only illuminate during circuit selection.

Crossed Circuits

The Alpha MUTT® indicates that two or more circuits are back feeding or crossed. This can be a symptom of two wires in the same harness wearing through their insulated coating and connecting.

1. When a crossed circuit is identified, the LCD screen will display "CROSS CIRCUIT". The circuit LED that should not be powered and needs correcting will flash, and the tester will provide an audible alert (beep).

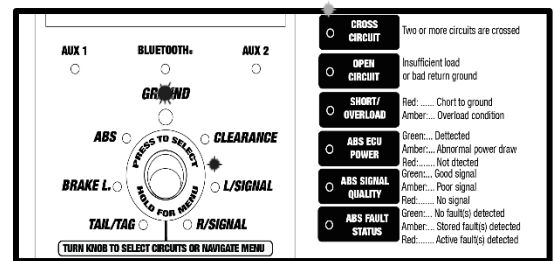

NOTE: In some cases, a crossed circuit may be a normal function of advanced diagnostic testing, such as with certain ABS systems.

Short/Overloaded Circuit

Short circuits or overloads can occur when a positive/hot wire touches ground or the load on the circuit exceeds the allowable current or amperage draw (factory default 21 amps). A short or overload can also be a result of faulty lights or poor connections.

1. If a short or overloaded circuit is suspected, the Alpha MUTT® will instantly suspend power for three seconds and enter Pulsar® mode until the short is removed.
2. The LCD screen will indicate the type of fault. The corresponding circuit LED and alert indicator will flash, and the tester will provide an audible alert (beep).
3. During Pulsar® mode, the Alpha MUTT® enters a three-second countdown sequence. When the countdown completes, the tester will attempt to restore power to the circuit. If a short is still present, steps 1-3 will automatically repeat.

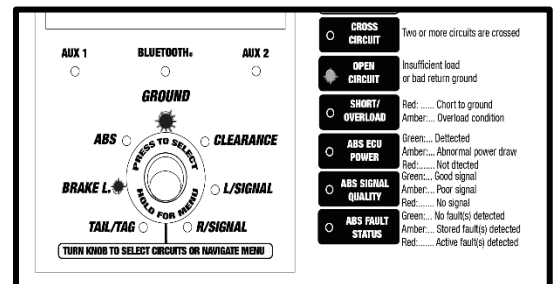

NOTE: Pulsar® mode can be a useful troubleshooting tool for finding dead and intermittent shorts.

2.5 Activating Hazard Lights

The four-way flashers on the vehicle can be activated manually, with the remote controls or via the tablet.

Manually

Access Hazard mode as a shortcut setting via the Shortcut button.

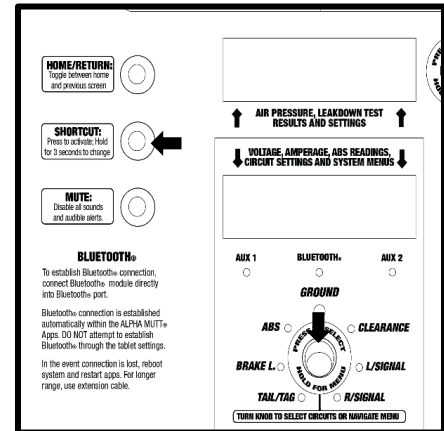

12-Button Remote Control

Press the Hazards button to activate.

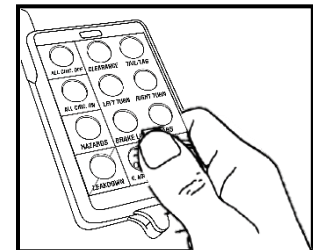

Tablet

To activate, press the Hazards button on either Classic View or Remote View.

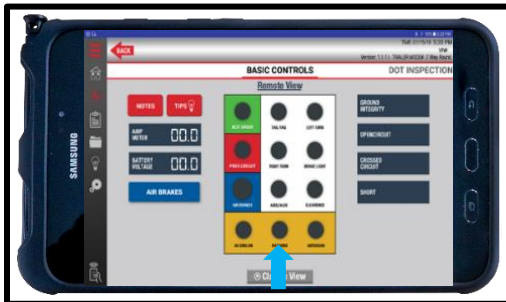

2.6 All Circuits On (Override) Mode

All Circuits On mode will engage all electrical circuits at the same time. While short circuit sensing is operational in this mode, if a short circuit is found, the Alpha MUTT® will not be able to identify which circuit is the cause of the short. Open and crossed circuit sensing is not operational in this mode.

On trailers using incandescent bulbs, All Circuits On mode will typically result in an overload because the amperage draw will exceed the 20 amp maximum.

All Circuits On mode can be accessed manually, by remote control or with the tablet.

Manually

Access All Circuits On mode as a shortcut setting via the Shortcut button.

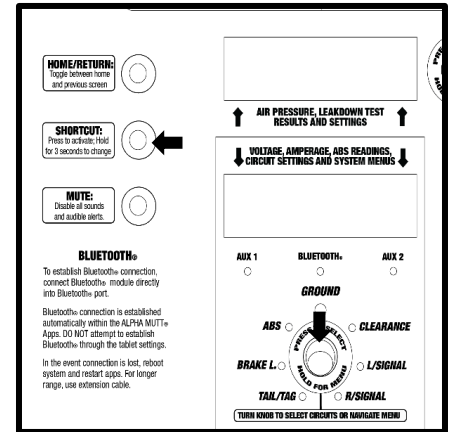

12-Button Remote Control

To activate, press the All Circ. On button.

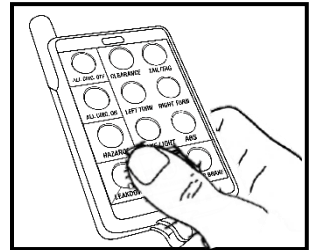

Tablet

To activate, press the All Circ. On button on either Classic View, Remote View or Diagnostics View.

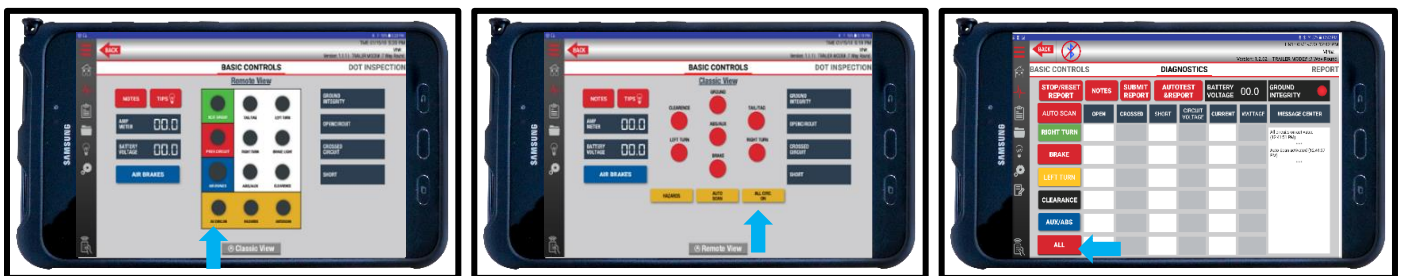

2.7 Air Brake Testing Set-Up



DANGER



CHOCK TRAILER WHEELS

WARNING!!! DO NOT CONNECT SHOP AIR UNTIL COMPLETING THE TESTING SET-UP PROCEDURE. FAILURE TO FULLY UNDERSTAND THESE WARNINGS CAN RESULT IN MINOR TO SERIOUS INJURY AND POSSIBLY DEATH.

NOTE: The Alpha MUTT® is equipped with a safety feature which requires the user to acknowledge the vehicle's tires are securely chocked prior to testing. Until this is completed, the tester will not allow operation of the air brake controls.

1. Push the Power Source switch to the ON position.
2. Attach gladhand hoses from the Alpha MUTT® directly to your trailer's air system, securing the red hose to the Emergency Side and the blue hose to the Service Side.
3. Connect your shop air to the Shop Air inlet on the tester.
4. Listen for any air leaks where the shop air connects to the tester to avoid erroneous results.

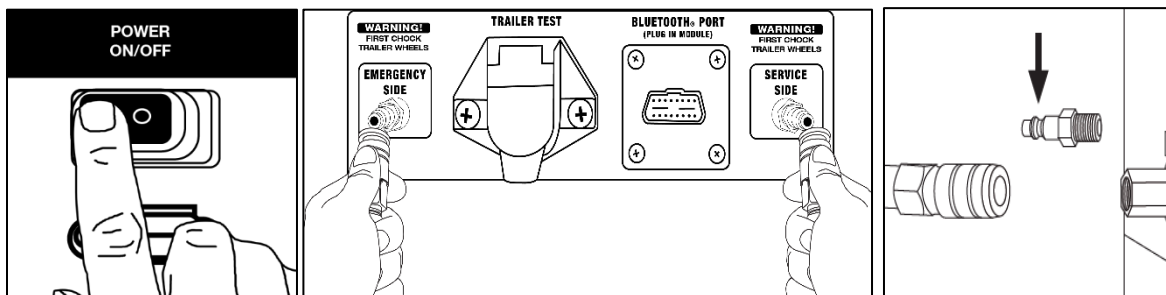

5. Press the Start/Air In button to view Emergency Side air pressure on the Upper LCD screen, then adjust with regulator(s) to the desired psi.
6. Press the Apply Brake button on the Service Side to allow the air to fill the system. View the pressure reading on the Upper LCD screen.
 - a. If your tester is equipped with the optional Service Side regulator, adjust it to the desired psi.

NOTE: Single regulator systems will adjust pressure for both the Emergency and Service Sides.

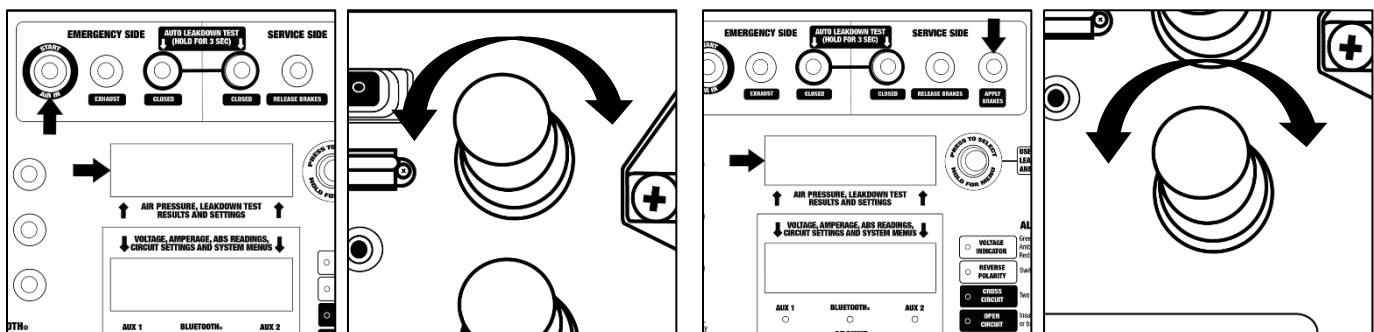

2.8 Actuating Air Brakes

This feature allows you to see the slacker adjustments and the pushrod travel in real time. Brakes can be activated manually with the remote controls or via the tablet.

NOTE: The Alpha MUTT® is equipped with a safety feature which requires the user to acknowledge the vehicle's tires are securely chocked prior to testing. Until this is completed, the tester will not allow operation of the air brake controls.

Actuate Air Brakes Manually

1. Fill the system to the desired working pressure by pressing the Start/Air In button on the Emergency Side.
2. Adjust the regulator to the desired psi.
3. Pressurize the Service Side by pressing the Apply Brake button.
 - a. If your tester is equipped with the optional Service Side regulator, adjust it to the desired psi.
4. To release the brakes, press the Release Brake button on the Service Side.
5. To exhaust the entire system, press the Exhaust button on the Emergency Side.

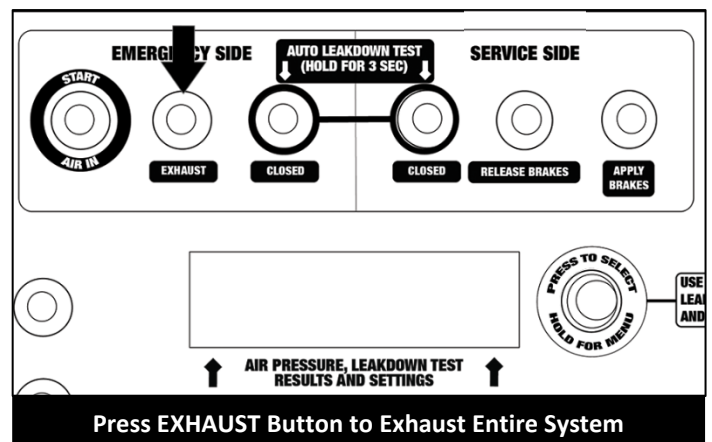
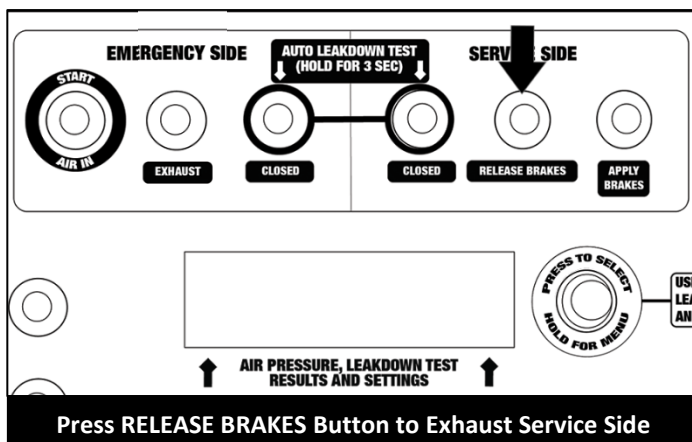
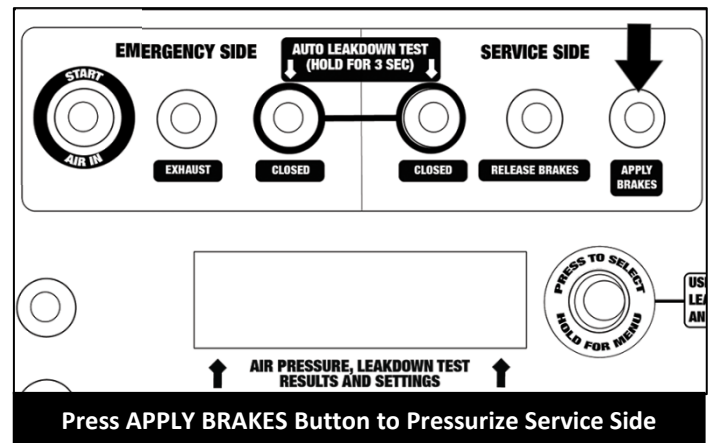
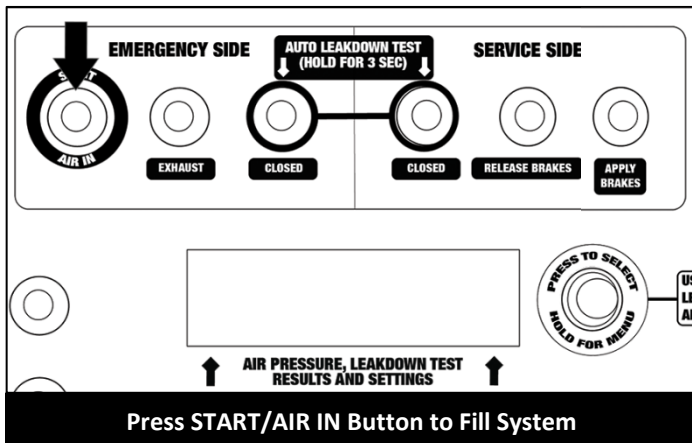

Actuate Air Brakes with 12-Button Remote Control

1. Press the E. Air Brake button to charge the Emergency Side to the desired working pressure.
2. Press the S. Air Brake button once to apply the service air brakes.
3. Press the S. Air Brake button again to release the brakes.
4. Repeat as necessary.



Actuate Air Brakes with the Tablet

1. Charge the Emergency Side to the desired working pressure.
2. Press the Start/Air In button on the Emergency Side to engage air testing.
 - a. Follow safety prompts and remember to chock trailer wheels prior to testing.
3. Press the Air Brakes button on either the Classic or Remote View on the tablet to engage the service air brakes.
4. Press the Air Brakes button on the tablet again to disengage the brakes.
5. Repeat as necessary.

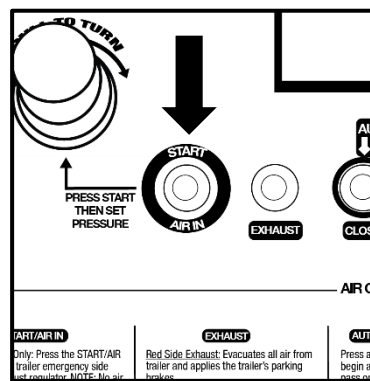

2.9 Leakdown Testing

Leakdown Testing can be performed manually or through an automatic test which displays pass or fail results.

WARNING: DO NOT connect shop air until completing the testing set-up procedure. Failure to fully understand these warnings can result in minor to serious injury and possibly death.

NOTE: The Alpha MUTT® is equipped with a safety feature which requires the user to acknowledge the vehicle's tires are securely chocked prior to testing. Until this is completed, the tester will not allow operation of the air brake controls.

Manual Leakdown Test

A Manual Leakdown Test simply means the user fills up one or both sides of a trailer's air brake system with air to the desired pressure, then stops the air flow and monitors the pressure loss over time by viewing the real-time psi readings on the Upper LCD screen.

1. Complete the steps in the Testing Set-Up and Actuating Air Brakes sections.
2. 120 psi is the recommended testing value. Press the Close button on the Emergency Side and then on the Service Side.
3. Use a countdown timer and observe pressure loss over time. Follow your company's recommended leakdown tolerance to determine if the amount of pressure loss observed falls within the allowable limits.

EXAMPLE: Some fleets allow for 1 psi loss per minute. If the tester shows a loss of 2 psi after 3 minutes, the trailer passes the Leakdown Test. If the tester shows a loss of 4 psi after 3 minutes, the trailer fails the Leakdown Test.

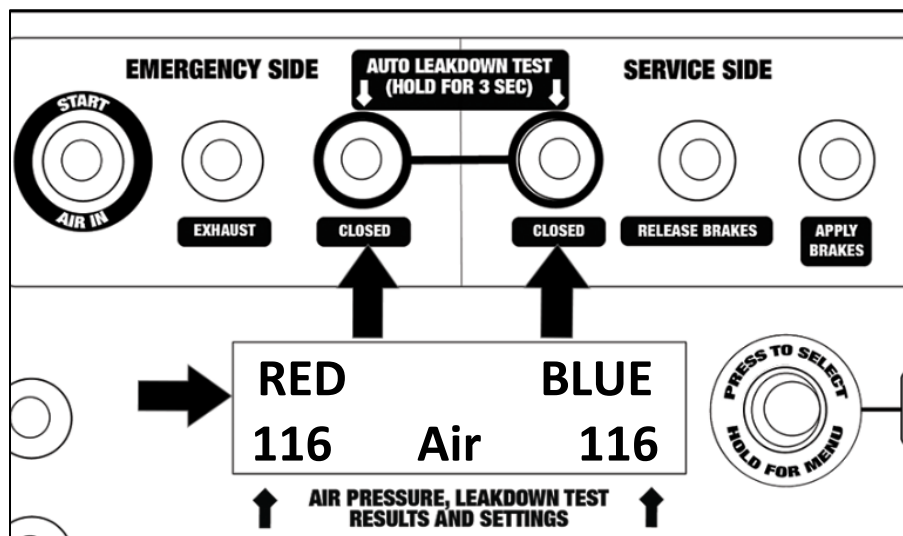

Automatic Leakdown Test

An Automatic (AUTO) Leakdown Test allows a technician/operator to perform a test with preset pass/fail parameters (time and acceptable psi loss). The Alpha MUTT® will conduct the Leakdown Test and display results when complete. Refer to the section titled Electrical Inspections for more information.

1. Complete the steps in the Testing Set-Up and Actuating Air Brakes sections. If these steps are not completed, the Automatic Leakdown Test will not begin, and the tester will alert the user.
2. Press and hold the Close button on both the Emergency and Service Sides simultaneously for three seconds.
3. Follow the prompts on the LCD screen to complete the test.

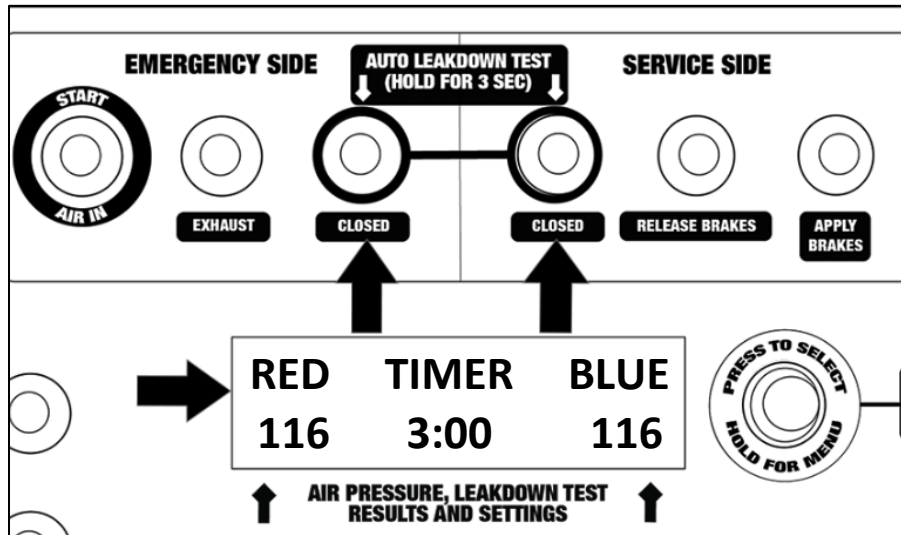

Changing Automatic Leakdown Test Parameters

1. Press and hold the lower control knob for three seconds. Turn the knob to select the settings option. Then press and release the lower control knob again.
2. Follow the LCD screen prompts to set test time, test pressure, and allowable psi loss/tolerance.

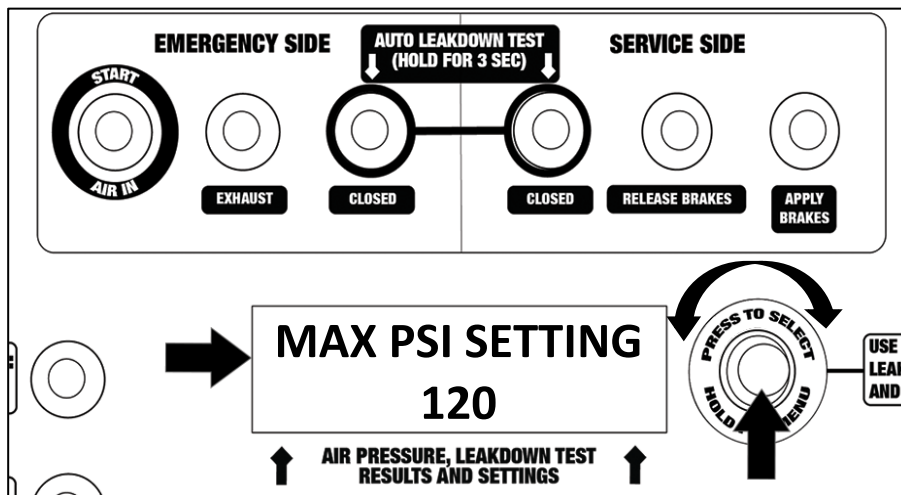



PART 3: ABS TESTING

PART 3: ABS TESTING

3.1 Accessing ABS Codes

The Alpha MUTT® is equipped with integrated ABS diagnostics and can access and clear ABS fault codes. The Alpha MUTT® allows a technician to access ABS diagnostics via the upper LCD screen on the control panel or software app on the tablet.

ABS Explained

Modern trailers with ABS systems store fault codes when an error or malfunction occurs. Trailers with ABS systems typically have an amber colored light labeled “ABS” located on the road side of the trailer. When an active fault is present, these lights illuminate, alerting the driver or technician that there is an active fault within the ABS system. When an ABS fault is active, the problem must be resolved, and the ABS light cleared for the trailer to pass inspection. ABS system faults are often associated with open circuits and loss of communication to the wheel speed sensors, or loss of power to the ABS ECU. While there are several ABS manufacturers, they all generally follow the SAE recommendations for how to display codes. These codes are traditionally accessed through two methods.

The simple analog method is commonly referred to as the Blink Code method. Each manufacturer differs in the way blink codes are initiated. Blink codes are a slower and more tedious way of retrieving ABS information with the major deficiency being most manufacturers do not allow codes to be cleared via the Blink Code Method.

The method of using a scan tool to retrieve codes is commonly referred to as the Digital Fault method. Digital fault codes can be viewed along with the definition of the fault on the screen which improves troubleshooting time. The digital method also allows for codes to be cleared which prevents the technician from having to jack up the trailer and spin the wheels or pull it down the road just to clear a code.

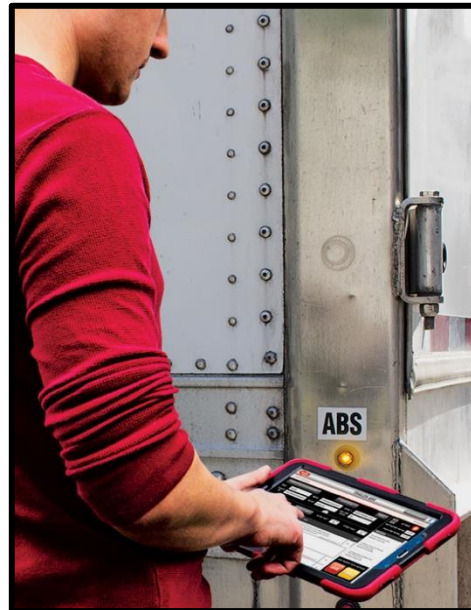
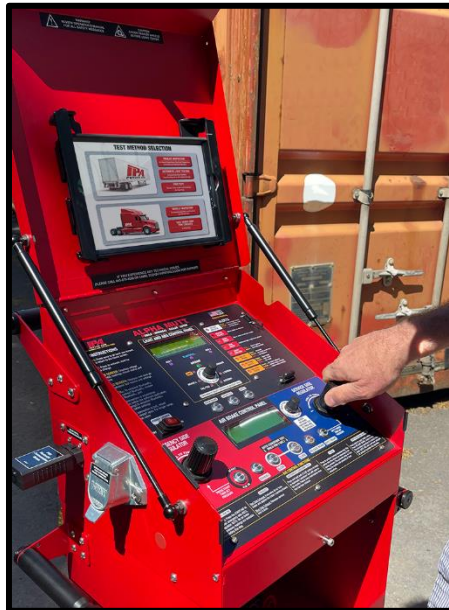

SUPPORT LINKS AND INFORMATION: If you suspect an issue with the tester’s software or hardware, please call IPA® at 888-786-7899 or email tech247@ipatools.com.

For issues with the trailer or ECU modules, please contact the ABS ECU Manufacturer. The most common manufacturers are Meritor (www.meritor.com), WABCO (www.wabco-auto.com), Haldex (www.haldex.com), Bendix (www.bendix.com) and Gen2 (www.den2abs.com).

3.2 Manual Controls

METHOD #1 – LCD screen on the control panel.

(Must select power source then ABS circuit for this operation.)

In this method, the user must use both the press function and the turn function of the control knob to access various menus and read through ABS troubleshooting information that is available within the LCD screen.

Once the tester is turned on and ABS is detected, you can turn the Main Control knob to cycle through menus or sub-menus. Press the control knob to access the sub-menus.

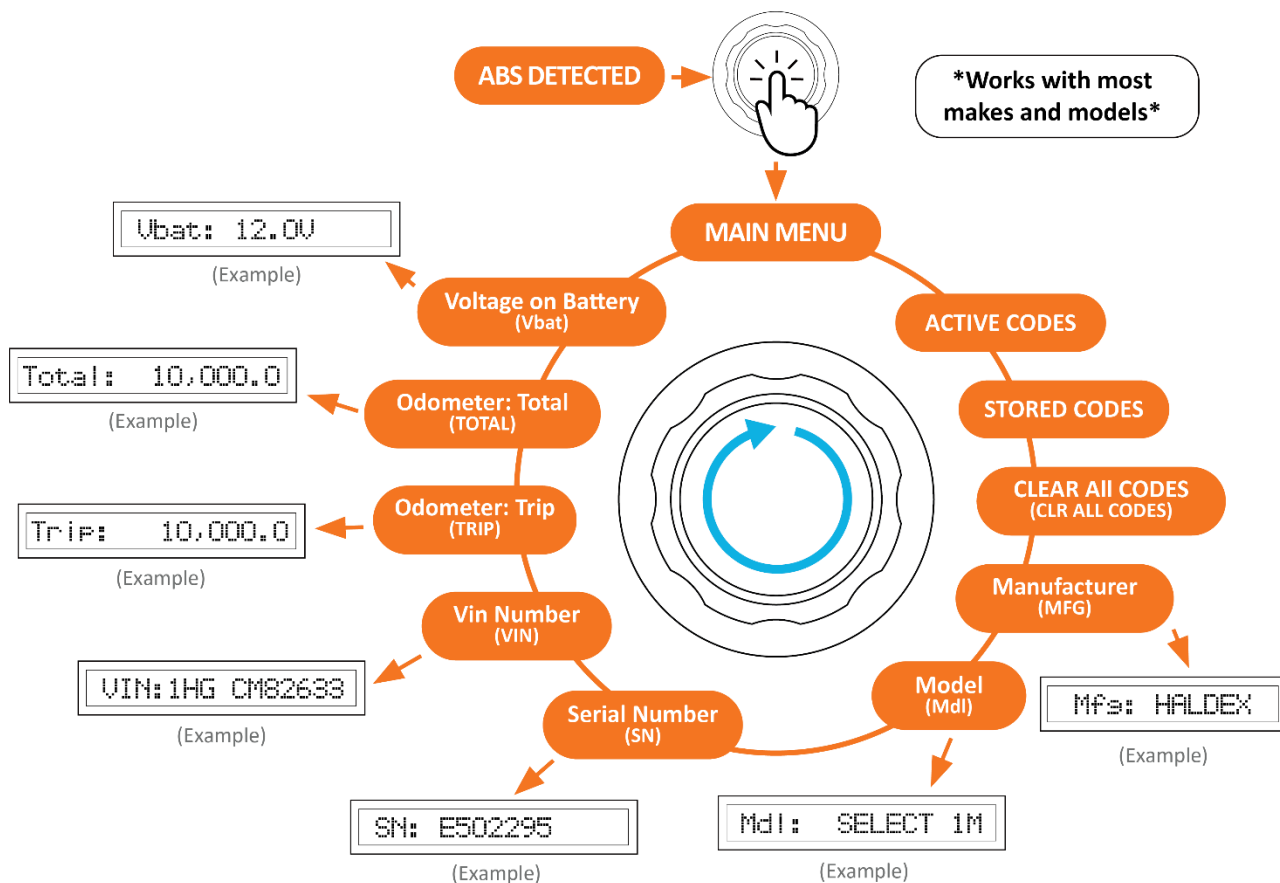

NOTE: Turning the control knob clockwise allows you to scroll through each sub-menu. Turning the control knob counterclockwise will back you out one sub-menu at a time.

The Alpha MUTT® communicates with the trailer's ABS ECU in real time, via IPA®'s proprietary internal ABS PLC communication module. This module is automatically activated as long as the ABS/AUX circuit is selected/powered up by the Alpha MUTT®. Once activated, the ABS module will send information request commands to the trailer's ECU. The trailer's ECU will automatically broadcast back the ECU make, model, VIN, and mileage along with other basic information. This information is then stored inside the internal computer of the Alpha MUTT®.

When fault codes or clear fault commands are requested, the ABS PLC communication module will send the command to the trailer's ECU. The user must then request fault codes again to verify that there are no active faults. Each Alpha MUTT® provides ABS data status lights which indicate the status of information either being sent to the trailer in the form of commands, or information being broadcasted from the trailer to the tester. When troubleshooting ABS connectivity issues, it is imperative for the technician to view these status LEDs. Failing to view the status LEDs could result in false assumptions such as a faulty ABS computer, broken ABS light and others.

Accessing Active Faults (Sub-Menu #1)

With the ACTIVE FAULTS Sub-Menu 1 selected and the Active SID and FMI codes displayed, turn the control knob clockwise to cycle through fault codes (Fig. 1-A). Press the control knob (Fig. 1-B) to read the Fault Description (Fig. 1-C).

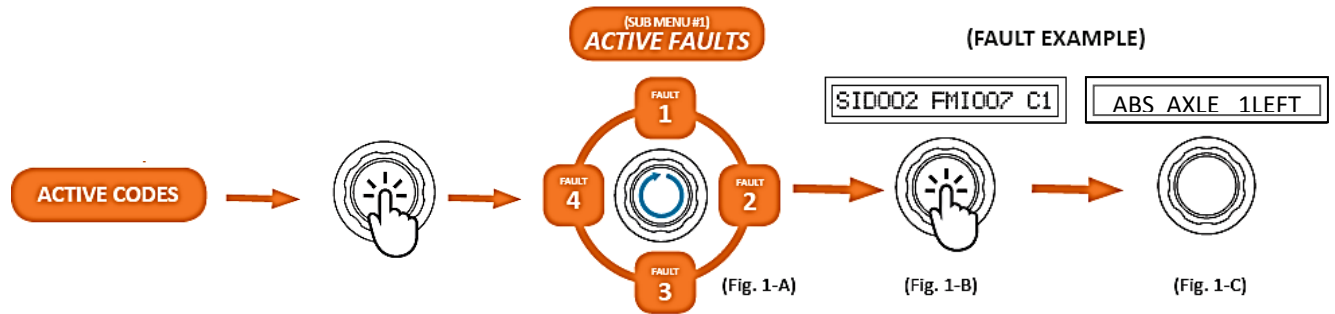

Accessing Stored Faults (Sub-Menu #2)

With the STORED FAULTS Sub-Menu 2 selected and the Stored SID and FMI codes displayed, turn the control knob clockwise to cycle through fault codes (Fig. 2-A). Press the control knob (Fig. 2-B) to read the Fault Description (Fig. 2-C).

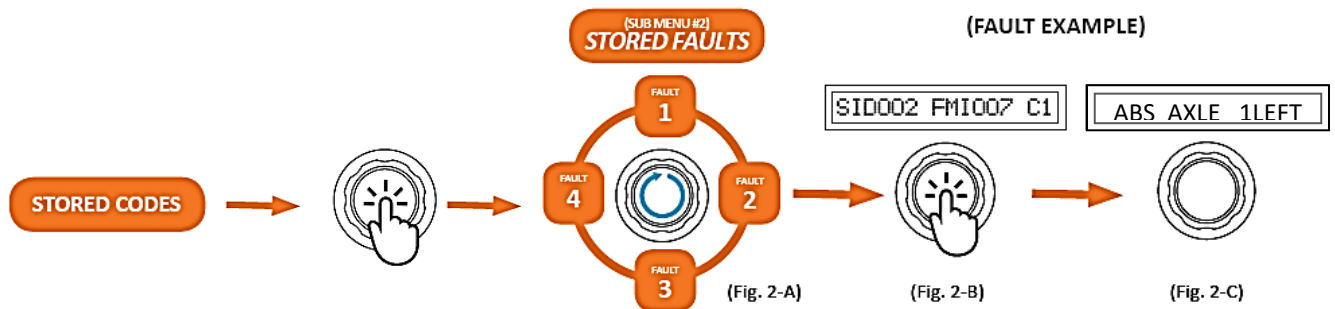

Clear All Codes (Sub-Menu #3)

With the CLR ALL CODES Sub-Menu 3 selected, the screen will display CLR? NO/YES. Turn the control knob to YES or NO depending on your desire (Fig. 3A). Press the control knob to make your selection (Fig. 3-B).



NOTE: You can only clear stored codes. Clearing a code will return you to the main menu.

3.3 Tablet Controls

METHOD #2 – Tablet via ABS app.

In this method, the ECU information, clear faults command, code definitions and troubleshooting information are all displayed on one screen.

The ABS app can be found on the Home screen of the tablet. Press the  icon to launch the app. The app is designed to be intuitive and easy to use. Review the following pages for basic operation flow and further instructions. For technical assistance, please call 888-786-7899

NOTE: The ABS app provided with the Alpha MUTT[®] was launched in 2019. IPA[®] updates the app periodically to increase functionality. If you have any suggestions for updates, please email tech247@ipatools.com or call 845-786-7899.

1. With the Alpha MUTT[®] powered on, ensure it is paired with the tablet via Bluetooth[®].
2. Select the ABS/AUX1 circuit on the tester's face.
3. Press REQUEST ABS ECU INFORMATION to populate the MAKE, MODEL, SERIAL #, TRAILER VIN, MILEAGE and ABS LAMP STATUS fields. The ABS CIRCUIT STATUS light will illuminate green and the BATTERY VOLTAGE field will also populate.
4. Press REQUEST FAULTS to populate the lower portion of the screen with any ACTIVE or STORED FAULTS.
5. Press TROUBLESHOOTING INFO located in the CAUSE area to show additional information for each fault.



NOTE: Bluetooth[®] should auto pair with the tester. Press the icon to disconnect or re-establish connectivity.

3.4 Failure Mode Identifier (FMI) Assignments

The Failure Mode Identifier (FMI) describes the type of failure detected in the subsystem identified by the PID or SID. The FMI and either the PID or SID combine to form a given diagnostic code (see PID 194 for added clarification). The remaining failure mode identifiers would be assigned by the SAE Truck and Bus Low Speed Communications Network Subcommittee if additional common failure modes become detectable.

0	Data valid but above normal operational range (that is, engine overheating)
1	Data valid but below normal operational range (that is, engine oil pressure too low)
2	Data erratic, intermittent or incorrect
3	Voltage above normal or shorted high
4	Voltage below normal or shorted low
5	Current below normal or open circuit
6	Current above normal or grounded circuit
7	Mechanical system not responding properly
8	Abnormal frequency, pulse width or period
9	Abnormal update rate
10	Abnormal rate of change
11	Failure mode not identifiable
12	Bad intelligent device or component
13	Out of Calibration
14	Special Instructions
15	Reserved for future assignment by the SAE Subcommittee

3.5 SAE J1587 Mid 137 Sid List

Brake SIDs (MIDs = 136, 137, 138, 139, 246, 247)	
0	Reserved
1	Wheel Sensor ABS Axle 1 Left
2	Wheel Sensor ABS Axle 1 Right
3	Wheel Sensor ABS Axle 2 Left
4	Wheel Sensor ABS Axle 2 Right
5	Wheel Sensor ABS Axle 3 Left
6	Wheel Sensor ABS Axle 3 Right
7	Pressure Modulation Valve ABS Axle 1 Left
8	Pressure Modulation Valve ABS Axle 1 Right
9	Pressure Modulation Valve ABS Axle 2 Left
10	Pressure Modulation Valve ABS Axle 2 Right
11	Pressure Modulation Valve ABS Axle 3 Left
12	Pressure Modulation Valve ABS Axle 3 Right
13	Retarder Control Relay
14	Relay Diagonal 1
15	Relay Diagonal 2
16	Mode Switch ABS
17	Mode Switch ASR
18	DIF 1—ASR Valve
19	DIF 2—ASR Valve
20	Pneumatic Engine Control
21	Electronic Engine Control (Servomotor)
22	Speed Signal Input
23	Tractor ABS Warning Light Bulb
24	ASR Light Bulb
25	Wheel Sensor, ABS Axle 1 Average
26	Wheel Sensor, ABS Axle 2 Average
27	Wheel Sensor, ABS Axle 3 Average
28	Pressure Modulator, Drive Axle Relay Valve
29	Pressure Transducer, Drive Axle Relay Valve
30	Master Control Relay
31	Trailer Brake Slack Out of Adjustment Forward Axle Left
32	Trailer Brake Slack Out of Adjustment Forward axle Right
33	Trailer Brake Slack Out of Adjustment Rear Axle Left
34	Trailer Brake Slack Out of Adjustment Rear Axle Right
35	Tractor Brake Slack Out of Adjustment Axle 1 Left
36	Tractor Brake Slack Out of Adjustment Axle 1 Right
37	Tractor Brake Slack Out of Adjustment Axle 2 Left
38	Tractor Brake Slack Out of Adjustment Axle 2 Right
39	Tractor Brake Slack Out of Adjustment Axle 3 Left
40	Tractor Brake Slack Out of Adjustment Axle 3 Right
41	Ride Height Relay
42	Hold Modulator Valve Solenoid Axle 1 Left
43	Hold Modulator Valve Solenoid Axle 1 Right
44	Hold Modulator Valve Solenoid Axle 2 Left
45	Hold Modulator Valve Solenoid Axle 2 Right
46	Hold Modulator Valve Solenoid Axle 3 Left
47	Hold Modulator Valve Solenoid Axle 3 Right
48	Dump Modulator Valve Solenoid Axle 1 Left
49	Dump Modulator Valve Solenoid Axle 1 Right
50	Dump Modulator Valve Solenoid Axle 2 Left
51	Dump Modulator Valve Solenoid Axle 2 Right
52	Dump Modulator Valve Solenoid Axle 3 Left
53	Dump Modulator Valve Solenoid Axle 3 Right
54	Hydraulic Pump Motor
55	Brake Light Switch 1

56	Brake Light Switch 2
57	Electronic Pressure Control, Axle 1
58	Pneumatic Back-up Pressure Control, Axle 1
59	Brake Pressure Sensing, Axle 1
60	Electronic Pressure Control, Axle 2
61	Pneumatic Back-up Pressure Control, Axle 2
62	Brake Pressure Sensing, Axle 2
63	Electronic Pressure Control, Axle 3
64	Pneumatic Back-up Pressure Control, Axle 3
65	Brake Pressure Sensing, Axle 3
66	Electronic Pressure Control, Trailer Control
67	Pneumatic Back-up Pressure Control, Trailer Control
68	Brake Pressure Sensing, Trailer Control
69	Axle Load Sensor
70	Lining Wear Sensor, Axle 1 Left
71	Lining Wear Sensor, Axle 1 Right
72	Lining Wear Sensor, Axle 2 Left
73	Lining Wear Sensor, Axle 2 Right
74	Lining Wear Sensor, Axle 3 Left
75	Lining Wear Sensor, Axle 3 Right
76	Brake Signal Transmitter
77	Brake Signal Sensor 1
78	Brake Signal Sensor 2
79	Tire Dimension Supervision
80	Vehicle Deceleration Control
81	Trailer ABS Warning Light Bulb
82	Brake Torque Output Axle 1 Left
83	Brake Torque Output Axle 1 Right
84	Brake Torque Output Axle 2 Left
85	Brake Torque Output Axle 2 Right
86	Brake Torque Output Axle 3 Left
87	Brake Torque Output Axle 3 Right
88	Vehicle Dynamic Stability Control System (VDC)
89	Steering Angle Sensor
90	Voltage Supply for Stability Control System
91	Brake Lining Display
92	Pressure Limitation Valve
93	Auxiliary Valve
94	Hill holder System
95	Voltage Supply, Lining Wear Sensors, Axle 1
96	Voltage Supply, Lining Wear Sensors, Axle 2
97	Voltage Supply, Lining Wear Sensors, Axle 3
98	Reference Ground Connection
99	Lateral Accelerometer
100	Brake Light Relay
101	Brake Warning Light Bulb
102	Differential Lock control output (transfer case)
103	Yaw Rate Sensor
104	Service Odometer
105–150	Reserved for future assignment by SAE

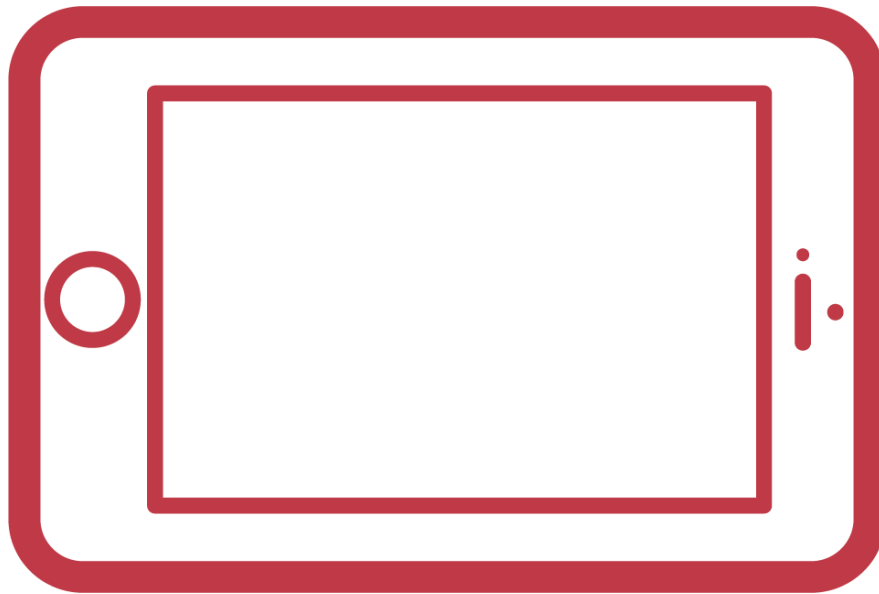

**PART 4:
USING THE
ALPHA MUTT®
APP**

PART 4: USING THE ALPHA MUTT® APP

4.1 Alpha MUTT® Application Setup



The Alpha MUTT® app can be found on the Home screen of the tablet. Press the  icon to launch the app. It is designed to be intuitive and easy to use. Review the following pages for basic operation flow and further instructions. For technical assistance, please call 888-786-7899.

Accounts

Password-protected user accounts can be created for each technician. To access the Settings menu, you must sign in as administrator. By default, the administrator password is set as “admin”. The Settings menu can be accessed by pressing the Settings icon on the left side of the screen. Once in the Settings menu, slide the screen left or right to cycle through the various setting options.

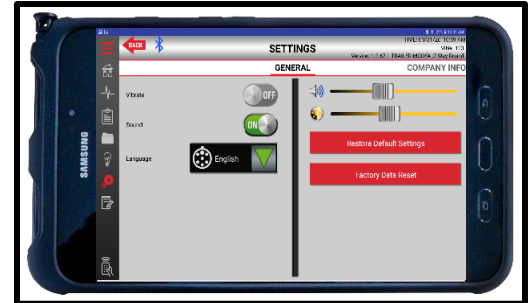

Company Information

Users can enter company name, addresses, phone numbers, emails and logos for reports.

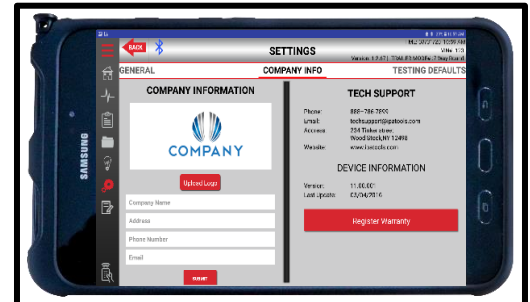

Testing Defaults

Users can decide which features of the application appear in normal testing screens by enabling or disabling them in the Settings menu.

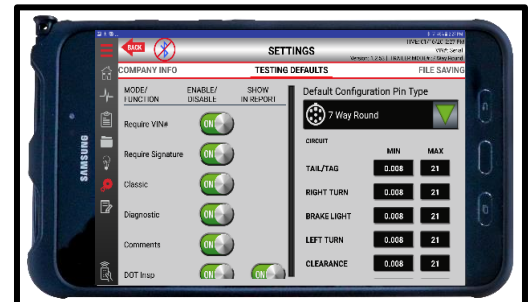

4.2 Menu Bar Screens



Home Screen



Testing Screen



Notes Screen



Reports Screen



Help Screen

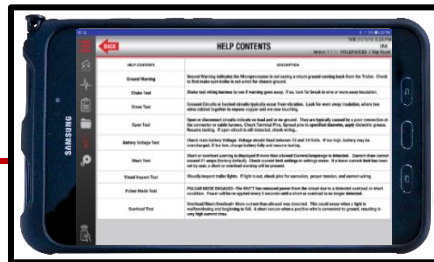

Settings Screen

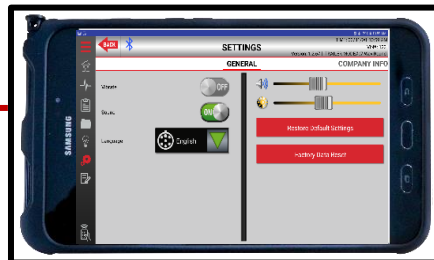

(Multiple)

Inspection Creator Screen

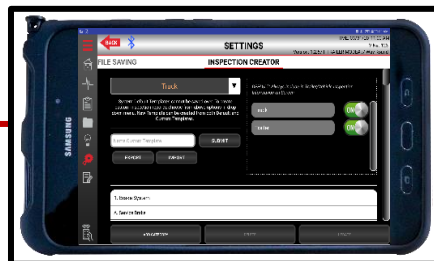

Optional Classic Views for Diagnostics - Swipe right to access

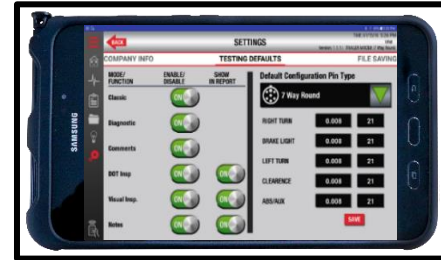
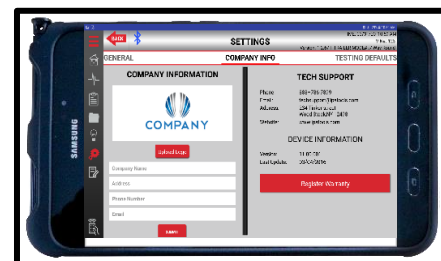

Sideswipe for alternate screens

4.3 Diagnostic Controls



A. Stop/Reset Report

Press once during diagnostics to stop report before completion. Press again to clear all diagnostics reported.

B. Notes

Press to log a note with report. Notes can be viewed on the Notes List page or on the report once completed.

C. Submit Report

Submits report for saving. A test must be executed before a report can be submitted.

D. Auto-Test & Report

Automatically tests one circuit at a time in a clockwise rotation then submits report.

E. Battery Voltage

Displays battery voltage when connected.

F. Ground Integrity

Red light indicates a bad/poor ground or bad cable condition. Green light indicates a solid/healthy ground connection.

G. Auto Scan

Engages all electrical circuits at the same time.

H. Available Circuits

Pressing any one of these buttons will initiate a test of the selected circuit, noting circuit conditions, voltage, current and wattage.

I. Message Center

Shows messages relating to tested circuits.

4.4 Electrical Inspections

The Alpha MUTT® app performs wireless diagnostic electrical tests and PM inspections. It includes an Inspection Creation feature which allows users to create custom DOT and PM inspections and generates, stores and shares reports via email. Sharing reports requires an email account to be set up on the tablet.

1. With the Alpha MUTT® powered on, ensure it is paired with the tablet via Bluetooth®. Select **ELECTRICAL INSPECTION** from the main menu.



2. Enter all required information:
 - a. Vin #
 - b. Unit #
 - c. Report Order #

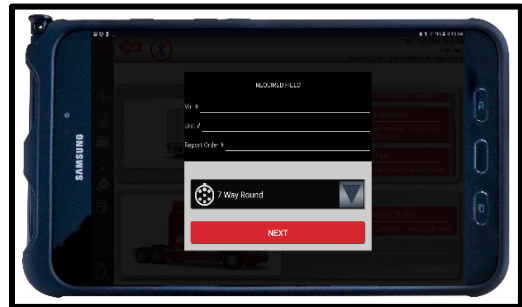

3. Use the drop-down menu to select the configuration you wish to test:
 - 7-Way Round
 - 7-Way Spade
 - Morgan Foreign
 - Morgan Domestic
 - Morgan Foreign w/out M/C
 - Morgan Domestic w/out M/C
 - NATO
 - 6-Way
 - 5-Way
 - 4-Way



4. Press **NEXT** to initiate scan. The app will automatically scan all circuits. Results will appear across each circuit's row in a **PASS/FAIL** designation.



Pass Result

1. If all circuits pass inspection, the app will prompt you to perform a visual walk-around inspection.

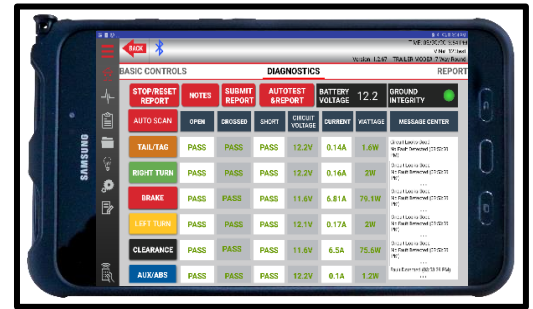

2. Select ALL CIRCUITS ON. Walk around the vehicle to visually ensure all bulbs/lamps are illuminated.
3. Once confirmed, press the PASS switch next to the darkened SUBMIT REPORT button.
4. Once illuminated, press SUBMIT REPORT to finalize.

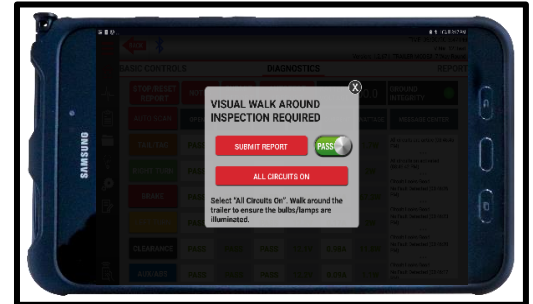

5. All inspections must be signed by the inspector to finalize and save.
6. Press SAVE AND TEST NEW TRAILER if you have more trailers to inspect. Press SAVE AND SHOW REPORT if you are finished and want to view the Electrical Testing results.



7. From the Reports screen, you can view the results, log and view notes or share the report.
8. To share the report, press EMAIL REPORT in the top left corner. A pop-up window will show all the available options on your tablet. Choose your preferred sharing method.
9. Images must be attached to the email separately. Select the attach option in your email browser and chose the desired images that match the report. Images are saved with the following naming mechanism: Category_Section.jpg.

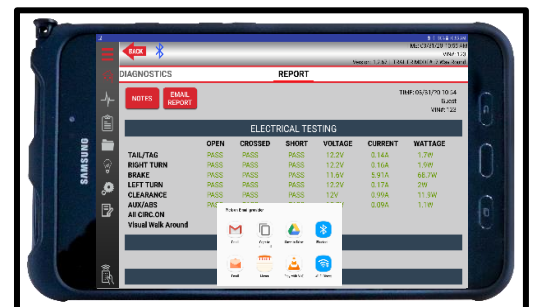

(ex. 1BrakeSystem_AServiceBrake.jpg)

Fail Result

- If some or all circuits fail, the app will prompt you to troubleshoot or finalize the inspection. Once a FAILED result is found, you have four options to proceed:

- A: Troubleshoot the failed circuits.
- B: Save the inspection and test again.
- C: Save and test a new trailer.
- D: Save and show the report.

(Options B-D will require a signature to proceed.)

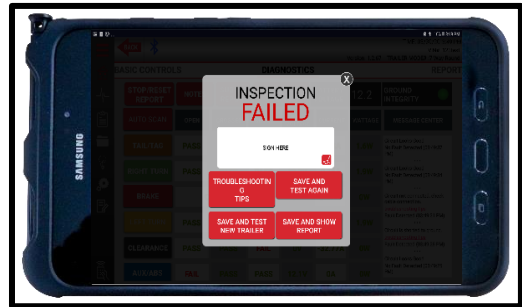

- Press the TROUBLESHOOT TIPS button to view potential issues with the circuits.

Note: Troubleshooting tips can also be accessed through the Message Center at any time during an inspection.

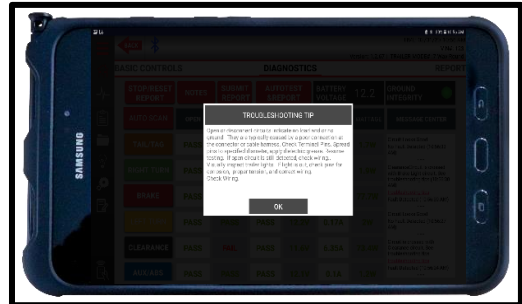

- If possible, fix the issues and retest the circuit in question or all circuits at once until a PASS result is achieved. See PASS RESULT for further steps after PASS has been achieved.

- If you do not fix the issues, you can either press SAVE AND TEST NEW TRAILER if you have more trailers to inspect or press SAVE AND SHOW REPORT if you are finished and want to view the FAILED Electrical Testing results.

- From the Reports screen, you can view the results, log and view notes or share the report.

- To share the report, press EMAIL REPORT in the top left corner. A pop-up window will show all the available options on your tablet. Choose your preferred sharing method.

- Images must be attached to the email separately. Select the attach option in your email browser and chose the desired images that match the report. Images are saved with the following naming mechanism: Category_Section.jpg.

(ex. 1BrakeSystem_AServiceBrake.jpg)

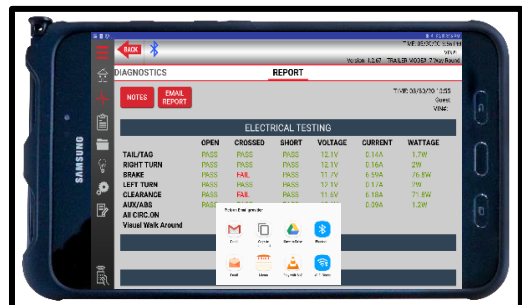
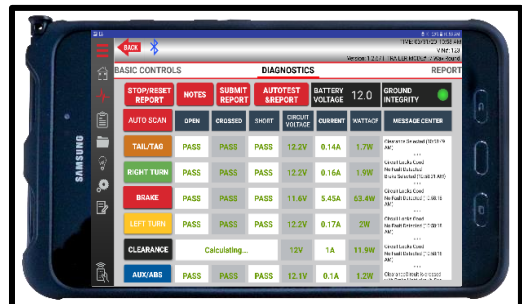

4.5 DOT/PM Inspections

1. With the Alpha MUTT[®] powered on, ensure it is paired with the tablet via Bluetooth[®]. Select DOT/PM INSPECTIONS from the main menu.



2. Turn the desired Test Methods ON or OFF with each toggle switch. Custom Inspections that are created in the Inspection Create tab will be visible only if they are set as DEFAULT in the Inspection Creator section of the app. See Section 7.6 INSPECTION CREATION TAB for more details.
3. Enter UNIT # and REPAIR ORDER #. Inspection cannot begin without this information.
4. Once entered, press BEGIN INSPECTION.



5. Chose VEHICLE TYPE above Vehicle History Record.
6. Create a NEW ACCOUNT by entering all information or select a SAVED ACCOUNT. You can use the search tool to find existing accounts.

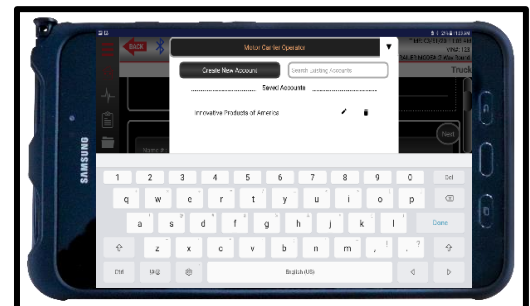

7. Enter VIN #, LOCATION PLATE #, LOCATION, HOURS, HUB READING and OWNER OF VEHICLE as desired.
8. SAVE or CLEAR as needed.
9. To proceed with Inspection, press NEXT or slide left.

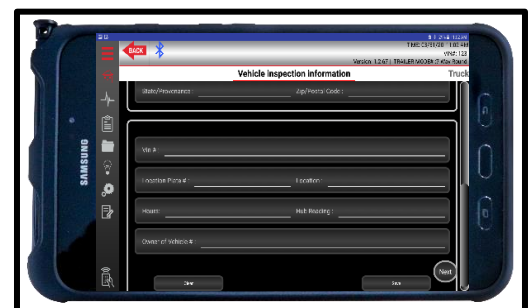

Truck Inspection Controls

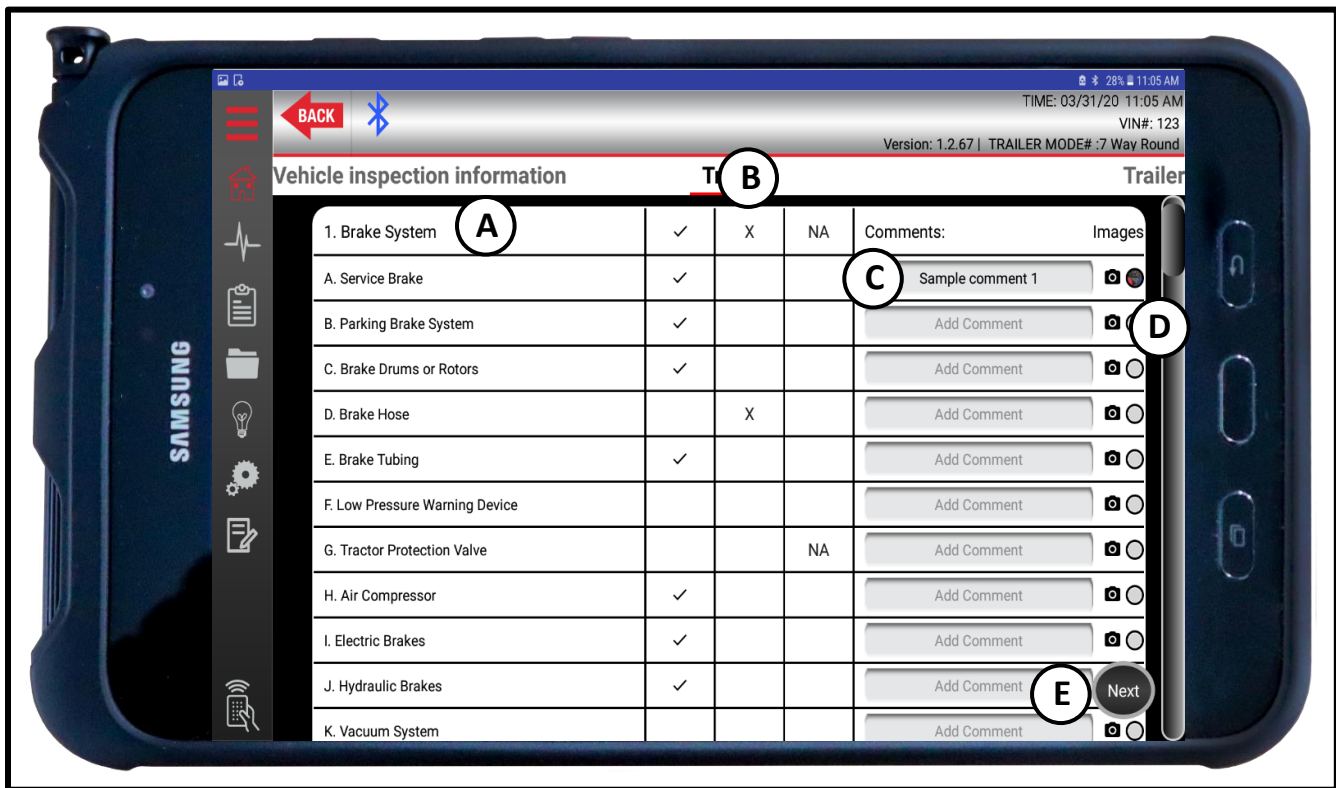

A. Inspection Categories

Standard DOT/PM Inspection categories; editable in Inspection Creation tab.

B. Inspection Results

Standard DOT/PM Inspection-result categories. Press anywhere in box to toggle on/off.

C. Comments

Comments can be added per line by pressing ADD COMMENT and entering desired text in the pop-up window. Comments are saved to the report as SECTION-LINE-COMMENT.

D. Images

Images can be taken with the tablet's camera during inspection or assigned from the tablet's gallery. To take an image, press the CAMERA icon. Once an image is saved to an Inspection, a snapshot can be seen next to the CAMERA icon. Press the snapshot to enlarge for verification. To replace, press the CAMERA icon again and take a new picture. This will overwrite the old image.

E. Next

Move to the next Inspection page (Can also swipe left/right).

Trailer Inspection Controls

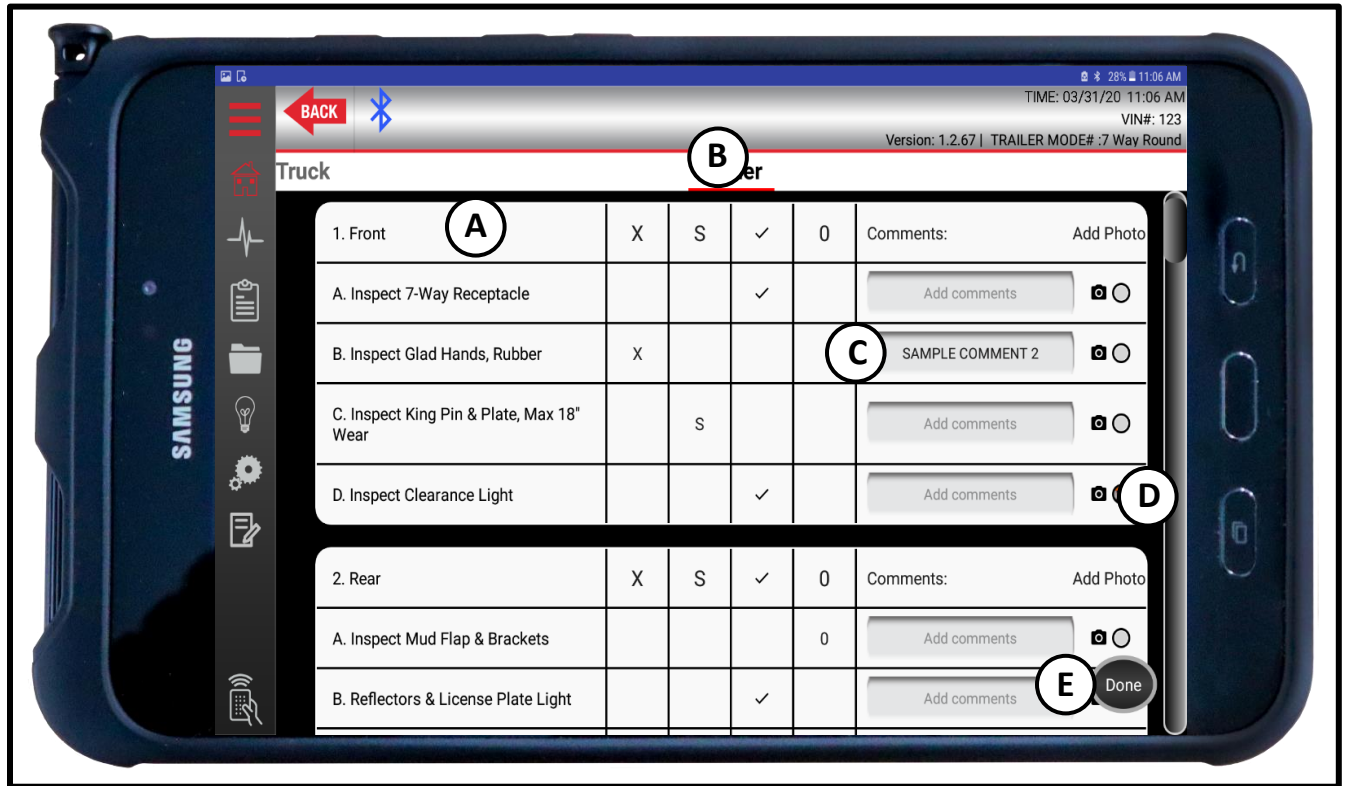

A. Inspection Categories

Standard DOT/PM Inspection categories; editable in Inspection Creation tab.

B. Inspection Results

Standard DOT/PM Inspection-result categories. Press anywhere in box to toggle on/off.

C. Comments

Comments can be added per line by pressing ADD COMMENT and entering desired text in the pop-up window. Comments are saved to the report as CATEGORY-LINE-COMMENT.

D. Images

Images can be taken with the tablet's camera during inspection or assigned from the tablet's gallery. To take an image, press the CAMERA icon. Once an image is saved to an Inspection, a snapshot can be seen next to the CAMERA icon. Press the snapshot to enlarge for verification. To replace, press the CAMERA icon again and take a new picture. This will overwrite the old image.

E. Done

Saves changes and ends Inspection.

4.6 Saved Reports

1. Reports generated through the Alpha MUTT® app can be found in the Reports tab on the left side of the screen.
2. To toggle between Electrical and Inspection Reports, press the button in the bottom right corner.
3. Press VIEW SIGNATURE to see an image of the signature assigned to each report.
4. Press anywhere on the line of the report you wish to view to open the report.



5. Press PRINT to send the report to any available printer.
6. Press PREVIEW to view a printable version of the report.

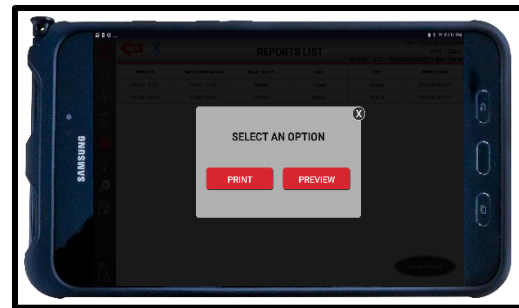

7. To share report from the Reports tab, preview the desired report, then press the three dots icon in the top right corner of the screen and follow the prompts.

NOTE: Report is in an editable state. Be careful to not save unintended edits.

8. Images must be attached to the email separately. Select the attach option in your email browser and chose the desired images that match the report. Images are saved with the following naming mechanism: Category_Section.jpg.

(ex. 1BrakeSystem_AServiceBrake.jpg)

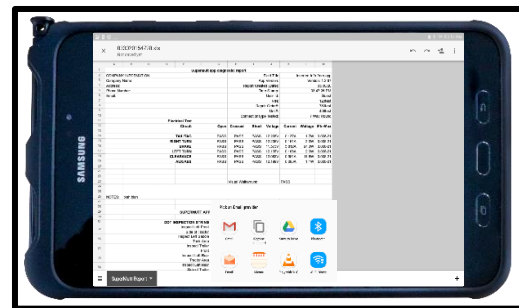

4.7 Inspection Creator Tab

The Alpha MUTT® app allows users to create custom inspections using default templates and select which inspections will appear when initializing an inspection.

1. To begin, select the INSPECTION CREATOR tab from the left side menu.
2. Choose which template to start with.
3. Enter the new template's name. Alternatively, you can import a template from saved files.
4. Press SUBMIT.
5. The new template will appear in the Defaults section. Remember to toggle ON the new template if you wish to use it during inspections.



6. Add or delete lines by entering the Edit mode for each category. Press the EDIT button to begin.
7. Press the PENCIL icon to edit a line.
8. Press the X to delete a line.
9. Use the ADD LINE box to enter new line items.
10. Save each category before moving on to the next.
11. Press ADD CATEGORY at the bottom of the page to create a new category.
12. Press DELETE to delete the template.
13. Press UPDATE to save changes to new template.
14. The new template will now appear as an option in the Test Method when performing DOT/PM Inspections.

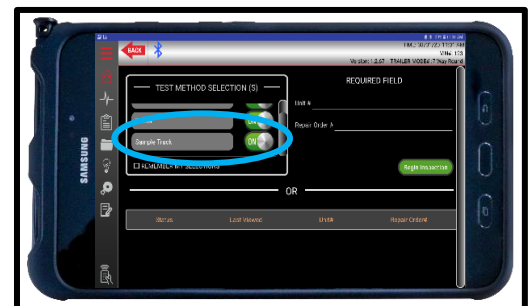
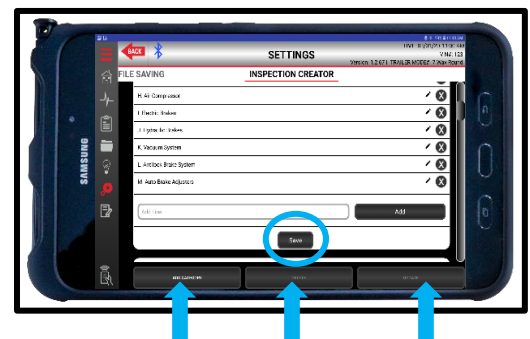

4.8 Sample Reports

		Alpha MUTT® Diagnostic Report									
		(Software allows for user uploaded logos)		Field Title		Inserted Info from app					
Company Name:		IPA		App Version:		Version: 1.2.63					
Address		234 Tinker Street		Report Created:		4/1//2020					
Phone Number:		845-679-4500		Time Stamp:		03:08:48 PM					
Email: tech@ipatools.com				User Id:		Admin					
				VIN:		XXXXXX					
				Repair Order #:		9876					
				Unit #:		1234					
				Connection Type:		7 Way Round					
Electrical Test											
Circuit				Open	Crossed	Short	Voltage	Current	Wattage	Min-Max	
TAIL/TAG		PASS		PASS	PASS	PASS	12.226V	0.137A	1.7W	0.008-21	
RIGHT TURN		PASS		PASS	PASS	PASS	12.206V	0.161A	2.0W	0.008-21	
BRAKE		PASS		PASS	PASS	PASS	11.573V	5.812A	67.3W	0.008-21	
LEFT TURN		PASS		PASS	PASS	PASS	12.165V	0.168A	2.0W	0.008-21	
CLEARANCE		PASS		PASS	PASS	PASS	12.063V	0.981A	11.8W	0.008-21	
AUX/ABS		PASS		PASS	PASS	PASS	12.199V	0.093A	1.1W	0.008-21	
						Visual Walkaround:		PASS			
Notes:											



VEHICLE HISTORY RECORD

UNIT #: 456

REPAIR ORDER # 789

VEHICLE TYPE: Trailer

MOTOR CARRIER OPERATOR

NAME: Innovative Products of America

STREET: 234 Tinker St

CITY, STATE/PROVINCE, ZIP CODE: Woodstock, N.Y., 12498

LICENSE PLATE NUMBER/STATE: 3456JK **LOCATION:** Woodstock

VIN: XXXXXX

HUB READING: 87 **HOURS:** 2

OWNER OF VEHICLE: IPA

QUALIFIED INSPECTORS NAME: Guest **DATE:** 03/31/20 16:30

Status: ✓ = Ok , X = Needs Repair, NA = Not Applicable

	✓	X	NA	Comment	Picture
1. Brake System					
A. Service Brake		✓		✓	✓
B. Parking Brake System	✓				
C. Brake Drums or Rotors	✓				
D. Brake Hose	✓				
E. Brake Tubing	✓				
F. Low Pressure Warning Device	✓				
G. Tractor Protection Valve	✓				
H. Air Compressor	✓				
I. Electric Brakes	✓				
J. Hydraulic Brakes	✓				
K. Vacuum System	✓				
L. Antilock Brake System	✓				
M. Auto Brake Adjusters			✓		
2. Coupling Devices					
A. Fifth Wheels	✓				
B. Pintle Hooks	✓				
C. Drawbar/Towbar Eye	✓				
D. Drawbar/Towbar Tongue	✓				
E. Safety Devices	✓				
F. Saddle-Mounts	✓				
3. Exhaust System					
A. Exhaust system leaking forward or directly below the driver /sleeper compartment	✓				
B. Bus exhaust system leaking or discharging in violation of standard	✓				
C. Exhaust system likely to burn char, or damage the electrical wiring, fuel supply or any combustible part of the motor vehicle	✓				
4. Fuel System					
A. Visible Leak	✓				
B. Fuel Tank Filter Cap Missing	✓				
C. Fuel Tank Securely Attached	✓				
5. Lighting Devices					
A. All lighting devices and reflectors require by Part 393 shall be operable	✓				

6. Safe Loading					
A. Part(S) of vehicle or conditions of loading such that the spare tire or any part of the load damage can fall onto the roadway	✓				
B. Protection against shifting cargo	✓				
C. Container securement devices on intermodal equipment	✓				
7. Steering Mechanism					
A. Steering wheel free play	✓				
B. Steering Column	✓				
C. Front Axle Beam and All Steering Components Other than Steering Column					
D. Steering Gear Box	✓				
E. Pitman Arm	✓				
F. Power Steering	✓				
G. Ball and Socket Joints	✓				
H. Tie Rod and Drag Links	✓				
I. Nuts	✓				
J. Steering System	✓				
8. Suspension					
A. Any U-bolt(s), spring hanger(S), or other axle positioning part(s) cracked, broken, loose or missing resulting in shifting of an axle from its normal position	✓				
B. Spring Assembly	✓				
C. Torque, Radius or Tracking Components	✓				
9. Frame					
A. Frame Members	✓				
B. Tire and Wheel Clearance	✓				
C. Adjustable Axle Assemblies (Sliding Subframes)	✓				
10. Tires					
A. Tires on any steering axle of a power unit	✓				
B. All other tires	✓				
C. Installations of speed-restricted tires unless specifically designated by motor carrier					
11. Wheels and Rims					
A. Lock or Slide Ring	✓				
B. Wheel and Rims	✓				
C. Fasteners	✓				
D. Welds	✓				
12. Windshield Glassing					
Requirement and exceptions as stated pertaining to any crack, discoloration or vision reducing matter (reference 393.60 for exceptions)	✓				
13. Windshield Wipers					
Any power unit that has an inoperative wiper or missing/damaged part that render it ineffective	✓				
14. Motorcoach Seats					
Any passengers seat that is not securely fastened to the vehicle structure.				✓	
Comments					
1. Brake System A. Service Brake (Image 1)					



VEHICLE HISTORY RECORD

UNIT #: 456

REPAIR ORDER # 789

VEHICLE TYPE: Trailer

MOTOR CARRIER OPERATOR

NAME: Innovative Products of America

STREET: 234 Tinker St

CITY, STATE/PROVINCE, ZIP CODE: Woodstock, N.Y., 12498

LICENSE PLATE NUMBER/STATE: 3456 **LOCATION:** Woodstock

VIN: XXXXXX

HUB READING: 87 **HOURS:** 2

OWNER OF VEHICLE: IPA

QUALIFIED INSPECTORS NAME: Guest **DATE:** 03/31/20 16:30

Status ✓ = Checked Ok, X = Unsatisfactory, S = Serviced, O =Out of Service

	X	S	✓	O	Comment	Picture
1. Front			✓			
A. Inspect 7-Way Receptacle			✓			
B. Inspect Glad Hands, Rubber			✓			
C. Inspect King Pin & Plate, Max 18" Wear			✓			
D. Inspect Clearance Light			✓			
2. Rear						
A. Inspect Mud Flap & Brackets			✓			
B. Reflectors & License Plate Light			✓			
C. Reflector Door Hold Backs for All Doors			✓			
D. 2 Red T-light, 2 Red Stop/Turn Lights			✓			
E. 2 Red Clearance Lights			✓			
F. 3 Red ID Lights				✓	✓	
3. General						
A. Inspect & Lubricate Landing Gear	✓				✓	✓
B. Inspect Sand Shoes; Flat			✓			
C. Inspect Bracing for Legs			✓			
4. Sub Frame						
A. Inspect Rails and Crossmembers			✓			
B. Inspect Spring, Hangars, Saddles & U-Bolts			✓			
C. Inspect Wheel Fasteners			✓			
5. Sides			✓			
A. Inspect Market Lights			✓			
B. Inspect Conspicuity Tap			✓			
C. Inspect Bottom & Top Rails, Sheared Rivets			✓			
D. Check Hub Oil Level/Vents on Grease Caps			✓			
6. Identification						
A. Inspect Unit Numbers Front and Rear			✓			
B. Inspect License Plate Match Registration			✓			
C. Inspect Document Box on Trailer Nose			✓			
D. Inspect FHWA Certificate in Document			✓			
7. Underride Support & Bar			✓			
A. Steps, Anti-Slip Dock Bumpers		✓				
8. Inside (if Empty)						
A. Inspect Walls for Kemlite Damage			✓			
B. Inspect Scuff Liner, E-Trac, Pallet Stops			✓			
9. Egress and Ingress						
A. Inspect All Grab Handles, Steps & Platforms			✓			

B. Inspect & Lubricate All Doors, Door Hinges			✓			
C. Lubricate Roll Up Door, Rollers, Hinges & Latch			✓			
10. Brakes						
A. Air Leaks, Valve Operation			✓			
B. Missing/Loose Components			✓			
C. Lubricate Cams & Slack Adjuster Zerks			✓			
D. Adjust Brakes. 1 1/2" Max Travel			✓			
E. Inspect Brake Chamber			✓			
F. Inspect Hoses, Leaks/Cracks/Swelling			✓			
11. Brakes Pad Thickness Min 1/4"						
A. Left Front			✓			
B. Left Rear			✓			
C. Right Front			✓			
D. Right Rear			✓			
12. Tires						
A. Inspect Rims, No Cracks/Elongated			✓			
B. Inspect Tires for Irregular Wear			✓			
C. Inspect Wheel Fasteners			✓			
13. Tread Depth Min 4/32" & Air Pressure			✓			
A. LFO:PSI				32		
B. LFI:PSI				32		
C. LRO:PSI				32		
D. LRI:PSI				32		
E. RFO:PSI				32		
F. RFI:PSI				32		
G. RRO:PSI				32		
H. RRI:PSI				32		
Comments						
2. Rear F. 3 Red ID Lights; 3. General A. Inspect & Lubricate Landing Gear (Image 103)						

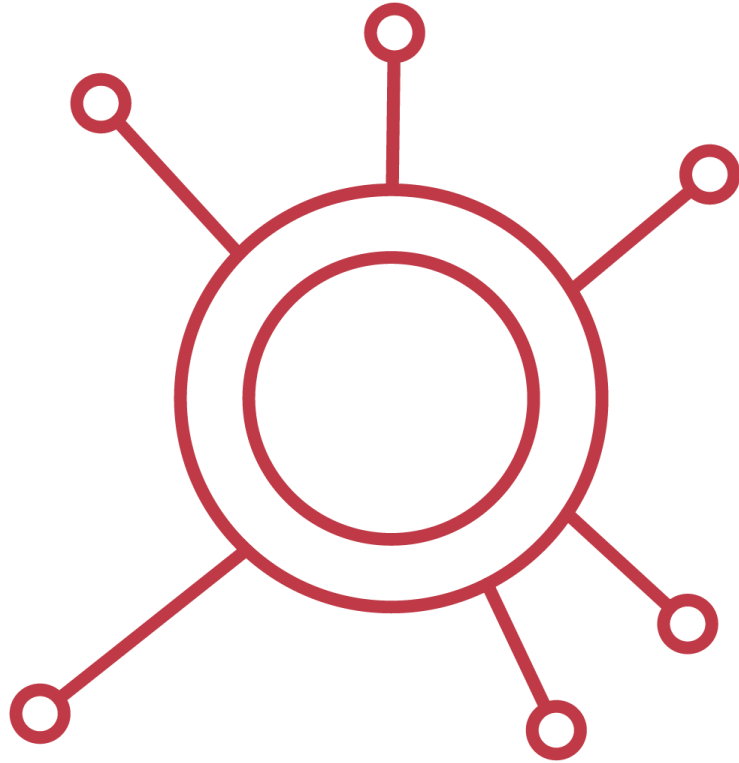

PART 5: TECHNICAL INFORMATION

**This Page Left Blank
on Purpose**

5.1 Exploded Views

Service-Truck Model Body Exploded View

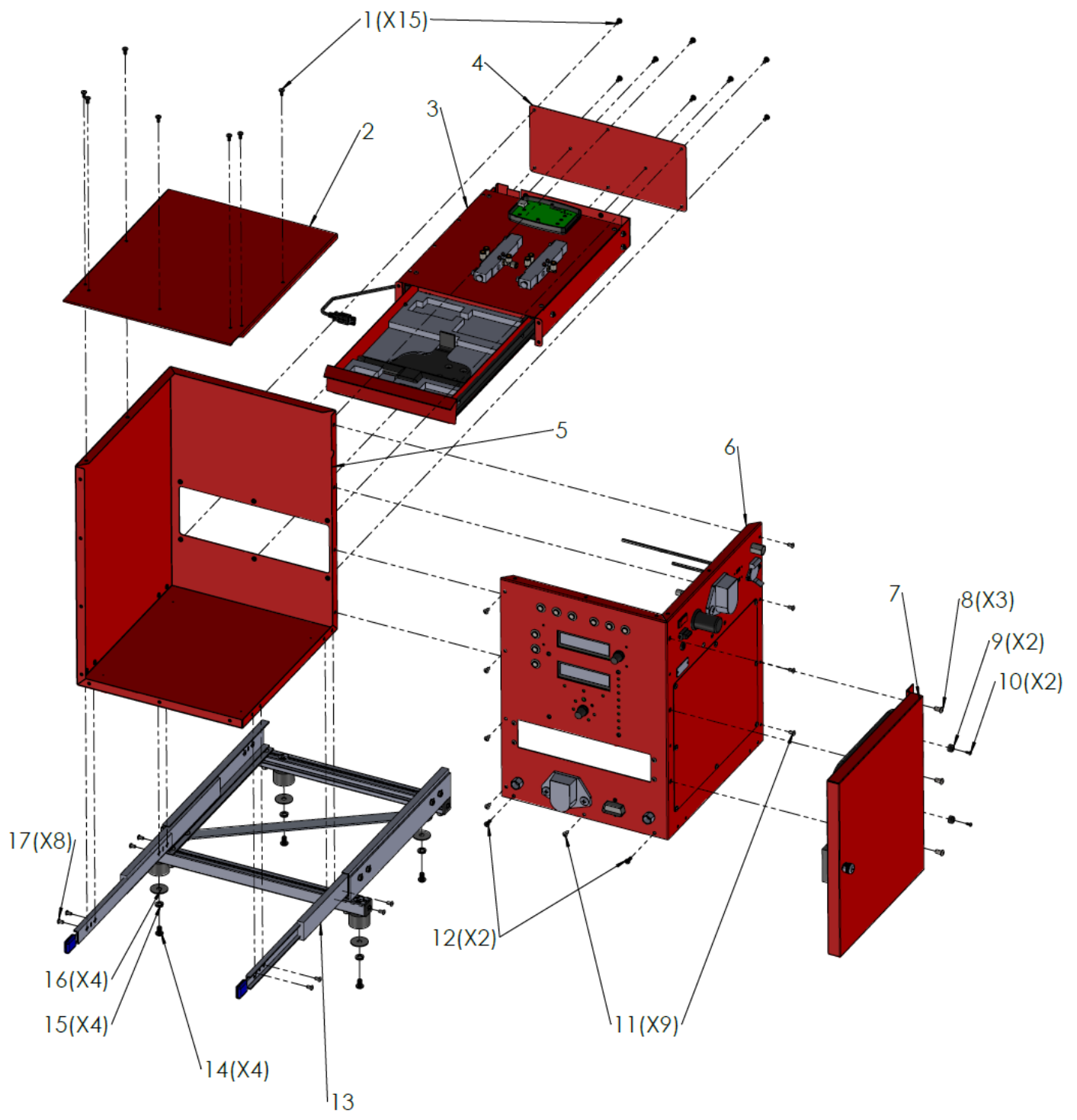

ITEM	PART #	QTY	DESCRIPTION
1	FAS-0150	15	10-32 X 3/8 PHILLIPS
2	005600-3R	1	5600 TOP
3	5600-DRAWER-AS	1	5600 DRAWER
4	005600-11R	1	5600 DRAWER PANEL
5	005600-2R	1	5600 BACK
6	5600-FACE-AS	1	5600 FACE ASSEMBLY
7	5600-DOOR-AS	1	5600 DOOR ASSEMBLY
8	FAS-0036	3	1/4-20 X 3/8 HEX CAP
9	5600-BUMPER	2	DOOR BUMPER
10	FAS-0161	2	#6 X 3/8 SHEET METAL SCREW
11	FAS-0040	9	10-32 X 3/8 HEX CAP
12	7900AP-10	2	5700 EXHAUST FITTING
13	5600-SLDBASE-AS	1	5600 SLIDING BASE
14	FAS-148	4	5/16-18 X 1/2 HEX CAP
15	FAS-0160	4	5/16 SPLIT LOCK WASHER
16	FAS-0159	4	5/16 FENDER WASHER
17	FAS-0143	8	10-32 X 1/2" FLAT HEAD HEX SOCKET

Service-Truck Model Face Exploded View

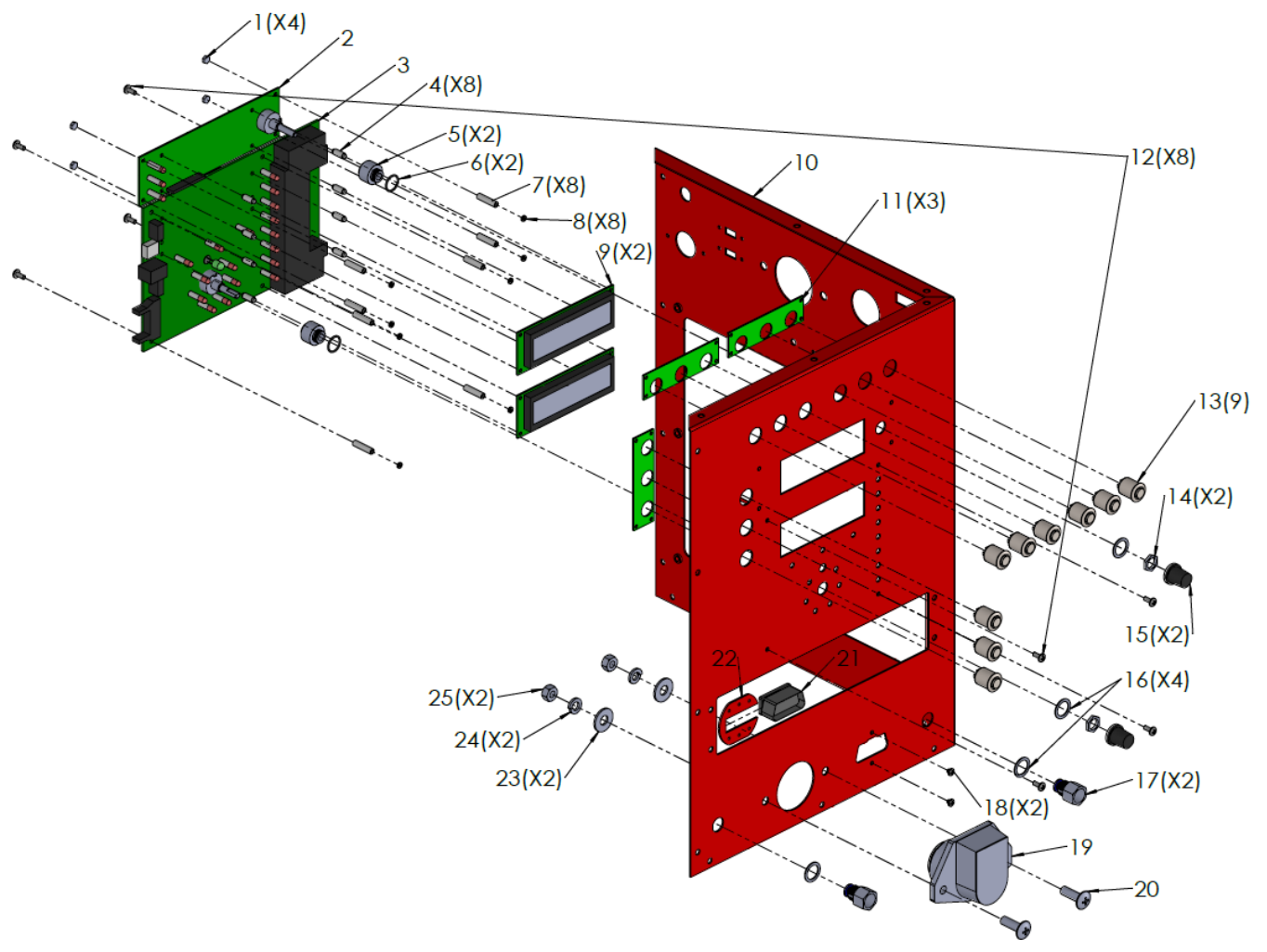

ITEM	PART #	QTY	DESCRIPTION
1	007900K-57	4	4-40 HEX NUT
2	PCB0022-AS2	1	DIGITAL AIR PCB
3	PCB0021-AS2	1	CONTROL BOARD
4	N/A	8	LCD STANDOFF
5	SW0002B	2	LONG ENCODER COLLAR
6	007900K-11B	2	COLLAR O RING
7	N/A	8	NYLON BOARD STANDOFF
8	N/A	8	NYLON WASHER
9	N/A	2	DUAL LINE LCD
10	005600-1R	1	5600 FACE
11	N/A	3	PUSH BUTTON PCB
12	7900K-32A	8	6-32 X 3/8 PHILLIPS
13	PBS-0004GR	9	PUSH BUTTONS
14	SW0002A-JN	2	COLLAR NUT
15	007900K-2	2	ENCODER KNOB
16	N/A	4	14MM FLAT WASHER
17	7900AP-26-AS	2	MILLED AIR BULKHEAD
18	FAS-0125	2	6-32 X 1/8 PHILLIPS
19	7900K-8Z	1	7 WAY ROUND SOCKET
20	7900K-23	2	5/16-18 X 1 PHILLIPS
21	005700-OB2M	1	OB2 MALE SOCKET
22	005700-14R	1	OB2 BRACKET
23	FAS-0009	2	5/16 FLAT WASHER
24	FAS-0008	2	5/16 SPLIT LOCK WASHER
25	FAS-0007	2	5/16-18 HEX NUT

Service-Truck Model Side-Panel Exploded View

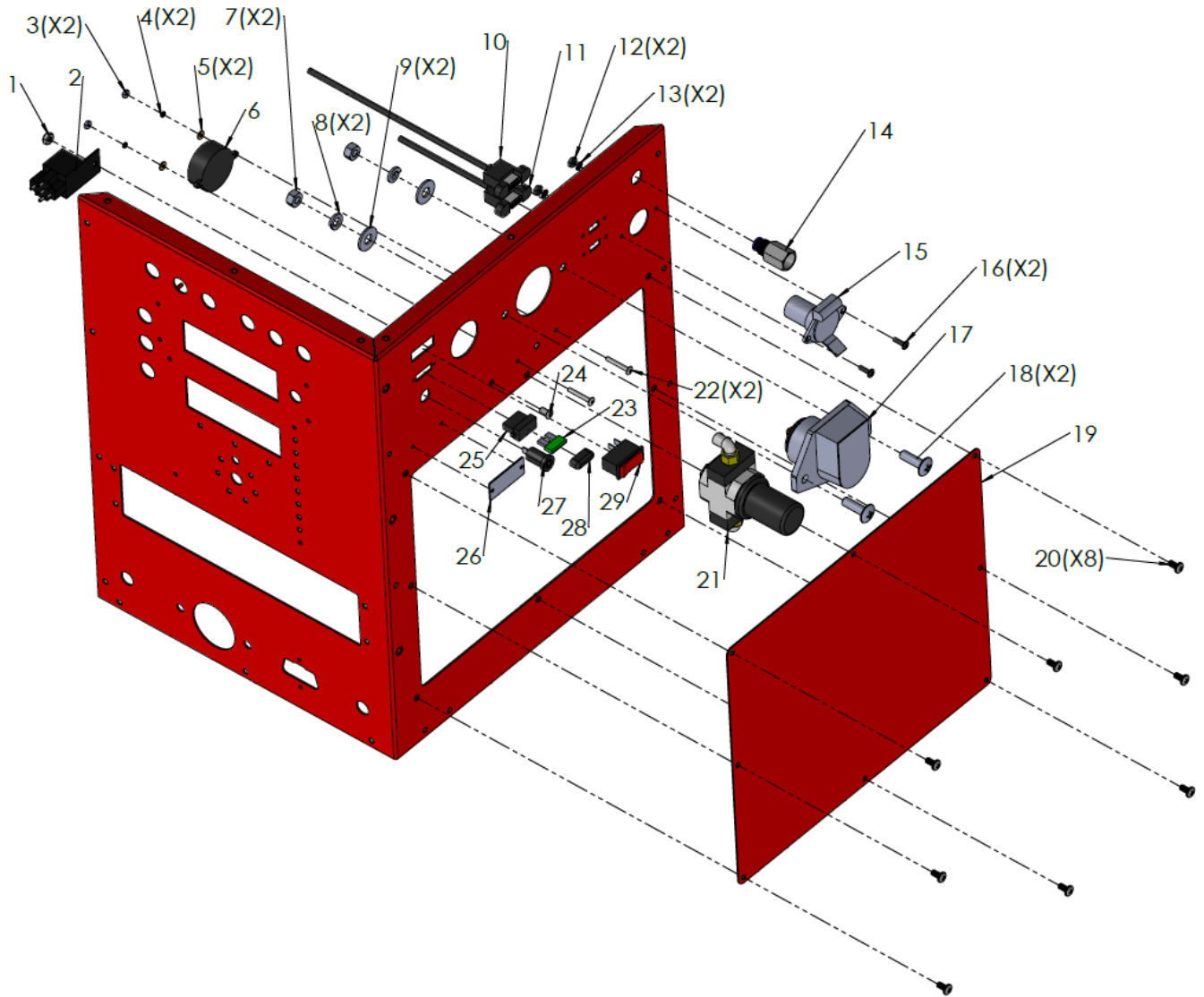

ITEM	PART #	QTY	DESCRIPTION
1	FAS-0144	1	10-32 THIN NYLON LOCKNUT
2	RLY16	1	POWER RELAY
3	7900K-57	2	4-40 NUT
4	7900K-59	2	#4 SPLIT LOCK WASHER
5	7900AP-7	2	#4 FLAT WASHER
6	BUZ-AS2	1	PIEZO
7	FAS-0007	2	5/16-18 NUT
8	FAS-0008	2	5/16 LOCK WASHER
9	FAS-0006	2	5/16 FLAT WASHER
10	CBL-USB3FTMF	1	3' USB CORD
11	CBL-USB18MF	1	18" USB CORD
12	7900K-20	2	6-32 HEX NUT
13	7900K-21	2	#6 EXT TOOTH LOCK WASHER
14	7900AP-26-AS	1	MILLED BULKHEAD ¼" NPT FITTING
15	MUT-EXTPWR2-AS	1	EXT POWER
16	7900K-22	2	6-32 X ½ PHILLIPS
17	9005A-RES-AS	1	7 WAY ROUND RESISTOR PACK
18	7900K-23	2	5/16-18 X 1 PHILLIPS
19	005600-4R	1	ACCESS PANEL
20	FAS-0150	8	10-32 X 3/8 PHILLIPS
21	MUT-REG-AS	1	PRESSURE REGULATOR
22	7900AP-2	2	6-32 X 1 PHILLIPS
23	7900K-85	1	30A FUSE
24	FAS-0040	1	10-32 X 3/8 HEX CAP
25	7900K-18	1	FUSE HOLDER
26	009008-SN	1	ID TAG
27	7900K-13A	1	CHASSIS GROUND
28	7900K-18A	1	FUSE CAP
29	RSW0012-L	1	SEALED POWER SWITCH

Service-Truck Model Storage Drawer Exploded View

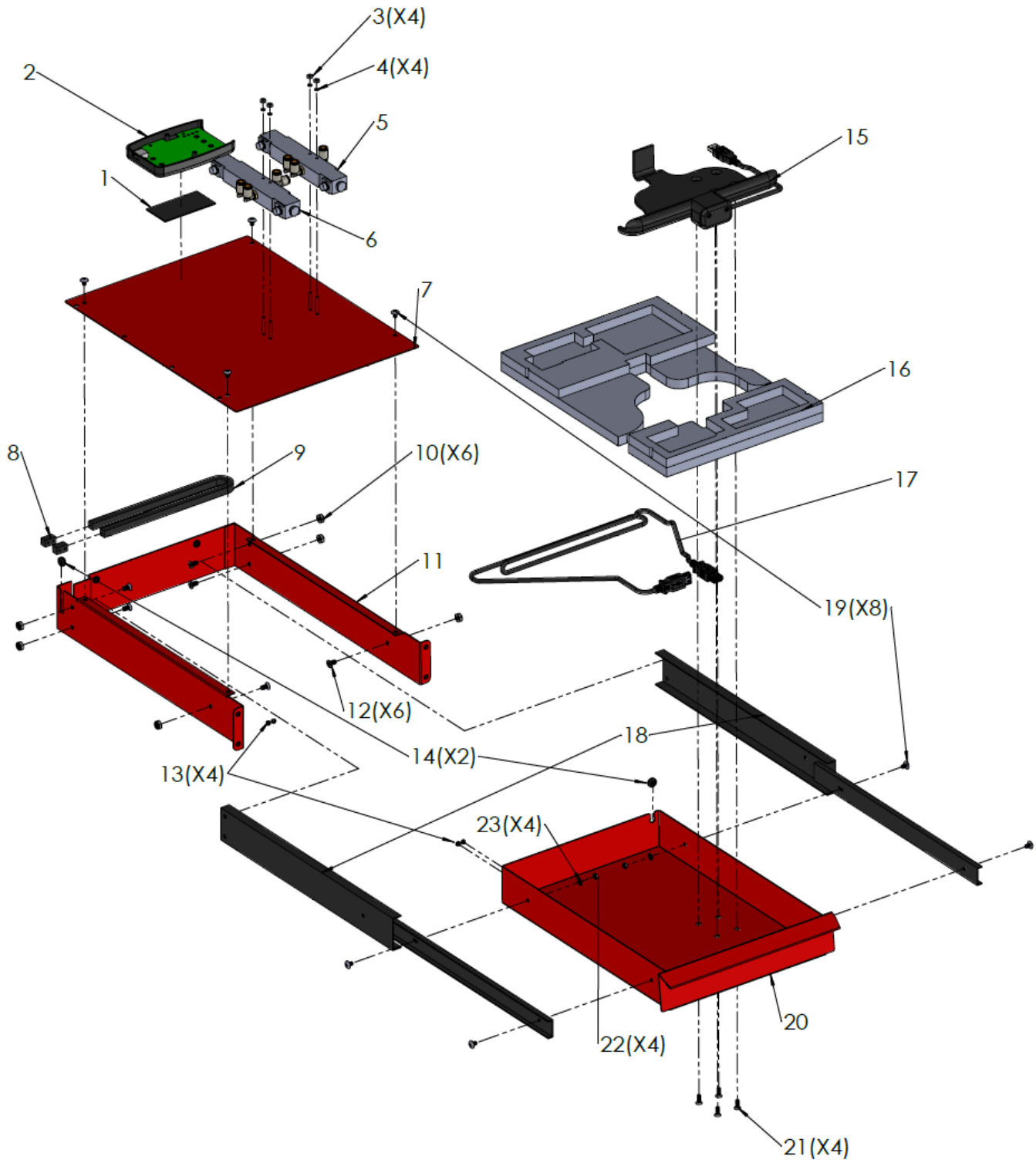

ITEM	PART #	QTY	DESCRIPTION
1	VEL-0004	1	VELCRO STIP
2	5700A-PLCPLT-AS	1	PLC ENCLOSURE ASSEMBLY
3	7900K-57	4	4-40 HEX NUT
4	7900K-59	4	#4 LOCK WASHER
5	MUT-SOLF-AS	1	SOLENOID F AS.
6	MUT-SOLG-AS	1	SOLENOID G AS.
7	005600-8R	1	DRAWER TOP
8	005600-CHAINBRK	1	2PC BRACKET SET
9	005600-CHAIN	1	ECHAIN 24 LINKS
10	FAS-0144	6	10-32 NYON LOCKNUT
11	005600-10R	1	DRAWER FRAME
12	FAS-0143	6	10-32 X 1/2 FLAT HD SOCKET
13	FAS-0162	4	4-40 X 1/8 PHILLIPS
14	005600-GROMMET	2	CABLE GROMMET
15	5700-MNTRT-AS2	1	RAM MOUNT ASSEMBLY WITH CABLE
16	5600-FOAM	1	DRAWER FOAM
17	CBL-USBMF6FT	1	6' USB CABLE
18	005600-SLIDE	1	14" DRAWER SLIDE PAIR
19	FAS-0143	4	8/32 X 1/4 PHILLIPS TRUSS
20	005600-9R	1	DRAWER
21	FAS-0154	4	8/32 X 7/16 FLAT HD PHILLIPS
22	FAS-0151	4	8/32 X 3/32 HEX NUT
23	FAS-0152	4	#8 INT TOOTH LOCK WASHER

Service-Truck Model Door Exploded View

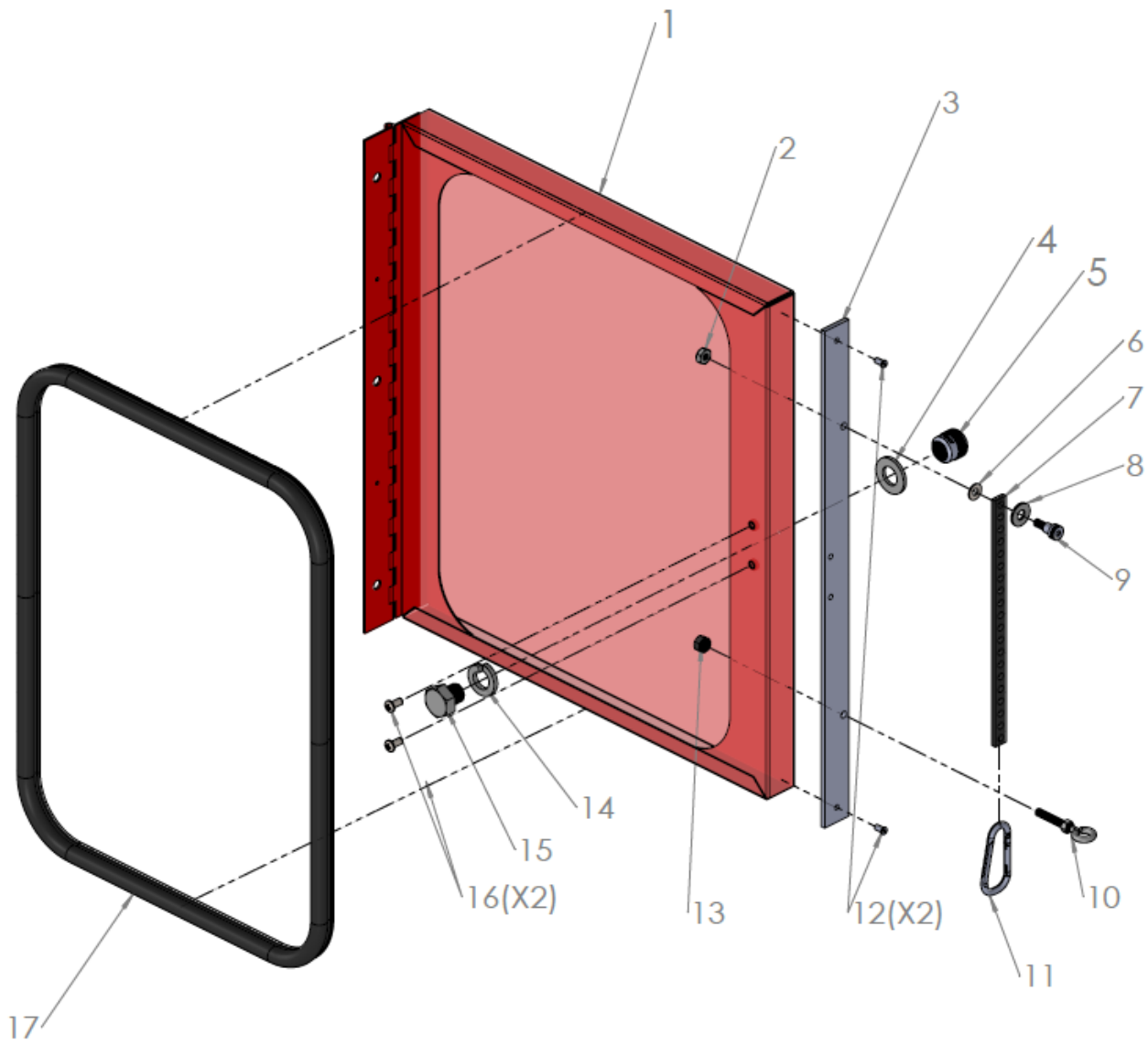

ITEM	PART #	QTY	DESCRIPTION
1	005600-5R	1	5600 DOOR
2	FAS-0144	1	10-32 NYLON LOCK NUT
3	5600-DOORPNL-AS	1	5600 AL DOOR PANEL
4	FAS-0157	1	½" FENDER WASHER
5	7862-3MIL	1	DOORKNOB
6	FAS-0059	1	#10 FLAT WASHER
7	005600-15	1	RUBBER DOOR STRAP
8	FAS-0170	1	¼" FALT WASHER
9	FAS-0050	1	10-32 SHAOULDER SCREW
10	FAS-0169	1	10-24 EYE BOLT & NUT
11	005600-19	1	CARABINER
12	HWR00004	2	1/8" ALUMINUM RIVET
13	FAS-0042	1	10-24 INT TOOTH LOCK WASHER
14	FAS-0156	1	½" LOCK WASHER
15	FAS-0155	1	½"-20 X ½" HEX BOLT
16	FAS-0020	2	8-32 X 3/8 HEX SOCKET
17	5600-TRIMCUT50	1	CUT TRIM SEAL

Service-Truck Model Slide-Out Tray Exploded View

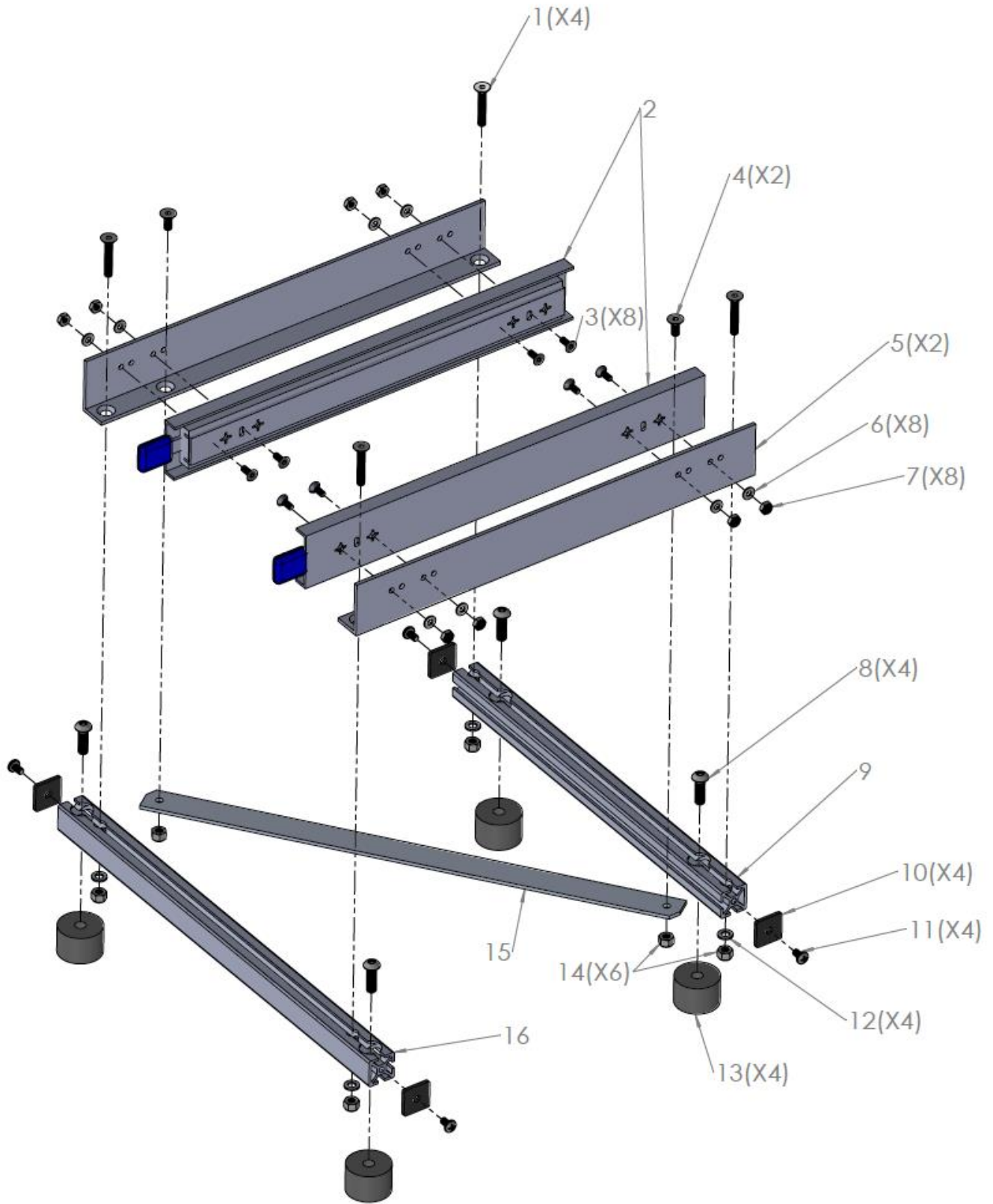

ITEM	PART #	QTY	DESCRIPTION
1	FAS-0140	4	¼-20 X 1-1/2" FLAT HEAD
2	005600-SLIDE2	1	16" UNIT SLIDE PAIR
3	FAS-0143	8	10-32 X ½" FLAT HEAD HEX SOCKET
4	FAS-0146	2	¼-20 X 5/8" FLAT HEAD HEX SOCKET
5	ALU00016-MIL	2	ANGLE BRACKET
6	FAS-0145	8	#10 WASHER SS
7	FAS-0144	8	10-32 NYLON LOCK NUT
8	FAS-0141	4	5/16-18 X 1" ROUND HEAD HEX SOCKET
9	ALU0002-15MIL	1	REAR BRACE
10	9066-4	4	PLASTIC END CAPS
11	FAS-0142	4	12-24 X 3/8" PHILLIPS ROUND
12	FAS-0045	4	¼" WASHER
13	RBF0002	4	Ø 1.5" X 1" FEMALE THREAD RUBBER FEET
14	FAS-0027	6	¼" NYLON LOCK WASHER
15	ALU00017-MIL	1	CROSS BRACE
16	ALU0002-17MIL	1	FRONT BRACE

5.2 Typical Trailer Wiring

The standard wirings pictured below are viewed from both the front of the socket and the plug. Not all trailers/vehicles are wired to these standards. The use of an electrical circuit tester is necessary to ensure proper match of vehicle's wiring to trailer's wiring. On some trailers with 6-way round plugs, the 12V wire and electric brake wire may be reversed (particularly horse trailers).

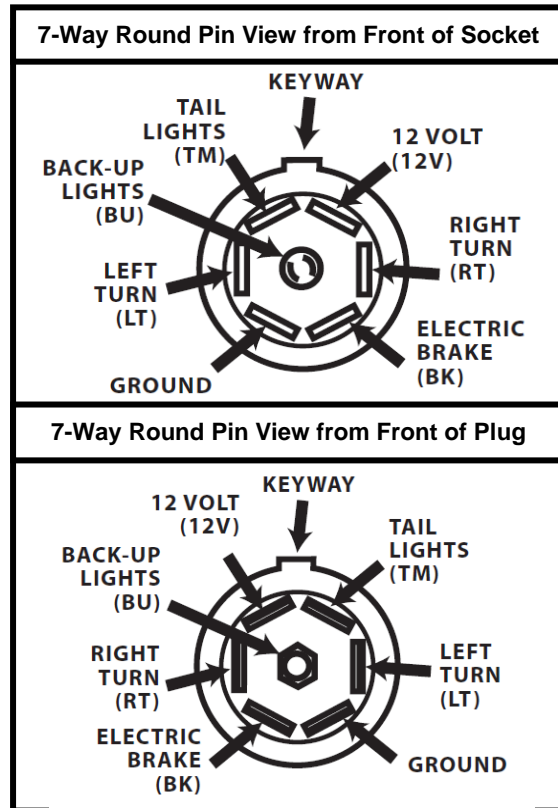
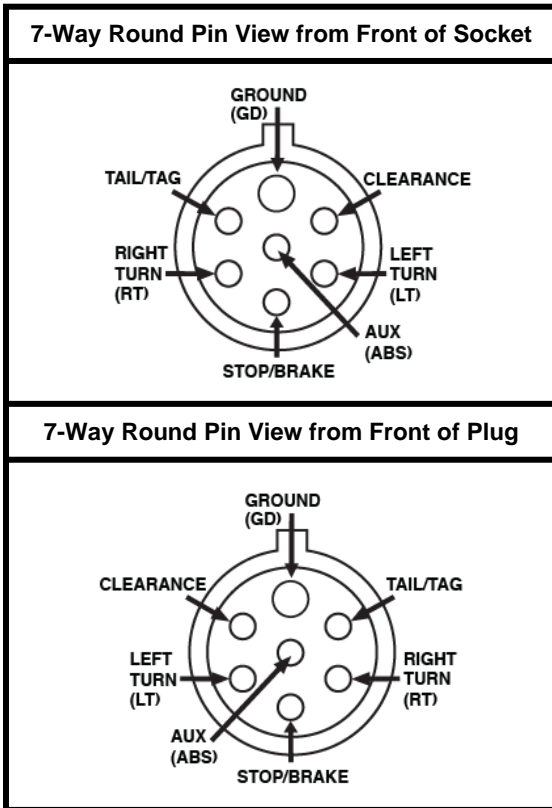
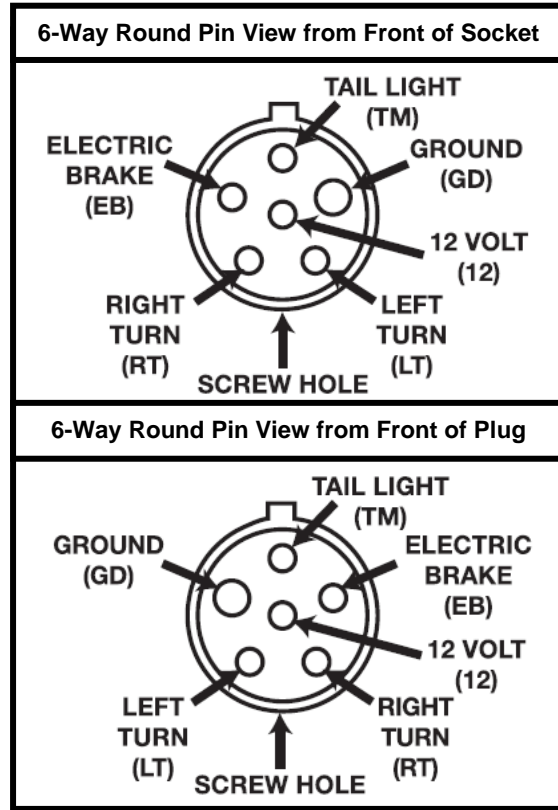
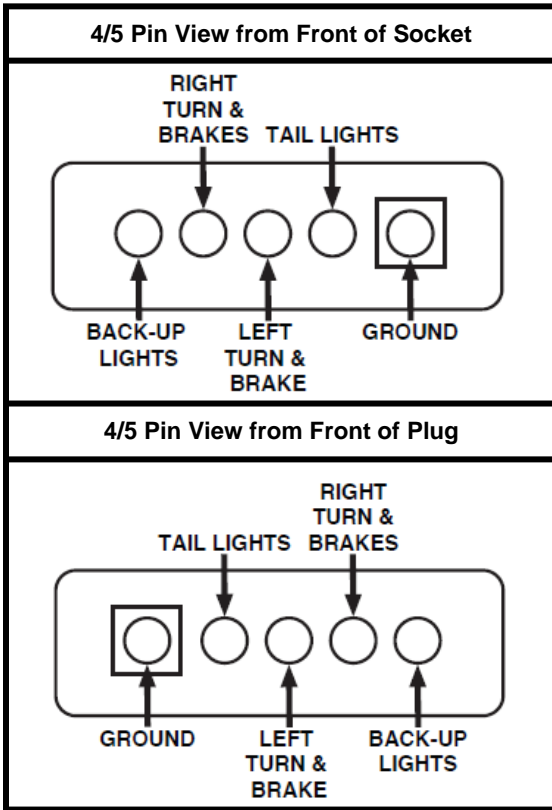

5.3 Complete Specifications

#5610A Alpha MUTT® (2nd Gen) with ABS Service-Truck Model

Specifications

- 7-Way Round Pin Connection Type
- 12/24V DC Power Input
- 20A @ 12/24V DC Source Output
- 120 psi Max. Operating Pressure

Technology

- 4.0 Bluetooth®
- High-Speed Microprocessor
- 1mA Resolution Ammeter
- (2) Dual-Line,32-Character, All Environment Digital LCD Screens
 - Backlit, Sunlight-Readable, Wide-Angle View
 - Upper Designated Air Pressure Testing
 - Lower Designated Voltage, Current, ABS, and Settings Menu

Mounted Equipment

- 16ga. Powder-Coated Steel Construction
- Waterproof, Sealed Faceplate
- Illuminated Stainless Steel Pushbutton Switches
- Steel 7-Way Socket
- Panel-Mounted Regulator
 - 0-125 PSI
- Integrated ¼" NPT Stone Air Filter
- Weather-Proof Steel Door
- Integrated Soft-Close Storage Drawer
- Vibration-Dampening Rubber Mounts
- Stainless Steel Hardware Pack

Ports

- 12V Socket
- Two-Pin External Power Input Socket
- OBD2 Bluetooth® Port
- 30-Amp Fuse Holder w/ Fuse
- (2) USB Data Ports
 - PLC Firmware Updates
 - PCB Firmware Updates
- Chassis Ground

Weight and Dimensions

- 15.5" W x 19.5" H x 17" D
- 46 lbs.

Warranty

- 3-Year Limited
- Free Lifetime Technical Support and Video Conference

#5610A-RT8 Alpha MUTT® (2nd Gen) with ABS and Rugged Tablet Service-Truck Model

Specifications

- 7-Way Round Pin Connection Type
- 12/24V DC Power Input
- 20A @ 12/24V DC Source Output
- 120 psi Max. Operating Pressure

Technology

- 8" Military-Grade, Rugged Tablet
- IPA® Productivity Suite
- 4.0 Bluetooth®
- High-Speed Microprocessor
- 1mA Resolution Ammeter
- (2) Dual-Line,32-Character, All Environment Digital LCD Screens
 - Backlit, Sunlight-Readable, Wide-Angle View
 - Upper Designated Air Pressure Testing
 - Lower Designated Voltage, Current, ABS, and Settings Menu

Mounted Equipment

- 16ga. Powder-Coated Steel Construction
- Waterproof, Sealed Faceplate
- Illuminated Stainless Steel Pushbutton Switches
- Steel 7-Way Socket
- Panel-Mounted Regulator
 - 0-125 PSI
- Integrated ¼" NPT Stone Air Filter
- Weather-Proof Steel Door
- Integrated Soft-Close Storage Drawer
 - w/ Tablet Docking/Charging Station and Customer Foam Cutouts for Remote Control and Bluetooth® Module
- Vibration-Dampening Rubber Mounts
- Stainless Steel Hardware Pack

Ports

- 12V Socket
- Two-Pin External Power Input Socket
- OBD2 Bluetooth® Port
- 30-Amp Fuse Holder w/ Fuse
- (2) USB Data Ports
 - PLC Firmware Updates
 - PCB Firmware Updates
- Chassis Ground

Weight and Dimensions

- 15.5" W x 19.5" H x 17" D
- 48 lbs.

(Continued...)

Warranty

- 3-Year Limited
- Free Lifetime Technical Support and Video Conference

#5611A Alpha MUTT® (2nd Gen) with ABS and Slide-Out Base Service-Truck Model

Specifications

- 7-Way Round Pin Connection Type
- 12/24V DC Power Input
- 20A @ 12/24V DC Source Output
- 120 psi Max. Operating Pressure

Technology

- 4.0 Bluetooth®
- High-Speed Microprocessor
- 1mA Resolution Ammeter
- (2) Dual-Line,32-Character, All Environment Digital LCD Screens
 - Backlit, Sunlight-Readable, Wide-Angle View
 - Upper Designated Air Pressure Testing
 - Lower Designated Voltage, Current, ABS, and Settings Menu

Mounted Equipment

- 16ga. Powder-Coated Steel Construction
- Waterproof, Sealed Faceplate
- Illuminated Stainless Steel Pushbutton Switches
- Steel 7-Way Socket
- Panel-Mounted Regulator
 - 0-125 PSI
- Integrated ¼" NPT Stone Air Filter
- Weather-Proof Steel Door
- Integrated Soft-Close Storage Drawer
- Removable, Sliding-Base Service Tray
- Vibration-Dampening Rubber Mounts
- Stainless Steel Hardware Pack

Ports

- 12V Socket
- Two-Pin External Power Input Socket
- OBD2 Bluetooth® Port
- 30-Amp Fuse Holder w/ Fuse
- (2) USB Data Ports
 - PLC Firmware Updates
 - PCB Firmware Updates
- Chassis Ground

(Continued...)

Weight and Dimensions

- 16.5" W x 21.5" H x 19" D (33" Extended)
- 54 lbs.

Warranty

- 3-Year Limited
- Free Lifetime Technical Support and Video Conference

#5611A-RT8 Alpha MUTT® (2nd Gen) with ABS, Rugged Tablet and Slide-Out Base Service-Truck Model

Specifications

- 7-Way Round Pin Connection Type
- 12/24V DC Power Input
- 20A @ 12/24V DC Source Output
- 120 psi Max. Operating Pressure

Technology

- 8" Military-Grade, Rugged Tablet
- IPA® Productivity Suite
- 4.0 Bluetooth®
- High-Speed Microprocessor
- 1mA Resolution Ammeter
- (2) Dual-Line,32-Character, All Environment Digital LCD Screens
 - Backlit, Sunlight-Readable, Wide-Angle View
 - Upper Designated Air Pressure Testing
 - Lower Designated Voltage, Current, ABS, and Settings Menu

Mounted Equipment

- 16ga. Powder-Coated Steel Construction
- Waterproof, Sealed Faceplate
- Illuminated Stainless Steel Pushbutton Switches
- Steel 7-Way Socket
- Panel-Mounted Regulator
 - 0-125 PSI
- Integrated ¼" NPT Stone Air Filter
- Weather-Proof Steel Door
- Integrated Soft-Close Storage Drawer
 - w/ Tablet Docking/Charging Station and Customer Foam Cutouts for Remote Control and Bluetooth® Module
- Removable, Sliding-Base Service Tray
- Vibration-Dampening Rubber Mounts
- Stainless Steel Hardware Pack

Ports

- 12V Socket
- Two-Pin External Power Input Socket

(Continued...)

- OBD2 Bluetooth® Port
- 30-Amp Fuse Holder w/ Fuse
- (2) USB Data Ports
 - PLC Firmware Updates
 - PCB Firmware Updates
- Chassis Ground

Weight and Dimensions

- 16.5" W x 21.5" H x 19" D (33" Extended)
- 56 lbs.

Warranty

- 3-Year Limited
- Free Lifetime Technical Support and Video Conference

#5700-TABRT-AS Military-Grade, Rugged Tablet

Specifications

- Android 7.1 Operating System
- 8.0" Wet/Glove Touch Screen
- WXGA (1280 x 800) Display Resolution
- 16GB (Internal) Micro SD Memory (up to 256GB)
- Pogo Pin Connection for Wireless, Quick Charge
- Built-in Stylus
- V.4.2 Bluetooth®
- Li-Polymer Battery (Replaceable) with Up to 11 hrs. Life
- Face Recognition, Accelerometer, Fingerprint, Gyro, Geomagnetic, Hall, RGB Light, and Proximity Sensors
- IP68 (Water and Dust Resistant)
- Anti-Shock (Drop from 1.2m Height with Cover)
- MIL-STD-810G, EPEAT, Energy Star, TCO and RoHS Certified