



# HEAT STORM

# User manual

**Model: A-1500-PHX & PHXG**

1500 W | Forced air

Quartz infrared element





# Table of contents:

Important instructions .....	4
Installation instructions .....	7
Operations & controls .....	11
Maintenance.....	14
Troubleshooting guide.....	16
Return policy .....	18
1-year limited warranty.....	18

Thank you and congratulations on your Heat Storm Infrared Heater! **Please read and keep all safety and use instructions.** Should you have any questions or concerns, please don't hesitate to reach out to us at 435-752-6611 or [cs@heatstorm.com](mailto:cs@heatstorm.com).

## SPECIFICATIONS

Wattage: 1500	LxWxH: 19 x 4 x 13 inches
Amps: 12.5/6.25	Weight: 8.5 lbs
BTU: 5200	Decibels: 44-47
Voltage: 120	Cord length: 3 ft
CFM: 48	Heat settings: 2
Square footage: 150-750 ft <sup>2</sup>	Heating: Forced air, Quartz infrared element

# Important instructions

Please read and understand this entire manual before attempting to assemble, operate, or install the product. Use this heater only as described in the manual. If the directions are not followed, an electric shock or fire may result causing property damage, personal injury or death.

## SAFETY GUIDELINES

- Adhere to basic precautions to minimize the risk of fire, electric shock, and injury when using electrical appliances.
- The heater becomes hot during operation; avoid direct contact with hot surfaces to prevent burns.
- Exercise extreme caution in the presence of children, invalids, or when the appliance is unattended. Children should not play with the appliance.
- Individuals with reduced capabilities should not operate the appliance without supervision or proper instruction.
- Unplug the heater when not in use for an extended period.
- The heater includes a thermostat limiter. If the inner temperature overheats or abnormal heating occurs, power will be cut off to prevent the risk of fire or heater damage.

## WARNING

- For any maintenance other than filter maintenance, please contact an authorized service representative.
- High temperature, risk of fire, keep electrical cords, drapery, furnishings, and other combustibles at least 3 feet (0.9 m) from the front of the heater and away from the side and rear. To reduce the risk of fire, do not store or use gasoline or other flammable vapors and liquids in the vicinity of the heater.
- Heat Storm Infrared Heaters are considered to be an appliance. Each heater and appliance should be on its own circuit.
- DO NOT operate if the following occurs:
  - » Heater has a damaged cord or plug.
  - » After the heater malfunctions.
  - » Heater has been dropped or damaged in any manner.Turn off the heater, disconnect the cord, and have heater inspected/serviced by an electrician before reusing or discard the heater.

## CAUTION

- To prevent electric shock, match the wide blade of the plug to the wide slot and fully insert.
- To disconnect, turn controls off, wait for the fan to stop, and then remove the plug.
- Do not insert foreign objects into ventilation or exhaust openings to prevent electric shock, fire, or heater damage.
- Do not block air intakes or exhaust.
- Under no circumstances should this heater be modified. Modifications will void the warranty. Parts removed for servicing must be replaced prior to operation.
- Do not move the heater while it is operating. Turn off the heater, wait for the fan to stop completely, and then relocate.
- Plug the heater directly into a wall outlet; do not use extension cords, surge protectors, or relocatable power taps. This heater is designed for standard 120-volt outlets and should only be connected to a proper 2-prong polarized outlet.
- Ensure the cord is not under carpeting, covered with rugs, runners, or similar coverings. Avoid routing it under furniture or appliances and position it away from high-traffic areas to prevent tripping hazards.
- If the supply cord is damaged, it must be replaced by the manufacturer, its service agent, or similarly qualified persons in order to avoid a hazard.
- Do not use in the following areas: outdoors, closets, or locations with gasoline, paint, or flammable liquids.
- This product contains a lithium button/coin cell battery. If a new or used lithium button/coin cell battery is swallowed or enters the body, it can cause severe internal burns and can lead to death in as little as 2 hours. Always completely secure the battery compartment. If the battery in the compartment does not close securely, stop using the product, remove the batteries, and keep it away from children. If you think batteries have been swallowed or placed inside any part of the body, seek immediate medical attention.
- Remove and immediately recycle or dispose of used batteries according to local regulations and keep them away from children. Do NOT dispose of batteries in household trash or incinerate.
- Even used batteries may cause severe injury or death.
- Call a local poison control centre for treatment information.
- Battery type Li-Mn CR2025 3.0V
- Non-rechargeable batteries are not to be recharged.

- Do not force discharge, recharge, disassemble, or heat above 60°C (specified temperature rating) or incinerate. Doing so may result in injury due to venting. Leakage or explosion resulting in chemical burns.
- Ensure the batteries are installed correctly according to polarity (+ and -).
- Do not mix old and new batteries, different brands or types of batteries, such as alkaline, carbon-zinc, or rechargeable batteries.
- Remove and immediately recycle or dispose of batteries from equipment not used for an extended period of time according to local regulations.
- Always completely secure the battery compartment. If the battery compartment does not close securely. Stop using the product, remove the batteries, and keep them away from children.
- Hyperthermia can result in death. Symptoms of hyperthermia include high body temperature, headache, nausea, vomiting, tiredness, dizziness, fainting, and rapid pulse. If you begin to experience symptoms related to hyperthermia, turn off the heater and seek medical attention.
- To avoid excessive room temperatures which can cause hyperthermia: DO NOT leave product running unattended in a confined space around infants, or individuals with reduced physical, sensory, or mental capabilities.

## **! WARNING**

- **INGESTION HAZARD:** This product contains a button cell or coin battery.
- **DEATH** or serious injury can occur if ingested.
- A swallowed button cell or coin battery can cause **Internal Chemical Burns** in as little as **2 hours**.
- KEEP new and used batteries **OUT OF REACH OF CHILDREN**
- **Seek immediate medical attention** if a battery is suspected to be swallowed or ingested inside any part of the body.



# Installation instructions

## HEATER LOCATION

When choosing a location for your new heater, ensure that the general instructions are followed. Your heater must have the feet installed or be wall mounted prior to operation. Do not prop the heater up against objects or use the heater with the grill placed vertically. For best effect, install the heater out of direct sunlight.

### **Basement or garage use**

The heater can be utilized in a finished basement with drywall and carpet. For other scenarios, consider Heat Storm Outdoor Infrared Heaters. Visit [heatstorm.com](http://heatstorm.com) for details.

### **Vaulted or cathedral ceilings**

The heater can be used with vaulted or cathedral ceilings. However, initial room heating may take longer. Once the desired temperature is reached, the heater will cycle accordingly.

### **Poorly insulated areas**

Note that rooms with poor insulation may not retain heat efficiently, potentially leading to longer or more frequent operation.

### **Cold climate installation note**

Placing the unit under a window or on a poorly insulated wall may result in the heater reading a colder ambient temperature than the actual room temperature.

### **Heating multiple rooms**

Effectiveness depends on floor plan openness and room sizes. Experiment to find the most suitable configuration.

*NOTE: Designed for supplemental heating in spaces from 150 to 750 square feet.*

### **DO NOT USE in the following areas:**

- Outdoors - use Heat Storm Outdoor Infrared Heaters
- Locations with gasoline, paint, or flammable liquids
- Wet or moist locations
- Closets

## POWER CONNECTION GUIDELINES

Heat Storm Infrared Heaters are considered to be an appliance. Each heater and appliance should be on its own circuit.

Plug the heater directly into a wall outlet; do not use extension cords, surge protectors, or relocatable power taps. This heater is designed for standard 120-volt outlets and should only be connected to a proper 2-prong polarized outlet.

Ensure the cord is not under carpeting, covered with rugs, runners, or similar coverings. Avoid routing it under furniture or appliances and position it away from high-traffic areas to prevent tripping hazards.



### CAUTION

High temperature, risk of fire, keep electrical cords, drapery, furnishings, and other combustibles at least 3 feet (0.9 m) from the front of the heater and away from the side and rear. To reduce the risk of fire, do not store or use gasoline or other flammable vapors and liquids in the vicinity of the heater.

## TOOLS NEEDED FOR INSTALLATION

- 3/16" drill bit
- Philips screwdriver

*Missing parts? Email us at [cs@heatstorm.com](mailto:cs@heatstorm.com)*

## FEET INSTALLATION

- 1** Attach two feet peices to a connector plate. Secure it to the heater with two wingnut screws. Repeat.

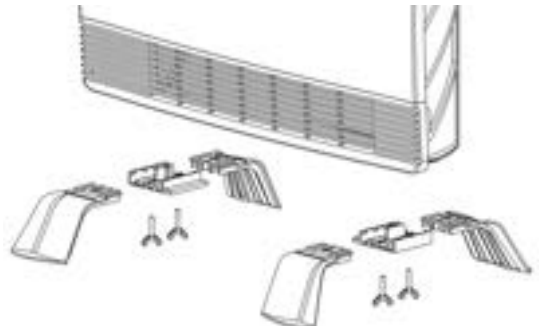

# WALL INSTALLATION

- 1** Select a suitable wall for your heater, ensuring there is at least a 4½-inch clearance between the heater and the nearby walls, ceiling, and floor. Additionally, place the heater in a location where the cord can reach an outlet for power.

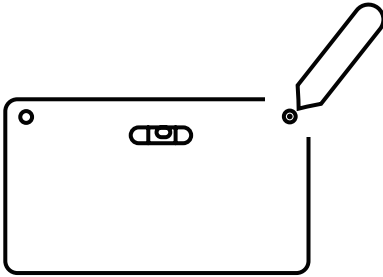
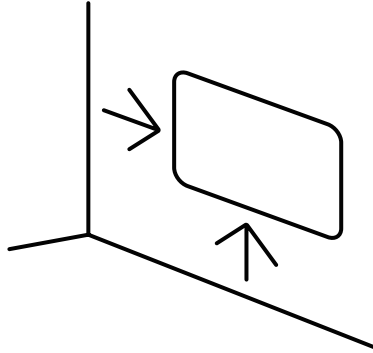

- 2** Use the drilling guide and a pencil to MARK the guide holes.

- 3** Drill holes using the 3/16" drill bit and insert the drywall anchors into the holes.

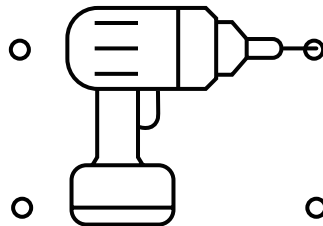

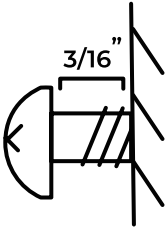

- 4** Begin by inserting the top two screws, leaving a  $3/16$ " gap to the wall

- 5** Hang the heater onto the top two screws

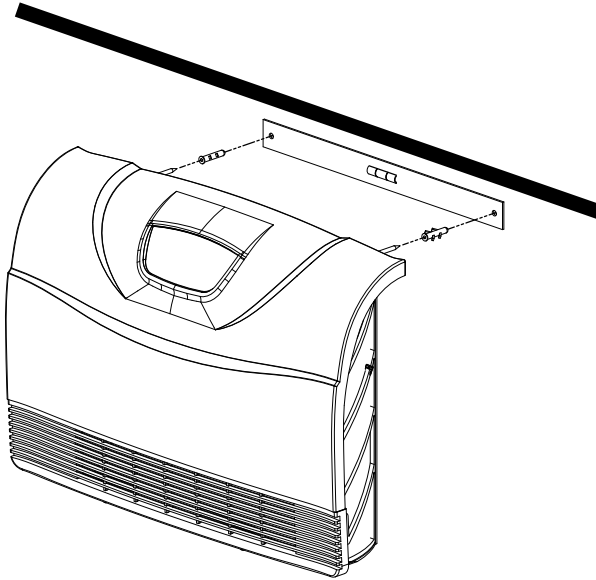

# Operations & controls

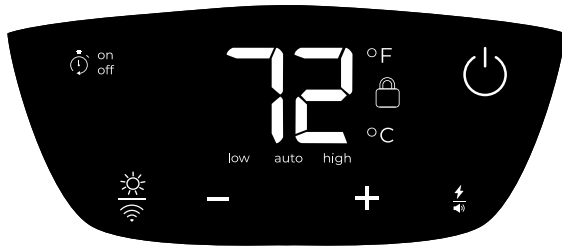

## **Power ON/OFF**

Press the power icon to alternate between on and off.

## **Child lock**

Press and hold the power icon for 5 seconds to engage/disengage child lock. When the child lock is on a red lock icon will appear and no changes can be made to the settings until the child lock is turned off.

*NOTE: The child lock feature can only be activated using the control panel on the heater; it is not accessible through the remote control.*

## **Thermostat calibration**

Thermostat readings may fluctuate depending on the surroundings. You can manually calibrate the thermostat on the heater to better align with your central HVAC system. You may need to attempt calibration multiple times to align your heater thermostat with your HVAC system.

1. Hold the ON/OFF icon on the heater's control panel for 10 seconds to initiate calibration. The heater will beep and the temperature numbers will flash.
2. Adjust the thermostat by pressing the + and - buttons when the numbers flash.
3. If there is no control input for 5 seconds, the heater will exit thermostat calibration.

*NOTE: Generally, Heat Storm Infrared Heater thermostats are more precise than home central thermostats. Adjusting your Heat Storm Infrared Heater to align with your central system may result in reduced efficiency.*



## Timer

When the heater is off, you can set both delay on and delay off time. Tap on the timer icon to enable edit mode. The display will flash. Use the plus and minus icons to change the "on" time (hour increments).

Tap the timer icon again to set the "delay off" timer. Follow the same instructions above to add or take away time. Wait 5 seconds for the timer setting to activate.

*NOTE: When the heater is on, you can only set the "delay off" timer.*

## Factory reset

Power off heater and allow time for elements to cool. Unplug and plug in heater. Within 3 minutes of plugging in heater, press and hold timer icon for 10 seconds to reset the heater to factory settings.



## Setting the temperature

The default temperature for the heater is 70 °F or 21 °C. Pressing the + or - icons enters temperature setting mode, where the thermostat can be adjusted by 1 °F or 1 °C. The display exits this mode after 5 seconds of inactivity, showing the current ambient temperature.

*NOTE: After the heater function or power is turned off, the blower will continue for several minutes to cool internal components.*

## Selecting Celsius & Fahrenheit

Press the + and - icons at the same time to switch between Celsius and Fahrenheit.

*NOTE: Switching between °C and °F can only be performed using the control panel on the heater, and is not available using the remote control.*



## Change working mode

Press the lightning bolt/volume button to toggle between low, auto, and high working modes.

- **Low mode\***  
Heater operates at 50% power, effectively halving the wattage. This is beneficial for situations where the breaker tends to trip easily or when heating a small space.
- **Auto mode (Eco mode)**  
Heater runs at full power until it's within 2 degrees of the set temperature. It then shifts to 50% power to achieve and maintain the desired temperature. This ensures more frequent, energy-efficient operation while effectively maintaining the set temperature.
- **High mode\***  
Heater runs at 100% power until desired temperature is met.

*NOTE: The fan will turn on and off to circulate air. The heater is trying to determine if the ambient temperature in the room has changed.*

*\*Low and high modes will reach the set temperature, followed by a 2-degree cooling period before reheating.*

## Sound

Press and hold the lightning/volume symbol for 5 seconds to alternate between sound on/off.

---



## Display brightness

Tap on the sun symbol to change the display brightness.

# Maintenance

## WASHABLE LIFETIME FILTER SYSTEM

Heat Storm Infrared Heaters feature a user-friendly, washable lifetime filter. It is advised to clean the filter monthly or as necessary. You can clean the filters with tap water or a vacuum using the following instructions:

### Vacuum method

Gently pass the vacuum wand over the filter cover. Do not remove the cover or the filter when cleaning your heater with the vacuum.

### Water method

1. Locate the two filters on your unit (one on each side).
2. Press both tabs to remove the filter cover and remove the filter, noting which side of the filter receives air flow into the heater.
3. Once removed, run warm tap water over the filter, the opposite direction of air flow, until water runs clear. The filter might excrete some residue, so be cautious not to drip on any stainable surfaces such as carpeting. You can also soak the filter in water mixed with a small amount of mild dish soap (remember to rinse well with clean water after soaking filter).
4. Shake the filter over a sink until excess water is removed and allow it to drip dry completely before reinstalling.
  - DO NOT force or attempt to speed the filter drying process by using any alternative methods.
  - ENSURE that the filter is completely dry before reinstalling.
5. Reinstall the filter and replace cover.



## WARNING

For any maintenance other than filter maintenance, please contact an authorized service representative.

## HEATER MALFUNCTION OR DAMAGE

DO NOT operate if the following occurs:

- Heater has a damaged cord or plug.
- After the heater malfunctions.
- Heater has been dropped or damaged in any manner.

Turn off the heater, disconnect the cord, and have heater inspected by an electrician before reusing.

Discard heater, or return to an authorized service facility for examination and/or repair.

### **Damaged cord or plug**

If the supply cord is damaged, it must be replaced by the manufacture, its service agent, or similarly qualified persons in order to avoid a hazard.

## QUARTZ ELEMENTS LIFE EXPECTANCY

Average element life is 20,000 hours. The quartz elements are replaceable by an authorized service dealer.

# Troubleshooting guide

## RECALIBRATING YOUR HEATER

If your heater is not working like normal, try resetting it. Heaters are like other electronics, sometimes they need a reboot (refer to the factory reset on page 11). If an issue persists, contact customer service at 435-752-6611.

## FAN

### **Not blowing air**

When powering the heater ON, it does not blow any air at first. The initial 15 seconds allow the infrared elements to heat up, ensuring that when the fan turns on, warm air is circulated into the room.

### **Not blowing warm air**

- Ensure the air inlet is not blocked and the air filter is clean. If the filter is dirty, clean it.
- The ambient temperature (displayed) is higher than the thermostat setting.
- There is something blocking the air flow. Move the object out of the way of the heater. This is common if the heater is in a closet or under a desk.

### **Continuing to blow air when heater is turned off**

This is the cool down phase. The heater will run for several minutes (up to 12) to cool the internal components. This increases the lifespan of the infrared elements. If the heater did not finish the cooling procedure when it was unplugged, the fan will blow immediately when the heater is powered back on.

### **Heater fails to reach the set temperature and continues to run.**

Possible reasons for temperature discrepancies:

1. Ensure clean filters.
2. Address drafty or poorly insulated rooms.
3. Keep doors closed for efficient heating.
4. Place the heater on an interior wall, away from windows.
5. If issues persist, consider the heater's size suitability for the room. Optimal for spaces between 150-750 sq. ft., with primary heating around 150 sq. ft.\*

*\*Square footage recommendations may vary based on home insulation.*

Placing the heater near objects can impede air circulation in the room, resulting in uneven temperatures within the same space.

Unplug the unit from the wall outlet for 2 hours. Reconnect the unit after this period. If the issue persists, contact customer service at 435-752-6611.

### **Fan runs for under a minute and then turns off**

The fan is turning on to attempt to create air flow within your room. The heater is trying to determine if the ambient temperature in the room has changed.

## **THERMOSTAT**

### **Ambient temperature reading of the heater different then the reading on my central heating thermostat.**

All thermostats vary in their temperature setting. In most cases, the central heating thermostat is not as accurate as your Heat Storm thermostat. The location of the temperature censor can also alter the thermostat reading.

You can calibrate your heater's thermostat to better match your central heating thermostat. Please see the calibration section of the manual on page 10.

## **BURNING PLASTIC SMELL**

A light plastic odor is normal for new, unused heaters. If the smell persists for more than a couple of hours, call customer service at 435-752-6611.

## **ERROR CODES**

**EE** : Temperature sensor (probe) error, when this code shows, the heating element and fan are turned off. Unplug heater and check if the temperature sensor is loose, disconnected, or damaged.

**EO** : Program setup failure. Unplug and plug in again. If error persists, the PCBA needs to be replaced.

**EI**: Tip-over error. The heater and fan are turned off. Reactivate by pressing the on/off icon after repositioning the heater upright.

**UH**: Incorrect high voltage power supply error. Unplug heater immediately. Attempt plugging the heater into a different outlet and ensure it is the sole major appliance on the circuit.

**LO**: The temperature is less than 16° F (-9 °C)

**HI**: The temperature is greater than 99° F (37°C)

# Returns & exchanges

## 30 DAY RETURN POLICY

Heaters purchased directly from EnergyWise Solutions can receive a refund of the total sales amount if the following conditions are met within 30 days:

1. Product is in new condition.
2. Product is packed in the original manufacturers box and packing material.
3. Original manuals and accessories are included in package.

## EXCHANGES & WARRANTY

After 30 days from the purchase date, the buyer is responsible for all freight/shipping charges associated with exchanges, refunds, or warranty claims for the purchased product.

## 1-year limited warranty

The manufacturer warrants this product and included accessories against defects in materials and workmanship under normal use for a period of ONE (1) YEAR from the date of retail purchase by the original end-user purchaser.

## EXCLUSIONS AND LIMITATIONS

1. Install and operate the electric heater strictly in accordance with the provided instructions at all times. Unauthorized repairs, alterations, willful abuse, accidents, or misuse of the product will void this warranty.
2. This warranty is exclusive to the original owner, valid only if the purchase was made through an authorized supplier of the product, and is non-transferable.
3. The warranty is limited to repairing or replacing defective parts in material or workmanship. This applies only if the said part(s) have been exposed to normal conditions of use and service, confirmed by the manufacturer's inspection.
4. The manufacturer may, at its discretion, fulfill warranty obligations by refunding the wholesale price of the defective part(s).
5. Costs related to installation, labor, construction, transportation, or any other associated expenses arising

from defective part(s), repair, replacement, or otherwise, are not covered by this warranty. The manufacturer disclaims responsibility for such costs.

6. The owner/user assumes all risks, including any direct, indirect, or consequential loss or damage resulting from product use, except as mandated by law.
7. All other warranties, whether expressed or implied, pertaining to the product, its components, accessories, or any manufacturer obligations/liabilities, are expressly excluded. The manufacturer neither assumes nor authorizes any third party to assume additional liabilities related to the product sale.
8. The manufacturer neither assumes nor authorizes any third party to assume on its behalf, any other liabilities with respect to the sale of the product.
9. The warranties as outlined in this document do not apply to non-accessories used in conjunction with the installation of this product.
10. Specific legal rights provided; additional rights may vary by state. Warranty void if prolonged exposure to dampness, unauthorized alteration, willful abuse, accident, misuse, or lack of original purchase receipt.

## WARRANTY REDEMPTION

Reach out to Heat Storm customer service at 435-752-6611 during the warranty period. Please have your sales receipt, purchase location, and product model information ready. Troubleshooting support will be offered over the phone. If the issue persists, you may be requested to email proof of purchase and a photo of the manufacturer sticker to [cs@heatstorm.com](mailto:cs@heatstorm.com).

### **Replacement parts:**

In some cases, we may send you a replacement part along with repair instructions. This is classified as an authorized repair and does not void your warranty.

### **Unit repairs:**

If the situation warrants, we will have you send the defective product to us for inspection. Our technicians will repair the product or provide a new unit if your heater is deemed irreparable. For units beyond the 30-day return policy, shipping costs are the consumers responsibility. If interested in our discounted shipping rates, kindly inform your customer service representative.



**Need help?**

435-752-6611

[cs@heatstorm.com](mailto:cs@heatstorm.com)

[heatstorm.com](https://heatstorm.com)