

# **Motic®**

## **PX43MET**

### Metallurgy Instrument Operation Manual

---



**Note**

If the equipment is used in a manner not specified by the manufacturer, the protection provided by the equipment may be impaired.

WWW.MOTIC.COM

---

MOTIC HONG KONG LIMITED

CE

We are constantly endeavouring to improve our instruments and to adapt them to the requirements of modern research techniques and testing methods. This involves modification to the mechanical structure and optical design of our instruments.

Therefore, all descriptions and illustrations in this instruction manual, including all specifications are subject to change without notice. Hereby, we deeply appreciate that you choose MOTIC instrument, your satisfactions is our best payback!

## CONTENT

<b>1.</b>	<b>NOMENCLATURE</b>	<b>4</b>
1.1	Application	4
1.2	Nomenclature	4
	1.2.1 PX43MET Trinocular left side view	4
	1.2.2 PX43MET Trinocular right side view	5
1.3	Technical data	5
<b>2.</b>	<b>SETTING-UP THE INSTRUMENT</b>	<b>6</b>
2.1	Working Environment	6
2.2	Input voltage and power	6
<b>3.</b>	<b>ASSEMBLING THE MICROSCOPE</b>	<b>7</b>
3.1	Illumination (Halogen)	7
	3.1.1 Halogen bulb	7
	3.1.2 Installing the bulb	7
3.2	Installing the Lamp house	9
3.3	Installing the Objectives	9
3.4	Installing mechanical stage plate	10
3.5	Inserting the Eyepieces	10
3.6	Installing the Analyzer and Polarizer	10
3.7	installing DIC slider, phase slider and adjusting screw	11
3.8	Power cord	11
<b>4.</b>	<b>MICROSCOPE HANDLING</b>	<b>12</b>
4.1	Interpupillary Distance Adjustment	12
4.2	Diopter Adjustment	12
4.3	Coarse and fine focusing	13
4.4	Coarse focus torque adjustment	13
4.5	Adjust the aperture diaphragm	14
4.6	Align up Field Diaphragm and Aperture Diaphragm	14
4.7	Use of Polariser and Analyser	15
4.8	Bright field Observation	16
4.9	Dark field Observation	16

4.10	Polarizing Observation	17
4.11	Brightness and Contrast Adjustment	17
4.12	Filter selection and installation way	17
4.12.1	Installing the shutter slider with the filter holder	18
4.13	Auto/ Off/ On switch function	19
4.14	Stage with Scale for movement reference	19
<b>5.</b>	<b>PHOTOMICROGRAPHIC PROCEDURE (TRINOCULAR ONLY)</b>	<b>20</b>
<b>6.</b>	<b>TROUBLESHOOTING TABLE</b>	<b>21</b>
6.1	Optical and Operating Problems	21
6.2	Electrical	22
<b>7.</b>	<b>CARE AND MAINTENANCE</b>	<b>23</b>
7.1	Lenses and Filters	23
7.2	Cleaning of Painted or Plastic Components	23
7.3	When Not in Use	23
7.4	Warning Label	24

# 1. NOMENCLATURE

## 1.1 Application

PX43MET inverted metallographic microscope, which integrates bright field, dark field, POL, DIC and other observation methods, meets the user's needs for various professional metallographic analysis such as grain size, spheroidization rate, and is widely used in metals, minerals, biomedicine, and materials science, electronic technology and other fields. The instrument can also be equipped with photography and video accessories for photomicrography and video.

## 1.2 Nomenclature

### 1.2.1 PX43MET Trinocular left side view

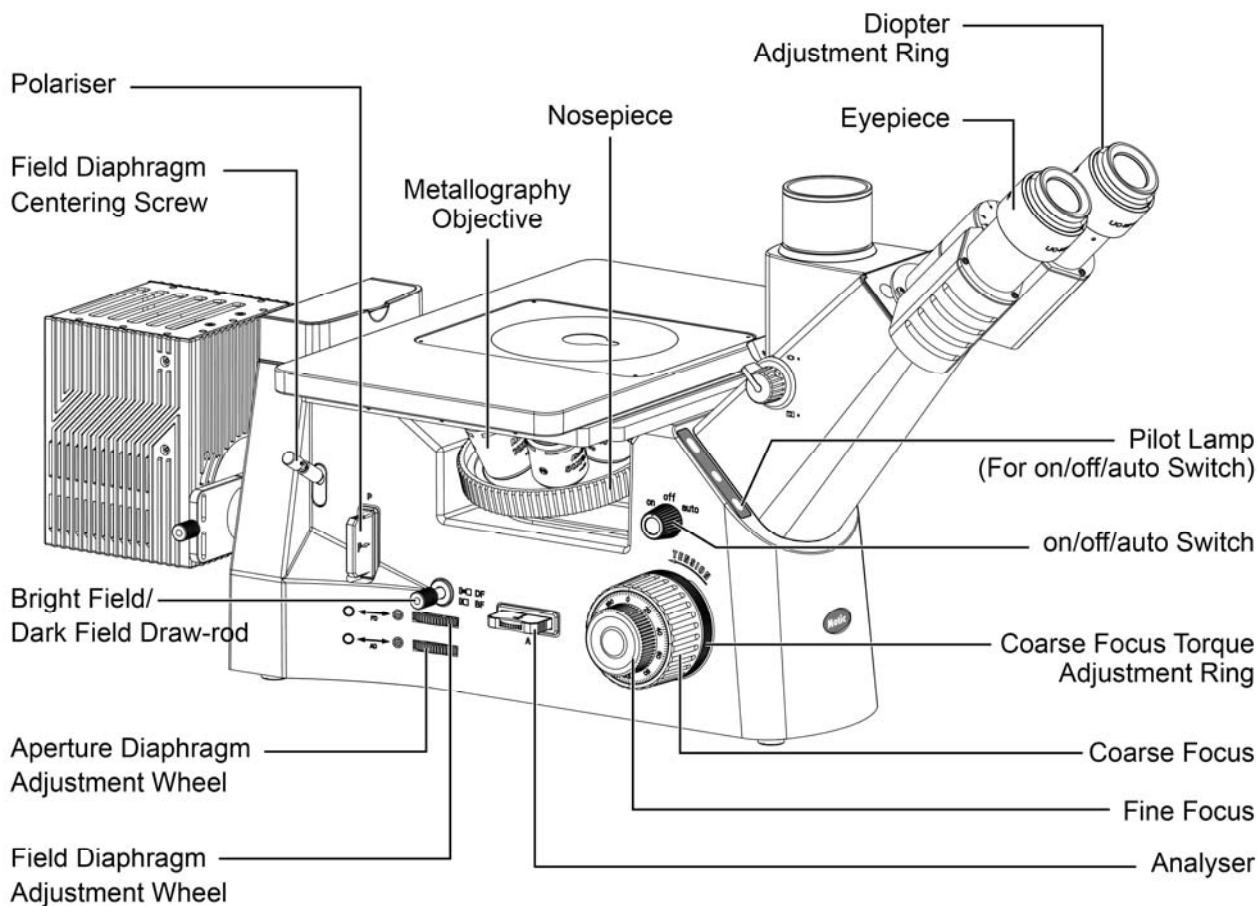

(Fig. 1)

### 1.2.2 PX43MET Trinocular right side view

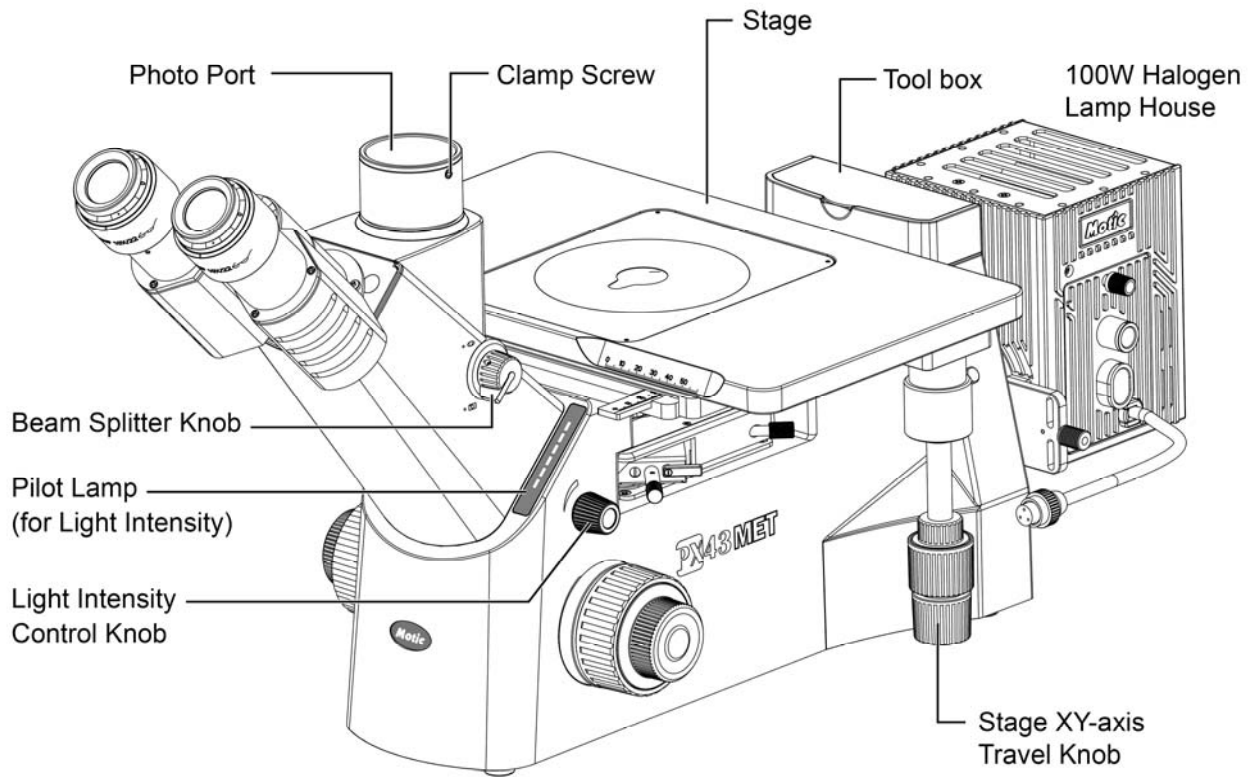

(Fig. 2)

**Note:** Please be aware the accessories are presented in above or following figure, such as: Objectives, Illuminations, Polarisers/Analyser, color filter etc., just for demonstration purpose of operations, please contact your local vendor or seller for more details.

### 1.3 Technical data

<b>Model</b>	<b>PX43MET</b>
Optical System	Color Corrected Infinity Optical System [CCIS®]
Eyepieces	UC-WF 10X/22mm, with diopter adjustment
Observation Tube	Widefield binocular 45°
	Widefield trinocular 45° - light distribution 20/80
Interpupillary Distance	48 ~ 75mm
Nosepiece	Left side orientated, quintuple.
Focus	Coaxial system
	Coarse focus with torque adjustment
	Fine focus with 2µm minimum increment
Mechanical Stage	320X194mm surface; 50X50mm movement
Illumination	12V/100W halogen Koehler illumination

## 2. SETTING-UP THE INSTRUMENT

### 2.1 Working Environment

The location should be free from dust, moisture, chemical vapours and from mechanical vibrations. Don't locate the instrument in bright or direct ambient light, in front of a lamp, or a will-lit bright wall. Best image will be achieved without significant ambient light.

Environmental condition:

- Indoor use
- Altitude: Max 2000m
- Ambient temperature: 5°C~ 40°C;
- Maximum relative humidity: 80 % for temperatures up to 31 °C decreasing linearly to 50 % relative humidity at 40°C
- Supply voltage fluctuations: Not to exceed  $\pm 10\%$  of the normal voltage
- Pollution degree: 2
- Installation/ Overvoltage category: 2`
- Air Pressure of 75kPa to 106kPa

### 2.2 Input voltage and power

Automatic voltage selection works with electrical outlets worldwide. It is advised to always use a power cord that is rated for the voltage used in your area and that has been approved to meet local safety standards. Using the wrong power cord could cause fire or equipment damage.



In order to prevent electric fluctuation to the instrument electrics, always turn the power switch on the instrument off before connecting the power cord.

#### 100W Halogen

- Rating:  
Power Adaptor Input: 100-240Vac, 50-60Hz, 1.6A  
Main Unit Input: 15Vdc, 4.2A  
Halogen Lamp Input: 12Vdc, 100W

**Attention:** The plug of the power adaptor is the "**disconnect device**" for whole unit. To save energy we recommend to unplug the instrument when not in use.

The device is specified to connect to the following power adaptor:

- SINPRO ELECTRONICS CO LTD, Model: IPU63-106
- Input: 100-240Vac, 50-60Hz, 1.6A

## 3. ASSEMBLING THE MICROSCOPE

### 3.1 Illumination (Halogen)

#### 3.1.1 Halogen bulb

The quartz halogen bulb, used as a light source, has higher luminance and colour temperature than conventional tungsten lamps. The luminance of halogen bulb is approximately four times brighter than the conventional tungsten lamps.

As long as the lamp voltage is kept constant, the halogen lamp maintains the same level of brightness and colour temperature regardless of whether it is new or nearing the end of its life span.

#### 3.1.2 Installing the bulb



In order to prevent electric shock please always make sure the **power switch** in “**off**” position and unplug the power cord before installing or replacing the lamp.



The bulb and the lamphouse become very hot during and after a period of operation. Risk of burn – Do not touch the bulb during or immediately after a period of operation. Make sure the bulb has cooled sufficiently before attempting to replace the lamp.

#### 100W Halogen

- The applicable halogen bulbs are the 12V 100W HAL high-intensity bulb. (Osram, model: 64625 HLX)
- In order to prevent electric shock always turn the power switch off and unplug the power cord before installing or replacing the lamp.
- Loosen the lamp housing cover clamp screw (Fig. 3a) and remove the cover (Fig. 3b).
- When installing the bulb, do not touch the glass surface of the bulb with bare fingers. (Fig. 3d) Doing so will cause fingerprints, grease, etc., to burn onto the bulb surface, reducing the illumination provided by the bulb. If the surface is contaminated, wipe it clean using lens tissue.
- Firmly insert the bulb into the socket pinholes until it reaches the limit. Be careful not to tilt the bulb when mounting. (Fig. 3d)
- Close the cover and secure with it with lamp housing cover clamp screw. (Fig. 3e)

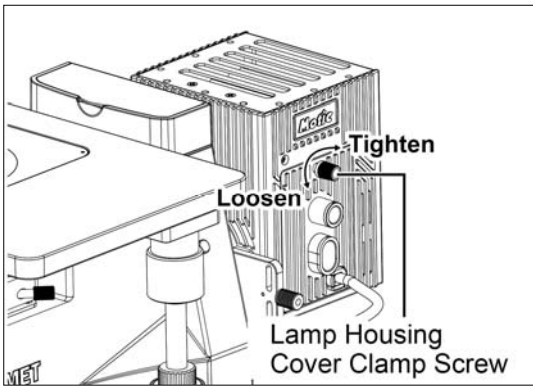

(Fig. 3a)

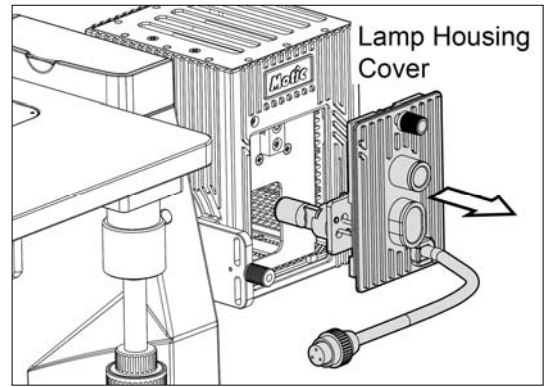

(Fig. 3b)

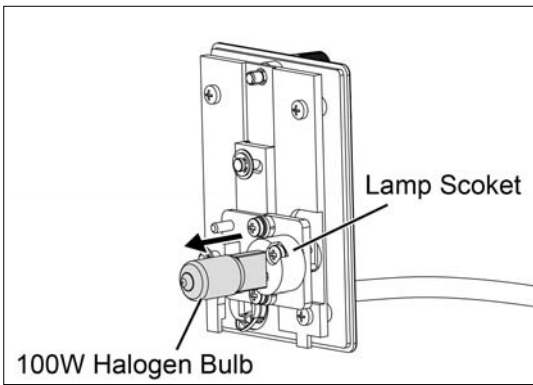

(Fig. 3c)

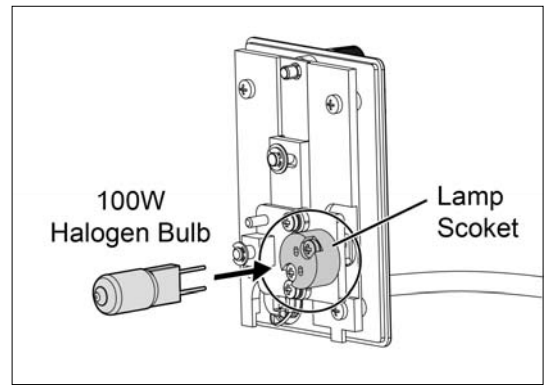

(Fig. 3d)

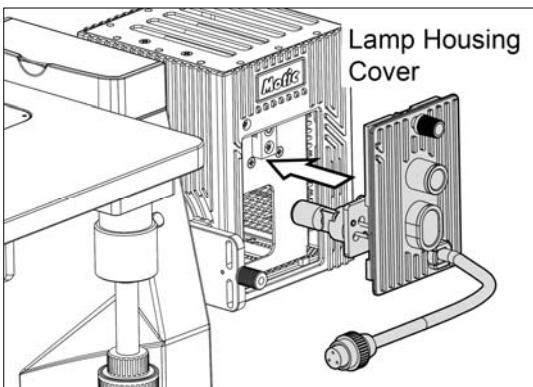

(Fig. 3e)

### 3.2 Installing the Lamp house

#### 100W Halogen

- Loosen the round dovetail clamp screw (2.5mm Allen key screw) on the microscope stand, insert the lamp house into the round dovetail on the microscope stand. (Fig. 4a)
- Tighten the clamp screw to secure the lamp house in place (Fig. 4b).
- Connect the lamp house cord with stand. (Fig. 4a)

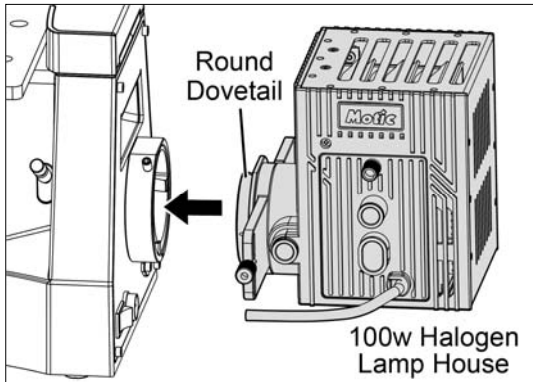

(Fig. 4a)

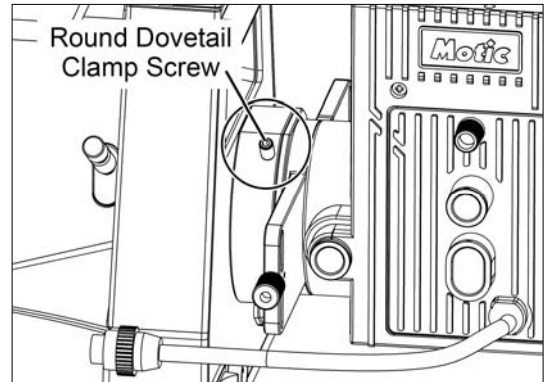

(Fig. 4b)

### 3.3 Installing the Objectives

- Hold an objective and screw it in the nosepiece thread hole till its limited position gradually then revolve the nosepiece in clockwise direction.
- Install the next objective in blank thread hole as needs, following the above approach. (Fig. 5)

**Caution:** to guarantee the precision please use even force to screw objective in thread holes, any violation may influence the quality of imaging and illumination of microscope negatively.

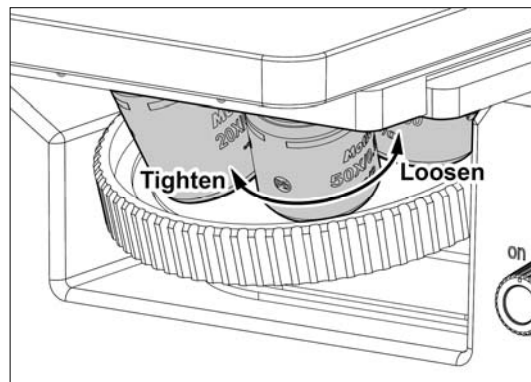

(Fig. 5)

### 3.4 Installing mechanical stage plate (Fig. 6)

- Place the stage plate vertically on the corresponding position of the mechanical stage.

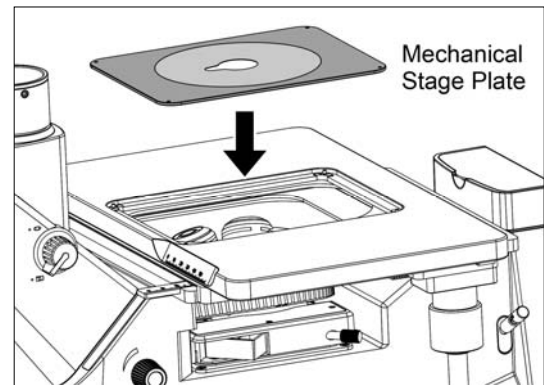

(Fig. 6)

### 3.5 Inserting the Eyepieces

- Remove the dust caps from one eyepiece tube.
- Spirally Insert one eyepiece into the eyepiece sleeve till its limited position.
- Install the next eyepiece as above approach.
- Install the rubber eye guards. (Fig. 7)

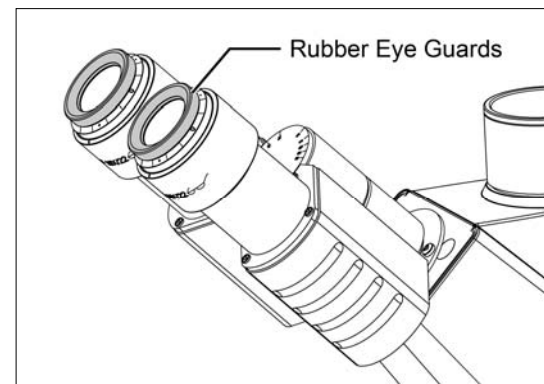

(Fig. 7)

### 3.6 Installing the Analyzer and Polarizer

- Make sure analyzer or polarizer clean
- Insert the polarizer (Fig. 8a) or analyzer (Fig. 8b) into the optical path.

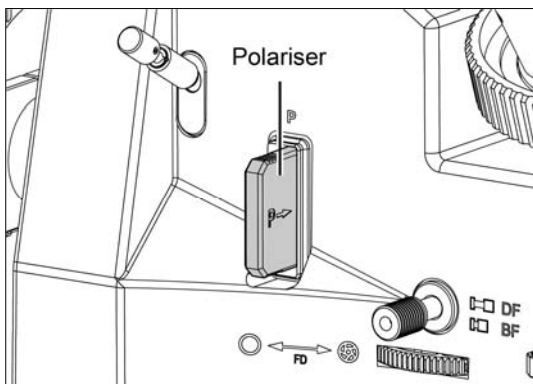

(Fig. 8a)

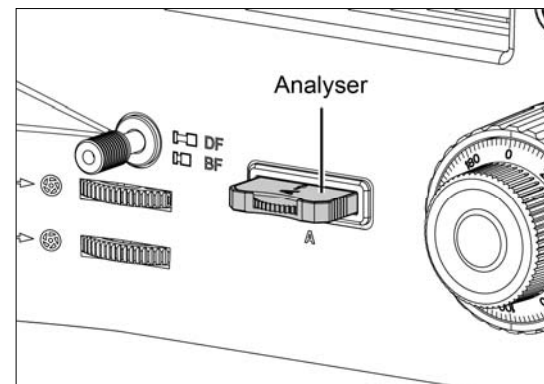

(Fig. 8b)

### 3.7 Installing DIC slider, phase slider and adjusting screw

- Insert the DIC slider (Fig. 9a) and the phase slider (Fig. 9b) into the DIC socket of the nosepiece vertically according to the orientation shown in the figure, and push it to the end. When it can no longer be inserted, use (Fig. 9a and Fig. 9b) to tighten the adjusting screw.

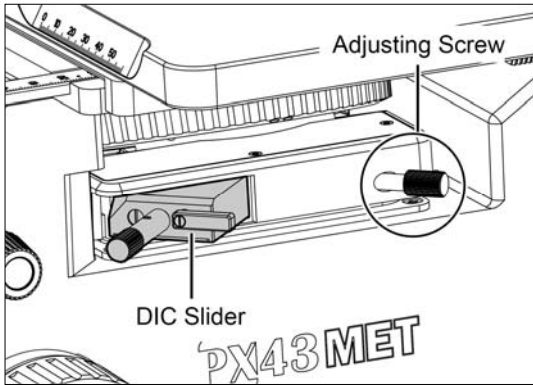

(Fig. 9a)

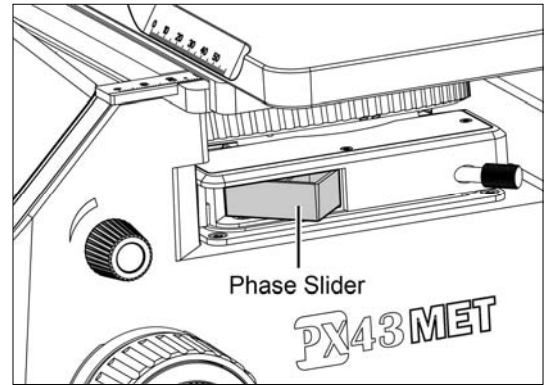

(Fig. 9b)

### 3.8 Power cord

- Make sure the power cord complying with the local power supply specification
- Connect the socket of the power cord to the AC inlet on the rear of the base of the microscope. (Fig. 10)
- Plug in the other end of the cord to an AC outlet with ground conductor.

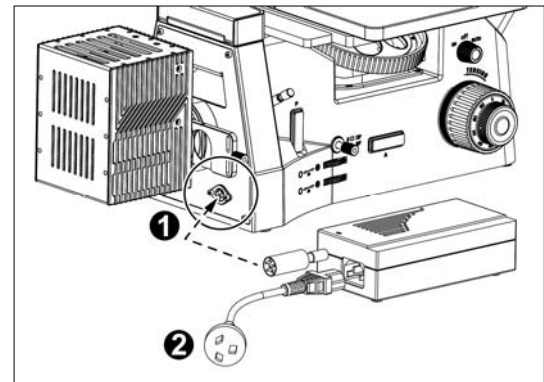

(Fig. 10)

## 4. MICROSCOPE HANDLING

### 4.1 Interpupillary Distance Adjustment

- Before adjusting the interpupillary distance, bring a specimen into focus using the 10x objective.
- Adjust the interpupillary distance so that both the right and left field of view become one (Fig. 11). This adjustment will enable the user to observe the specimen with both eyes.

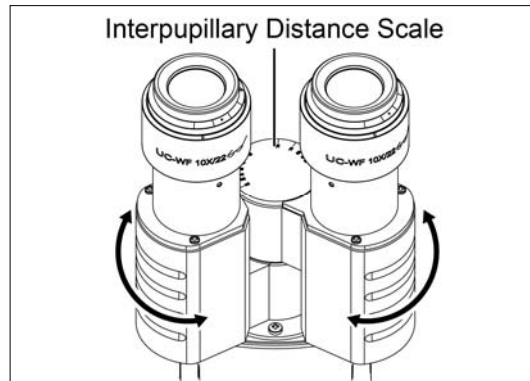

(Fig. 11)

### 4.2 Diopter Adjustment

Diopter adjustment compensates for the differences in vision between the left and right eyes. In addition to making observation through both eyes easier, this adjustment also reduces the extent to which focusing is lost when the objective magnification is changed. In particular, this occurs when a low magnification objective is used.

- Set the diopter on both eyepieces to the “0” position.
- Swing in the 10x objective, focus with one eye only (as everybody has got a “strong” eye, use this one for this first focussing).
- When in focus, close this eye and use the other one. Focus by only using the diopter ring (Fig. 12) on the respective eyepiece, do not use the coarse/fine knob!
- Change to a higher magnification and repeat the above procedure as needs.
- As the focus depth is less in high magnification lenses, a precise adjustment of the diopters here is easier. Keep this final diopter position for all lenses.

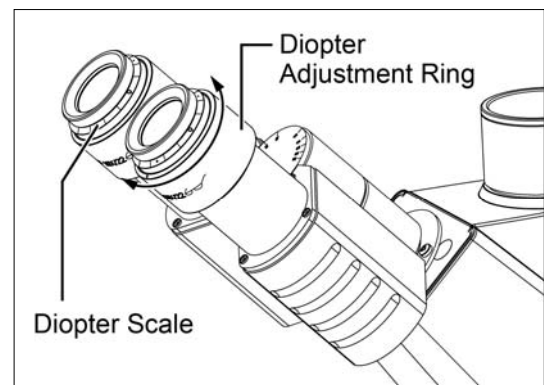

(Fig. 12)

#### 4.3 Coarse and fine focusing

- For focusing of the instrument please use the coarse and fine focus knobs on the left and right side of the microscope stand. (Fig. 13a)
- The direction of vertical movement of the revolving nosepiece corresponds to the turning direction of the focus knob.
- One full rotation of the fine focus knob moves the nosepiece 0.2mm in z-direction. One scale unit on the fine focus knob equals 2 microns.

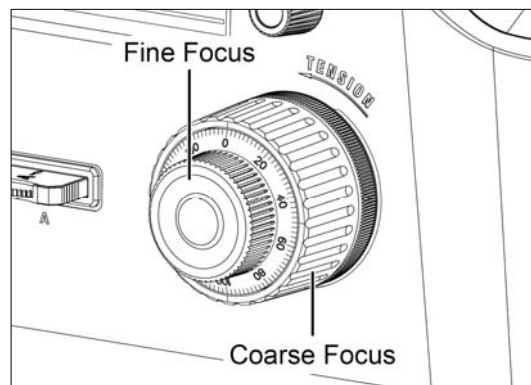

(Fig. 13a)

#### Cautions for behavior need avoid, which will damage the precision of Instrument directly:

- Never rotate the left or right knob while holding the other.
- Never try to turn the coarse and fine focus knob beyond their limitation position.
- Never try to grasp the coarse and fine focus knob to rotate together

#### 4.4 Coarse focus torque adjustment

- To increase the torque, turn the torque adjustment ring in the direction of the arrow located at the left-hand coarse focus.
- To reduce the torque, turn the ring in the opposite direction of the arrow. (Fig. 13b)

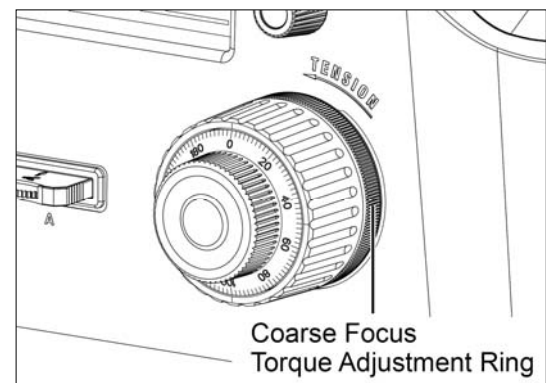

(Fig. 13b)

#### 4.5 Adjust the aperture diaphragm

- Rotate the aperture diaphragm adjustment wheel (Fig. 14), the diameter of Aperture diaphragm will become small or big accordingly.
- Adjust the appropriate diameter of Aperture diaphragm can avoid overexposure, stray light and improve the contrast. Normally bigger magnification use need bigger diameter of Aperture Diaphragm, vice versa; if want to obtain the improved imaging contrast a little bit, need gradually close down the Aperture Diaphragm, then Dark field observation need fully open the Aperture diaphragm.

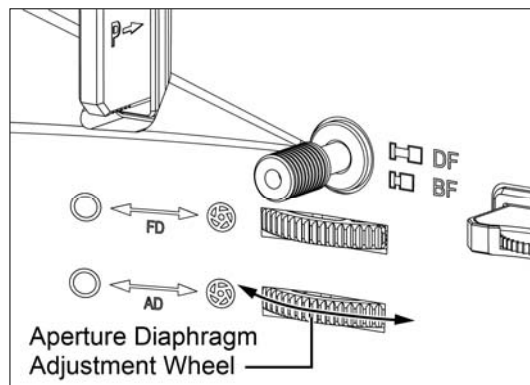

(Fig. 14)

#### 4.6 Align up Field Diaphragm and Aperture Diaphragm

Before start to use microscope to observe the specimen or sample, please do make sure the Field Diaphragm center and Aperture Diaphragm center be coaxial seriously, to fully activate MOTIC CCIS infinity optic system performance

- Adjust the field diaphragm until aperture diaphragm is 2/3 of field then center the field diaphragm (Fig. 15a) via rotating the right/ left field diaphragm centering screw (Fig. 15b).
- Set the field diaphragm slightly bigger than the field of view (Fig. 16a) by turning the adjustment wheel. (Fig. 16b)

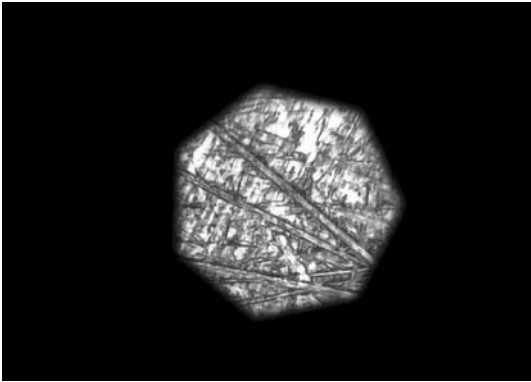

(Fig. 15a)

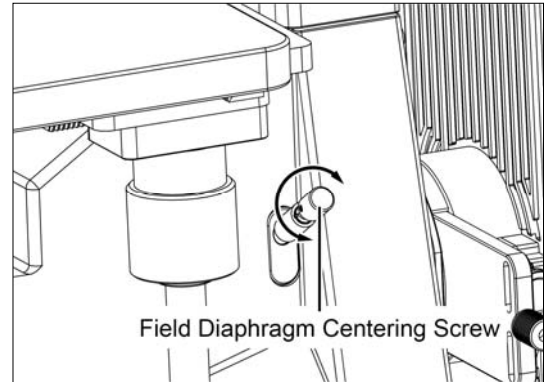

(Fig. 15b)

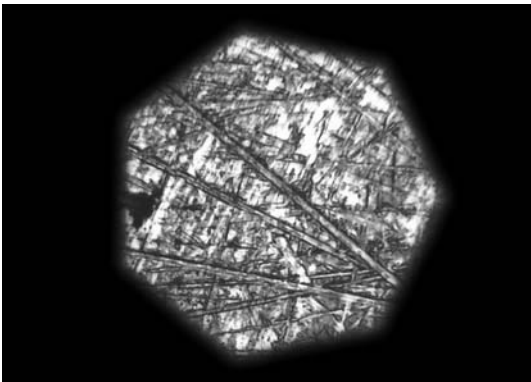

(Fig. 16a)

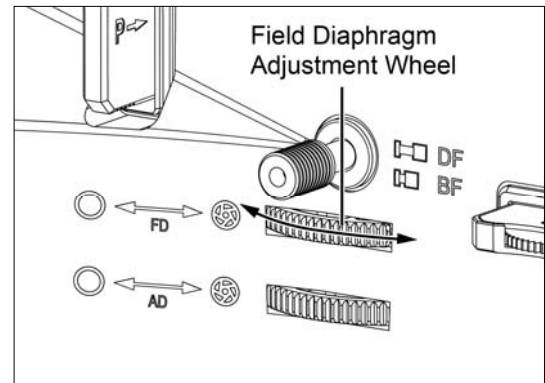

(Fig. 16b)

#### 4.7 Use of Polariser and Analyser (Fig. 17)

- Insert the polariser (marked with “P”) into the slot.
- Insert the Analyser (marked with “A”) into the slot.
- Analyser is rotatable and the color of specimen/ Sample with polarization will be changed when rotating.

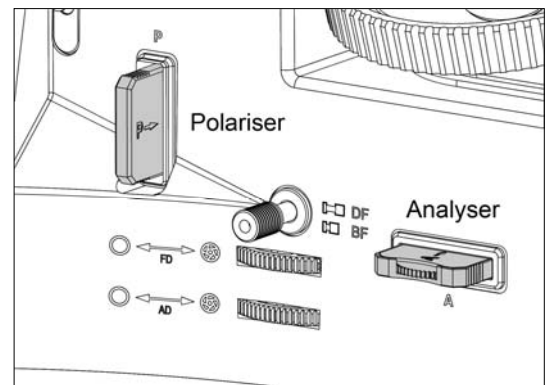

(Fig. 17)

#### Note:

1. Before inserting Polariser and Analyser in slot please make sure the filter surface is dust-free, for cleaning method please refer to **chapter 7. “CARE AND MAINTENANCE”**
2. Before starting to observation, please make sure **chapter 4.6** has been set up properly.

#### 4.8 Bright field Observation

- Adjust the aperture diaphragm in the center of optical axis (Adjusted already in factory)
- Push the draw-rod in the BF position (Fig. 18)
- Closing the aperture diaphragm will lower the resolution and brightness but increase the contrast and depth of focus.

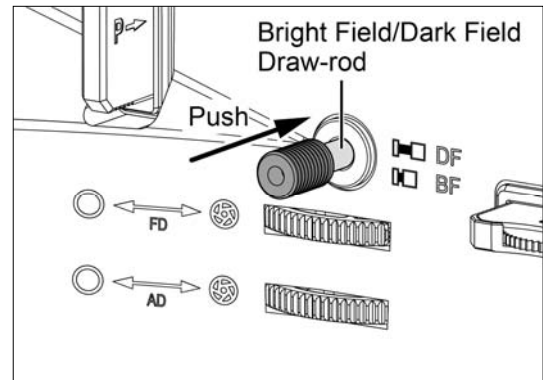

(Fig. 18)

#### 4.9 Dark field Observation

- Open the aperture diaphragm fully.
- Pull the draw-rod in the DF position. (Fig. 19)  
PX43MET standard configuration have equipped with LM BD objective, which can perform bright field observation and dark field observation conveniently, no need to change the objective

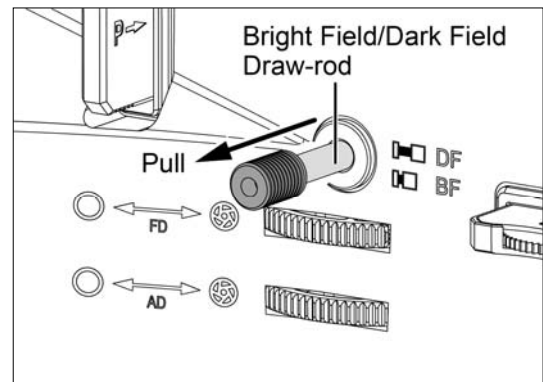

(Fig. 19)

#### 4.10 Polarizing Observation

- Insert the polariser (marked with “P”) into the slot. (Fig. 20-1)
- Insert the Analyser (marked with “A”) into the slot. (Fig. 20-2)
- Rotate the analyser according to demands.

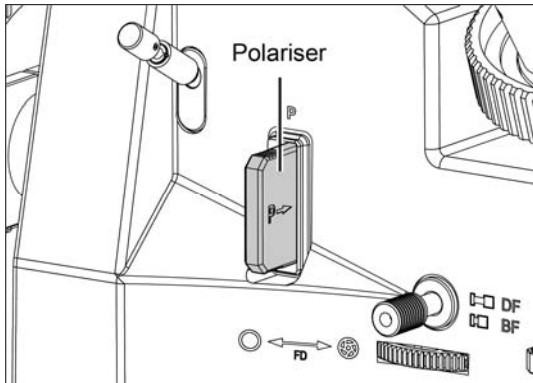

(Fig. 20a)

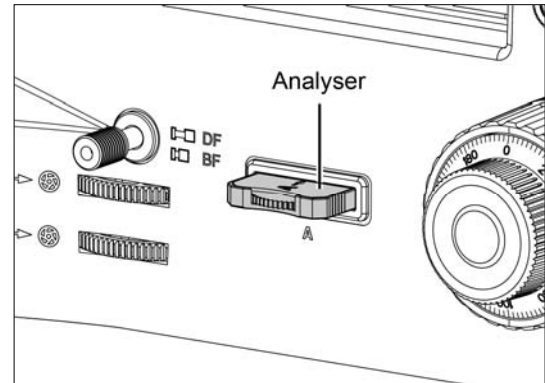

(Fig. 20b)

#### Note:

1. Before inserting Polariser and Analyser in slot please make sure the filter surface is dust-free, for cleaning method please refer to **item 7. “CARE AND MAINTENANCE”**
2. Before starting to observation, please make sure **item 4.6** has been set up properly

#### 4.11 Brightness and Contrast Adjustment

- Blue filter is used for increasing color temperature in routine bright field microscopy
- Frosted filter reduces irregularity in the illumination field, but also reduces the brightness. To ensure enough brightness and better image quality, remove the frosted filter out of light path when using the high magnification objective and low reflectivity of sample.
- For the best contrast and image quality, adjust the condenser aperture diaphragm accordingly when the objective changed.

#### 4.12 Filter selection and installation way

Filter type	Procedure
ND (Neutral Density) filter	For intensity adjustment in photomicrography
Blue filter	For general microscopy and colour photomicrography

#### 4.12.1 Installing the shutter slider with the filter holder

- Loosen one of the slider knobs. (Fig. 21a)
- With the filter slider slot to the left and facing the operator (Fig. 21b), insert the slider into the opening of the main body of the fluorescence attachment. (Fig. 21c)
- Tighten the loosened knob. (Fig. 21a)

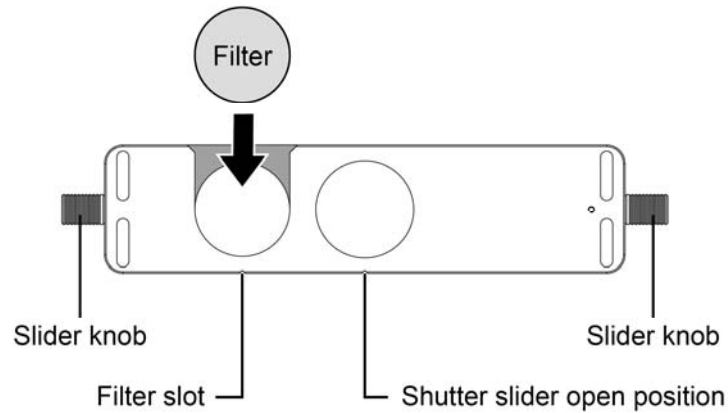

(Fig. 21a)

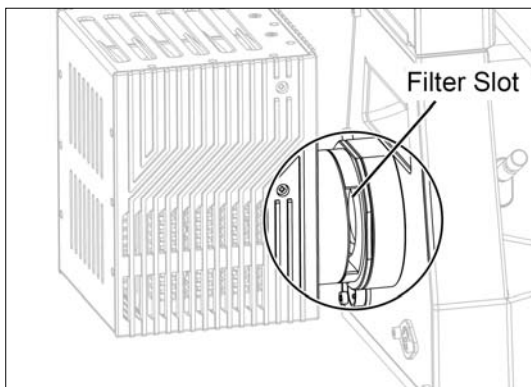

(Fig. 21b)

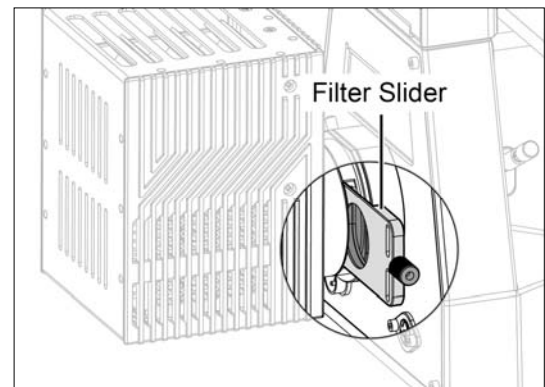

(Fig. 21c)

#### Note:

1. Before inserting filter in slot, please make sure the filter surface is dust-free, for cleaning method please refer to **chapter 7. "CARE AND MAINTENANCE"**
2. Before starting to observation, please make sure **chapter 4.6** has been set up properly.

#### 4.13 Auto / Off / On switch function

- If **“Auto”** is selected, the light will automatically turn off after 15 minutes when no user in front of unit ( not people, desk, wall, book, or curtain around it within 1 meter)
- The distance for black clothes and barrier should be shorter.
- The sensor should not be put under sunshine or UV, or the function of auto will be invalidation.

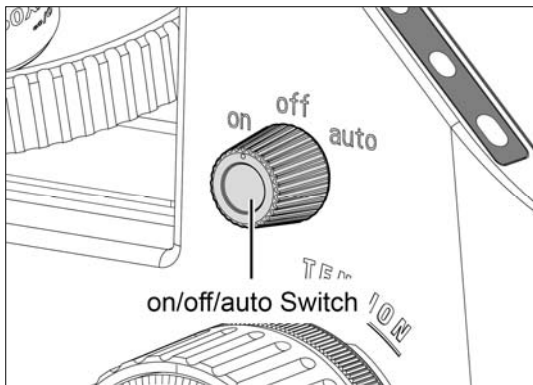

(Fig. 22a)

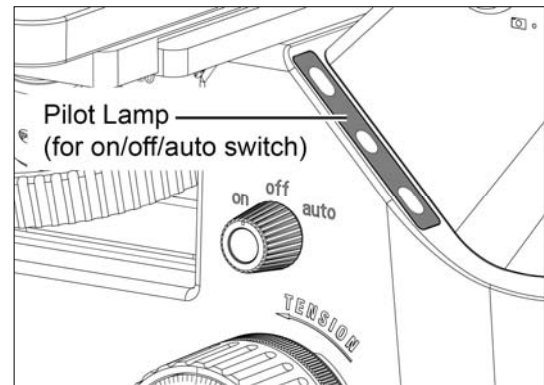

(Fig. 22b)

- The power control knob is located above the left focusing knob. (Fig. 22a)
- When **“Auto”** is selected (Fig. 22a), the blue pilot lamp indicates that an IR-sensor is activated (Fig. 22b). If no user is detected in front of the microscope, the microscope illumination will automatically switch off after 15 minutes.  
When the user returns, the illumination will start again.

#### Caution:

Never attempt to switch forth and back between “On” and “Auto” directly.

The pause at “Off” position is necessary between auto power off mode and normal mode.

#### 4.14 Stage with Scale for movement reference

(Fig. 23)

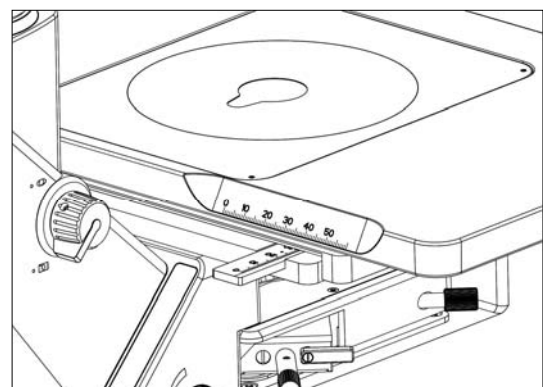

(Fig. 23)

## 5. PHOTOMICROGRAPHIC PROCEDURE (TRINOCULAR ONLY)

- To ensure vibration free operation, set the microscope on a sturdy vibration free table or a bench with a vibration proof device.
- Turn the beam splitter knob (Fig. 24) of the eyepiece tube to the “need  icon” photo position. The photo port is activated, 80% of the light will enter the camera.
- Select a blue filter for routine application. An additional colour-compensating filter can also be used depending on the colour rendition.
- A change of depth of focus, contrast and resolution of image is attainable with an aperture setting of about 2/3 maximum. Fine setting of the condenser aperture is depending on the individual sample.
- For photomicrographic operation, please refer to the manual of the specific camera being used.

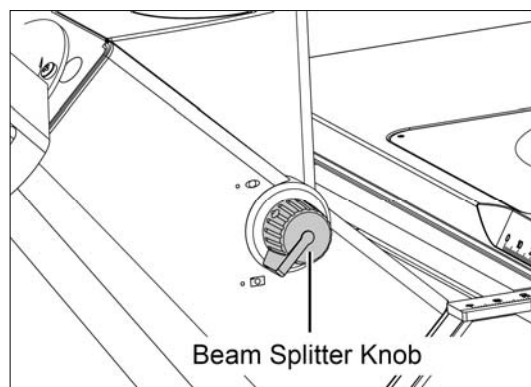

(Fig. 24)

## 6. TROUBLESHOOTING TABLE

If you occasionally suffer a problem. Please refer to the troubleshooting table as below first, which contains the most frequently encountered problems and the possible causes. If still cannot solve the problem, please contact your local agency or service center for next step of troubleshooting, never attempt to dismantle or disassembly the instrument without expertise assistances or supports, thanks for you choosing MOTIC microscope kindly.

### 6.1 Optical and Operating Problems

Problem	Possible Cause
Vignetting or uneven brightness in the field of view or field of view only partially visible	Lamp not installed properly or lamp dirty
	Frosted glass is not placed in properly
	Use error specimen (low reflection)
	Aperture diaphragm is too small
	Polarizing inset not on the orientation position
	Nosepiece is not on the orientation position
	Light path is not in position on the levers of switch orientation
Field of view dirty	Dust on specimen surface
	Dust on objective, filter, condenser or eyepiece
Poor image quality (low resolution, poor contrast)	Lower brightness or incorrect illumination
	Aperture diaphragm is not match with objective aperture
	Use the cover glass specimen
	Dust or scratch on objective lens surface
	Grease on eyepiece
	Improper environment condition, such as: high moisture, floating dust etc.

## 6.2 Electrical

<b>Problem</b>	<b>Possible Cause</b>
Lamp does not light	Power supply not plugged in right position of socket
	Lamp not installed properly
	User left more than 15 minutes under auto mode
	Lamp burnt out or end of life
Inadequate brightness	Specified lamp not being used
Lamp blows out immediately	Specified lamp not being used
Lamp flickers	Connectors are not securely connected
	Lamp near end of life time
	Lamp not securely plugged into socket

## 7. CARE AND MAINTENANCE

### 7.1 Lenses and Filters

- To clean lens surfaces or filters, first remove dust using an air blower. If dust still exists, use a soft / clean brush or gauze.
- A soft gauze or lens tissue lightly moistened with the mixture of alcohol and ether ( ratio:alcohol: 3 and ether: 7) should only be used to remove grease or fingerprints.
- Use the mixture of alcohol and ether only to remove immersion oil from objective lenses.
- Because the mixture of alcohol and ether is highly flammable, be careful handling around open flame.
- Do not use same area of gauze or lens tissue to wipe more than once.

### 7.2 Cleaning of Painted or Plastic Components

- Do not use organic solvents (thinners, alcohol, ether, etc.). The move could result in discolouration or degrading the paint.
- For stubborn dirt, moisten a piece of gauze with diluted detergent and wipe clean.
- For plastic components, only moisten a piece of gauze with water and wipe clean.

### 7.3 When Not in Use





- When not in use, cover the instrument with vinyl dust cover and store in a place low in humidity where mould is not likely to form.
- Store the objectives, eyepieces and filters in a container or desiccator with drying agent.

#### **Note:**

If the operations violate the instructions specified by the manufacturer, the warranty listed in the guarantee terms may be impaired.

#### 7.4 Warning Label

The following warning labels (or symbols) are found on the microscope, study the meaning of the warning labels (or symbols) and always use the equipment in the safest possible manner.

Warning Label / Symbol	Explanation
	Indicates that the surface becomes hot, and should not be touched with bare hands.
	Indicates alternating current.
	Indicates direct current.
	CAUTION! Risk of danger. Please consult documentation in all cases where this symbol is used.

The bulb and the lamphouse become very hot during and after a period of operation.

Risk of burn – Do not touch the bulb during or immediately after a period of operation.

Make sure the bulb has cooled sufficiently before attempting to replace the bulb.

Don't pick the microscope up from the bottom during equipment operation.



NO.: 1300901112701

**Motic Hong Kong Limited (Hong Kong)**

Unit 1712, 17th Floor, Exchange Tower, 33 Wang Chiu Road, Kowloon Bay, Kowloon, Hong Kong  
Tel: 852-2837 0888 Fax: 852-2882 2792

**Motic Instruments Inc. (Canada)**

130-4611 Viking Way, Richmond, B.C., V6V 2K9 Canada Tel: 1-877-977 4717 Fax: 1-604-303 9043

**Motic Deutschland GmbH (Germany)**

Christian-Kremp-Strasse 11 D-35578 Wetzlar, Germany Tel: 49-6441-210 010 Fax: 49-6441-210 0122

**Motic Europe (Spain)**

C. Les Corts 12, Pol. Ind. Les Corts. 08349 Cabrera de Mar, Barcelona, Spain Tel: 34-93-756 6286 Fax: 34-93-756 6287

Website: <http://www.motic.com>

E-mail: [info@moticon.com.hk](mailto:info@moticon.com.hk)

**Motic China Group., Ltd. (China)**

Motic Building, Torch Hi-Tech Industrial, Development Zone, Xiamen P.R.C. Tel: 86-0592-562 7866 Fax: 86-0592-562 7855

© 2007-2023 Motic China Group Co., Ltd. All rights reserved. Motic is a registered trademark and service mark of Motic China Group Co., Ltd. Microsoft Windows logo is a registered trademark of Microsoft Corporation. All other trademarks are the property of their respective owners.

Design Change: The manufacturer reserves the right to make changes in instrument design in accordance with scientific and mechanical progress, without notice and without obligation.

