



# ESSENTIAL SERIES

GENERAL PURPOSE LED BULBS

## KT-LED6.5MR16-S-8XX-GU10 /G2

50W REPLACEMENT LAMP

### DESCRIPTION

6.5W MR16 Lamp | 2700–5000K |  $\geq 80$  CRI | Spot Light



Enclosed  
Fixture Rated



**3 YEAR**  
WARRANTY



**LAMP TYPE:** MR16

**BASE TYPE:** GU10

**WATTAGE:** 6.5W

**COLOR TEMPERATURE:** 2700–5000K

**COLOR RENDERING INDEX (CRI):**  $\geq 80$

**WARRANTY:** 3 Years

**RATED LIFE:** L70 (25,000 Hours)

### TYPICAL APPLICATIONS

- Track-lighting
- Display
- Under-cabinet
- Outdoor landscaping (with suitable protection from the elements)

### PRODUCT FEATURES

- Energy efficient, 80%+ energy savings over legacy equivalents
- Lower heat generation than legacy equivalents
- ANSI compliant construction ensures fitment for intended applications
- Precision-crafted, full-face optics for precise beam angle control
- Durable plastic housing lowers the risk of breakage
- Long life minimizes replacement and maintenance costs
- Compatible with Keystone low voltage transformers
- Smooth, uniform dimming
- Suitable for damp locations
- Operating temperature range  $-4^{\circ}\text{F}/-20^{\circ}\text{C}$  to  $95^{\circ}\text{F}/35^{\circ}\text{C}$
- $\text{PF} > 0.70$
- Rated for open, recessed, and enclosed fixtures
- UL Listed
- Complies with Part 15 of FCC

### PERFORMANCE SPECIFICATIONS

Keystone Catalog Number	Base Type	Rated Lamp Wattage	Legacy Equivalent Wattage	Color Temp	Lumens	Efficacy	Input Voltage	CRI	Beam Angle	Dimmable
KT-LED6.5MR16-S-827-GU10 /G2	GU10	6.5W	50W halogen	2700K	500	77 lm/W	120V	$\geq 80$	40°	Yes
KT-LED6.5MR16-S-830-GU10 /G2	GU10	6.5W	50W halogen	3000K	500	77 lm/W	120V	$\geq 80$	40°	Yes
KT-LED6.5MR16-S-840-GU10 /G2	GU10	6.5W	50W halogen	4000K	500	77 lm/W	120V	$\geq 80$	40°	Yes
KT-LED6.5MR16-S-850-GU10 /G2	GU10	6.5W	50W halogen	5000K	500	77 lm/W	120V	$\geq 80$	40°	Yes

# KT-LED6.5MR16-S-8XX-GU10 /G2

## 50W REPLACEMENT LAMP

### PHYSICAL SPECIFICATIONS

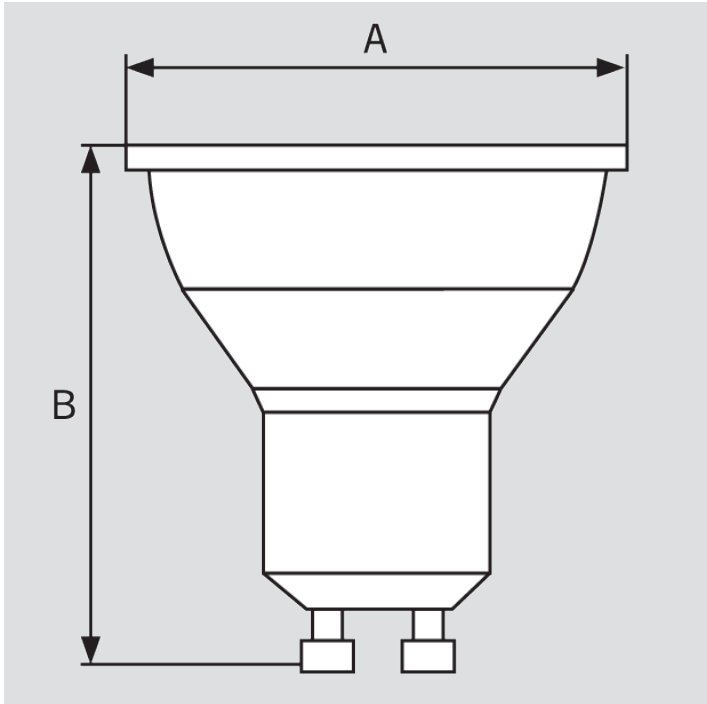

### LAMP DIMENSIONS

A (Diameter)	1.97"
B (Length)	2.19"

BASE TYPE: GU10

### PACKAGING

Carton Quantity	60 pcs
Carton Dimensions	12.95" × 10.91" × 6.54"
Carton Weight	9.5 lbs

### ORDERING INFORMATION

ORDER CODE	EASY CODE	UPC
KT-LED6.5MR16-S-827-GU10 /G2	YGE-97	843654138565
KT-LED6.5MR16-S-830-GU10 /G2	SWO-33	843654138572
KT-LED6.5MR16-S-840-GU10 /G2	ZXH-76	843654138589
KT-LED6.5MR16-S-850-GU10 /G2	DGK-79	843654138596

### CATALOG NUMBER BREAKDOWN

# KT-LED6.5MR16-S-8XX-GU10 /G2

1 2 3 4 5 6 7 8 9

- 1 Keystone Technologies
- 2 LED Lamp
- 3 Wattage
- 4 Multi-Faceted Reflector
- 5 Spot Light
- 6 80 CRI
- 7 CCT
- 8 Base Type
- 9 Generation 2