

## QSFP28-100GB-SR4-LP-AR-AO

Arista Networks® Compatible TAA 100GBase-SR4 QSFP28 Transceiver Low Power (MMF, 850nm, 100m, MPO, DOM)

### Features

- Up to 28.05 Gbps data rate per channel
- High Reliability 850nm VCSEL technology
- Compliant with QSFP28 MSA
- Compliant to IEEE 802.3bm
- Standard 12-lane with MPO connector
- Digital diagnostic SFF-8636 compliant
- Commercial Temperature 0 to 70 Celsius
- Power Dissipation:
- RoHS Compliant and lead-free
- Hot Pluggable



### Applications

- 100GBase Ethernet
- Access and Enterprise

### Product Description

This Arista Networks® QSFP28 transceiver provides 100GBase-SR4 throughput up to 100m over OM4 multi-mode fiber (MMF) using a wavelength of 850nm via an MPO connector. It is guaranteed to be 100% compatible with the equivalent Arista Networks® transceiver. This easy to install, hot swappable transceiver has been programmed, uniquely serialized and data-traffic and application tested to ensure that it will initialize and perform identically. Digital optical monitoring (DOM) support is also present to allow access to real-time operating parameters. This transceiver is Trade Agreements Act (TAA) compliant. We stand behind the quality of our products and proudly offer a limited lifetime warranty.

AddOn's transceivers are RoHS compliant and lead-free.

TAA refers to the Trade Agreements Act (19 U.S.C. & 2501-2581), which is intended to foster fair and open international trade. TAA requires that the U.S. Government may acquire only "U.S. – made or designated country end products."



## Absolute Maximum Ratings

Parameter	Symbol	Min.	Typ.	Max.	Unit	Notes
Power Supply Voltage	Vcc	-0.3		4	V	
Storage Temperature	Tstg	-40		85	°C	
Case Operating Temperature	Tc	0		70	°C	Without Air Flow
Relative Humidity	RH	5		95	%	
Signal Input Voltage		Vcc-0.3		Vcc+0.3	V	
Data Rate	BR		25.78125	28.05	Gbps	Each Channel
Transmission Distance	TD			100	m	1

### Notes:

1. OM4, or 70m on OM3.
2. 100GBase-SR4 and ITU-T OTU4 have different register settings not auto-negotiation.

## Electrical Characteristics

Parameter	Symbol	Min.	Typ.	Max.	Unit	Notes
Power Supply Voltage	Vcc	3.14	3.3	3.46	V	
Power Supply Current	Icc			600	mA	
<b>Transmitter</b>						
Input Differential Impedance	RIN		100		Ω	1
Differential Data Input Swing	VIN,pp	180		1000	mV	
Single-Ended Input Voltage Tolerance	VIN	-0.3		4.0	V	
<b>Receiver</b>						
Differential Data Output Swing	VOUT,pp	300		850	mV	2
Single-Ended Output Voltage		-0.3		4.0	V	

### Notes:

1. Connected directly to Tx data input pins. AC coupled thereafter.
2. Into 100Ω differential termination.

## Optical Characteristics

Parameter	Symbol	Min.	Typ.	Max.	Unit	Notes
<b>Transmitter</b>						
Center Wavelength	$\lambda_C$	840		860	nm	
Average Launch Power Per Lane		-8.4		2.4	dBm	
Spectral Width (RMS)	$\sigma$			0.6	nm	
Optical Extinction Ratio	ER	2			dB	
Optical Return Loss Tolerance	ORLT			12	dB	
Output Eye Mask	Compliant with IEEE 802.3bm					1
<b>Receiver</b>						
Receiver Wavelength	$\lambda$	840		860	nm	
Rx Sensitivity Per Lane	RSENS			-10.3	dBm	2
LOS De-Assert	LOSD	-30			dBm	
LOS Assert	LOSA			-12	dBm	
Input Saturation Power (Overload)	Psat	2.4			dBm	
Receiver Reflectance				-12	dB	

### Notes:

1. Hit ratio  $1.5 \cdot 10^{-5}$  hits per sample.
2. Measured with a PRBS  $2^{31}-1$  test pattern, @25.78Gbps, and  $BER < 5.0 \cdot 10^{-5}$ .

## Pin Descriptions

Pin	Logic	Symbol	Name/Descriptions	Ref.
1		GND	Module Ground.	1
2	CML-I	Tx2-	Transmitter Inverted Data Input.	
3	CML-I	Tx2+	Transmitter Non-Inverted Data Input.	
4		GND	Module Ground.	1
5	CML-I	Tx4-	Transmitter Inverted Data Input.	
6	CML-I	Tx4+	Transmitter Non-Inverted Data Input.	
7		GND	Module Ground.	1
8	LVTTTL-I	MODSEIL	Module Select.	2
9	LVTTTL-I	ResetL	Module Reset.	2
10		VccRx	+3.3V Receiver Power Supply.	
11	LVCNOS-I	SCL	2-Wire Serial Interface Clock.	2
12	LVCNOS-I/O	SDA	2-Wire Serial Interface Data.	2
13		GND	Module Ground.	1
14	CML-O	Rx3+	Receiver Non-Inverted Data Output.	
15	CML-O	Rx3-	Receiver Inverted Data Output.	
16		GND	Module Ground.	1
17	CML-O	Rx1+	Receiver Non-Inverted Data Output	
18	CML-O	Rx1-	Receiver Inverted Data Output.	
19		GND	Module Ground.	1
20		GND	Module Ground.	1
21	CML-O	Rx2-	Receiver Inverted Data Output.	
22	CML-O	Rx2+	Receiver Non-Inverted Data Output.	
23		GND	Module Ground.	1
24	CML-O	Rx4-	Receiver Inverted Data Output.	
25	CML-O	Rx4+	Receiver Non-Inverted Data Output.	
26		GND	Module Ground.	1
27	LVTTTL-O	ModPrsL	Module Present. Internally pulled down to GND.	
28	LVTTTL-O	IntL	Interrupt output should be pulled up on the host board.	2
29		VccTx	+3.3V Transmitter Power Supply.	
30		Vcc1	+3.3V Power Supply.	
31	LVTTTL-I	LPMODE	Low-Power Mode.	2
32		GND	Module Ground.	1
33	CML-I	Tx3+	Transmitter Non-Inverted Data Input.	
34	CML-I	Tx3-	Transmitter Inverted Data Input.	
35		GND	Module Ground.	1
36	CML-I	Tx1+	Transmitter Non-Inverted Data Input.	
37	CML-I	Tx1-	Transmitter Inverted Data Input.	
38		GND	Module Ground.	1

**Notes:**

1. Module circuit ground is isolated from module chassis ground within the module.
2. Open collector. Should be pulled up with 4.7kΩ-10kΩ on the host board to a voltage between 3.15V and 3.6V.

**Electrical Pin-Out Details**

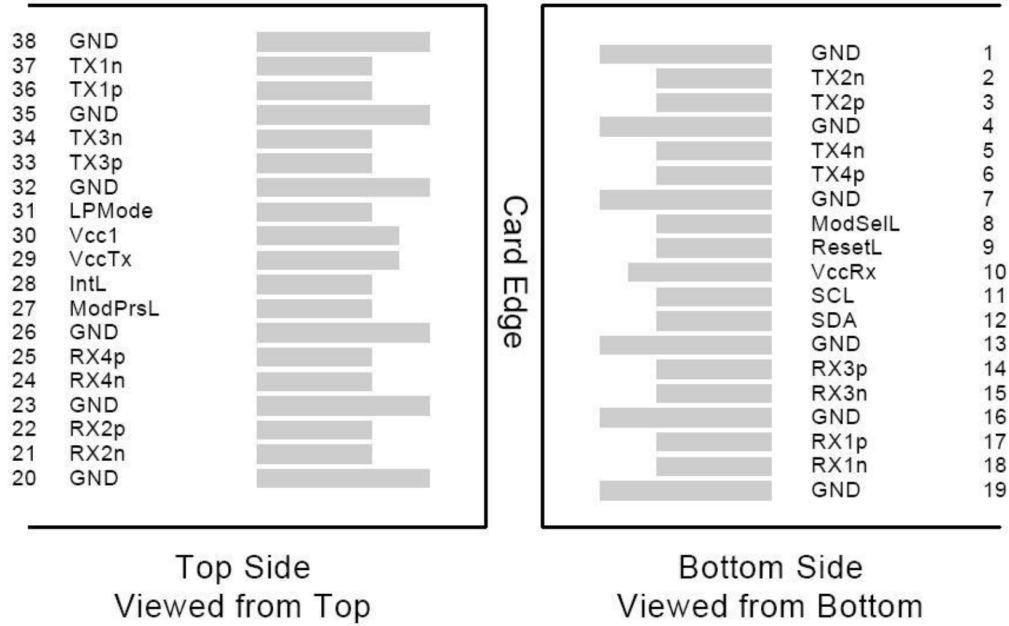

# Transceiver Interface Block Diagram

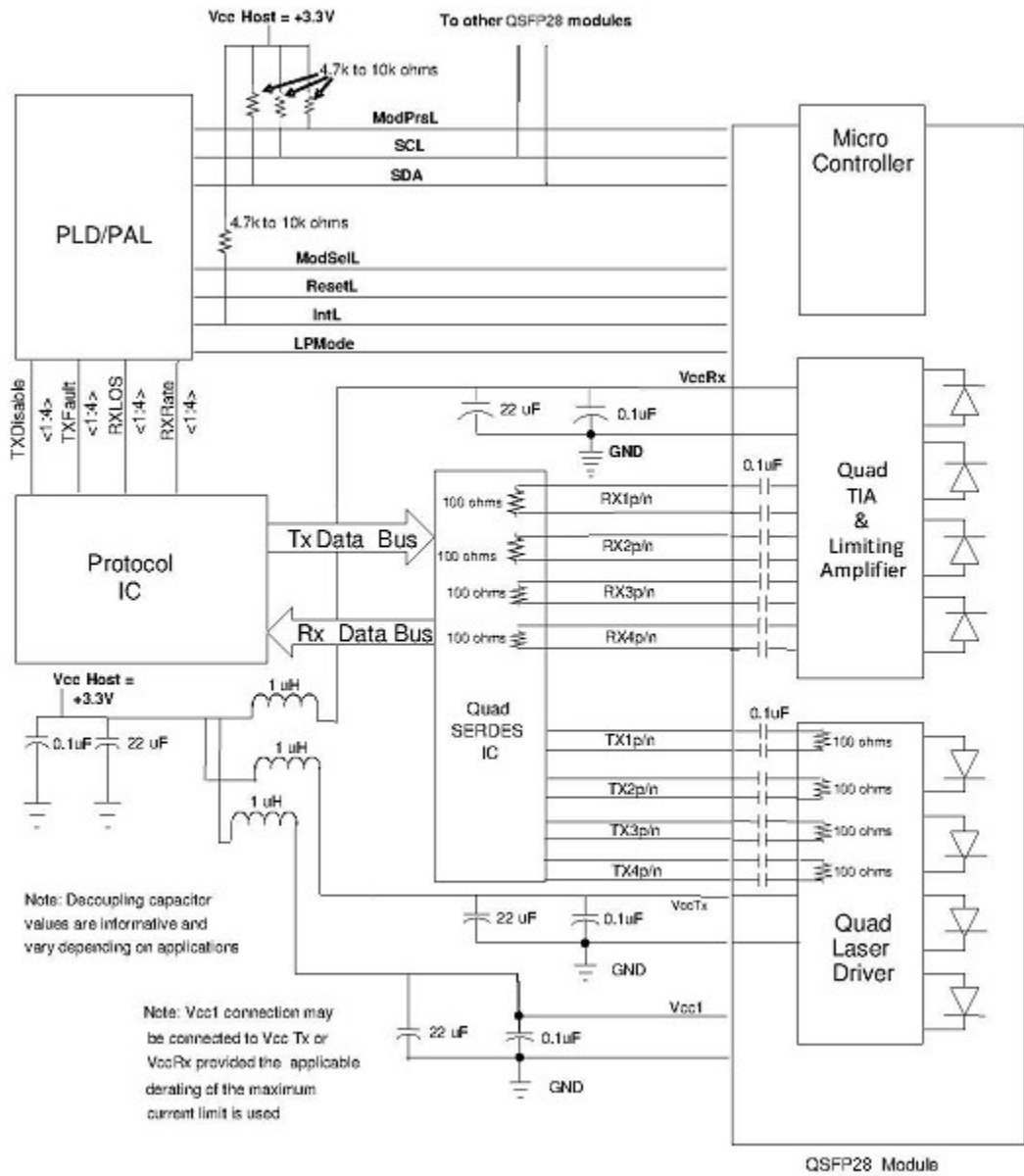

# Mechanical Specifications

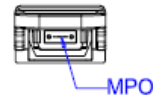
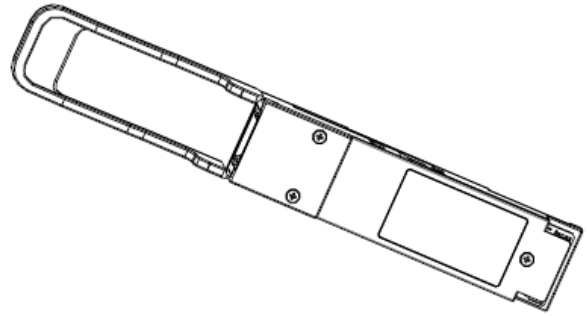
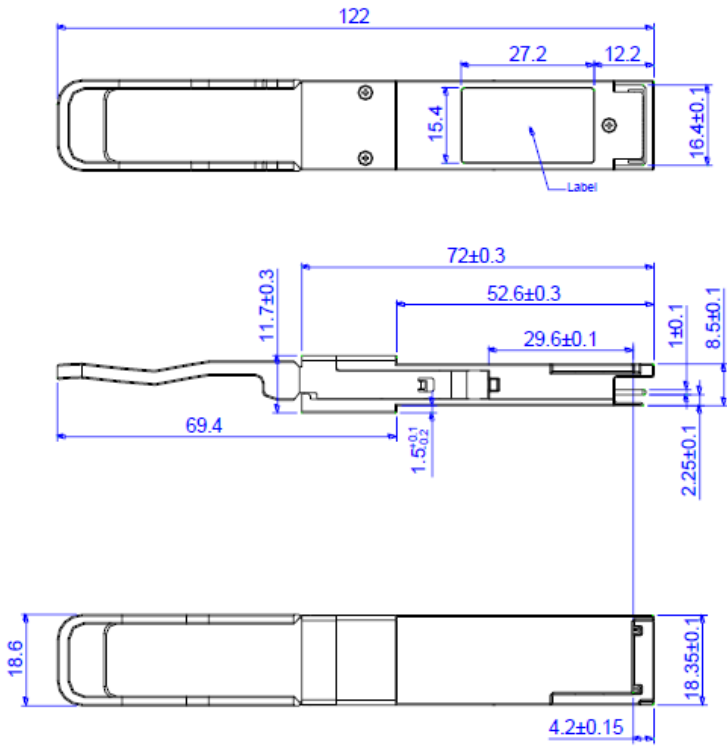

Units in mm

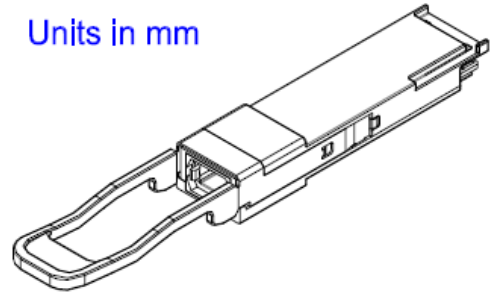

## About AddOn Networks

In 1999, AddOn Networks entered the market with a single product. Our founders fulfilled a severe shortage for compatible, cost-effective optical transceivers that compete at the same performance levels as leading OEM manufacturers. Adhering to the idea of redefining service and product quality not previously had in the fiber optic networking industry, AddOn invested resources in solution design, production, fulfillment, and global support.

Combining one of the most extensive and stringent testing processes in the industry, an exceptional free tech support center, and a consistent roll-out of innovative technologies, AddOn has continually set industry standards of quality and reliability throughout its history.

Reliability is the cornerstone of any optical fiber network and is engrained in AddOn's DNA. It has played a key role in nurturing the long-term relationships developed over the years with customers. AddOn remains committed to exceeding industry standards with certifications from ranging from NEBS Level 3 to ISO 9001:2005 with every new development while maintaining the signature reliability of its products.



## U.S. Headquarters

Email: [sales@addonnetworks.com](mailto:sales@addonnetworks.com)

Telephone: +1 877.292.1701

Fax: 949.266.9273

## Europe Headquarters

Email: [salesupportemea@addonnetworks.com](mailto:salesupportemea@addonnetworks.com)

Telephone: +44 1285 842070