

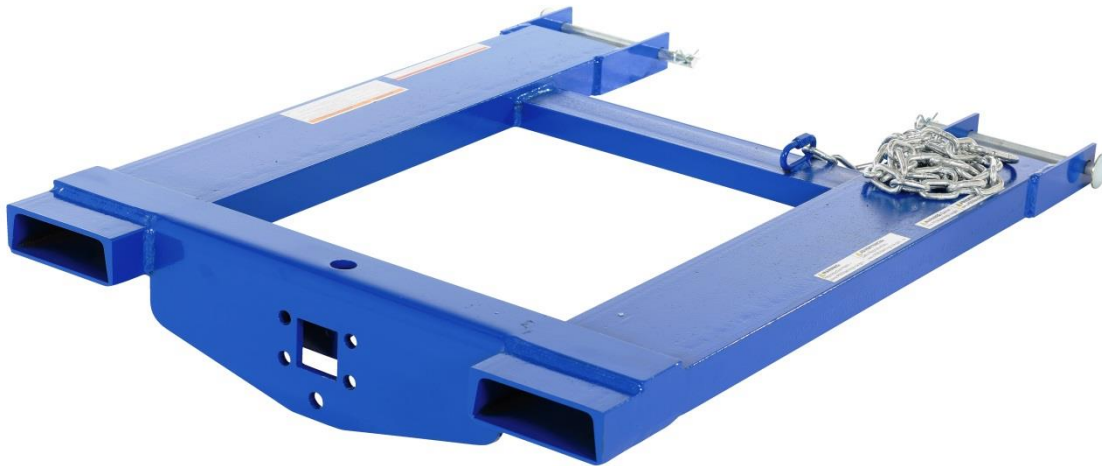

Vestil Manufacturing Company

2999 North Wayne Street, P.O. Box 507, Angola, IN 46703
 Telephone: (260) 665-7586 -or- Toll Free (800) 348-0868
 Fax: (260) 665-1339
 Web: www.vestil.com e-mail: info@vestil.com

HOOK-BASE



Receiving Instructions

After delivery, remove the packaging from the product. Inspect the product closely to determine whether it sustained damage during transport. If damage is discovered, record a complete description of it on the bill of lading. If the product is undamaged, discard the packaging.

NOTE: The end-user is solely responsible for confirming that product design, use, and maintenance comply with laws, regulations, codes, and mandatory standards applied where the product is used.

Technical Service & Replacement Parts

For answers to questions not addressed in these instructions and to order replacement parts, labels, and accessories, call our Technical Service and Parts Department at (260) 665-7586. The department can also be contacted online at <https://www.vestil.com/page-parts-request.php>.

Electronic copies of Instruction Manuals

Additional copies of this instruction manual may be downloaded from <https://www.vestil.com/page-manuals.php>.

Table of Contents		Page
Signal Words.....		2
Safety Instructions.....		2
Specifications.....		3, 4, 5
National Standards.....		5
Exploded View & Bill of materials.....		6
Using the HOOK-BASE.....		6, 7, 8
Record of Satisfactory Condition.....		9
Inspections & Maintenance.....		9
Labeling Diagram.....		10
Limited Warranty.....		11

SIGNAL WORDS

This manual uses SIGNAL WORDS to indicate the likelihood of personal injuries, as well as the probable seriousness of those injuries, if the product is misused in the ways described. Other signal words call attention to uses of the product likely cause property damage. The following are signal words used in this manual and their definitions.

⚠ DANGER

Identifies a hazardous situation which, if not avoided, **WILL** result in **DEATH** or **SERIOUS INJURY**. Use of this signal word is limited to the most extreme situations.

⚠ WARNING

Identifies a hazardous situation which, if not avoided, **COULD** result in **DEATH** or **SERIOUS INJURY**.

⚠ CAUTION

Indicates a hazardous situation which, if not avoided, **COULD** result in **MINOR** or **MODERATE** injury.

NOTICE

Identifies practices likely to result in product/property damage, such as operation that might damage the product.

SAFETY INSTRUCTIONS

Vestil strives to identify foreseeable hazards associated with the use of its products. However, no manual can address every conceivable risk. Minimize the likelihood of injury by observing the hazards identified below and by inspecting and maintaining the product as instructed in [INSPECTIONS & MAINTENANCE](#) on p. 9.



WARNING

Risks of serious personal injuries or death.

- **Read this manual in its entirety before assembling, installing, using, inspecting or servicing the product.** A copy of this manual should always be available to all persons who assemble, install, use, inspect, or maintain this device.
- DO NOT exceed the 4,000 lb. (1,818.2kg) capacity/maximum rated load. See Label 1153 on product; also see [LABELING DIAGRAM](#) on p. 10.
- Inspect the product before each use as directed in [INSPECTIONS & MAINTENANCE](#) on p. 9. DO NOT use the HOOK-BASE unless it is in satisfactory condition.
- Before attaching the HOOK-BASE to the coupler of a towable item, inspect the coupler and latch. Confirm that all parts are in satisfactory condition. DO NOT use the HOOK-BASE to tow equipment UNLESS the coupler seats onto the correct ball hitch and latches properly.
- **Do not use the HOOK-BASE to pull loads of more than 2,500 pounds. Trailer + load must be 2,500lb. or less.**
- ONLY transport loads with the HOOK-BASE attachment across level surfaces.
- Whenever using the load hook, always test the soundness of the connection between the hook and the suspended load *before* transporting the load. Lift the load a few inches above the ground. Load swing should be minimal and the load should not shift. If the load is not stable while suspended, return it to the ground and adjust the load rigging. Use this HOOK-BASE consistently with the fork truck training you received.
- Minimize load swing. Position the lifting hook directly above the center of the top of the load; then attach the load to the hook with appropriate rigging and slowly raise the load.
- DO NOT remove or obscure any label.
- Verify the placement and legibility of all labels shown in the [LABELING DIAGRAM](#) on p. 10. DO NOT use this device UNLESS all product labels are easily readable and undamaged.
- DO NOT ride, or sit, on the HOOK-BASE. DO NOT use the HOOK-BASE to tow items carrying people.
- DO NOT use the lifting hook to lift any apparatus that supports people, such as a work platform.
- DO NOT leave towed equipment attached to the HOOK-BASE. Immobilize the equipment (e.g. with wheel chocks) and disengage it from the towing attachment.
- DO NOT leave suspended loads unattended. Always disengage any load suspended from the lifting hook before leaving it unattended.
- DO NOT modify the HOOK-BASE without written approval from Vestil. **Unapproved modifications automatically void the [LIMITED WARRANTY \(p. 11\)](#) and might make the HOOK-BASE unsafe to use.**
- ONLY raise the forks as high as necessary to put the trailer in a horizontal (level) position for towing.
- If using the hoist hook attachment to lift loads, only raise the forks as high as necessary to raise the load off of the ground and to avoid contact with objects in the path of travel.
- DO NOT use the HOOK-BASE to transport *anything* but trailers or equipment designed to be towed. The towing attachment (hitch ball or pintle hook) must match the towing adapter on the towed equipment.

SPECIFICATIONS

Dimensions and other specifications of each standard model HOOK-BASE appear in the diagrams and tables below and on pages 4 & 5.

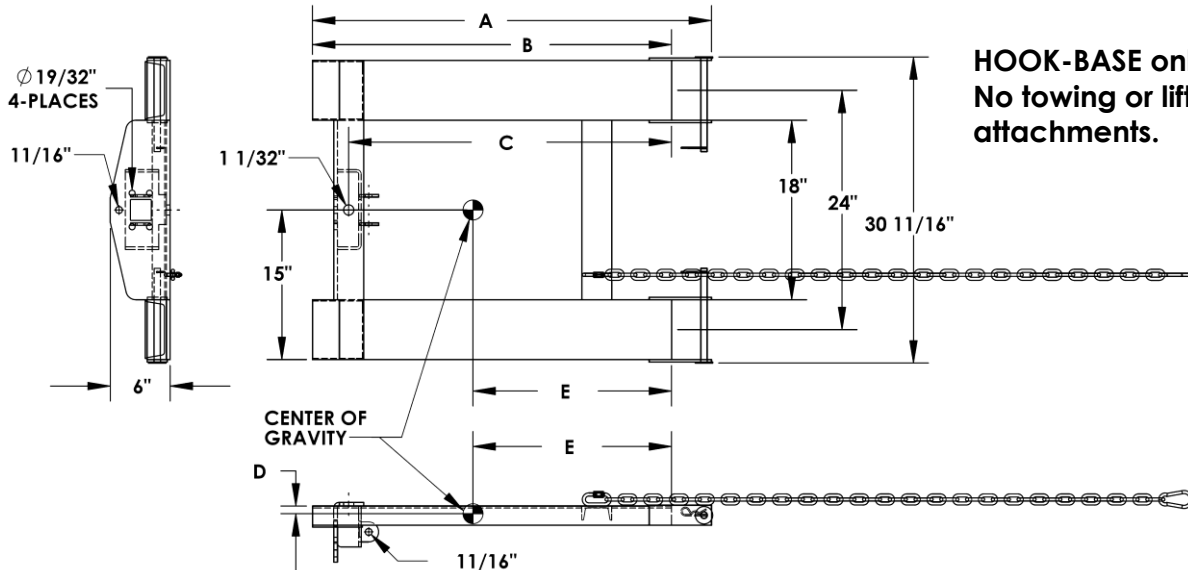

Model	A	B	C	D	E	Capacity	Net Weight
HOOK-BASE-32	40" 101.6cm	36" 91.4cm	32 ³ / ₈ " 82.2cm	0.77" 2.0cm	19.91" 50.6cm	4,000 lb. 1,818.2kg	88 lb. (40kg)
HOOK-BASE-38	46" 116.8cm	42" 106.7cm	38 ³ / ₈ " 97.5cm	0.74" 1.9cm	23.08" 58.6cm	4,000 lb. 1,818.2kg	96 lb. (43.6 kg)
HOOK-BASE-44	52" 132.1cm	48" 121.9cm	44 ³ / ₈ " 112.7cm	0.72" 1.8cm	26.23" 66.6cm	4,000 lb. 1,818.2kg	105 lb. (47.7 kg)

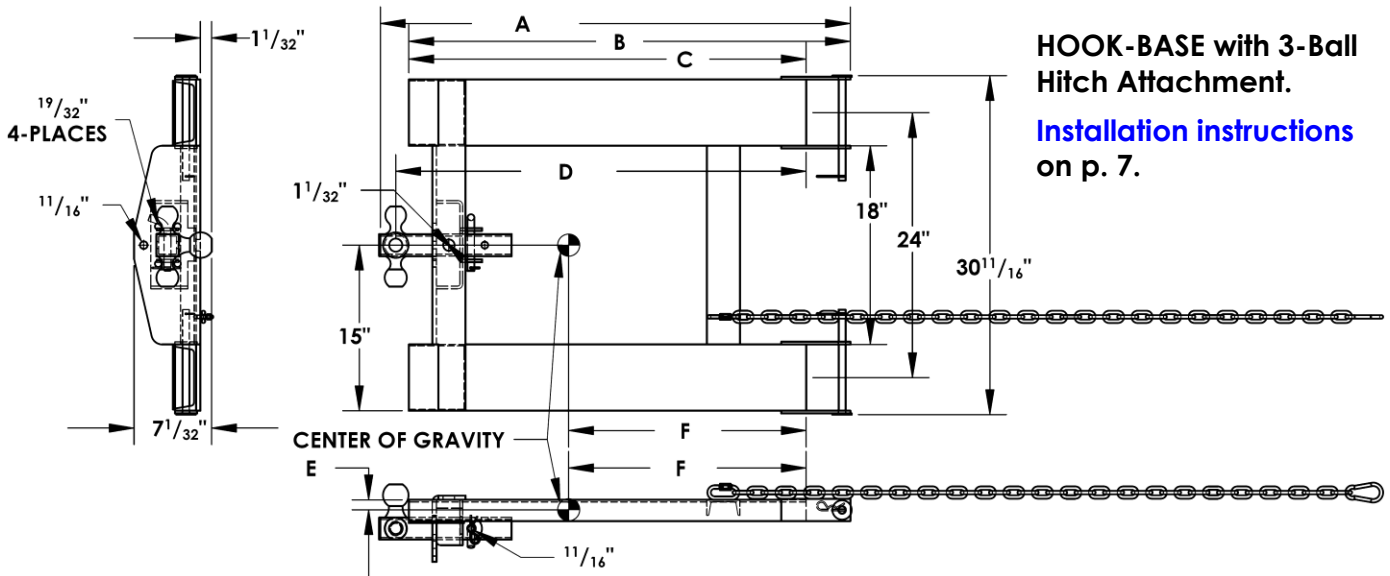

Model	A	B	C	D	E	F	Capacity	Net Weight
HOOK-BASE-32	42 ¹⁹ / ₃₂ " 108.2cm	40" 101.6cm	36" 91.4cm	37 ³ / ₁₆ " 94.5cm	0.90" 2.3cm	21.52" 54.0cm	4,000 lb. 1,818.2kg	98 lb. (44.5 kg)
HOOK-BASE-38	48 ¹⁹ / ₃₂ " 123.4cm	46" 116.8cm	42" 106.7cm	43 ³ / ₁₆ " 109.7cm	0.87" 2.2cm	24.85" 63.1cm	4,000 lb. 1,818.2kg	106 lb. (48.2 kg)
HOOK-BASE-44	54 ¹⁹ / ₃₂ " 138.7cm	52" 132.1cm	48" 121.9cm	49 ³ / ₁₆ " 124.9cm	0.86" 2.2cm	28.12" 71.4cm	4,000 lb. 1,818.2kg	114 lb. (51.8 kg)

SPECIFICATIONS (CONTINUED)

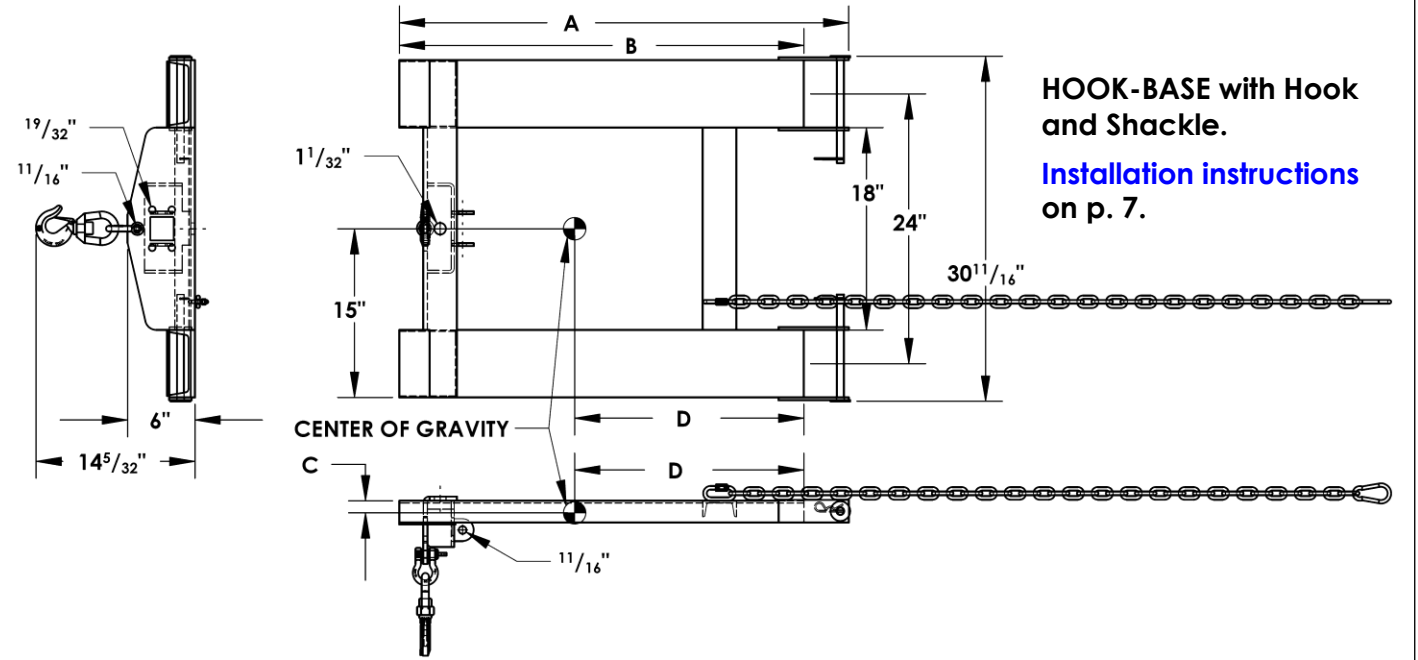

Model	A	B	C	D	Capacity	Net Weight
HOOK-BASE-32	40" 101.6cm	36" 91.4cm	1.07" 2.7cm	20.40" 51.8cm	4,000 lb. 1,818.2kg	91 lb. (41.4kg)
HOOK-BASE-38	46" 116.8cm	42" 106.7cm	1.02" 2.6cm	23.62" 60.0cm	4,000 lb. 1,818.2kg	99 lb. (45 kg)
HOOK-BASE-44	52" 132.1cm	48" 121.9cm	0.99" 2.5cm	26.81" 668.1cm	4,000 lb. 1,818.2kg	108 lb. (49.1 kg)

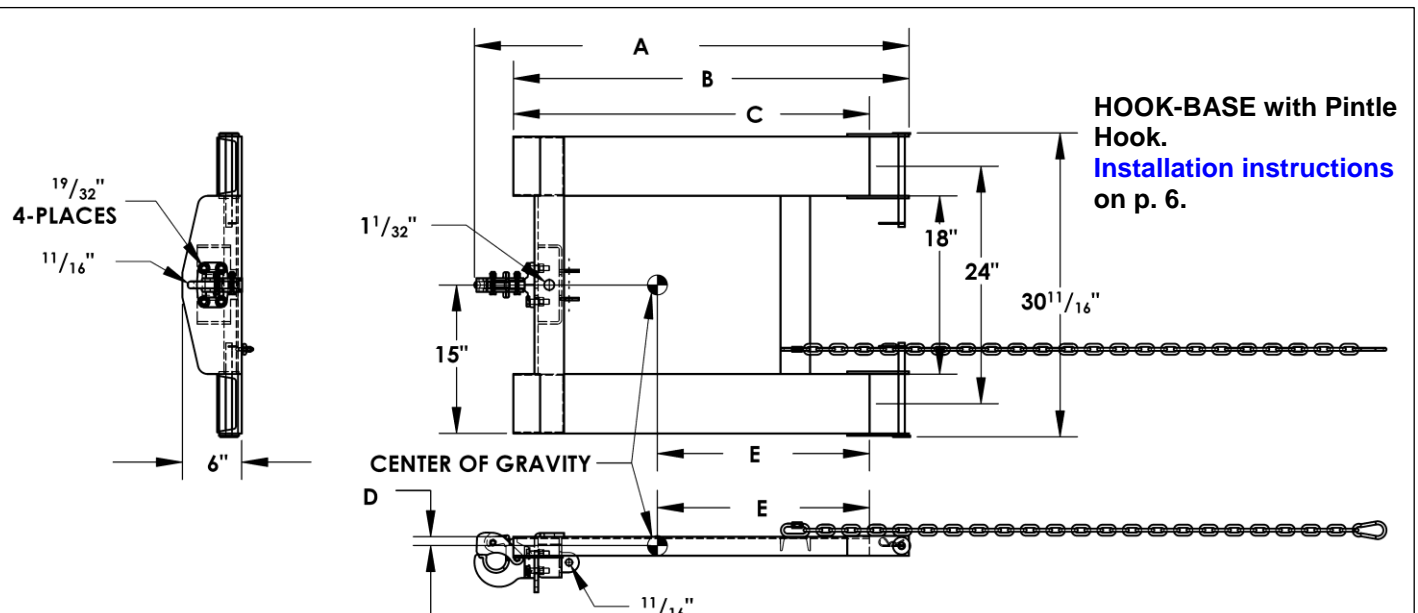

Model	A	B	C	D	E	Capacity	Net Weight
HOOK-BASE-32	43 15/16" 111.6cm	40" 101.6cm	36" 91.4cm	0.90" 2.3cm	21.44" 54.5cm	4,000 lb. 1,818.2kg	97 lb. (44.1 kg)
HOOK-BASE-38	49 15/16" 126.8cm	46" 116.8cm	42" 106.7cm	0.87" 2.2cm	24.71" 62.8cm	4,000 lb. 1,818.2kg	105 lb. (47.7 kg)
HOOK-BASE-44	55 15/16" 142.1cm	52" 132.1cm	48" 121.9cm	0.84" 2.1cm	27.96" 71.0cm	4,000 lb. 1,818.2kg	113 lb. (51.4 kg)

SPECIFICATIONS (CONTINUED)

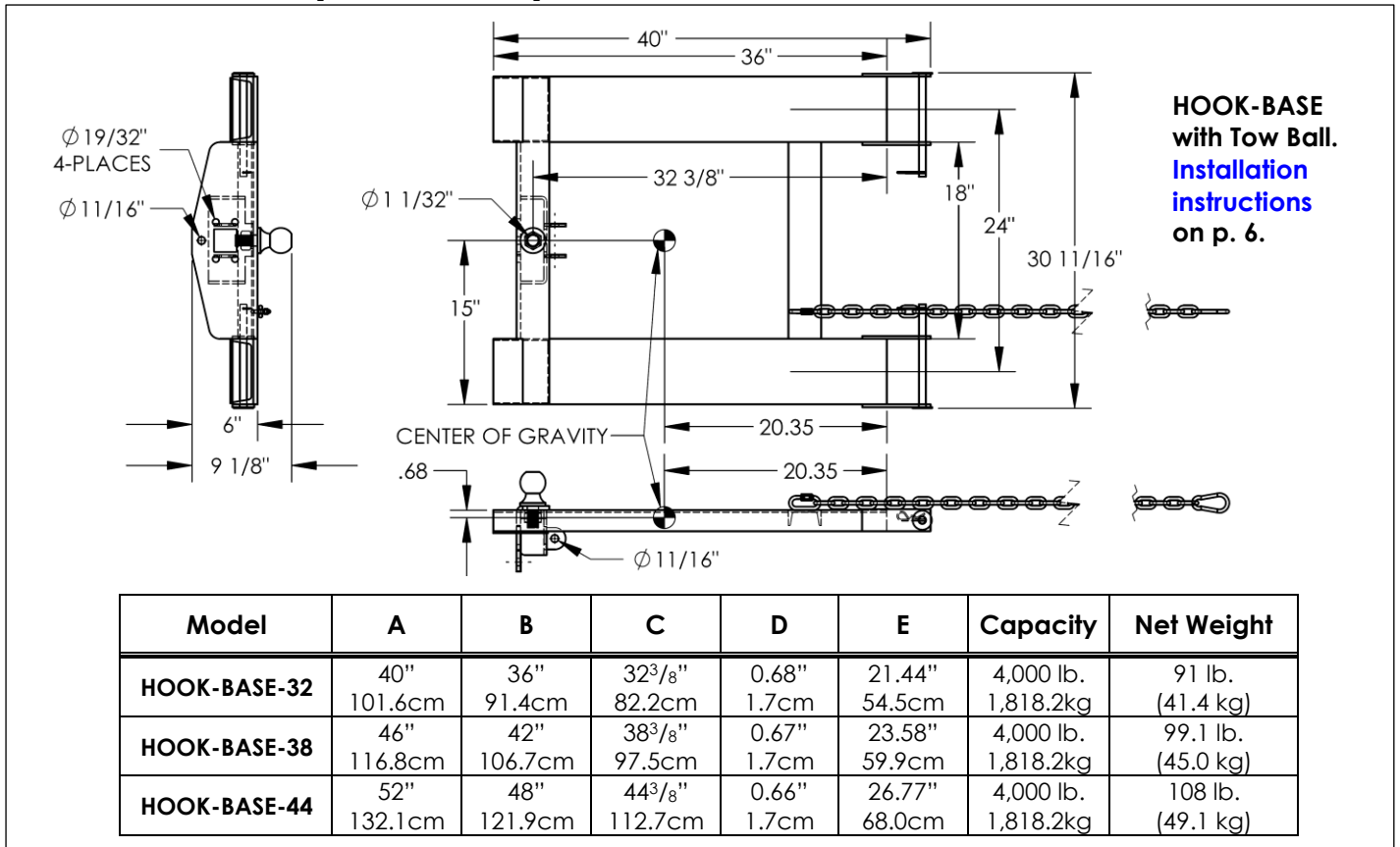

HITCH ATTACHMENTS

Ball Hitches	Ball Diameter	Shank Diameter	Capacity	Net Weight
BALL-178	1 ⁷ / ₈ " (4.8cm)	1" (2.5cm)	2,000 lb. (909.1kg)	3 lb. (1.4kg)
BALL-200	2" (5.1cm)	1" (2.5cm)	5,000 lb. (2272.7kg)	3 lb. (1.4kg)
BALL-2516	2 ⁵ / ₁₆ " (5.9cm)	1" (2.5cm)	5,000 lb. (2272.7kg)	4 lb. (1.8kg)
HITCH-3B	1 ⁷ / ₈ ", 2", & 2 ⁵ / ₁₆ " (4.8cm; 5.1cm; 5.9cm)	N/A (hitches permanently mounted to 2"x2"x12" square tube)	2,000 lb. (909.1kg) 3,500 lb. (1590.9kg) 7,500 lb. (3409.1kg)	12 lb. (5.5kg)

Model	Jaw Opening	Vertical Capacity	Uniform Trailer Capacity	Net Weight
PINTLE Use with 3" (inner diameter) pintle ring	1 ³ / ₄ " (~4 ¹ / ₂ cm)	2,000 lb. (909.1kg)	10,000 lb. (4545.5kg)	12 lb. (4.7kg)

NATIONAL STANDARDS

US (federal) OSHA Rule 1910.178 (29 CFR 1910.178; the "Rule") classifies this device as a front end attachment whenever it is mounted on a lift truck. The Rule incorporates American National Standard ANSI/ITSDF B56.1 (the "Standard"). The Standard is published by the Industrial Truck Standards Development Foundation on its website (www.itsdf.org) where it is freely downloadable at <http://www.itsdf.org/cue/b56-standards.html>. Before putting this device into service, you must acquire a copy of the Standard. Apply all relevant parts of Part II: For the User. If instructions provided in this manual conflict with the Standard, then you should apply the instructions in the Standard. Vestil requests that you immediately share any conflicts with its [TECHNICAL SERVICE](#) personnel. Contact information for the [TECHNICAL SERVICE](#) department appears on the cover page of this manual.

EXPLODED VIEW AND BILL OF MATERIALS

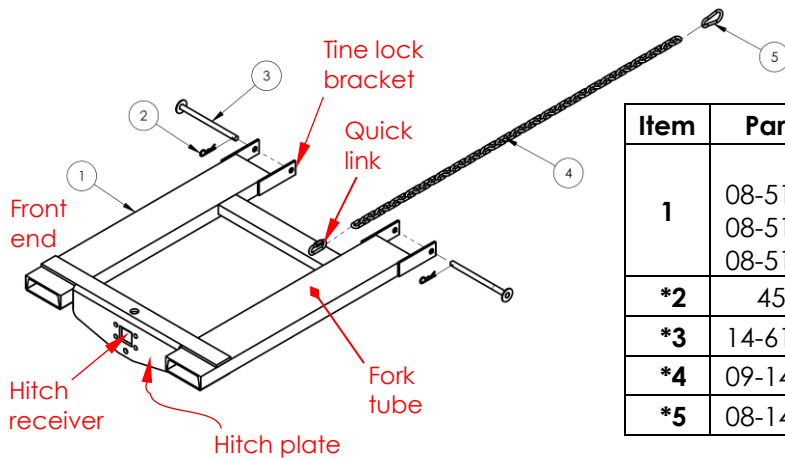

* COMBINED INTO HARDWARE KIT
08-154-006

Item	Part no.	Description	Qty.
1	08-514-140	Frame weldment:	1
	08-514-139	HOOK-BASE-32	1
	08-514-102	HOOK-BASE-38	1
*2	45286	HOOK-BASE-42	1
*3	14-612-001	#11 hitch pin clip, 1/8" x 2 5/8"	2
*4	09-145-018	Pin, lock, weldment	2
*5	08-145-018	5/16" chain 56" long	1
	08-145-041	Snap hook, 5/16"	1

USING THE HOOK-BASE: Refer to the [EXPLODED VIEW](#) (above) to identify features.

⚠ WARNING

USING THIS (LIFT TRUCK) FRONT END ATTACHMENT AFFECTS THE CENTER OF GRAVITY OF YOUR LIFT TRUCK. BEFORE USING THIS DEVICE, US FEDERAL REGULATION [29 CFR 1910.178](#) REQUIRES YOU TO CONTACT THE MANUFACTURER OF YOUR LIFT TRUCK TO REQUEST:

- WRITTEN APPROVAL (29 CFR 1910.178(a)(4)); AND
- MARKINGS FOR THE LIFT TRUCK THAT IDENTIFY THE ATTACHMENT AND GIVE THE APPROXIMATE WEIGHT OF THE TRUCK AND ATTACHMENT AT MAXIMUM ELEVATION WITH A Laterally-Centered Load (29 CFR 1910.178(a)(5)). **DO NOT USE THIS DEVICE UNTIL YOUR LIFT TRUCK IS MARKED WITH CORRECTED CAPACITY TAGS. ONLY USE THIS DEVICE WITH LIFT TRUCKS THAT HAVE BEEN MARKED WITH CORRECTED CAPACITY TAGS.**

STEP 1: Select the appropriate towing attachment and install it.

PINTLE HOOK

A) Insert the bolts through the four bolt holes in the hitch plate (shown by dashed arrows).

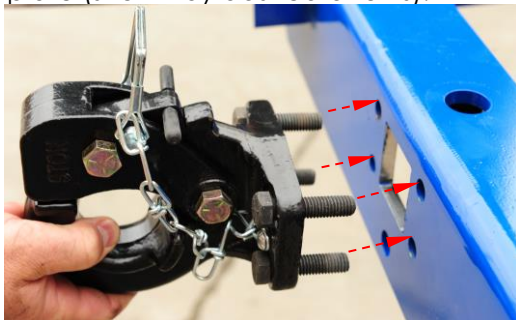

B) Fasten the pintle hook to the HOOK-BASE: first apply a lock washer to each bolt; then apply a hex nut. Fully tighten the nuts to secure the connections.



DO NOT PULL LOADS (TRAILER PLUS CONTENTS) WEIGHING MORE THAN 2,500 POUNDS.

TOW BALL

A) Insert the tow ball through the opening in the top of the hitch plate.

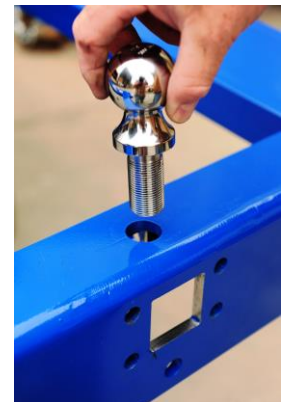

B) Fasten the tow ball to the HOOK-BASE: first apply a lock washer to each bolt; then apply a hex nut. Fully tighten the nuts to secure the connections.



DO NOT PULL LOADS WEIGHING MORE THAN 2,500 POUNDS.

3-BALL HITCH (model HITCH-3B)

Select the appropriate tow ball and insert the hitch through the (square) hitch receiver in the hitch plate with the selected tow ball facing upwards. See **EXPLODED VIEW** on p. 6. Align the pin holes in the hitch with the pin holes in the hitch brackets. Insert the lock pin through the pin holes and secure it in place with a hitch pin.

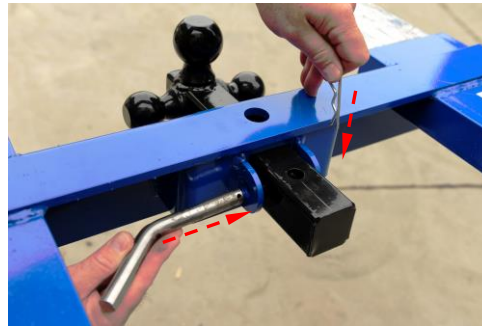

DO NOT PULL LOADS WEIGHING MORE THAN 2,500 POUNDS WITH THIS DEVICE!

HOOK AND SHACKLE (models HOOK-S-4 and HOOK-R-4)

Unscrew the shackle pin. Align the shackle with the bottom hole of the hitch plate and reattach the shackle pin

NOTE:
Swivel
hook
model
HOOK-
S-4
shown.

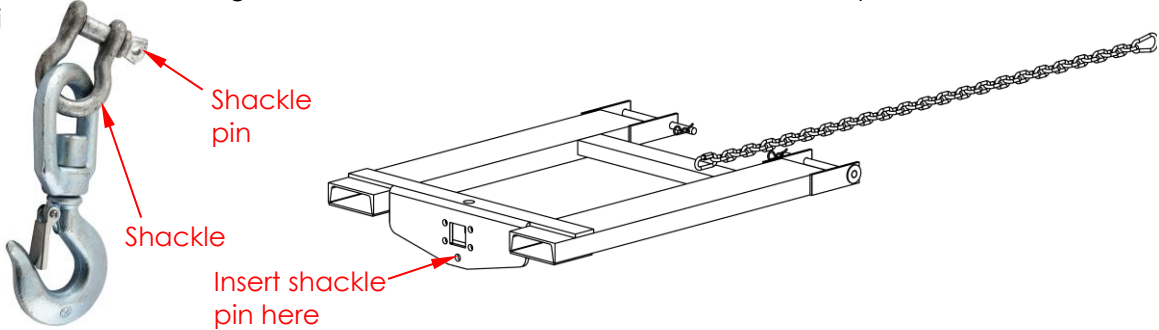

STEP 2: Remove locking pins from tine lock brackets. Adjust the positions of the forks of your lift truck to align with the fork tubes. Slowly drive the truck forward until the forks extend all the way through the fork pockets and the heels of the forks contact the ends of the fork tubes (the tine lock brackets should project behind the heels of the forks). Reinstall the locking pins; then reinstall the hitch pin clips.

NOTE: The forks of your lift truck should be **AT LEAST** as long as the fork tubes.

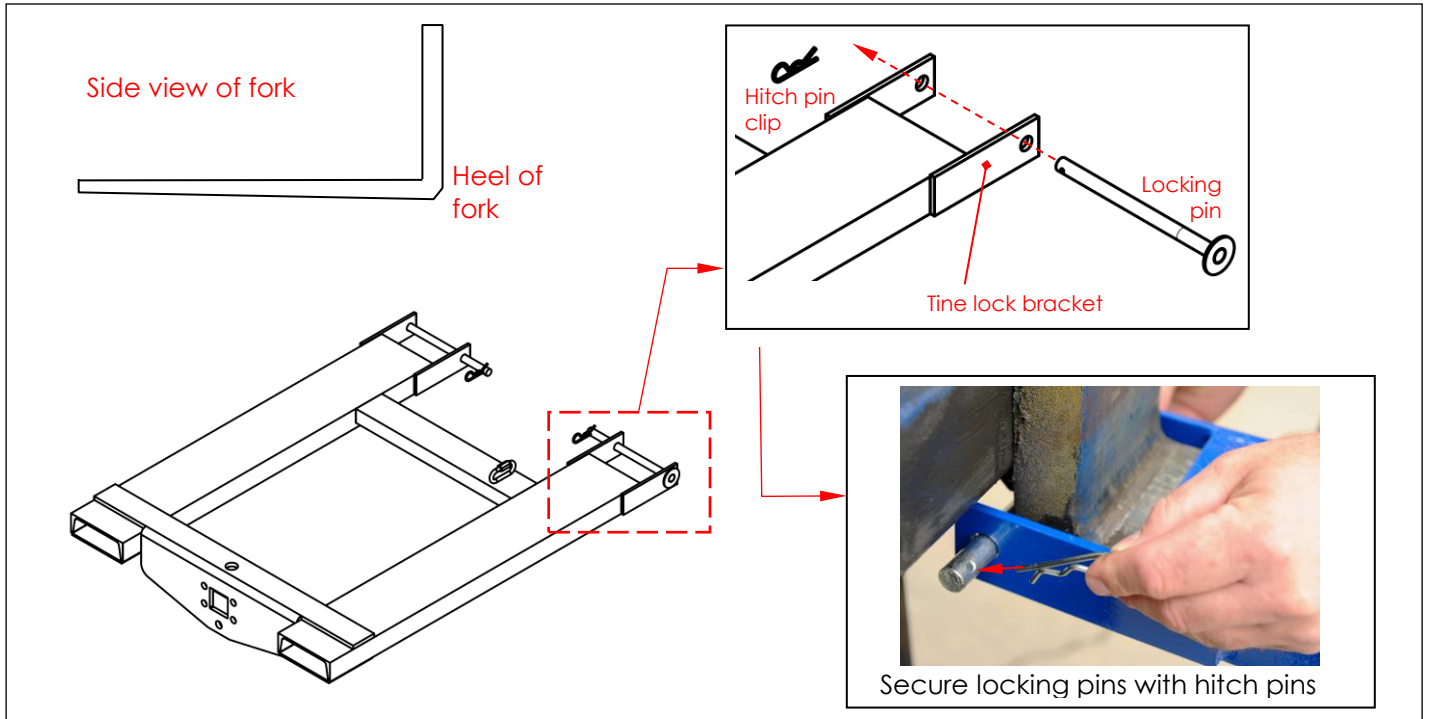

STEP 3: Fasten the safety chain to the carriage of the forklift **WITH NO SLACK**. Loop the safety chain around the carriage. Attach the snap hook at the end of the chain to the quick link (welded to the frame). Wrap the chain around the carriage as many times as is necessary to remove slack from the chain. The chain must not be able to disconnect from the carriage without deliberate effort.



The chain is an essential safety-enhancing feature. This photograph shows the safety chain wrapped around the forklift carriage and proper attachment of the snap hook to the quick link. In order to clearly show the connections, slack is left in the chain. However, there must be no slack in the chain whenever the HOOK-BASE is used. Wrap the chain around the carriage to remove all **slack**. Otherwise, the chain will not prevent the unit from sliding on the forks.

STEP 4: Connect the trailer or other item to be towed to the towing attachment. Raise the forks sufficiently to put the tongue of the trailer in a horizontal position.

To connect a trailer to the pintle hook attachment:

- a) Unlock the snapper pin and remove it from the upper jaw of the pintle hook;
- b) Open the jaws by pressing the upper jaw upwards, while also pressing the opening lever forward. The jaw will maintain the open position when the lever is pressed all the way forward.

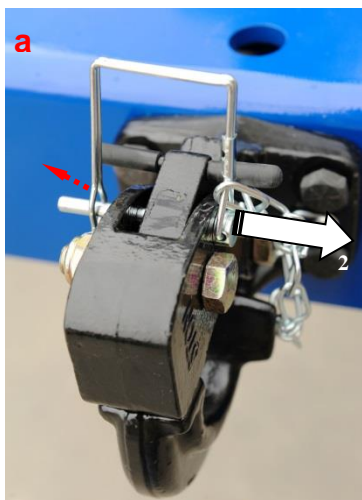

Unlock snapper pin and then pull the pin



Press upwards on upper jaw and press opening lever forward

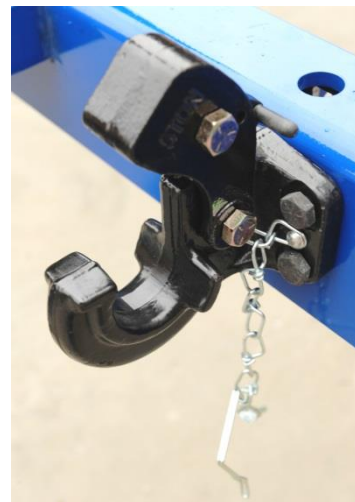

Pintle jaws open

RECORD OF SATISFACTORY CONDITION

When the unit is first unpacked, make a written record of its condition. Include observations about all features, i.e. pins, pin clips, welds, the frame, safety chain, quick link, and snap hook. Thoroughly photograph the unit and all labels applied to it. Add the photographs to the record. Describe where each label is located. This record establishes "satisfactory condition". During future inspections, compare your observations to the record to determine if the unit is in satisfactory condition. See [INSPECTIONS & MAINTENANCE](#) on p. 9.

INSPECTIONS & MAINTENANCE

NOTICE

Proper use, maintenance, and storage are essential for this product to function properly.

- Inspect the unit as instructed and at least as frequently as recommended.
- Use the product as recommended in the current revision of ANSI/ITSDF B56.1 and all instructions in this manual.
- Store the unit in a dry location.

Compare the results of each inspection to the [RECORD OF SATISFACTORY CONDITION](#) to determine whether the unit is in satisfactory condition. DO NOT use the HOOK-BASE unless it is in satisfactory condition. Only use manufacturer-approved replacement parts to restore the unit to satisfactory condition. Never make temporary repairs of damaged or missing parts. **DON'T GUESS! If you have any questions about the condition of your unit, contact the [TECHNICAL SERVICE](#) department.** The phone number is provided on the cover page of this manual. Purely cosmetic changes, such as chipped paint, are not changes from satisfactory condition. However, touchup paint should be applied to all areas where the finish is damaged as soon as the damage occurs because exposed metal rusts. Left unaddressed, rusting could compromise the soundness of the metal and create a safety hazard.

Inspect the following before each use:

1. Safety chain, quick link, and snap hook: Confirm that all parts of the safety chain are in satisfactory condition. The spring latch (of the snap hook) should automatically close and remain closed unless deliberately opened. Do not use the unit if the snap hook, chain, or quick link is damaged or worn.
2. Labeling: All labels should be easily readable and in place as shown in the [LABELING DIAGRAM](#). If a label is damaged, not easily readable, or missing, contact [TECHNICAL SERVICE](#) to order a replacement.

Inspect the following at least 1 time per month:

1. Fasteners (hardware):
 - Bolts, nuts, washers, pins, cotter pins, etc. If a lock nut is removed for any reason, it must be replaced with a new lock nut.
 - Safety chain assembly (chain, quick link, and snap hook). Confirm that each component is undamaged and operating normally.
2. Frame elements: Confirm that each fork tube is structurally sound and free of rust. The frame must be square and rigid. Look for bends, cracks, rust, and corrosion. Confirm that all welds are intact. Remove dirt and debris. Apply touchup paint to area where the finish is damaged.
3. Fork pockets: Confirm that each pocket is structurally sound and free of significant rust. Do not use the HOOK-BASE if the fork pockets are structurally compromised.
4. Welds: Confirm that all welds are intact. Only use this product if all welds are in satisfactory, undamaged condition.
5. Towing attachments, fork pockets, and hitch plate: Confirm satisfactory condition, i.e. no structural deformation, warps, or cracks, etc.

LABELING DIAGRAM

Label content and location are subject to change so your product might not be labeled exactly as shown. Compare the diagram below to your **RECORD OF SATISFACTORY CONDITION**. If differences between actual labeling and this diagram exist, contact **TECHNICAL SERVICE**. Replace all labels that are damaged, missing, or not easily readable (e.g. faded). To order replacement labels, or to inquire whether your unit is properly labeled, contact the technical service and parts department online at http://www.vestilmfg.com/parts_info.htm or by calling (260) 665-7586 and asking for the Parts Department.

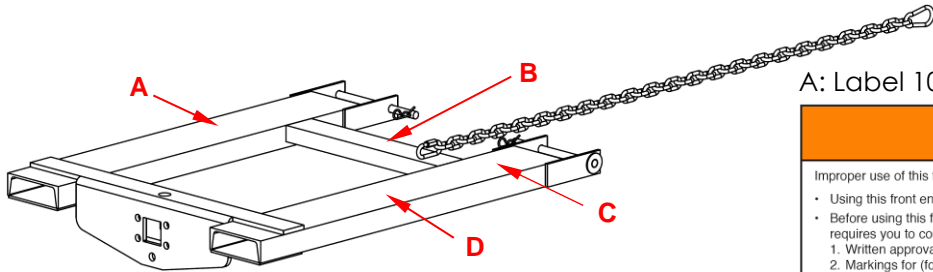

A: Label 1049

⚠ WARNING	
<p>Improper use of this fork attachment might result in death or serious injury.</p> <ul style="list-style-type: none"> Using this front end attachment affects lift truck center of gravity. Before using this fork attachment, US Federal regulation 29 CFR 1910.178 requires you to contact the manufacturer of your lift truck and request: <ol style="list-style-type: none"> Written approval [29 CFR 1910.178(a)(4)] Markings for (fork) lift truck that: <ul style="list-style-type: none"> Identify the attachment; Give approximate weight of truck and attachment at maximum elevation with laterally-centered load. [29 CFR 1910.178(a)(5)]. DO NOT use UNTIL lift truck is marked with corrected capacity tags. 1049 rev 1119 	

B: Label 1153

MODEL / MODÉLO / MODÈLE _____	
WEIGHT / PESO / MASS _____	
CAPACITY / CAPACIDAD / CAPACITÉ _____	
SERIAL / SERIE / SÉRIE _____	
UNITS: 2.2 lb. = 1kg 1" (or 1in.) = 2.54cm	1153

C: Label 218

⚠ WARNING	⚠ ADVERTENCIAS
<p>Improper use might result in death or serious personal injury. Attach device to fork carriage with safety chain/strap.</p> <ul style="list-style-type: none"> Drive lift truck forward until forks contact ends of fork pockets. Chain/straps must not be able to disconnect (slide free) from carriage. Safety chain/strap must be taut. Connect chain/strap to carriage via shortest line. 	<p>El uso impropio puede resultar en muerte o heridas personales. Atar aparato al mástil del montacargas con cadenas/correas.</p> <ul style="list-style-type: none"> Maneje el montacargas para adelante hasta que las cuñas hagan contacto con la orilla del bolsillo de las cuñas. La cadenas y correas no deben de deslizarse (soltarse) del mástil del montacargas. La cadena/correa de seguridad debe de estar apretado. Asegure la cadena/correa al mástil via la ruta mas corta. 218 rev 0910

D: Label 658

⚠ WARNING	⚠ ADVERTENCIA	⚠ AVERTISSEMENT
<p>Do not operate or move with unstable loads DO NOT LOAD beyond rated capacity DISTRIBUTE LOAD EVENLY DO NOT sit or ride</p>	<p>No use a mueva con cargas inestables No cargue mas de la capacidad tasada DISTRIBUYA LA CARGA A NIVEL NO SE SIENTE o vaya en el carro</p>	<p>Ne pas utiliser avec une charge instable NE PAS CHARGER au-delà du débit nominale DISTRIBUER la charge régulièrement NE PAS VOUS ASSEOIR OU VOUS PROMENER sur le chariot 658 rev 0908</p>



LIMITED WARRANTY

Vestil Manufacturing Corporation ("Vestil") warrants this product to be free of defects in material and workmanship during the warranty period. Our warranty obligation is to provide a replacement for a defective, original part covered by the warranty after we receive a proper request from the Warrantee (you) for warranty service.

Who may request service?

Only a warrantee may request service. You are a warrantee if you purchased the product from Vestil or from an authorized distributor AND Vestil has been fully paid.

Definition of "original part"?

An original part is a part used to make the product as shipped to the Warrantee.

What is a "proper request"?

A request for warranty service is proper if Vestil receives: 1) a photocopy of the Customer Invoice that displays the shipping date; AND 2) a written request for warranty service including your name and phone number. Send requests by one of the following methods:

<u>US Mail</u>	<u>Fax</u>	<u>Email</u>
Vestil Manufacturing Corporation	(260) 665-1339	info@vestil.com
2999 North Wayne Street, PO Box 507	<u>Phone</u>	Enter "Warranty service request"
Angola, IN 46703	(260) 665-7586	in subject field.

In the written request, list the parts believed to be defective and include the address where replacements should be delivered. After Vestil receives your request for warranty service, an authorized representative will contact you to determine whether your claim is covered by the warranty. Before providing warranty service, Vestil will require you to send the entire product, or just the defective part (or parts), to its facility in Angola, IN.

What is covered under the warranty?

The warranty covers defects in the following original, dynamic parts: motors, hydraulic pumps, motor controllers, and cylinders. It also covers defects in original parts that wear under normal usage conditions ("wearing parts"), such as bearings, hoses, wheels, seals, brushes, and batteries.

How long is the warranty period?

The warranty period for original dynamic components is 90 days. For wearing parts, the warranty period is 90 days. Both warranty periods begin on the date Vestil ships the product to the Warrantee. If the product was purchased from an authorized distributor, the periods begin when the distributor ships the product. Vestil may, at its sole discretion, extend a warranty period for products shipped from authorized distributors by up to 30 days to account for shipping time.

If a defective part is covered by the warranty, what will Vestil do to correct the problem?

Vestil will provide an appropriate replacement for any covered part. An authorized representative of Vestil will contact you to discuss your claim.

What is not covered by the warranty?

The Warrantee (you) is responsible for paying labor costs and freight costs to return the product to Vestil for warranty service.

Events that automatically void this Limited Warranty.

- Misuse;
- Negligent assembly, installation, operation or repair;
- Installation/use in corrosive environments;
- Inadequate or improper maintenance;
- Damage sustained during shipping;
- Collisions or other accidents that damage the product;
- Unauthorized modifications: Do not modify the product IN ANY WAY without first receiving written authorization from Vestil.

Do any other warranties apply to the product?

Vestil Manufacturing Corp. makes no other express warranties. All implied warranties are disclaimed to the extent allowed by law. Any implied warranty not disclaimed is limited in scope to the terms of this Limited Warranty. Vestil makes no warranty or representation that this product complies with any state or local design, performance, or safety code or standard. Noncompliance with any such code or standard is not a defect in material or workmanship.