

Parts List and Diagram

Part	Description	Qty.
1	Bottom Shelf	1
2	Wheel 6"	2
3	Swivel Caster	2
4	Vertical Support Panel	1
5	Center Shelf	1
6	Top Shelf	1

Part	Description	Qty.
7a	Left Support	1
7b	Right Support	1
8	Hook	2
9	Axle	1
10	Bolts, Washers, Nuts (set)	35
11	Flat Washers, Cotter Pin (set)	2
12	Chain	2

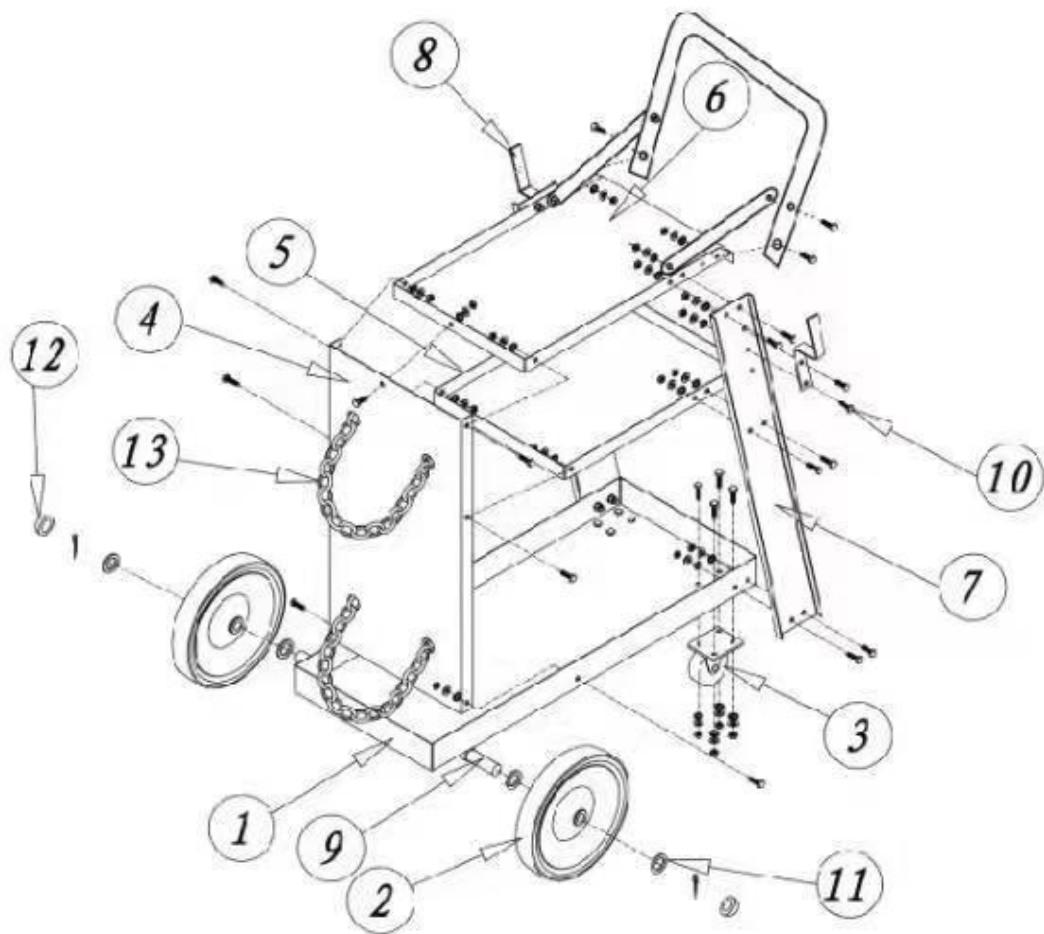

DULUXE 4 DRAWER CART

Parts List and Diagram

Part	Description	Qty
1	Bottom Shelf Asm.	1
2	Wheel	2
3	Swivel Caster	2
4	Back Panel	1
5	Middle Shelf	1
6	Top Shelf	1
7a	Left Support	1
7b	Right Support (not shown)	1
8	Hook	2

Part	Description	Qty
9	Axle	1
10	Boit, Washer, Nut (set) M6x12	31
11	Flat Washer	2
12	CotterPin	2
13	Chain	2
14	Drawer	4
15a	Left Plate	1
15b	Right Plate (not shown)	1

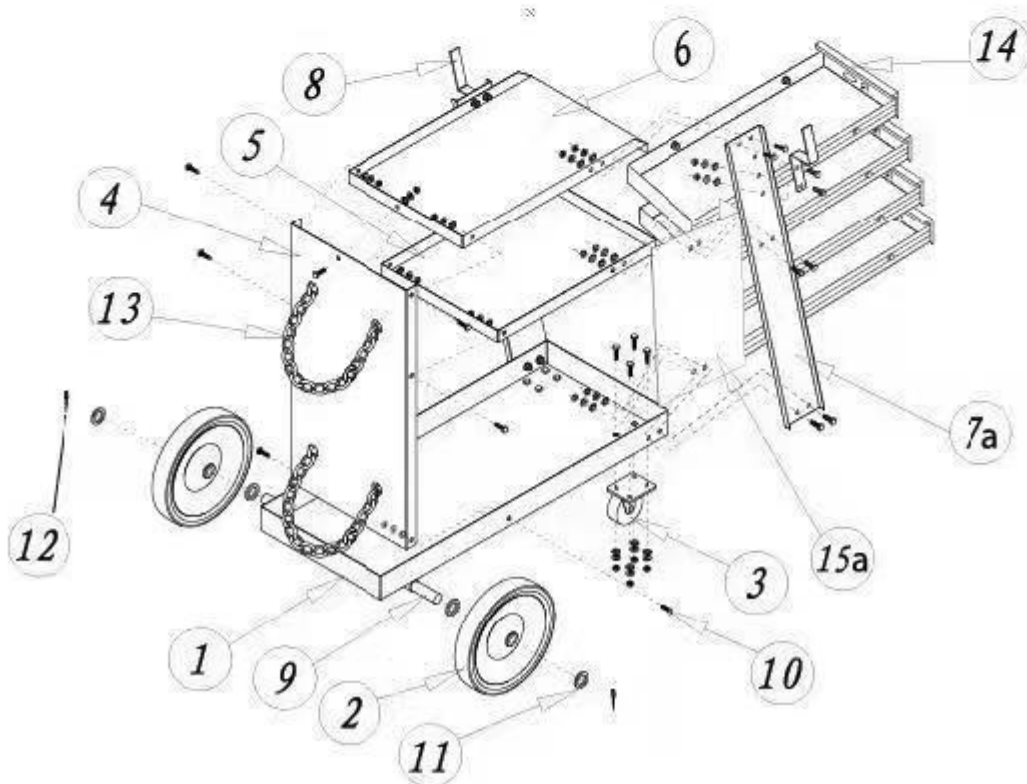

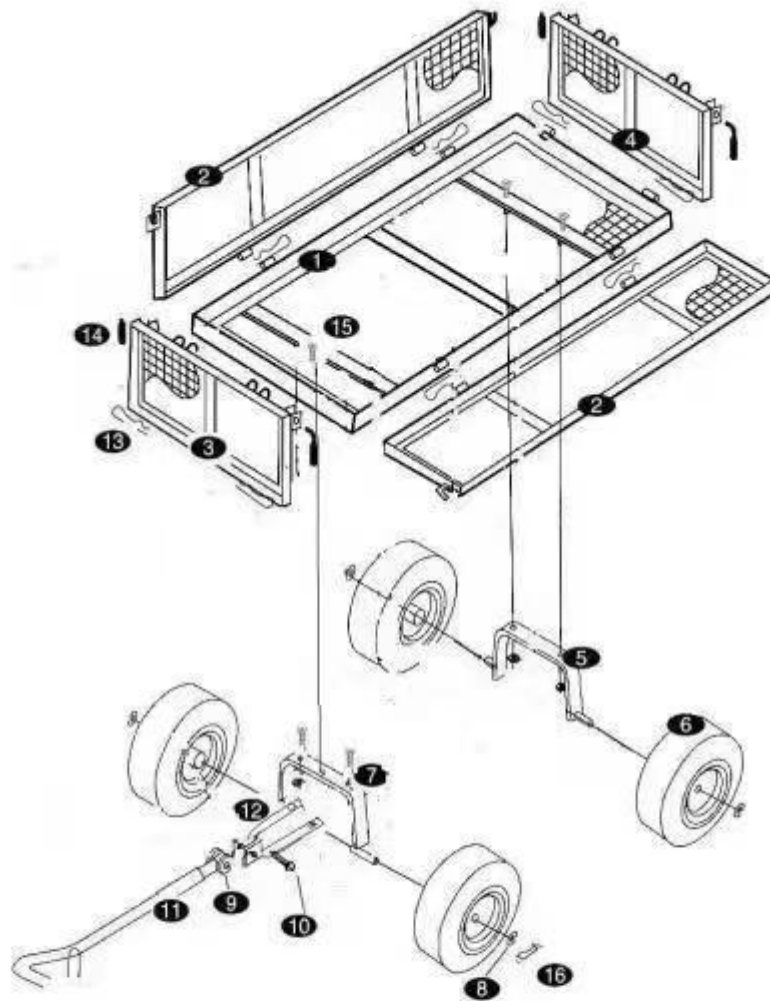

- | | |
|---------------------------------|----------------------------------|
| 1 Bed-(1) | 10 Bolts $\Phi 8 \times 60$ -(1) |
| 2 Sides-(2) | 11 Pull Handle-(1) |
| 3 Front-(1) | 12 Yoke-(1) |
| 4 Back-(1) | 13 Big B Clip-(8) |
| 5 Rear Axle Support-(1) | 14 Lock Handle-(4) |
| 6 Wheels 10x3,50 -4(4) | 15 Nuts w/Lock Inserts M12-(5) |
| 7 Front Axle Support-(1) | 16 R Clip-(4) |
| 8 Circle Cushion $\Phi 16$ -(4) | |
| 9 Plastic-(1) | |