



ITEM: TL-AZ600

TWO PIECE TOILET  
INSTALLATION & OPERATION MANUAL

V1.0

08/15/2025

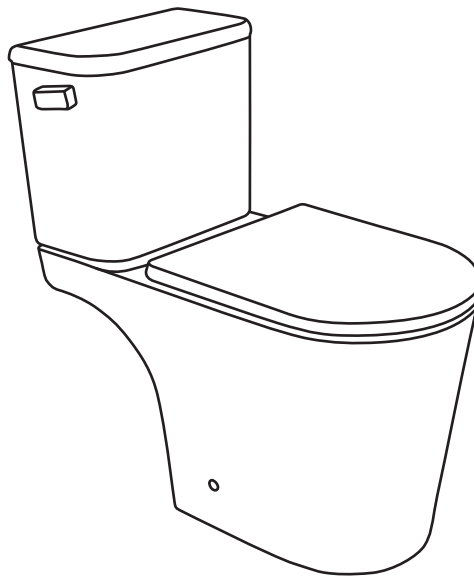

**DON'T WAIT!  
REGISTER NOW!**

Register your product within 90 days to ensure it is recognized as a purchase and covered under warranty.

Register online at <https://anzz.com/pages/register>  
or scan the QR code on PG. 2.



## PRODUCT REGISTRATION\*

**IMPORTANT:** Warranty will not be recognized unless product is registered.

Register online at <https://anzzi.com/pages/register> or Scan the QR code below.  
Registering your product maximizes your warranty benefits and ensures prompt service and support.

1

USE YOUR PHONE CAMERA  
TO SCAN THE QR CODE

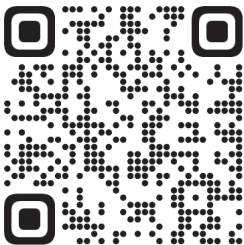

2

FILL IN A QUICK  
REGISTRATION FORM

Thank you for your purchase!

Registering your products ensures you maximize your warranty benefits and receive prompt service and support.

Name\*

Email\*

City\*

Order #\*

Installer Name

⋮

Model Purchased\*

Installer Phone Number

Customer Age Range

Submit

3

CLICK SUBMIT AND  
ENJOY PEACE OF MIND

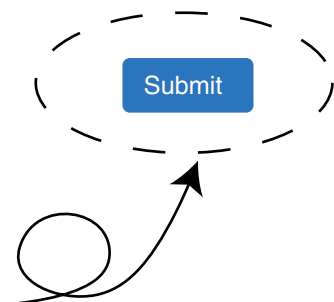

Need help? For technical support call 305-614-4070 or visit us at [www.ANZZI.com](http://www.ANZZI.com)

# INSTALLATION GUIDE

## BEFORE YOU BEGIN

- Carefully inspect the product for any damage or missing components upon delivery. Any issues must be reported immediately, as later claims may not be covered under warranty. Handle the toilet with care—avoid impacts to the sides and edges.
- Check with your local plumbing and building authorities to ensure compliance with applicable codes before installation.

### **WARNING**

- This toilet is made from vitreous china, a fragile, glass-like material with sharp edges when broken. Handle with care. Do not drop, overtighten bolts, or subject the toilet to rough handling.

## TOOLS AND MATERIALS

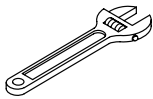

10" Adjustable  
Wrench



Supply  
Shut-Off  
Valve

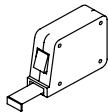

Tape  
Measure

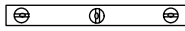

Level

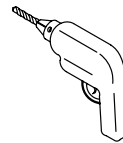

Drill and  
assorted bits

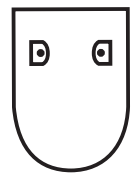

Drilling  
Template

### **Plus:**

- Connector
- Metal File
- 1/2" Nut Driver/Socket
- Hacksaw
- Screwdriver

**Thank you for purchasing your new ANZZI toilet.**

Please read and follow all installation and operation instructions carefully to ensure safe and reliable performance.

**FAILURE TO FOLLOW INSTRUCTIONS COULD RESULT IN PROPERTY DAMAGE OR SERIOUS INJURY.**

Keep this manual for future reference.

# PRODUCT SIZE CHART

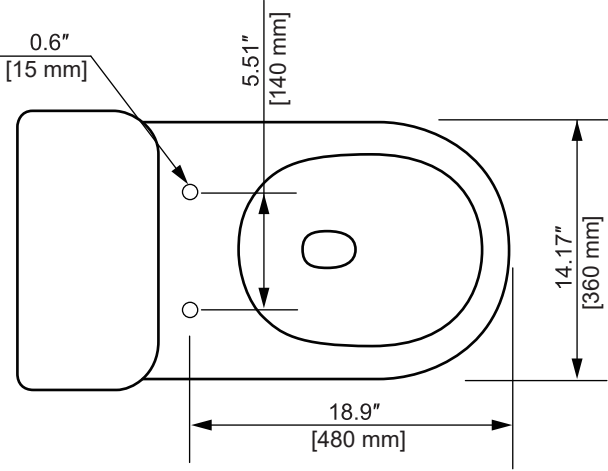
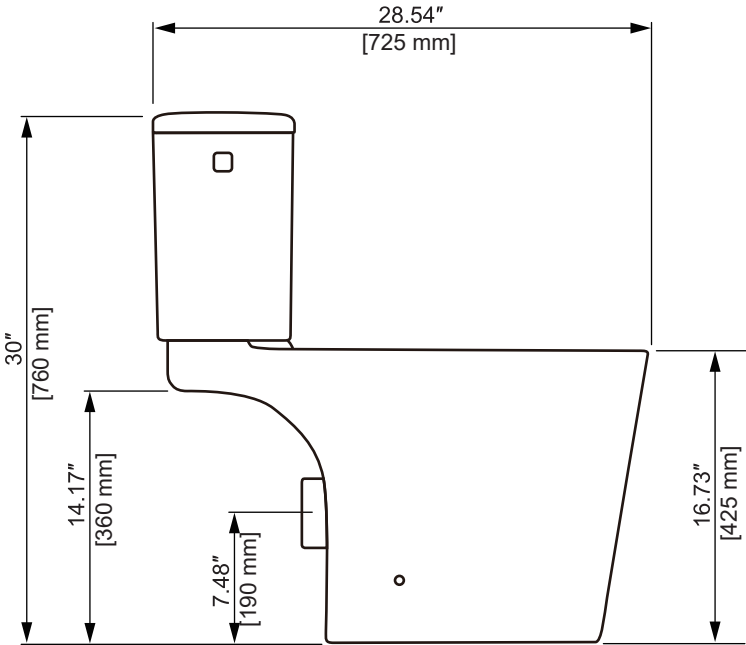

# TOILET INSTALLATION

## ⚠ ATTENTION

**CAUTION: Risk of injury or damage. Handle with care.**

- Vitreous china is delicate and may chip or crack if mishandled.
- Installation must comply with ASME A112.19.2-2013 / CSA B45.13 standards.
- Inspect the toilet thoroughly before installation for any visible damage.
- If the existing setup does not include a shut-off valve beneath the cistern, install one before proceeding.
- Ensure proper backing is installed behind the finished wall to anchor mounting hardware securely.
- A toilet connector is not included and may need to be purchased separately for new installations.

### 1 Removing the Existing Toilet

1. Shut off the water supply and flush the toilet.
2. Use a sponge to remove any remaining water from the cistern.
3. Disconnect the supply shut-off valve (if present), then remove the old toilet and cistern.

**CAUTION: Risk of exposure to sewer gas.**

If installation is delayed, temporarily plug the closet flange with a rag to prevent gas leakage.

### 2 Position the Connector

Place the connector onto the toilet pan.

Align it properly between the outlet and the waste pipe as illustrated.

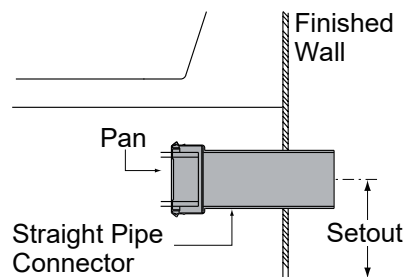

### 3 Mark the Floor Fixing Holes

1. Place the toilet (with the water tank installed) at the desired location, and use a pen to trace the base outline.
2. Move the toilet aside and position the drilling template within the traced outline.
3. Align the edges of the template with the outline and drill holes at the marked positions on the template.

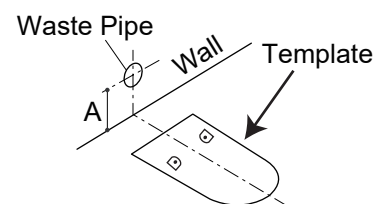

# TOILET INSTALLATION

## 4 Floor Fixing –Using Brackets

1. Drill 10 mm holes at the marked positions on the floor and insert the provided anchors.
2. Place a washer onto each hex screw, insert the screws through the mounting brackets, and fasten them securely to the floor.
3. Align the toilet carefully over the marked area.
4. Insert the sleeves and attach the toilet to the floor brackets using the provided screws.
5. Cover the screw heads with the supplied caps for a clean finish.

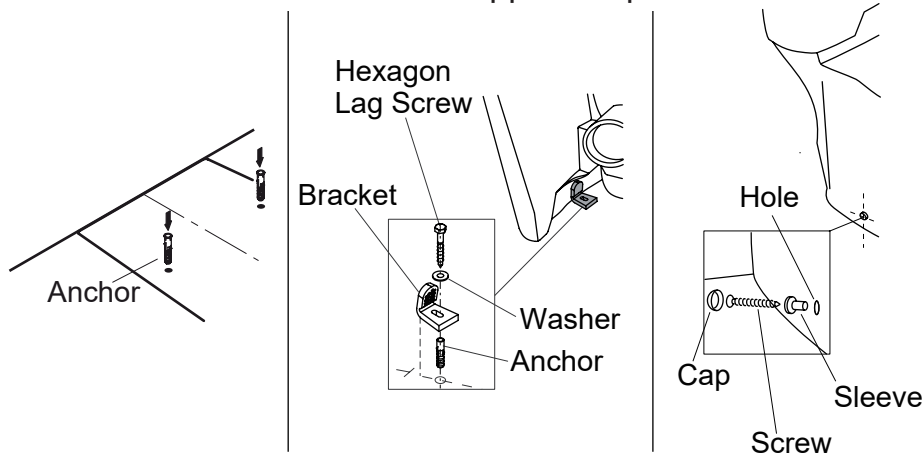

## 5 Macerator Pump Installation(Optional)

**If installing Macerator Pump, please refer to Macerator Pump manual for step by step guide.**

- a. Align the toilet bowl's spigot outlet with the white accordion connector. Mark the mounting holes on the floor through the base of the bowl.
- b. Remove the toilet and drill two holes to match the size of the provided screws. Insert plastic anchors into the holes. If mounting to a wooden floor, drill pilot holes only.
- c. Reposition the bowl in front of the macerator pump. Slide the accordion connector fully onto the spigot outlet and secure it using the supplied clamp.

Ensure that both the accordion connector and clamp are evenly positioned and securely fastened around the outlet.

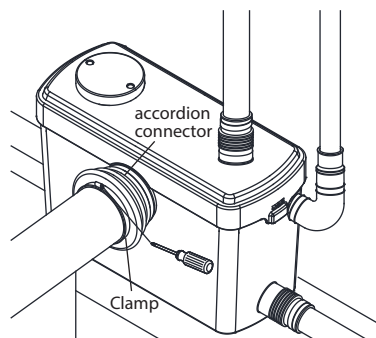

# TOILET INSTALLATION

## 6 Tank Installation

Secure the flush valve nut to ensure it is tightly fastened.

Align the cistern with the pan, ensuring the gasket fits securely over the pan inlet.

Insert the sealing washer and retaining washer onto the screw.

Tighten the screw securely to keep the cistern level and stable.

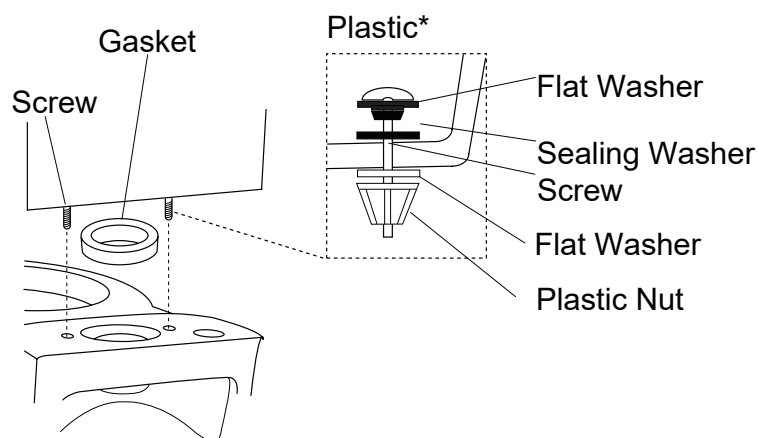

## 7 Hose Installation

a. Connect the hose (not included) to the supply inlet on the toilet and the supply stop valve.

b. Tighten the coupling nut at the tank connection an additional 1/4 turn past hand-tight.

c. Turn on the supply stop valve and allow the tank to fill.

d. Inspect all connections for leaks and tighten if needed.

**Do not overtighten.**

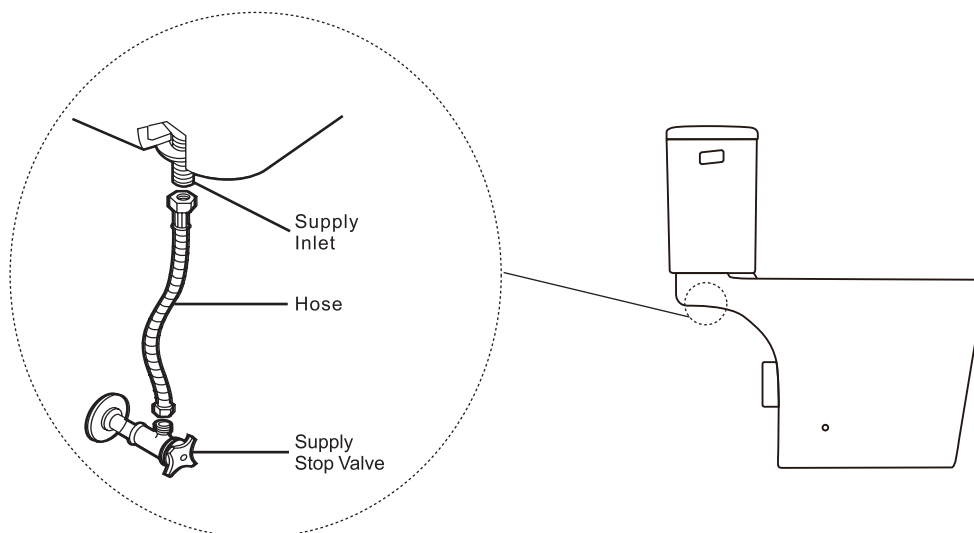

# TOILET INSTALLATION

## 8 Handle Installation

- Remove the nut and washer from the handle assembly. Install the handle assembly on the outside of the tank as shown in the diagram. Connect the chain to the end of the lever arm. Adjust the chain length so it lifts the flapper when the handle is pressed and closes the flapper when released.
  - Adjust the water level by turning the water level adjustment knob to raise or lower the float cup.
- Note: The water level should remain below the top of the overflow tube.
- Carefully place the tank lid back on to complete the installation.

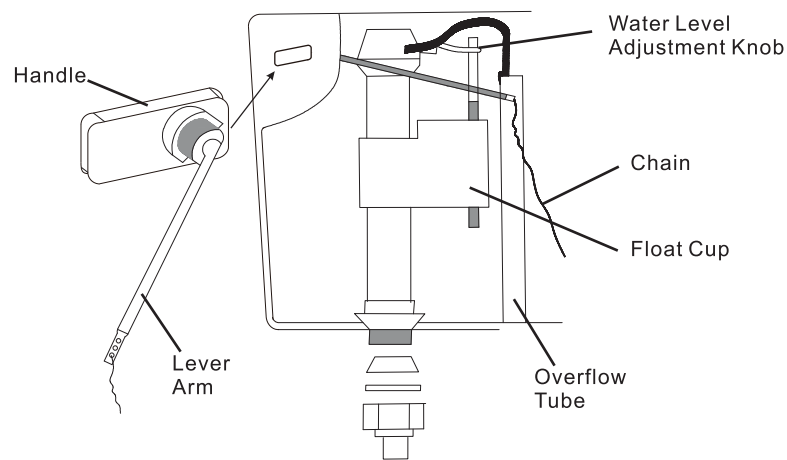

## 9 Seat Installation

Install the toilet seat according to the included seat instructions.

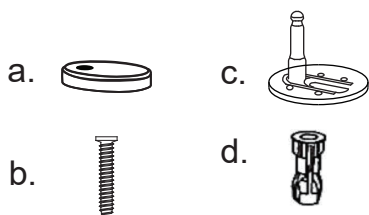

Install the seat:

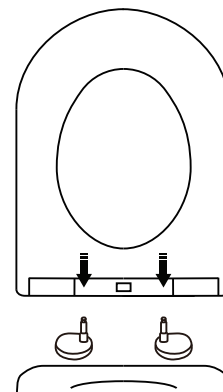
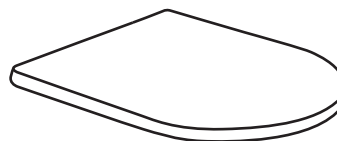
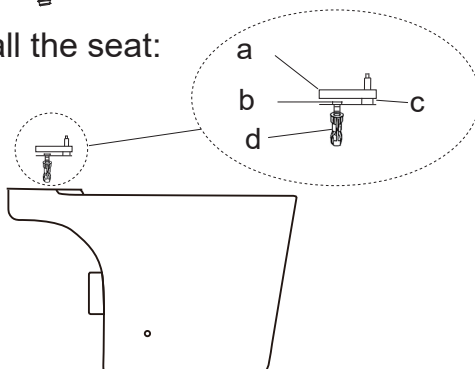

1. Assemble the parts (a, b, c, d) in the order shown in the diagram.

2. Mount the seat vertically onto the toilet and secure it in place.

# TOILET INSTALLATION

## 9 Seat Removal for Maintenance

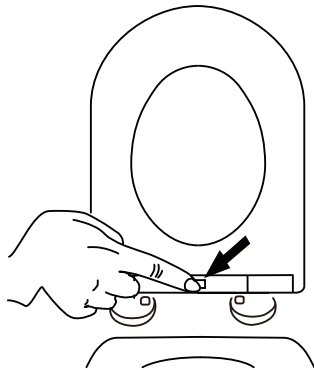

1. Press the release button as shown in the diagram.

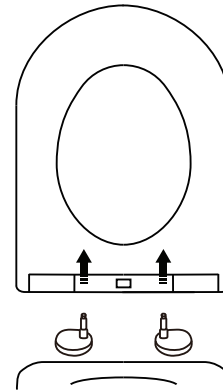

2. Hold the seat vertically and lift it upward to detach it from the toilet.

## CLEANING and MAINTENANCE

To clean your toilet, use mild, soapy water. Rinse thoroughly with clean water and dry with a soft cloth.

Avoid using harsh detergents, disinfectants, or cleaning sprays.

Never use abrasive scouring pads or powders on the toilet seat, as they may damage the finish.

Some bathroom chemicals and cosmetics can also harm the surface.

**Important:** Do not use in-tank cleaners. Products containing chlorine (calcium hypochlorite) can damage internal components and lead to leaks or property damage.

ANZZI is not responsible for any damage caused by the use of such cleaners.

## TROUBLE SHOOTING

Symptoms	Probable Causes	Trouble Shooting
Poor flush.	Supply Stop Valve is not fully open.	Open the Supply Stop Valve
Toilet discharges water continuously	Chain connecting to the Lever Arm is too short	Adjust the Chain length
Excessive noise when tank is filling.	Flush Valve is blocked	Remove debris or blockage from the valve and flush the lines

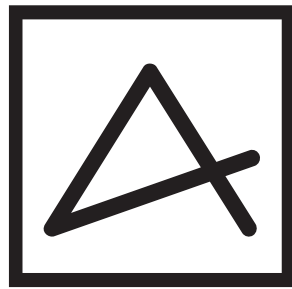

ANZZI®