

Eaton Type CH Convertible Family

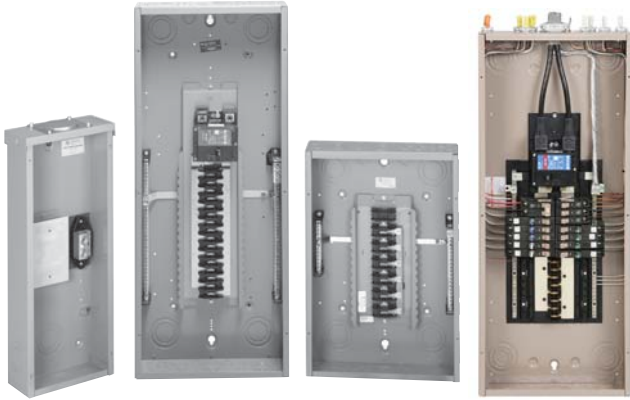

Contents

<i>Description</i>	<i>Page</i>
Overview	
Standards and Certifications	V1-T1-3
Catalog Number Selection	V1-T1-5
Product Selection	V1-T1-7
CH Specialty Products	V1-T1-14
CH Loadcenter Options and Accessories	V1-T1-20
CH Circuit Breakers	V1-T1-35

Overview

Product Description

Loadcenters are enclosures specifically designed to house the branch circuit breakers and wiring required to distribute power to individual circuits. They contain either a main breaker when used at the service entrance point or a main lug when used as a sub-panel to add circuits to existing service. The main breaker protects the main entire panel and can be used as a service disconnect. The branch breakers protect the wires leading to individual electrical loads such as fixtures and outlets.

CH Plug-on Neutral Loadcenter

Quicker, easier and cleaner than the competition. The CH Plug-on Neutral portfolio offers a unique design that offers improved safety, ease of installation and leaves the end result with a clean and professional look and feel.

Features, Benefits and Functions

Loadcenter Construction

Eaton’s Type CH loadcenters feature silver flash plated copper bus in all interiors. Stabs are rated 200 A throughout the CH line. Therefore, the sum of the handle ratings connected to any one stab is limited to 200 A maximum. NEMA 1 boxes are manufactured from cold rolled 16 gauge sheet steel. Raintight boxes are manufactured from galvanized steel. All boxes and trims are finished using an electrostatic powder coat, baked urethane sandalwood paint process.

Neutrals

Eaton Type CH loadcenters feature three types of neutrals:

Insulated/Bondable Split Neutral

Panels are supplied with split insulated neutrals with an insulated cross strap. For service entrance applications, the neutral must be bonded by using the bonding strap supplied with the panel. For non-service entrance (sub-panel) applications, the panel may be installed with the bonding strap not connected to the neutral. Separate ground bars must be used on non-service entrance panels.

Inboard Plug-on Neutral

Code changes and higher safety standards are leading to more arc fault circuit interrupter (AFCI) installations. With the electrical contractor in mind, Eaton has revolutionized the way Combination AFCIs are installed with the Plug-on Neutral line of loadcenters and breakers.

This unique product solution enables the contractor to connect the breaker directly to the neutral bar, eliminating the need for wiring a pigtail.

Insulated/Bondable Single Neutral

Panels are supplied with a single insulated neutral. For service entrance applications, all that is required to bond the neutral is to loosen the bonding screw and the neutral screw directly beside it, insert the bonding strap into the neutral bar, and re-tighten both connections. The single neutral can be moved by the contractor to the other side of the panel, if desired. When used as a service entrance panel, unused neutral connections may be used for the termination of equipment grounds. For non-service entrance (sub-panel) applications, the panel may

be installed with the bonding strap not connected to the neutral. Separate ground bars must be used on non-service entrance panels.

Grounds

In service entrance applications where the neutral is bonded, unused neutral holes may be used for terminating ground conductors. In sub-feed panels, the neutral must be isolated (non-bonded), and ground wires must be terminated on a separate ground bar. All CH Main Lug Only Plug-on Neutral loadcenters come with a factory-installed ground bar.

The insulated/bondable single/split neutral panels have sufficient terminations for both ground and neutral conductors. The insulated/bondable single split neutral panels are supplied with a separate factory-installed ground bar if the catalog number contains a “G.” If not, a separate ground bar should be installed. Insulated/Bondable Single Neutral panels are supplied without a ground bar (unless otherwise noted), and ground bar kits, if needed, must be purchased separately.

Neutral and Ground Terminals

The standard terminals on grounds and neutrals are rated to accept (3)—#14—#10 Cu/Al or (1)—#14—4 wires. For larger cables, add-on neutral lugs may be ordered from the Accessories.

Note: NEC® allows only one current carrying conductor per hole on neutrals unless otherwise noted.

Bottom-Fed Loadcenters

When the power cable is brought into the loadcenter from below the panel; then the main lug panels, and single-phase, 225 A and below, loadcenters can be rotated 180 degrees to allow straight-in wiring of power cables to the main terminals. Because the CSR main circuit breaker handle operates horizontally, the orientation of the main circuit breaker handle is consistent with the requirements of NEC Article 240.81.

Gutter Splicing

Loadcenters are not UL listed as wiring troughs. Therefore, gutter splicing of riser cables to tap off to the main device is not permitted. Refer to NEC Article 373.8.

Fire Rating

Due to the numerous openings in both loadcenter boxes and trims, they should not be mounted in firewalls. There is no approval method for sealing the enclosures for this application.

Date Code

The date of manufacture of each loadcenter is printed on the outside of the carton as well as inside the loadcenter. On the carton, the date code is printed on the end carton label. In the loadcenter, the date code is located on the small white label located on the right side wall (with the main device on top).

The date code is in the following format: F # # # &. The “F” is the numeric code for the Lincoln, IL plant, and the three numbers are the year and week of manufacture, e.g., 023. The “&” sign at the end signifies the decade of the 2000s. The “!” at the end signifies the decade of the 2010s. Therefore, the date code F023& would indicate that the product was manufactured in the 23rd week of 2000. The 1980s are represented by a “+” sign and the 1990s are represented by a “=” at the end of the code.

Plug-on Type CH Breakers

Quick-make, quick-break switch mechanism combined with inverse time element tripping operation and trip-free handle design. Type CH circuit breakers trip to the OFF position eliminating nuisance callbacks. The thermal-magnetic trip curve avoids nuisance tripping on mild overloads while reacting almost instantaneously to severe short-circuit conditions. CHF breakers include a ‘trip flag’ to differentiate between a tripped breaker and one that has been turned off. Multipole breakers have internal common trip connection to operate all poles simultaneously. Handles are marked with ON-OFF indication and ampere rating of the breaker. Type CH breakers meet UL Standard 489, NEMA standards, and Federal Spec Classification W-C 375 b/Gen. They are UL listed under File Number E11713, E8741, E3624 and E51287; and CSA® certified file number LR87196, except Type CHT breakers.

Type CH Circuit Breaker Ratings

Single- and double-pole CH breakers rated 15 and 20 A have low instantaneous magnetic trip levels. The 15 and 20 A breakers with “HM” suffix have high magnetic trip settings recommended for circuits with inherently high inrush currents. All Type CH breakers are marked for heating, air conditioning and refrigeration (HACR) equipment application. Single-pole 15–20 A breakers are also suitable for switching duty (SWD). Shunt trip coils operate on 120 Vac and require one additional pole space per breaker.

Standards and Certifications**UL® Listings**

All Eaton Type CH loadcenters are listed under the UL 67 certification in file E8741.



1.1

Loadcenters and Circuit Breakers

Type CH Loadcenters and Circuit Breakers

1

Type CH Loadcenter

Optimized Knockouts

- Provide additional access and allow for easier removal improving installation times

Top or Bottom Feed

- Straight-in wiring saves labor and material
- One panel for either top or bottom applications

Smooth Case Edges

- Provide a more professional look and feel

2/0 Lug

- Easily removable and can be installed in any location on the neutral bar

Commercial Grade Main Breaker

- 25 kAIC series rated main breaker in 150 A–225 A loadcenters. 35, 42 and 100 kAIC series ratings are available
- Optional convertible design—reduces inventory requirements

Full Length Neutral Bars

- Offer flexibility of placing electronic breakers at any space within the panel
- Offer easy installation of neutral connection time and labor savings

Inboard Neutral

- Increases gutter space to allow for the installation of conductors

One Piece Silver-Flashed Copper Bus

- Provides superior conductivity, corrosion resistance and durability

Drywall Offsets

- (located on both sides of enclosure)
- Allow for faster installation using predetermined self-leveling tabs

Steel Backpan

- Provides solid and reliable breaker mounting—single piece design for stability and durability

“Tangential” Center Knockout

- Easier installation for conduit applications

Unique Sandalwood Finish

- Aesthetically appealing, scratch-resistant powder coating

Full Length Neutral Bars

- Offer flexibility of placing electronic breakers at any space within the panel
- Allow for easy installation of neutral wire connection

Plug-On Neutral

- Eliminates the pigtail connection providing time and labor savings
- Provides a professional installation

Type CHF AFCI/GFCI/Thermal-Magnetic Breakers

- Advanced electronics effectively reduce nuisance tripping
- CHF AFCI breakers have a standard diagnostic LED indicating 1 of 7 trip codes
- Mechanical flag for trip indication (on thermal-magnetic AFCI and GFCI)
- All CH breakers provide industry exclusive 2-position handle with simple 1 step reset

Cover Features not Shown:

- Improved Cover Twist-Outs
- Easier to remove twistouts

Embossed Cover Circuit Numbers

- Durable circuit numbering with added marking for twin breakers

Cover Keyhole Hanging Feature

- Provide easier cover installation by allowing quick hanging of cover regardless of orientation of the panel

Rigid Center Cover Spine

- Provides strengthened center spine when the twistouts are removed

Single Keyhole Mounting

- One keyhole at the top and bottom provides easier mounting and leveling

Warranty

The minimum warranty for residential loadcenters, breakers and surge protection devices shall be as follows:

- Lifetime loadcenter warranty

- Lifetime warranty on CH circuit breakers
- Lifetime warranty on CHSPT2ULTRA including \$75,000 connected equipment warranty

- 1-year warranty on plug-in surge protective device (CHSA)

Catalog Number Selection

CH Plug-on Neutral Loadcenters

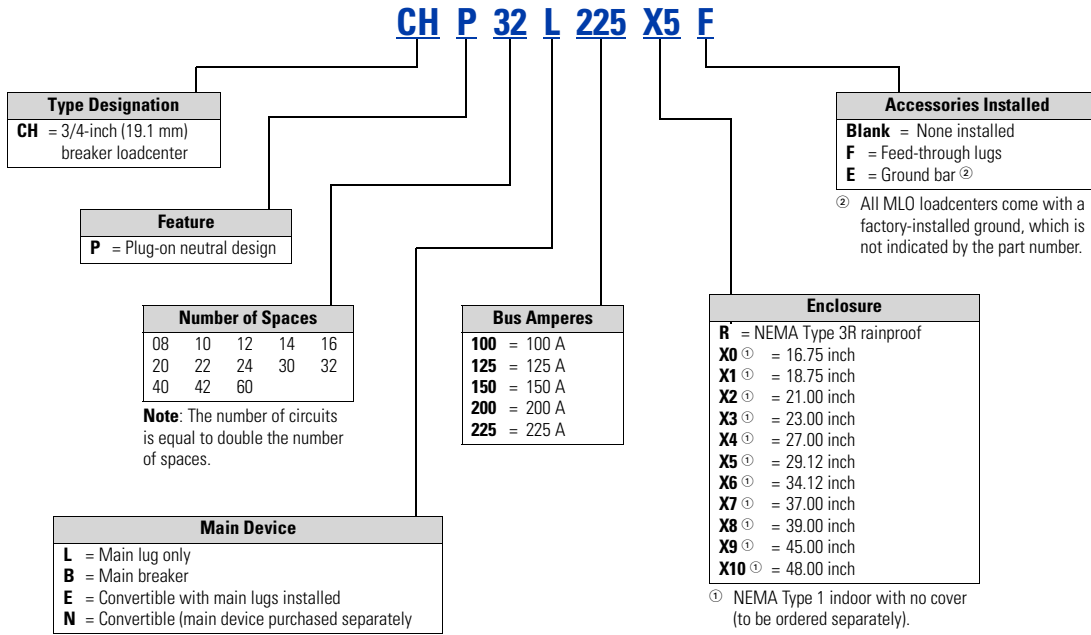

CH Plug-on Neutral Covers (Ordered Separately)

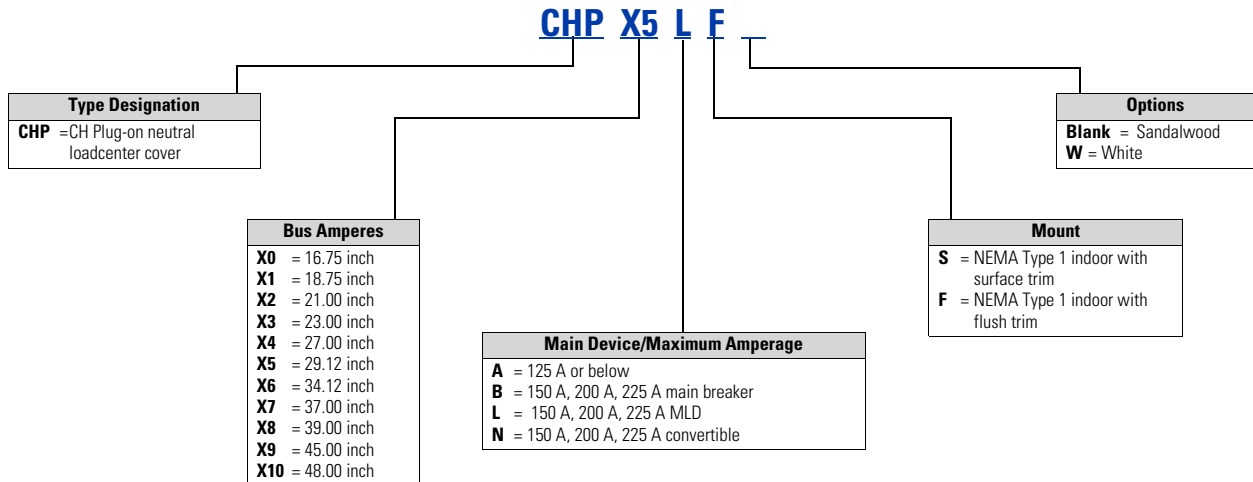

Single-Phase—Main Lug Loadcenters

CHP12L125X0



Single-Phase Three-Wire—120/240 Vac—Insulated/Bondable Split Neutral—Factory-Installed Ground Bar

Main Ampere Rating	Maximum Number 3/4-Inch (19.1 mm) Spaces	Maximum Number 3/4-Inch (19.1 mm) Poles	Enclosure Type	Box Size	Wire Size Range Cu/Al 60 °C or 75 °C for Main Breaker	Loadcenter Catalog Number	Loadcenter Cover Catalog Number Flush	Surface
125	12	24	Indoor	X0	#6–2/0	CHP12L125X0 ①	CHPX0AF	CHPX0AS
	12	24	Outdoor	X0R	#6–2/0	CHP12L125R ①②	—	—
	16	32	Indoor	X1	#6–2/0	CHP16L125X1 ①	CHPX1AF	CHPX1AS
	16	32	Outdoor	X0R	#6–2/0	CHP16L125R ①②	—	—
	20	40	Indoor	X2	#6–2/0	CHP20L125X2 ①	CHPX2AF	CHPX2AS
	20	40	Outdoor	X2R	#6–2/0	CHP20L125R ①②	—	—
	24	48	Indoor	X2	#6–2/0	CHP24L125X2 ①	CHPX2AF	CHPX2AS
	24	48	Outdoor	X2R	#6–2/0	CHP24L125R ①②	—	—
150	24	48	Indoor	X5	#4–300 kcmil	CHP24L150X5 ①③	CHPX5LF	CHPX5LS
	32	64	Indoor	X5	#4–300 kcmil	CHP32L150X5 ①③	CHPX5LF	CHPX5LS
200	12	24	Outdoor	X5R	#4–300 kcmil	CHP12L200R ②④	—	—
	16	32	Indoor	X5	#4–300 kcmil	CHP16L200X5 ①③	CHPX5LF	CHPX5LS
	16	32	Outdoor	X5R	#4–300 kcmil	CHP16L200R ②④	—	—
225	24	48	Indoor	X5	#4–300 kcmil	CHP24L225X5 ①③	CHPX5LF	CHPX5LS
	24	48	Outdoor	X5R	#4–300 kcmil	CHP24L225R ②④	—	—
	32	64	Indoor	X5	#4–300 kcmil	CHP32L225X5 ①③	CHPX5LF	CHPX5LS
	32	64	Outdoor	X5R	#4–300 kcmil	CHP32L225R ②④	—	—
	42	84	Indoor	X6	#4–300 kcmil	CHP42L225X6 ①③	CHPX6LF	CHPX6LS
	42	84	Outdoor	X6R	#4–300 kcmil	CHP42L225R ②④	—	—
400	42	84	Indoor	P	(2) 1/0–300 kcmil (1) 750 kcmil	CHP42PL400 ⑤	CH7PF ⑥	CH7PS

Notes

- ① Suitable for use as service equipment when not more than six disconnecting means are provided.
- ② Rainproof panels are furnished with hub closure plates. For rainproof hubs, refer to **Page V1-T1-25**.
- ③ Suitable for use as service equipment when a circuit breaker is used as a main breaker. The main breaker is backfed and requires hold-down bracket kit catalog number **CHPHD**.
- ④ Suitable for use as service equipment when a circuit breaker is used as a main breaker. The main breaker is backfed and requires hold-down bracket kit catalog number **CH125RB**.
- ⑤ Suitable for use as service equipment when a circuit breaker is used as a main breaker. The main breaker is backfed and must be a Type **CHB**.
The breaker cannot be a Type CH.
- ⑥ This cover is for flush application only (not combination).

Box sizes **Pages V1-T1-31 and V1-T1-33**.