

High Amperage Heavy Duty Circuit Breaker

253

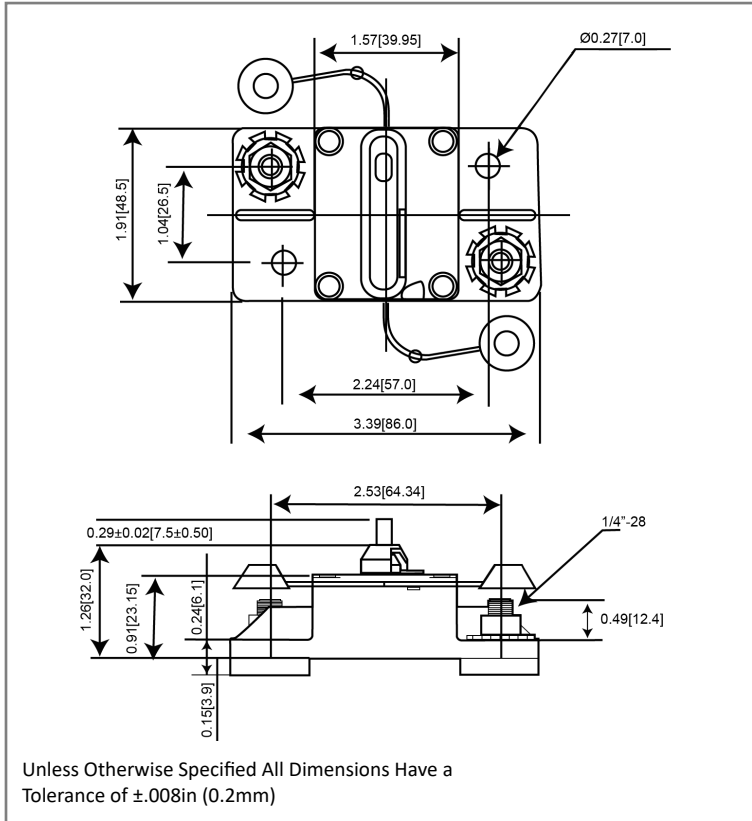

Mechanical Dimensions: Inches [mm]



Retail Pack: Inches [mm]

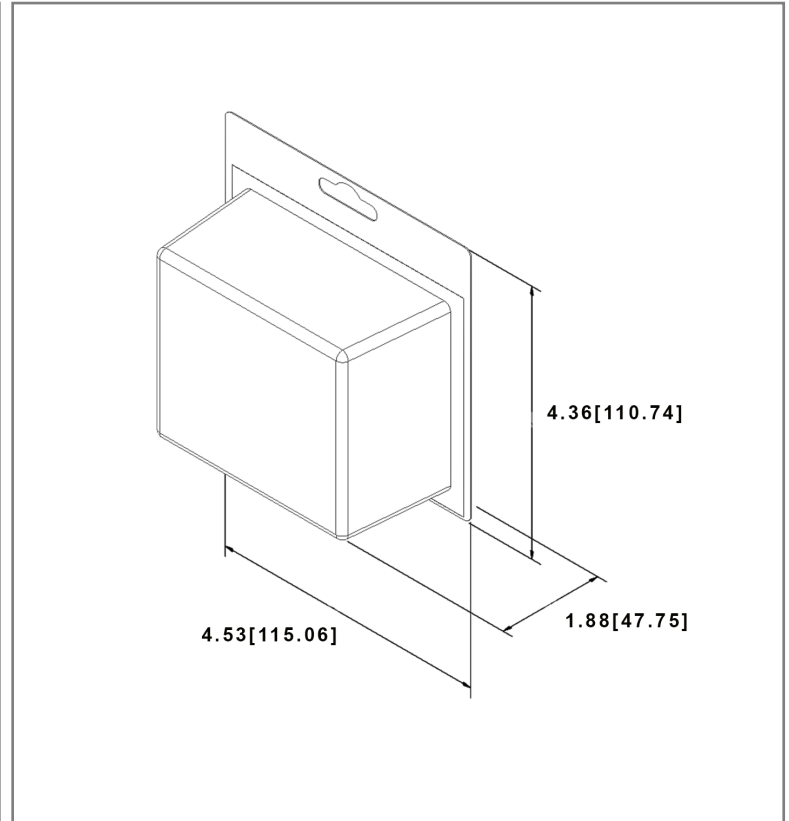

Time vs. Percent of Rated Current

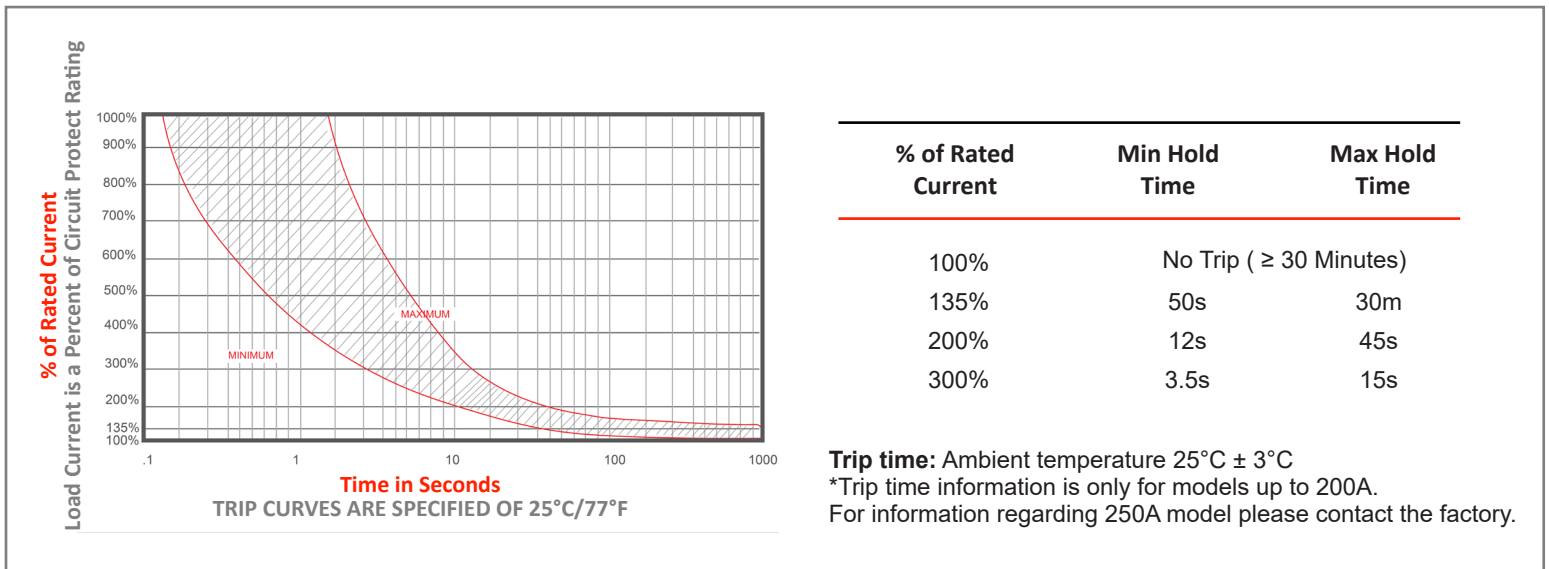

Electrical Specifications

Voltage Rating	42VDC; 48VDC
Reset Type	Type III - Manual Reset
Interrupting Rating	3000A @ 30VDC (ABYC E-11); 1500A @ 48VDC; 3000A @ 44VDC
Operation Temperature	-25 °F ~ 180 °F -32 °C ~ 82 °C
Testing	SAE J553, ABYC-E11, UL1077

Material Specifications

Heavy Duty High Amp - Waterproof Circuit Breaker	
Body Material	Thermoset Plastic (UL94V-0)
Terminals Material	Nickel Plated
Terminals Configuration	1/4"-28 Stud
Mounting Type	Surface Mount
Studs Torque	10.3 N.m max.
Mounting Torque	~13.6 N-m MAX
Ignition Protected	SAE J1171
Ingress Protection	IP67

Part Numbers Information

Amperage	Bulk Part #	Retail Pack # Blister Card	Pack Size
25A	253025	253025-BP	1
30A	253030	253030-BP	1
40A	253040	253040-BP	1
50A	253050	253050-BP	1
60A	253060	253060-BP	1
70A	253070	253070-BP	1
80A	253080	253080-BP	1
90A	253090	253090-BP	1
100A	253100	253100-BP	1
120A	253120	253120-BP	1
135A	253135	253135-BP	1
140A	253140	253140-BP	1
150A	253150	253150-BP	1
175A	253175	253175-BP	1
200A	253200	253200-BP	1
250A	253250	253250-BP	1

Rev	Date of issue	Revision Notes	Designed	Approved
I	10-14-2025	Updated Voltage Rating; Updated Interrupting Rating	RC	OF