

# 3-SHELF STOCKPICKER TRUCK - SPS3-2840

APPROX WEIGHT: 161.33 lbs.  
 DOES NOT INCLUDE WEIGHT OF POWER OR PACKAGING!!!

\*\*\* ANY ADDITIONS, DELETIONS, OR OMISSIONS MUST BE CORRECTED ON THIS DRAWING AS THIS DRAWING WILL BE CONSIDERED ALL INCLUSIVE \*\*\*

ALL GRAPHICS PROVIDED ARE FOR REFERENCE ONLY. IF CERTAIN DIMENSIONS ARE CRITICAL PLEASE VERIFY THOSE DIMENSIONS WITH YOUR SALESPERSON

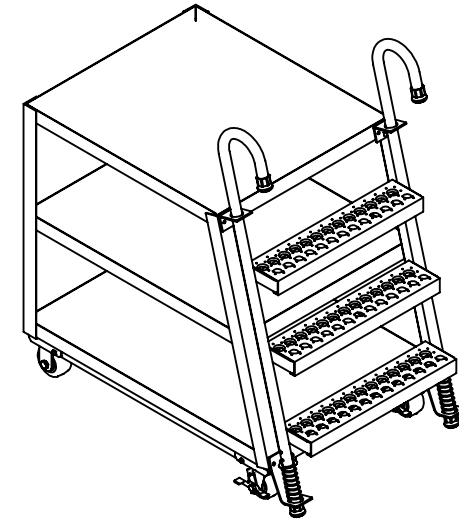
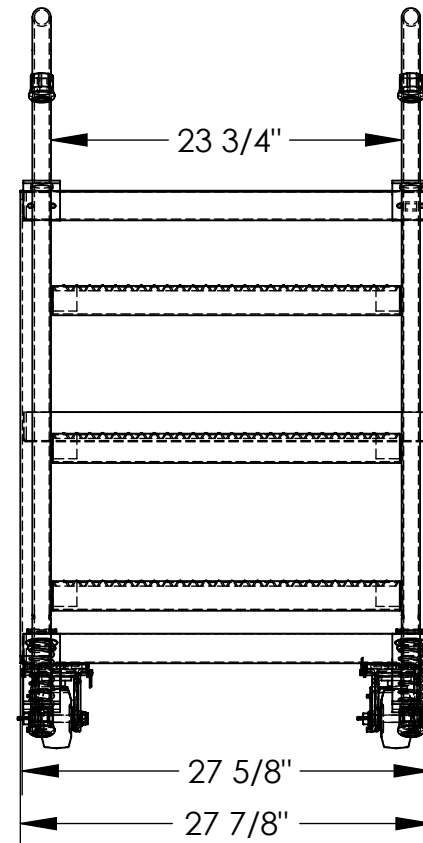
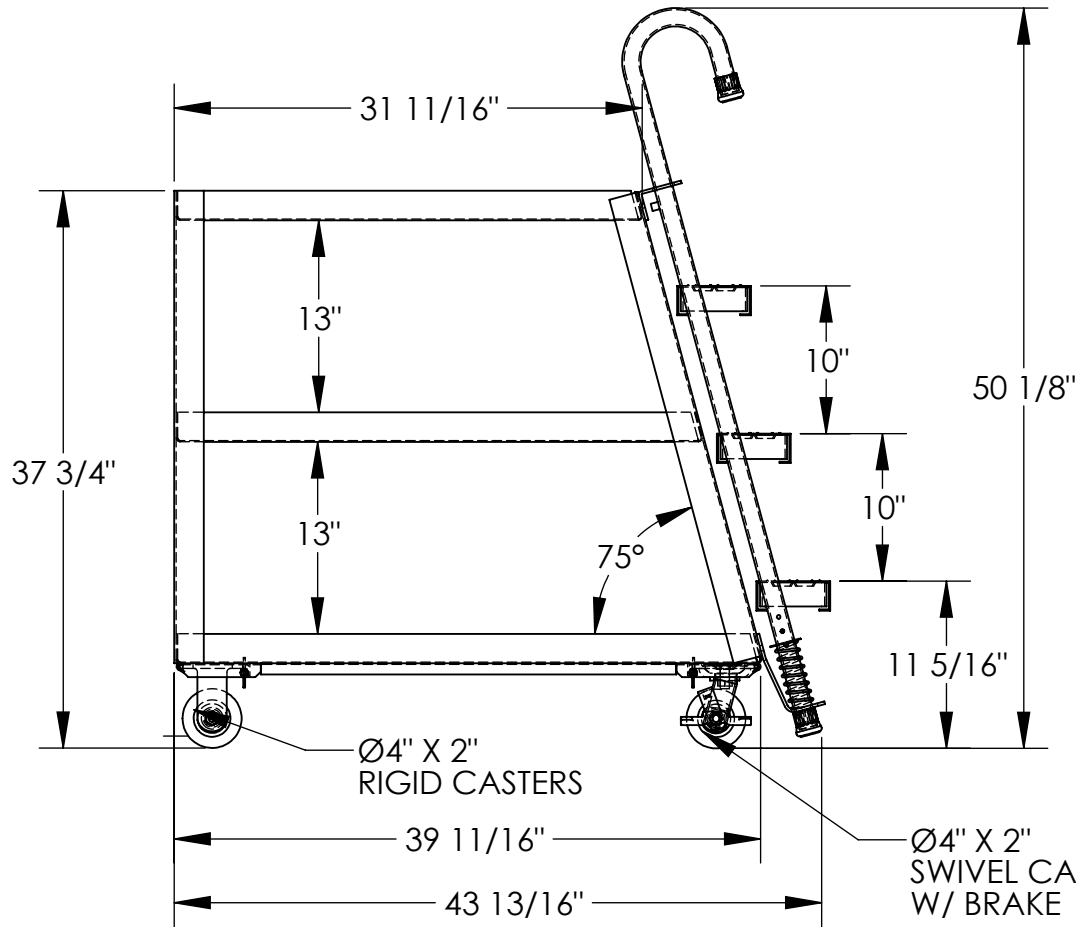

3D VIEW SHOWN FOR REFERENCE ONLY

DIMENSION TOLERANCE ± 1/4"

**APPROVAL**

I, THE UNDERSIGNED, AGREE THAT THE PRODUCT AS REPRESENTED SATISFIES DESIGN AND DIMENSION REQUIREMENTS. I ALSO ACKNOWLEDGE MY DUTY TO CONFIRM PRODUCT AND INSTALLATION COMPLIANCE WITH ALL APPLICABLE FEDERAL, STATE AND LOCAL REGULATIONS AND STANDARDS.  
**UNITS REQUIRING APPROVAL DRAWINGS OR MODIFIED ARE NON-RETURNABLE**

[ ] As drawn [ ] As marked

Signed: \_\_\_\_\_ Date: \_\_\_\_\_

Printed Name: \_\_\_\_\_

LEAD TIME WILL START UPON RECEIPT OF SIGNED APPROVAL DRAWING

DISTRIBUTOR'S NAME:		P.O.#
VESTIL MANUFACTURING		X
DRAWN BY: NHD		W.O.#
DATE: 08/25/2017		X
REFERENCE: X	SCALE: 1:13	SALES: X
QUOTED LEAD TIME: X	QUOTE # X	FILE NAME:
		32-007-045

## STANDARD FEATURES

- MODEL NUMBER IS SPS3-2840
- CAPACITY IS 1000 LBS. (550 LBS. PER SHELF)
- OVERALL WIDTH IS 27 7/8"
- OVERALL LENGTH IS 43 13/16"
- OVERALL HEIGHT IS 50 1/8"
- BOTTOM SHELF SIZE IS 27 5/8" X 39 11/16"
- TOP SHELF SIZE IS 23 3/4" X 31 11/16"
- TOP SHELF HEIGHT IS 37 3/4"
- SHELF CLEARANCE IS 13"
- CASTERS ARE 4" X 2" MOLD-ON-RUBBER
- (2) RIGID, (2) SWIVEL
- STEEL FRAME CONSTRUCTION
- DURABLE BAKED IN POWDER COATED BLUE FINISH
- LADDER CAPACITY IS 350 LBS

## SPECIAL FEATURES

NONE