

Mechanical Dimensions: Inches [mm]

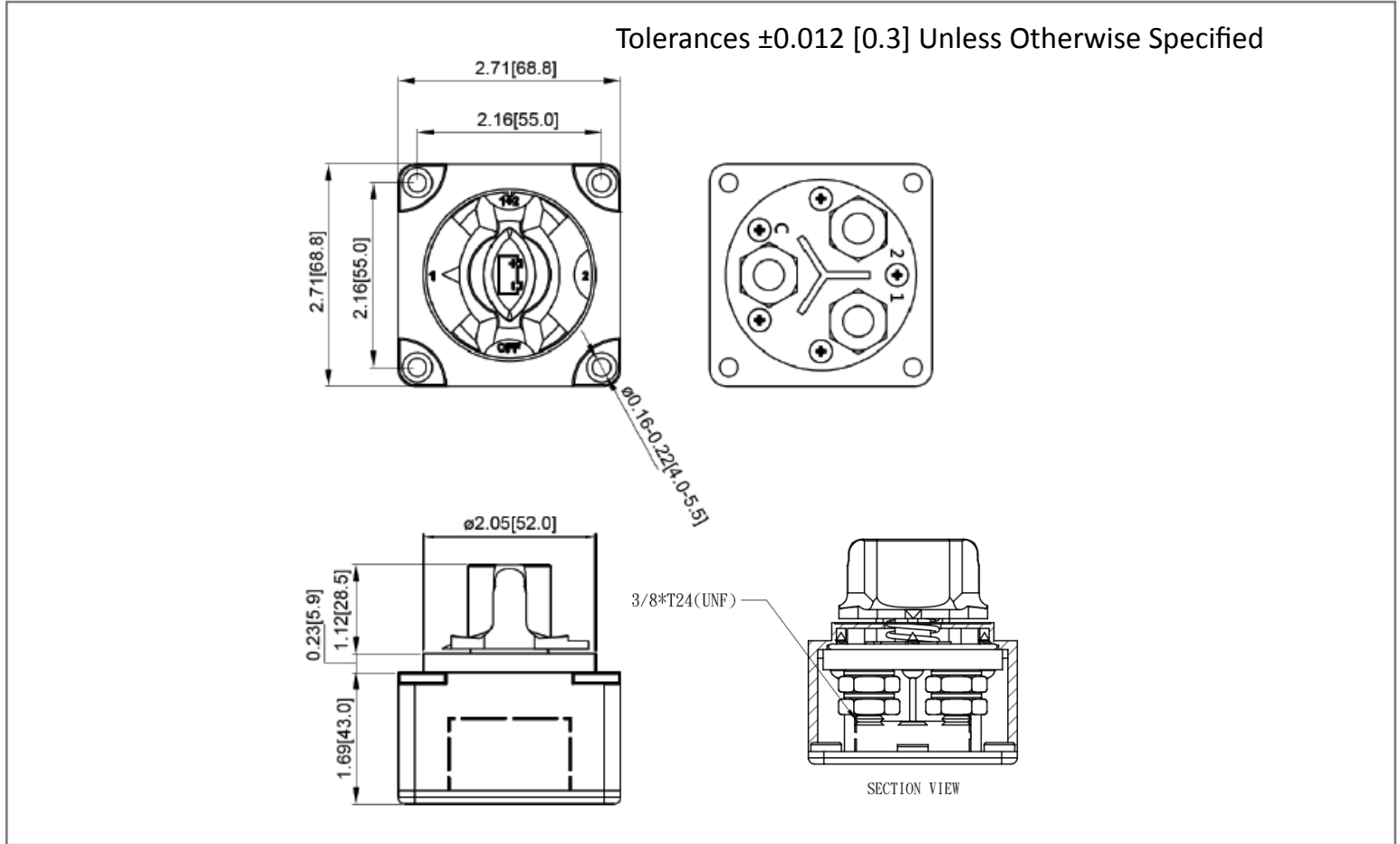

Circuit Diagram

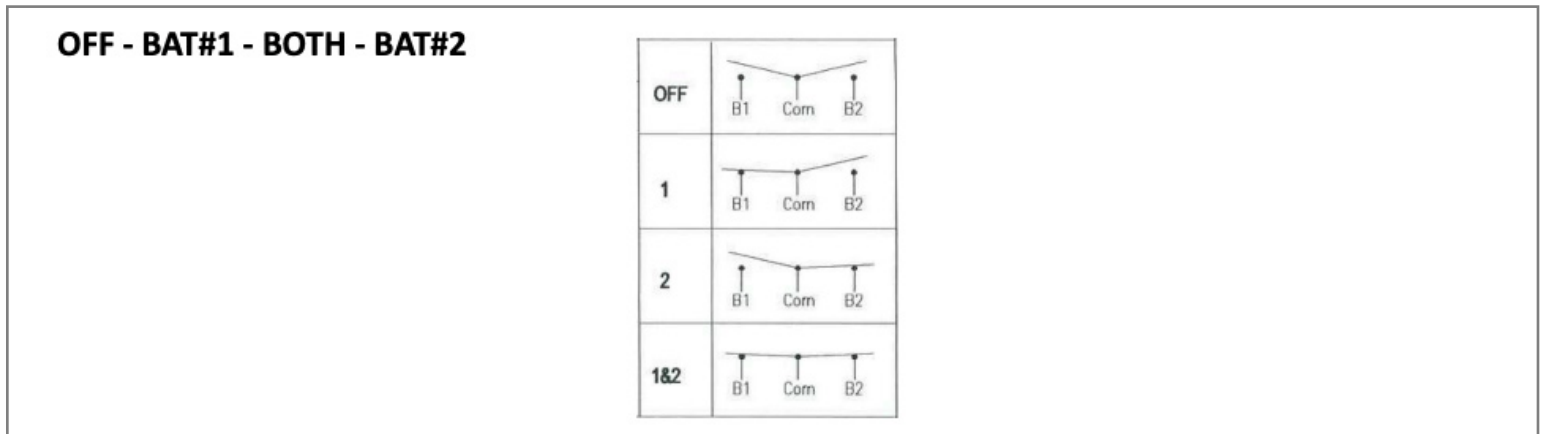

Electrical Specifications

Continuous Rating	300A 12-48V DC
Intermittent Rating	700A
Cranking Rating	1000A for 5 secs
Insulation Resistance	DC 500V 1M ohm Min.
Operation Temperature	-40°C ~ 85°C

Material Specifications

IP66	
Housing	Nylon with 30% Fiberglass
Bottom	PBT
Terminals / Contacts	Copper, Silver plated
Actuator	Silver plated
Ignition Protected	ISO 8846

Rev	Date of issue	Revision Notes	Designed	Approved
C	04-12-2024	Updated Material Specifications	RC	OF