

QSFP28-100G-LR4-CARJ-AO

Cisco®, Arista® and Juniper® Compatible TAA Compliant 100GBase-LR4 QSFP28 Transceiver (SMF, 1295nm to 1309nm, 10km, LC, DOM)

Features

- Hot pluggable QSFP28 MSA form factor
- Compliant to IEEE 802.3ba 100GBase-LR4
- Up to 10km reach for G.652 SMF
- Single +3.3V power supply
- Operating case temperature: 0°C to 70°C
- Transmitter: cooled 4x25Gb/s LAN WDM EML TOSA (1295.56, 1300.05, 1304.58, 1309.14nm)
- Receiver: 4x25Gb/s PIN ROSA
- 4x28G Electrical Serial Interface (CEI-28G-VSR)
- Maximum power consumption 4.0W
- Duplex LC receptacle
- RoHS-6 compliant



Applications

- 100GBase-LR4 Ethernet Links
- InfiniBand QDR and DDR interconnects
- Client-side 100G Telecom connections

Product Description

This Cisco®, Arista® and Juniper® compatible QSFP28 transceiver provides 100GBase-LR4 throughput up to 10km over single-mode fiber (SMF) using a wavelength of 1295nm to 1309nm via an LC connector. It is guaranteed to be 100% compatible with the equivalent Cisco®, Arista® and Juniper® transceiver. This easy to install, hot swappable transceiver has been programmed, uniquely serialized and data-traffic and application tested to ensure that it will initialize and perform identically. Digital optical monitoring (DOM) support is also present to allow access to real-time operating parameters. This transceiver is Trade Agreements Act (TAA) compliant. We stand behind the quality of our products and proudly offer a limited lifetime warranty.

AddOn's QSFP28 transceivers are RoHS compliant and lead-free.

TAA refers to the Trade Agreements Act (19 U.S.C. & 2501-2581), which is intended to foster fair and open international trade. TAA requires that the U.S. Government may acquire only "U.S. – made or designated country end products."



Regulatory Compliance

- ESD to the Electrical PINs: compatible with MIL-STD-883E Method 3015.4
- ESD to the LC Receptacle: compatible with IEC 61000-4-3
- EMI/EMC compatible with FCC Part 15 Subpart B Rules, EN55022:2010
- Laser Eye Safety compatible with FDA 21CFR, EN60950-1& EN (IEC) 60825-1,2
- RoHS compliant with EU RoHS 2.0 directive 2015/863/EU

Absolute Maximum Ratings

Parameter	Symbol	Min.	Typ.	Max.	Unit
Supply Voltage	Vcc	-0.5		3.6	V
Damage Threshold, each Lane	THd	5.5			dBm
Storage Temperature	Tst	-40		85	°C
Case Operating Temperature	Top	0		70	°C
Humidity (non-condensing)	Rh	5		85	%

Recommended Operating Conditions

Parameter	Symbol	Min.	Typ.	Max.	Unit
Supply Voltage	Vcc	3.13	3.3	3.47	V
Operating Case Temperature	Tca	0		70	°C
Data Rate Per Lane	fd		25.78125		Gbps
Control Input Voltage High		2		Vcc	V
Control Input Voltage Low	Pm	0		0.5	V
Link Distance with G.652	D			10	km

Electrical Characteristics

Parameter	Symbol	Min.	Typ.	Max.	Unit	Notes
Power Consumption				4.0	W	
Supply Current	I _{cc}			1.21	A	
Transceiver Power-on Initialization Time				2000	ms	1
Transmitter						
Single-ended Input Voltage Tolerance		-0.3		4.0	V	2
AC Common Mode Input Voltage Tolerance		15			mV	RMS
Differential Input Voltage Swing Threshold		50			mV _{pp}	LOSA Threshold
Differential Input Voltage Swing	V _{in,pp}	190		700	mV _{pp}	
Differential Input Impedance	Z _{in}	90	100	110	Ohm	
Receiver						
Single-ended Output Voltage		-0.3		4.0	V	
AC Common Mode Output Voltage				7.5	mV	RMS
Differential Output Voltage Swing	V _{out,pp}	300		850	mV _{pp}	
Differential Output Impedance	Z _{out}	90	100	110	ohm	

Notes:

1. Power-on Initialization Time is the time from when the power supply voltages reach and remain above the minimum recommended operating supply voltages to the time when the module is fully functional.
2. The single ended input voltage tolerance is the allowable range of the instantaneous input signals.

Optical Characteristics

Parameter	Symbol	Min.	Typ.	Max.	Unit	Notes	
Lane Wavelength	L0	1294.53	1295.56	1296.59	nm		
	L1	1299.02	1300.05	1301.09			
	L2	1303.54	1304.58	1305.63			
	L3	1308.09	1309.14	1310.19			
Transmitter							
RMSR	SMSR	30			dB		
Total Average Launch Power	P_T			10.5	dBm		
Average Launch Power, each Lane	P_{AVG}	-4.3		4.5	dBm		
OMA, each Lane	P_{OMA}	-1.3		4.5	dBm		
Difference in Launch Power between any Two Lanes (OMA)	$P_{Tx,diff}$			5	dB		
Launch Power in OMA minus Transmitter and Dispersion Penalty (TDP), each Lane		-2.3			dBm		
TDP, each Lane	TDP			2.2	dB		
Extinction Ratio	ER	4			dB		
RIN _{20OMA}	RIN			-130	dB/Hz		
Optical Return Loss Tolerance	TOL			20	dB		
Transmitter Reflectance	R_T			-12	dB		
Eye Mask Coordinates: X1, X2, X3, Y1, Y2, Y3	Specification Values 0.25, 0.4, 0.45, 0.25, 0.28, 0.4						2
Average Launch Power OFF Transmitter, each Lane	P_{off}			-30	dBm		
Receiver							
Damage Threshold, each Lane	TH_d	5.5			dBm	3	
Total Average Receive Power				10.5	dBm		
Average Receive Power, each Lane		10.6		4.5	dBm		
Receiver Power (OMA), each Lane				4.5	dBm		
Receiver Sensitivity (OMA), each Lane	SEN			-8.6	dBm		
Stressed Receiver Sensitivity (OMA), each Lane				-6.8	dBm	4	
Difference in Receive Power between any Two Lanes (OMA)	$P_{rx,diff}$			5.5	dB		
LOS Assert	LOSA		-18		dBm		
LOS De-assert	LOSD		-15		dBm		
LOS Hysteresis	LOSH	0.5			dB		
Receiver Electrical 3 dB upper Cutoff Frequency, each Lane	F_c			31	GHz		

Notes:

1. Even if the TDP < 1 dB, the OMA min must exceed the minimum value specified here.
2. See Figure 1 below.
3. The receiver shall be able to tolerate, without damage, continuous exposure to a modulated optical input signal having this power level on one lane. The receiver does not have to operate correctly at this input power.
4. Measured with conformance test signal at receiver input for BER = 1×10^{-12}
5. Vertical eye closure penalty and stressed eye jitter are test conditions for measuring stressed receiver sensitivity. They are not characteristics of the receiver.

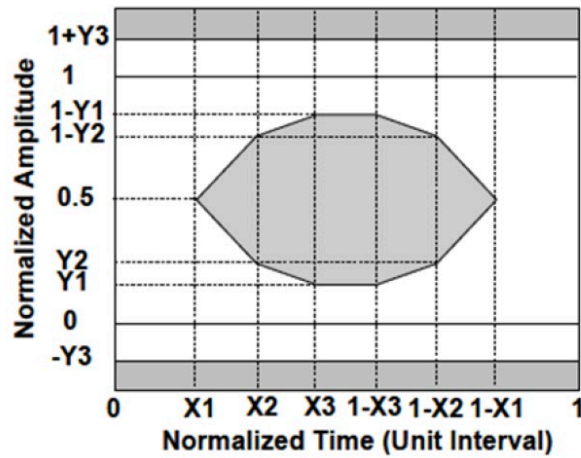

Figure 1. Eye Mask Definition

Pin Descriptions

Pin	Logic	Symbol	Name/Descriptions	Ref.
1		GND	Module Ground	1
2	CML-I	Tx2-	Transmitter inverted data input	
3	CML-I	Tx2+	Transmitter non-inverted data input	
4		GND	Module Ground	1
5	CML-I	Tx4-	Transmitter inverted data input	
6	CML-I	Tx4+	Transmitter non-inverted data input	
7		GND	Module Ground	1
8	LVTTL-I	MODSEIL	Module Select	2
9	LVTTL-I	ResetL	Module Reset	2
10		VCCRx	+3.3v Receiver Power Supply	
11	LVC MOS-I	SCL	2-wire Serial interface clock	2
12	LVC MOS-I/O	SDA	2-wire Serial interface data	2
13		GND	Module Ground	1
14	CML-O	RX3+	Receiver non-inverted data output	
15	CML-O	RX3-	Receiver inverted data output	
16		GND	Module Ground	1
17	CML-O	RX1+	Receiver non-inverted data output	
18	CML-O	RX1-	Receiver inverted data output	
19		GND	Module Ground	1
20		GND	Module Ground	1
21	CML-O	RX2-	Receiver inverted data output	
22	CML-O	RX2+	Receiver non-inverted data output	
23		GND	Module Ground	1
24	CML-O	RX4-	Receiver inverted data output	
25	CML-O	RX4+	Receiver non-inverted data output	
26		GND	Module Ground	1
27	LVTTL-O	ModPrsL	Module Present, internal pulled down to GND	
28	LVTTL-O	IntL	Interrupt output, should be pulled up on host board	2
29		VCCTx	+3.3v Transmitter Power Supply	
30		VCC1	+3.3v Power Supply	
31	LVTTL-I	LPMODE	Low Power Mode	2
32		GND	Module Ground	1
33	CML-I	Tx3+	Transmitter non-inverted data input	
34	CML-I	Tx3-	Transmitter inverted data input	
35		GND	Module Ground	1
36	CML-I	Tx1+	Transmitter non-inverted data input	
37	CML-I	Tx1-	Transmitter inverted data input	
38		GND	Module Ground	1

Notes:

1. Module circuit ground is isolated from module chassis ground with in the module.
2. Open collector; should be pulled up with 4.7k-10k ohms on host board to a voltage between 3.15V and 3.6V.

Electrical Pin-out Details

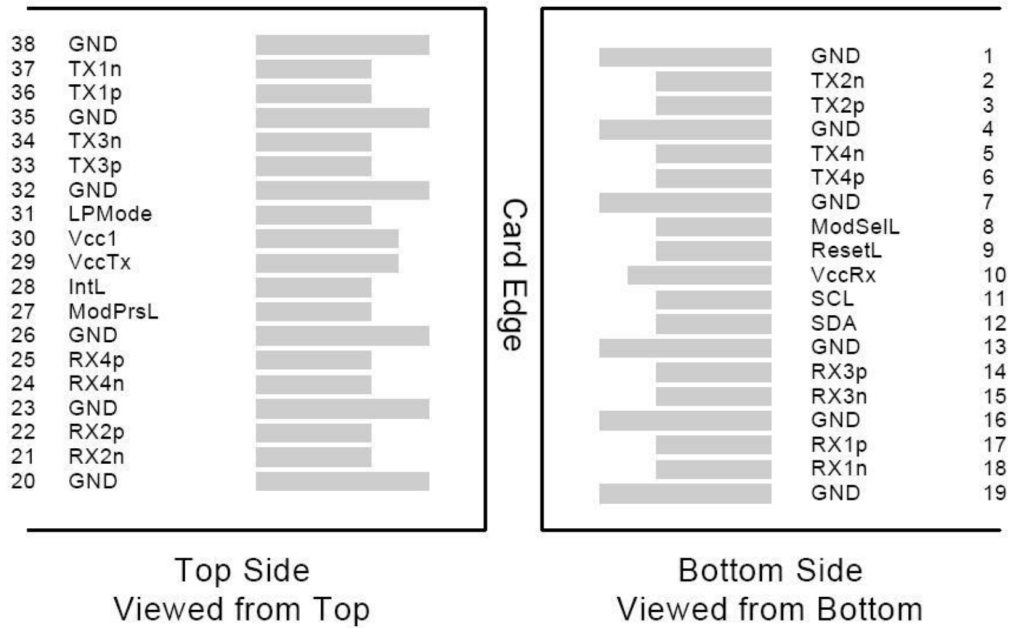

Transceiver Block Diagram

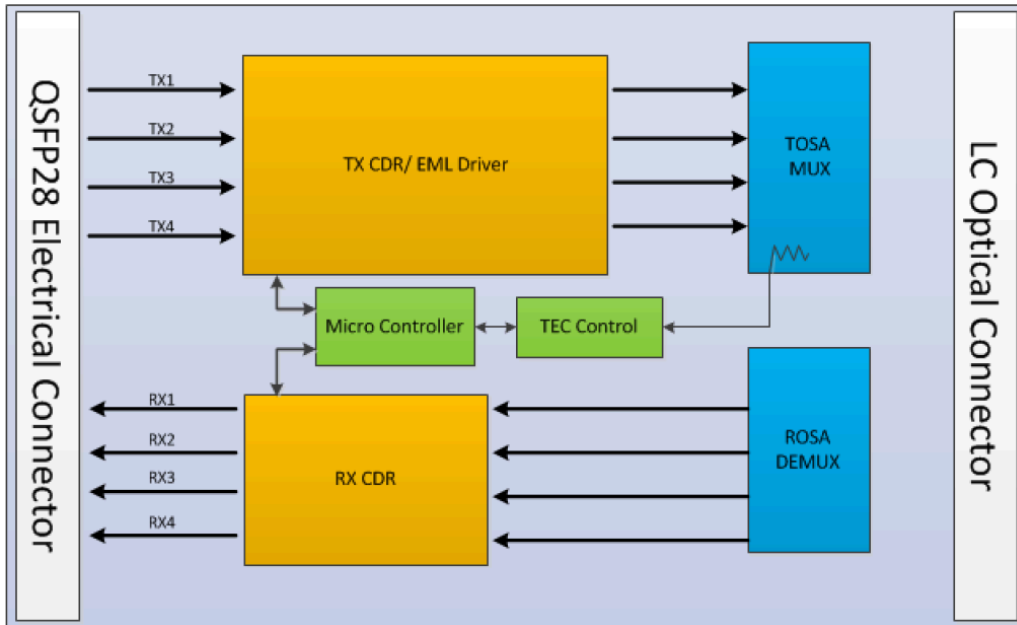

Mechanical Specifications

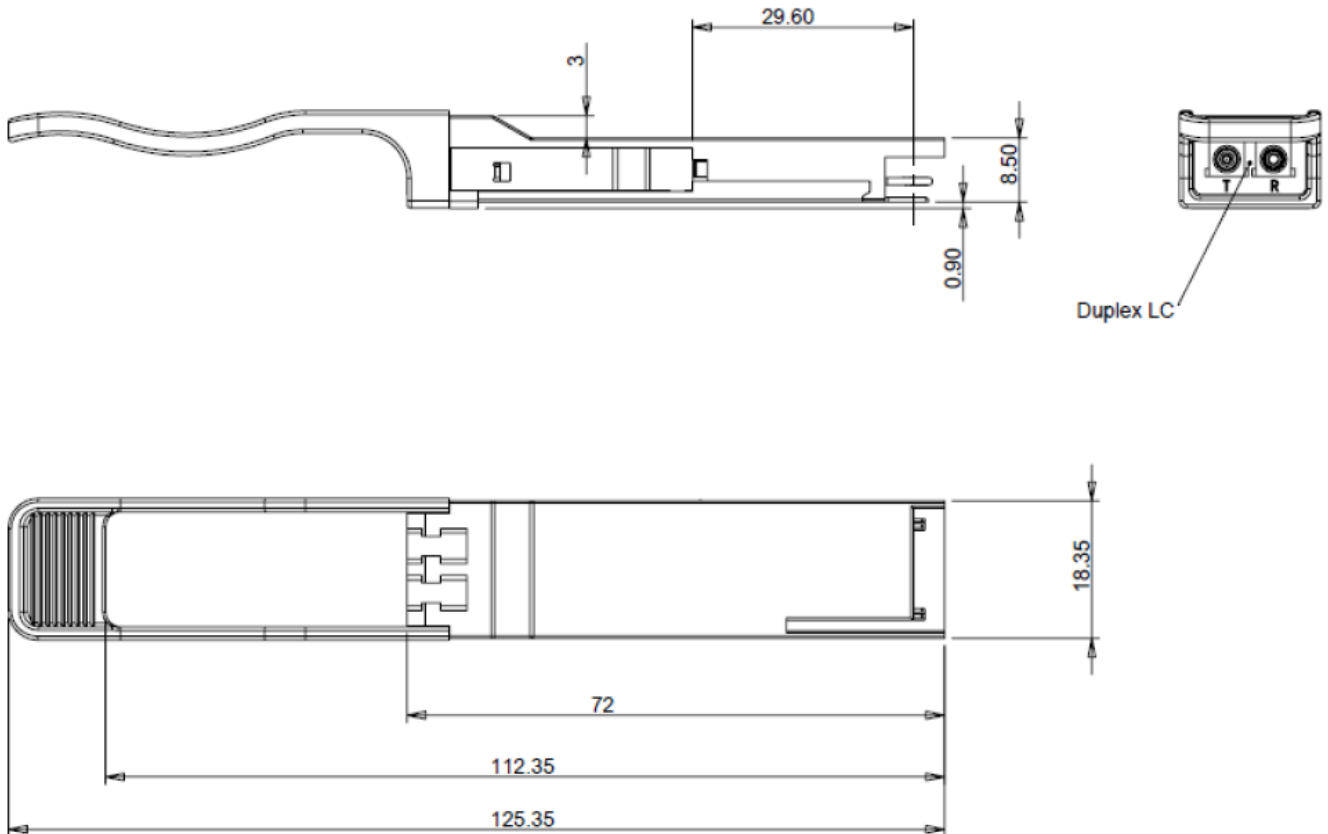

Contact Information

Founded in 1999, AddOn Networks is North America's leading provider of transceivers and high speed cabling. With a reputation for high quality products as well as an extensive custom design portfolio, AddOn has the connectivity solution regardless of the requirement.

At AddOn, 100% of the products we ship every day are tested in the specific application for which they are intended—never batch or spec tested only. We run bandwidth, distance and IOS network tests. We have documented an impressive 0.03% failure rate over the last 10 years. To continue this rate of success we invest millions annually in our own on-site testing lab.

Corporate office:
AddOn Networks
15775 Gateway Circle
Tustin, CA 92780

Tel: 877-292-1701
Fax: 949-266-9273
Email: sales@addonnetworks.com
Email: support@addonnetworks.com
Web: <http://www.addonnetworks.com>