

CONVERSION TABLES

Foot Pounds (ft.lbs)	Kilo-gram Meters (Kgm or mkp)	Newton Meters (Nm)	Newton Meters (Nm)	Foot Pounds (ft.lbs)	Kilo-gram Meters (Kgm or mkp)	Kilo-gram Meters (Kgm or mkp)	Newton Meters (Nm)	Foot Pounds (ft.lbs)
5	0.69	6.78	10	7.38	1.02	1	9.81	7.23
10	1.38	13.56	20	14.75	2.04	2	19.61	14.47
15	2.07	20.34	30	22.13	3.06	3	29.42	21.70
20	2.76	27.12	40	29.50	4.08	4	39.23	28.93
25	3.46	33.90	50	36.88	5.10	5	49.04	36.17
30	4.15	40.68	60	44.26	6.12	6	58.54	43.40
35	4.84	47.46	70	51.63	7.14	7	68.65	50.63
40	5.53	54.24	80	59.01	8.16	8	78.46	57.87
45	6.22	61.02	90	66.38	9.18	9	88.26	65.10
50	6.91	67.80	100	73.76	10.20	10	98.07	72.33
55	7.60	74.58	110	81.14	11.22	11	107.88	79.57
60	8.29	81.36	120	88.51	12.24	12	117.68	86.80
65	8.98	88.14	130	95.89	13.26	13	127.49	94.03
70	9.67	94.92	140	103.26	14.28	14	137.30	101.27
75	10.37	101.70	150	110.64	15.30	15	147.11	108.50
80	11.06	108.48	160	118.02	16.32	16	156.91	115.74
85	11.75	115.26	170	125.39	17.34	17	166.72	122.97
90	12.44	122.04	180	132.77	18.36	18	176.53	130.20
95	13.13	128.82	190	140.14	19.38	19	186.33	137.43
100	13.82	135.60	200	147.52	20.40	20	196.14	144.67
105	14.51	142.38	210	154.90	21.42	21	205.95	151.90
110	15.20	149.16	220	162.27	22.44	22	215.75	159.13
115	15.89	155.94	230	169.65	23.46	23	225.37	166.37
120	16.58	162.72	240	177.02	24.48	24	235.37	173.60
125	17.28	169.50	250	184.40	25.50	25	245.18	180.84
130	17.97	176.28	260	191.78	26.52	26	254.98	188.08
135	18.66	183.06	270	199.15	27.54	27	264.79	195.30
140	19.35	189.84	280	206.53	28.56	28	274.60	202.54
145	20.04	196.62	290	213.91	29.58	29	284.41	209.77
150	20.73	203.40	300	221.29	30.60	30	294.22	217.00
155	21.42	210.18	310	228.67	31.62	31	304.03	224.23
160	22.11	216.96	320	236.05	32.64	32	313.84	231.46
165	22.80	223.74	330	243.43	33.66	33	323.65	238.69
170	23.49	230.52	340	250.81	34.68	34	333.46	245.92
175	24.19	237.30	350	258.19	35.70	35	343.27	253.15
180	24.88	244.08	360	265.57	36.72	36	353.08	260.38
185	25.57	250.86	370	272.95	37.74	37	362.89	267.61
190	26.26	257.64	380	280.33	38.76	38	372.70	274.84
195	26.95	264.42	390	287.71	39.78	39	382.51	282.07
200	27.64	271.20	400	295.09	40.80	40	392.32	289.30
205	28.33	277.98	410	302.47	41.82	41	402.13	296.53
210	29.02	284.76						
215	29.71	291.54						
220	30.40	298.32						
225	31.09	305.10						
230	31.78	311.88						
235	32.47	318.66						
240	33.16	325.44						
245	33.85	332.22						
250	34.54	339.00						
260	35.88	352.56						
270	37.22	366.12						
280	38.56	379.68						
290	40.00	393.24						
300	41.44	406.80						

CONVERSION FORMULAS

1 CMKG = 13.883 IN-OZ	1 dNm = 14.161 IN-OZ
1 CMKG = 0.8677 IN-LB	1 Nm = 8.8507 IN-LB
1 MKG = 7.233 FT-LB	1 Nm = 0.73756 FT-LB
1 CMKG = 1 CMKG	1 KpM = 1 MKG
1 CMKG = 0.098 Nm	1 MKG = 9.80665 Nm

Purchased at: _____

Date: _____

ADJUSTMENT OF TORQUE SETTING

READ, UNDERSTAND AND FOLLOW ALL INSTRUCTIONS AND WARNINGS BEFORE OPERATING THIS TOOL. FAILURE TO DO SO MAY RESULT IN PERSONAL INJURY AND/OR PROPERTY DAMAGE AND WILL VOID WARRANTY.



HOW TO USE YOUR NEW TORQUE WRENCH

- Balancing wrench in hand with graduations visible unlock knurled handle by turning lock nut counter-clockwise. (see fig. 1)
- Set amount of torque required by turning knurled handle to read exact amount on barrel graduations. Example: 114 ft. lbs.
 - Turn knurled handle clockwise until the 0 ft. lbs. graduation on the beveled edge of the handle is lined up with the vertical mark on the barrel and is even with the 110 ft. lbs. graduations. (see fig. 2)
 - Continue turning handle clockwise until the 4 ft. lbs. graduation on the beveled edge of the handle is in line with the vertical line on the barrel. (see fig. 3)
 - Lock knurled handle securely by turning lock nut clockwise. Wrench is now set at 114 ft. lbs. and is ready to use.
- When setting for metric (Nm), use the same procedures as setting for ft. lbs. using the Nm measurements on the opposite side of the barrel.
- Install the proper socket or attachment to the square drive and apply to nut or bolt and pull handle until you feel and/or hear wrench click. Release, pull off and wrench automatically resets for the next operation.

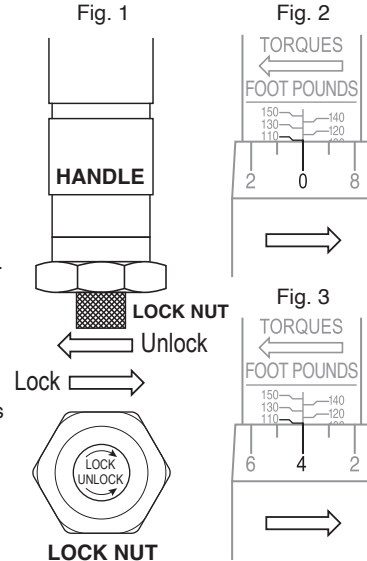

SAFETY GUIDELINES, WARNINGS AND PRECAUTIONS

CAUTION: DO NOT CONTINUE TO PULL AFTER WRENCH RELEASES. USE SPECIAL CARE AT LOW TORQUE SETTINGS THAT PULL STOPS WHEN WRENCH CLICKS.

- If wrench has not been used or has been in storage for some time, operate it several times at a low torque setting which permits special internal lubricants to recoat internal working parts

NOTE: When wrench is not in use, keep adjustment at lowest torque setting.

- Do not turn handle below lowest torque setting.
- Do not continue pulling on the wrench after pre-set torque has been reached and the wrench has released. Pressure must be taken off the handle and the wrench allowed to automatically reset itself. Continuing to apply pressure after the wrench has released, will result in damage to the part being torqued by applying more than the specified amount of torque.
- Tool is rugged and designed for shop use, but is also a precision measuring instrument and should be treated as such.
- Clean wrench by wiping with a cloth. Do not immerse in any type of cleaner which may affect special high pressure lube with which the wrench is packed at the factory.
- This torque wrench was calibrated and tested before leaving the factory and is accurate to $\pm 4\%$.

THIS IS A PRECISION MEASURING INSTRUMENT, CALIBRATION AND SERVICING MUST BE DONE REGULARLY AND IS THE OWNER'S RESPONSIBILITY.