

sealersales

OPERATION AND PARTS MANUAL

KSFS-SERIES

AUTO FOOT IMPULSE SEALER

MODEL NO: KS-FS455, KS-FS605, KS-FS805

8820 BAIRD AVENUE; NORTHRIDGE, CA 91324

PHONE: 818.718.8818 | WWW.SEALERSALES.COM

VERSION 1.2
LAST UPDATED: 06/04/26



SCAN ME

General Information

Thank you for purchasing our KS-FS Automatic Foot Sealers

This owner's manual contains information relating to your foot sealer. The manual will provide you with basic information concerning both operation and maintenance of your new machine. Please read it carefully as failure to do so may result in bodily injury and/or damage to the equipment.

Please fill in the information below. You will find the information on the machine identification plate. You will need this information when ordering replacement parts or making technical inquiries.

No part of this manual may be duplicated, reproduced, stored in a retrieval system, translated, transcribed, or transmitted in any form without the express prior written permission of Sealer Sales.

KS - FS EQUIPMENT INFORMATION

❖ Model #

❖ Serial #

❖ Purchase Date:

❖ Reference # (found on packing slip)

❖ Owner:

Table of Contents

Safety Instructions	1
Introduction.....	3
Operating your Foot Sealer	6
Maintenance	8
Parts Diagram.....	11
Troubleshooting	14
Spare Parts List	15

Safety Instructions



WARNING! Below are general safety precautions and warnings that should be understood prior to setting up or operating your equipment. Read and fully understand all instructions and warnings prior to using this unit. Your safety is most important! Failure to comply with procedures may result in serious injury or property damage. Remember: **Your personal safety is your responsibility.**

Unsafe practices or unauthorized modifications could result in accidents or property damage. Failure to follow these safety rules and take necessary precautions can result in serious injury as well as damage to equipment.

- ❖ Never operate or service your sealer until you have read this manual completely and understand it fully.
- ❖ Plug the sealer into a standard 120 Volt, 60Hz wall outlet or surge protector.
- ❖ Do not use the sealer if the power cord, plug or any other parts are damaged. Be sure not to allow the power cord to drape into your work area. Check that all parts are operating properly and perform the intended functions. Check for any worn parts before starting operation. Check for all other conditions that may affect the operation.
- ❖ Reduce risk of unintentional starting. Make sure the power switch is in the "OFF" position before attaching to the power source.
- ❖ Always disconnect sealer from power source before servicing, changing accessories or cleaning the unit.
- ❖ To provide protection against the risk of electrical shock, the power connection must be properly grounded at all times.
- ❖ Do not leave the sealer unattended when in use. Disconnect the sealer from the power source before leaving the work area.
- ❖ Sealer is used solely for sealing thermoplastic materials. Using the machine for any other purpose can cause damage to the machine and operator. Do NOT use the machine for any other purpose other than to seal thermoplastic materials. Doing so may result in damage to the machine and injury to the operator.
- ❖ While operating machinery, wear close-fitting clothing and tie back long hair to prevent any external items from getting caught in the machine. Do not wear jewelry when operating the sealer.



- ❖ Never touch the heating elements with bare hand while the sealer is plugged into a power source, in operation or just finished operation. Touching heated areas may cause fire and/or severe burns.
- ❖ While machine is in operation, do not place fingers, tools, or other foreign objects on or into the machine. Do not place hands or fingers near pinch points. Do not touch machine while it is in operation. Perform all procedures carefully and watch where hands and fingers are at all times.
- ❖ The sealer is not water resistant or water proof. Spraying down the machine will damage machine or cause electrical shock. Do not submerge the sealer into water or liquid.
- ❖ Do not operate sealer in a corrosive or humid environment.
- ❖ Always keep the machine clean, lubricated and in good working condition. Follow any maintenance and lubrication procedures outlined in this manual. Make sure unit is disconnected from power source before cleaning.
- ❖ NEVER use any accessories or parts from other manufacturers. Machine should not be altered or modified using parts that are not genuine authorized parts. Doing so will VOID YOUR WARRANTY.
- ❖ Never leave the sealer unattended. Be safe, disconnect the sealer from power source before leaving work area.
- ❖ Always keep out of reach of children and pets.
- ❖ Close supervision is necessary when any appliance is near persons with reduced physical, sensory or mental capabilities or lack of experience and knowledge . This sealer is NOT to be used by children or by persons with reduced physical, sensory or mental capabilities or lack of experience and knowledge.
- ❖ Do NOT use the sealer outdoors.
- ❖ Do NOT use the sealer while under the influence of drugs, medications or alcohol.

SAVE THESE INSTRUCTIONS - REFER TO THEM OFTEN AND USE THEM TO INSTRUCT OTHERS.

Introduction

KS-FS Series sealers are automatic foot sealers ideal for high volume poly bag and other thermoplastic sealing. The sealer allows you to keep both hands free for quicker and more accurate sealing. Our KS-FS foot sealers can seal polyethylene, polypropylene, saran, nylon, static shielding bags, Mylar up to 20mil in total thickness.

Features of the KS-FS Automatic Foot Sealers

Your foot sealer is equipped with a wide range of standard features and capabilities.

- ❖ Impulse sealing - no warm up time needed
- ❖ Digital display
- ❖ Dual mode operation: auto or manual
- ❖ Die cast construction
- ❖ Foot switch allows hands free operation
- ❖ Standalone unit with no need for counter
- ❖ Wider 5mm (.20") seal width
- ❖ Adjustable work table height
- ❖ Max heat time: 1.8sec / Max cool time: 5.0sec
- ❖ Manufacturer spare parts kit includes: 2 heating elements and one PTFE (upper barrier) cloth and one 8A fuse

How Do KS-FS Foot Sealers Work?

Basic

Principles

Place material on
lower jaw and
activate footswitch

Our KS-FS impulse sealers fire a short burst of electricity through a specially designed heating wire to seal the inner walls of bags. The length of the seal time will depend on the sealing characteristics of the bag being sealed. The sealing process is simple: The operator places the bag between the sealing jaws and presses the footswitch to activate the unit. The sealer is equipped with a digital display for easy timer settings. The seal process ends automatically once the preset seal time is reached. The operator retrieves the sealed bag and repeats the process. Bags are sealed repeatedly and uniformly.

Specifications

	KS-FS455	KS-FS605	KS-FS805
Power	110V/60Hz		
Watts	1050W	1300W	1500W
Seal Width	5mm		
Sealing Length	17.7"	23.6"	31.5"
Net Weight	75lbs	83lbs	88lbs
Gross Weight	118lbs	130lbs	136lbs
Shipping Dimensions	36" x 24" x 20"	36" x 24" x 20"	b

Getting to Know your Foot Sealer

KS-FS Foot Sealers are simple and efficient sealing machines.

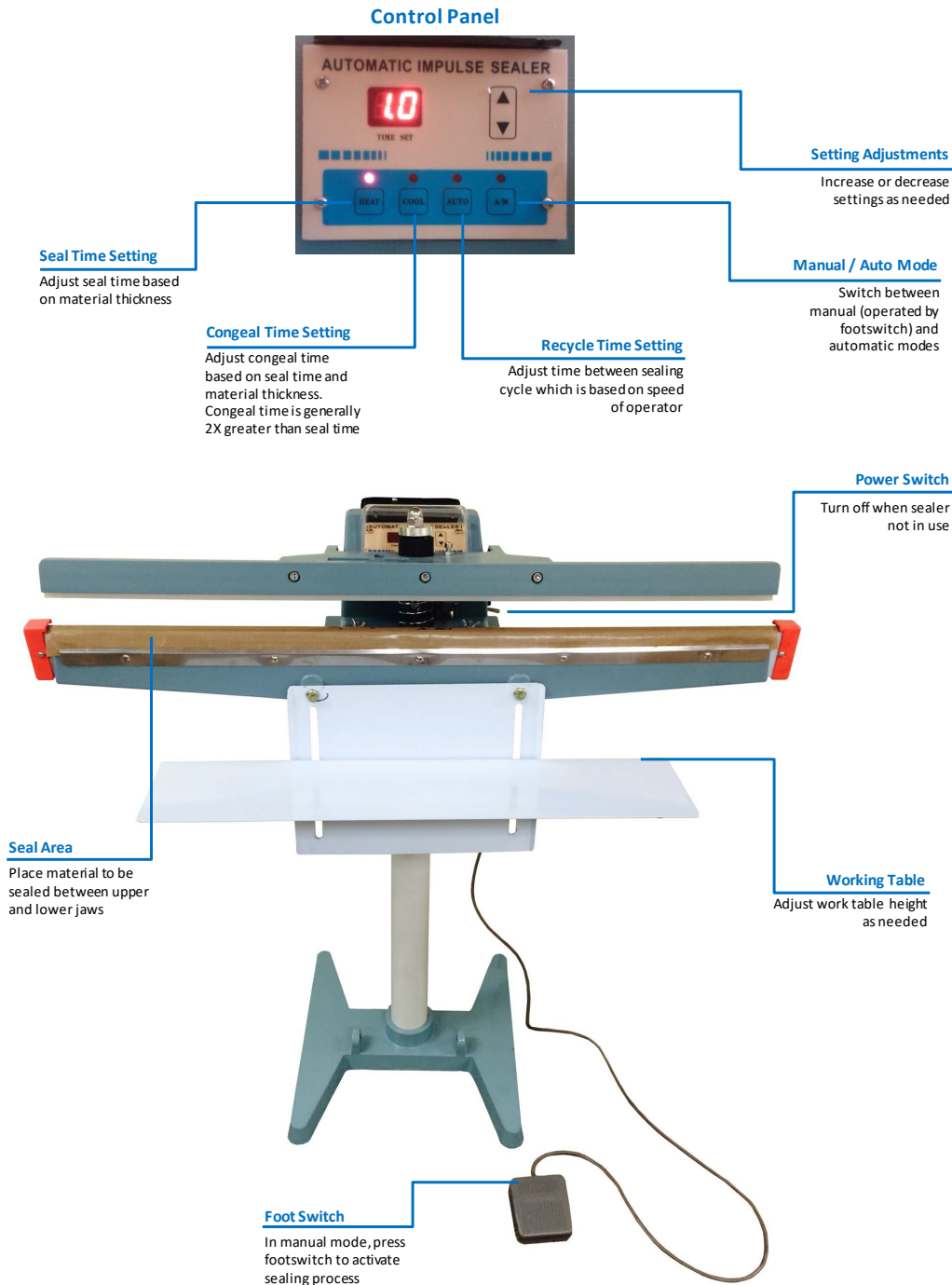

Figure 1. KS-FS Foot Sealer Overview

Operating your Sealer

Assembly Instructions

1. Insert standing tube (**Figure 8, Item #7**) into the pedal base (**Figure 8, Item #1**) and connect with a screw. Make sure the side with two screw holes is facing upwards.
2. Place sealing head in the tube and screw in place using the two long screws (**Figure 8, Item #8-10, 13**).
3. Optional: Connect working plate to body using two working bolts. Affix the working table using the two remaining working bolts.
4. Plug foot switch in the foot switch receptacle found at the back of the machine.

Operation



1. Before operating, check the heating element, PTFE cover, PTFE adhesive and the silicone rubber.
2. Insert the power cord into the correct receptacle (110V).
3. Turn the power switch on found on the side of the sealer head.



Figure 2. KS-FS Timer Control Panel

4. The red light above the HEAT button should be on. Use the default settings (lowest setting) and increase gradually as needed. Thicker bags will need a higher setting.
5. Press the COOL button and adjust settings as necessary. The COOL button determines the congealing time for the sealing. For a high quality seal, seals must be able to cool under pressure. We usually recommend a congeal setting of at least

2x that of the heat setting but every bag will have variations. Thicker materials will require a longer cool (congealing) time.

6. Press the AUTO button to adjust recycle settings when the sealer is in automatic mode. This will determine the time between each seal cycle. Please disregard the AUTO button when using the sealer in manual mode.
7. Choose the appropriate mode: manual or auto. Press the A/M button to rotate between the two modes.
 - a. For manual operation, place the material to be sealed under the sealing arm and press the foot switch to activate the upper sealing jaw.
 - b. For auto operation, press the A/M button to activate automatic sealing. To turn off the automatic mode and return to manual mode, press the A/M button. Auto mode is when the upper sealing jaw will open and close automatically based on the HEAT, COOL, and AUTO settings.

Tips for Successful Sealing

1. If the seal is broken or damaged, decrease the sealing time.
2. If the seal is not fully welded, increase the sealing time.
3. If the sealing material sticks to the sealing pad, decrease the congealing time.
4. If the width of the seal is not perfect or does not match the size of the element, increase the congealing time.
5. Always keep the sealer clean. Remove any residue found on the platform and PTFE cover. Silicone spray may be used for this purpose.



6. ***When replacing the heating elements, always replace the PTFE adhesive under the heating element. A worn PTFE adhesive can cause the heating element to break.*** The PTFE adhesive works as a barrier between the body of the sealer and the element. Never allow the element to come in direct contact with the sealer body as that will damage the timer.
7. Occasionally check the condition of the silicone rubber for wear or burns. A damaged silicone rubber will affect the quality of the seal.



8. Be sure to turn off the power or unplug the unit before replacing any parts.

Maintenance

The following maintenance procedures should be followed to ensure the longevity of your KS-FS foot sealer.

Inspection and Cleaning

1. Inspect your machine daily.
2. Use a clean cloth to remove any plastic residue remaining on the PTFE cloth.
3. When replacing the elements, always check the condition of the bottom PTFE tape.
4. Check the condition of the silicone rubber for wear and burns. A damaged silicone rubber will affect the quality of the seal.

Replacement Kit Instructions

Our KS-FS impulse sealers will require new heating elements and PTFE from time to time. Heating elements will break through wear and tear. A good rule of thumb is to replace the PTFE adhesive every time you change your heating element. The PTFE cover prevents the plastic or other thermoplastic material you are sealing from sticking to the heating element.

Replacement kits are available from your distributor. Kits include (2) heating elements, (2) PTFE adhesives, and 1ft long roll of PTFE cover. For replacement kit part #s, refer to your model #.

	KS-FS455	KS-FS605	KS-FS805
Replacement Kit	RK-18F5-KS-FS455	RK-24F5-KS-FS605	RK-32F5-KS-FS805
	5mm		
Heating Element	HE-18-5-KS-FS455	HE-24-5-KS-FS605	HE-32-5-KS-FS805
PTFE Adhesive	TA-18	TA-24	TA-32
PTFE Cloth	TR-18-12	TR-24-12	TR-32-12
Silicone Rubber (not included in RK)	SR-KS-FS455	SR-KS-FS605	SR-KS-FS805

To install your replacement kit on your sealer, turn off power and unplug sealer.

Removing Worn Parts.

1. Loosen the screws on the PTFE cover plate ([Figure 8, Item #56](#)). Remove the heating element cover.
2. Lift up the PTFE cover to expose the heating element ([Figure 8, Item #53](#)).



Figure 3. Loosen screws on PTFE plate.

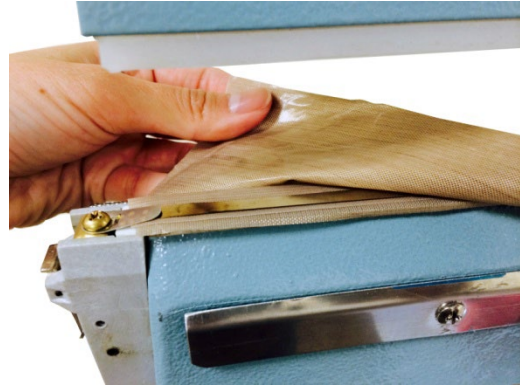

Figure 4. Pull PTFE cover to expose heating element.

3. Remove the heating element by unscrewing the element screw (**Figure 8, Item #50**) (apply pressure to the heating element with your finger while unscrewing the screw to prevent the heating element from twisting).
4. Peel off the PTFE adhesive under the heating element.

Installing New Replacement Parts.

1. Remove the backing of the liner found on the PTFE adhesive.
2. Apply it to the sealer's sealing platform. The PTFE adhesive must always extend past the sealing platform by approximately $\frac{1}{4}$ " to $\frac{1}{2}$ " on both ends. Bend down the excess on both ends. (The PTFE adhesive acts a barrier between the metal body and the heating element. Never allow the heating element to come in direct contact with the sealer's body because it will damage the timer.)
3. Place a new element on top of the PTFE adhesive by screwing the element in the heating terminal assembly block. To attach the element to the other side, lift the latch found on the heating terminal block to push the block inward and securely screw the element to the block. Check the elements to ensure it is tight and intact.

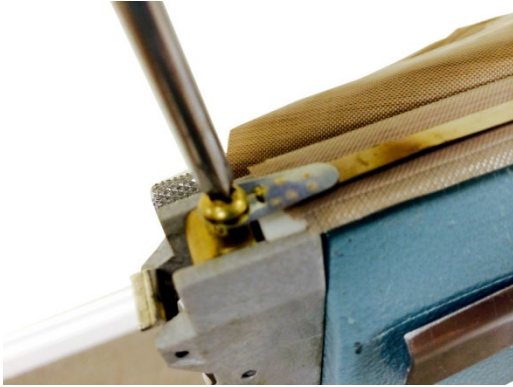

Figure 5. Screw element in place

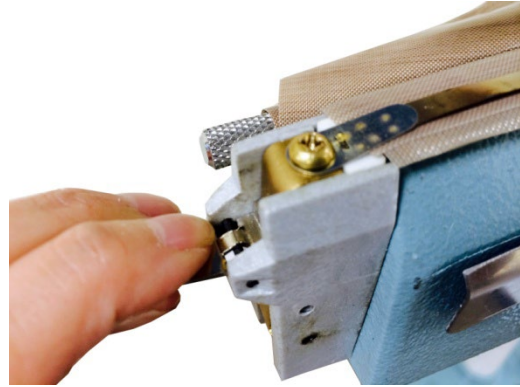

Figure 6. Lift latch on heating block to screw element in place.

4. Cut off any worn out PTFE cover. Ease out enough footage of PTFE cover to cover the heating element and extend to the front of the PTFE cover plate.
5. Tighten the screws to affix the PTFE cover plate.
6. If a whole roll of PTFE cover needs to be replaced, loosen the wing nut (**Figure 8, Item #46**) found on the plate for PTFE (**Figure 8, Item #47**) and remove the PTFE roller (**Figure 8, Item #48**). Tape one end of the PTFE cover to the rod and roll up the entire piece. Position the PTFE cover and rod using the plate for PTFE. Ease out enough footage of PTFE cover to cover the heating element and extend to the front of the PTFE cover plate.



Figure 7. Screw element in place

Parts Diagram

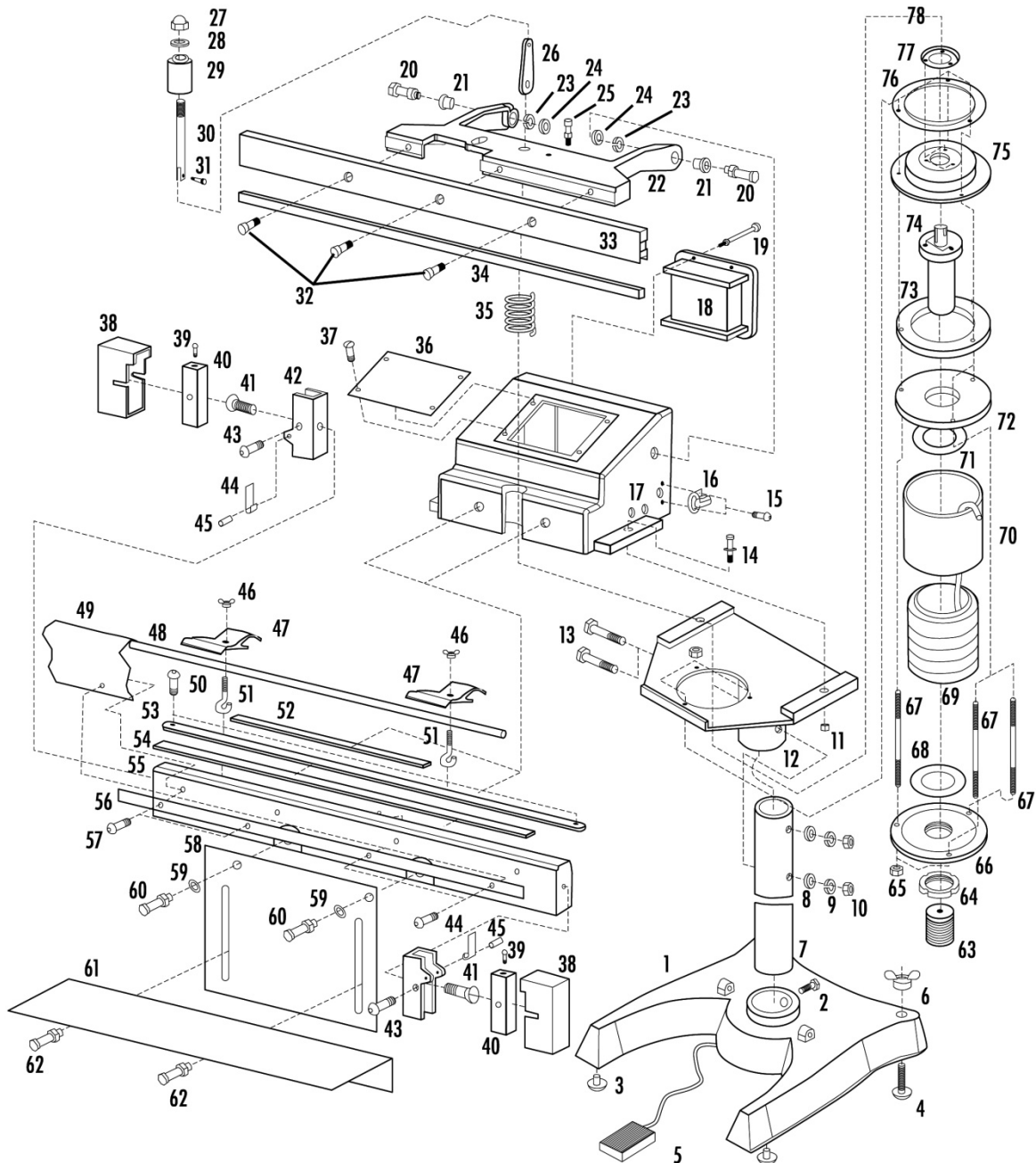

Figure 8. Spare Parts Diagram Overview

Figure 9. Spare Parts Diagram Overview

Item	Part #	Description	Comments
1		Machine Base	
2		Bolt	
3	KSFS-3	Rubber Washer	
4		Foot Screw	
5		Pedal Switch	
6		Butterfly Nut	
7	KSFS-7	Standing Tube	
8		Pin Washer	
9		Spring Washer	
10		Lock Nut	
11		Connecting Nut	
12		Sealing Jaw Base	
13		Connecting Bolt	
14		Connecting Bolt	
15		Wire Protection Bolt	
16		Wire Protection	
17		Sealing Jaw	
18		Big Transformer	
19	KSFS-19	Transformer Bolt	
20		Connecting Bolt for Sealing Frame	
21		Washer	
22		Upper Sealing Frame	Special Order Only
23		Spring Washer	
24		Pin Washer	
25	KSFS-25	Proximity Switch Bolt	
26	KSFS-26-31	Connecting Board	Includes Parts #26-31
27	KSFS-26-31	Cap Nuts	Includes Parts #26-31
28	KSFS-26-31	Washer	Includes Parts #26-31
29	KSFS-26-31	Rubber Washer	Includes Parts #26-31
30	KSFS-26-31	Rubber Washer	Includes Parts #26-31
31	KSFS-26-31	Pole	Includes Parts #26-31
32		Fixing Screw of Upper Sealer	
33		Upper Sealer	
34	SR-specifymodel#	Silicone Rubber	
35	KSFS-35	Spring	
36	T-KSFS	Operation Panel	
	KSFS-36A-Cover	Clear Cover for Timer	
37		Fixing Bolt	
38	HTAB-KSFS or KSFS-38	Heating Terminal Assembly Cover	Includes Parts #38-45
39	HTAB-KSFS	Fixing Bolt	Includes Parts #38-45
40	HTAB-KSFS	Fixing Copper Block	Includes Parts #38-45
41	HTAB-KSFS	Front Protection Cover Bolt	Includes Parts #38-45
42	HTAB-KSFS	Front Protection Cover	Includes Parts #38-45
43	HTAB-KSFS	Copper Block Bolt	Includes Parts #38-45
44	HTAB-KSFS	Adjusting Block	Includes Parts #38-45
45	HTAB-KSFS	Round Bolt	Includes Parts #38-45

Figure 10. Spare Parts Diagram Overview

Item	Part #	Description	Comments
46	KSFS-46	Wing Nut for PTFE Sheet	
47	KSFS-47	Plate for PTFE Sheet	
48	KS-FS-455-48 KS-FS-605-48 KS-FS-805-48	Iron Stick / PTFE Roller	
49	TR-18-12 - KS-FS-455 TR-24-12-KS-FS-605 TR-32-12-KS-FS-805	PTFE - 1Ft Long, 5 mil	
50	KSFS-50	Heating Element Bolt	
51	KSFS-51	Locking Screw	
52		Pressing Board	
53	HE-18-5-KS-FS-455 HE-24-5-KS-FS-605 HE-32-5-KS-FS-805	Heating Element	
54	TA-18 TA-24 TA-32	PTFE Adhesive, 1/2", 6mil	
	KS-FS-455-54-1 KS-FS-605-54-1 KS-FS-805-54-1	Acrylic Plate (under PTFE Adhesive)	not shown
55	KS-FS-455-55 KS-FS-605-55 KS-FS-805-55	Base	
56	KS-FS-455-56 KS-FS-605-56 KS-FS-805-56	PTFE Cover Plate	
57	KSFS-57	Pressing Board Bolt	
58		Vertical Flat Pad	
59		Washer	
60		Locking Bolt	
61		Horitzontal Flat Pad	
62		Flat Pad Bolt	
63	KSFS-63	Adjusting Screw	
64	KSFS-64-65	Locking Nut	Includes parts #64, 65
65	KSFS-64-65	Cap	Includes parts #64, 65
66		Lower Flange	
67		Screw Pole	
68		Rubber Washer	
69		Wire	
70		Shell	
71		Upper Washer	
72		Lower Washer	
73		Upper Locking Ring	
74	KSFS-74	Axis / Mandrel	
75	KSFS-75	Rubber Cap	
76		Pressing Ring	
77	KSFS-77-78	Locking Ring	Includes parts #77, 78
78	KSFS-77-78	Locking Nut	Includes parts #77, 78
79	KSFS-79	Small Transformer	not shown
80	KSFS-80	Switch Board (Interlocking Set)	not shown

Troubleshooting

Problem	Possible Causes	Solution
No sealing Timer lights off	<ol style="list-style-type: none"> 1. Disconnected power cord 2. Power cord is broken 3. Blown fuse 4. Transformer is broken 	<ol style="list-style-type: none"> 1. Check or change plug 2. Replace power cord 3. Replace fuse 4. Replace the transformer
No sealing Timer lights are on	<ol style="list-style-type: none"> 1. Heating element is broken 2. Poor contact at heating terminal blocks 	<ol style="list-style-type: none"> 1. Replace the heating element 2. Clean, tighten or change the heating terminal blocks
No sealing Power light on Heat indicator off	<ol style="list-style-type: none"> 1. Footswitch malfunction 2. Microswitch malfunction 3. Microswitch out of place 	<ol style="list-style-type: none"> 1. Replace footswitch 2. Replace microswitch 3. Adjust microswitch
Burnt PTFE cloth	<ol style="list-style-type: none"> 1. Timer malfunction 2. Timer setting too high 	<ol style="list-style-type: none"> 1. Replace timer 2. Decrease timer setting
Broken heating element	<ol style="list-style-type: none"> 1. Worn PTFE adhesive 	<ol style="list-style-type: none"> 1. Replace PTFE adhesive
Wrinkled seal	<ol style="list-style-type: none"> 1. Seal time is set too high 2. Cooling (congeal) time is too short 	<ol style="list-style-type: none"> 1. Decrease 2. Increase congealing time
Imperfect seal	<ol style="list-style-type: none"> 1. Worn PTFE cloth 2. Worn silicone rubber 	<ol style="list-style-type: none"> 1. Replace PTFE cloth 2. Replace the silicone rubber
Burnt seal	<ol style="list-style-type: none"> 1. Seal time is set too high 	<ol style="list-style-type: none"> 1. Decrease seal time
No seal	<ol style="list-style-type: none"> 1. Seal time is set too low 	<ol style="list-style-type: none"> 1. Increase seal time
Seal sticking to PTFE cloth	<ol style="list-style-type: none"> 1. Worn or dirty PTFE cloth 2. Worn or dirty silicone rubber 	<ol style="list-style-type: none"> 1. Replace or clean PTFE cloth 2. Replace or clean silicone rubber

Spare Parts List

Included with imprinter are the following parts. Please note that spare parts included with your foot sealer are subject to change without notice.

- ❖ Instruction manual
- ❖ Foot switch (Part#FS-KS-FS)
- ❖ 2 - Heating Elements
- ❖ 1 - Roll of PTFE cover
- ❖ 1 - Wrench (6" / 150mm)
- ❖ 1 - Flat screwdriver
- ❖ 1 - Philips screwdriver
- ❖ 1 - 8amp fuse