

Ordering Information

Ordering

The 3VA breakers are shipped complete with non-interchangeable trip units and without lugs.

The 3VA41 panelboard mounted circuit breakers are shipped with aluminum load side lugs installed as standard.

3VA51 through 3VA55 thermal-magnetic trip breakers as well as 3VA61 through 3VA66 electronic trip breakers are shipped as standard without lugs installed. To order factory installed nut keepers, which are required for installation in panelboards or switchboards, the 12th digit of the catalog should be change to "2" when ordering. (For example, a 35KA@480VAC, 40A, 3-pole, 3VA51 with lugs would be catalog number 3VA5140-5ED32-0AA0).

To order factory installed standard line and load lugs, the 12th digit of the catalog number should be changed to "6" (standard lugs are identified in the respective lug tables and footnotes in the SpeedFax). (For example, a 35KA@480VAC, 40A, 3-pole, 3VA51 with lugs would be catalog number 3VA5140-5ED36-0AA0). Alternate connectors can be ordered separately for field installation.

All 3VA6 circuit breakers are certified to UL 489 Supplement SB, are marked "NAVAL", and are suitable for use at 50C.

To order NAVAL-rated thermal-magnetic trip circuit breakers, the 13th digit of the catalog number should be changed to the number "1". (For example, a 35KA @480VAC, 40A, 3-pole, NAVAL rated 3VA51 would be catalog number 3VA5140-5ED31-1AA0).

All 3VA5 thermal-magnetic trip and 3VA6 electronic trip circuit breakers are UL listed for reverse feed applications.

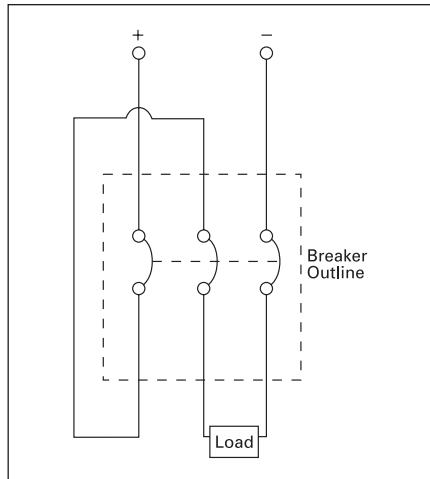

500V DC Wiring Configuration

Connecting Breakers for DC Application

Most Siemens thermal magnetic trip MCCBs are applicable on direct current (dc) systems. Generally, for 250 V dc systems a two pole breaker is used, with one pole on each leg of the supply circuit. For three pole breakers applied on 500 V undergrounded DC systems, it is important to connect the power supply "zig-zag" through the breaker as shown in the figure below. This assures that the Voltage between phases on the breaker terminals is uniformly distributed.

See below for an alternative connection diagram. For a list of 3VA5 breakers with the DC ratings, please refer to pages 7-10 to 7-11.

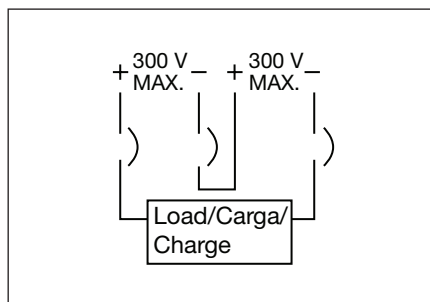

3VA Molded Case Circuit Breakers

3VA UL Breakers

Catalog Numbering System

Catalog Numbering Logic

3VA 6 1 40 5 HL 3 1 0 A A0

Breaker Designation	
Thermal magnetic panelboard breakers	4
Thermal magnetic (Cable-in Cable-out) breakers	5
Electronic trip breakers	6

Frame Size	
125/150A	1
250A	2
400A	3
600A	4
800A	5
1000A	6

Rated Current											
3VA41/ 3VA51	3VA52	3VA53	3VA54	3VA55	3VA61	3VA62	3VA63	3VA64	3VA65	3VA66	
15A											95
20A	200A	200A									20
	225A	225A									22
25A	250A	250A				250A	250A				25
30A		300A									30
35A		350A									35
40A	40A	400A			40A		400A	400A			40
45A	45A		450A								45
50A	50A		500A								50
60A	60A		600A	600A				600A	600A		60
70A	70A			700A							70
80A	80A			800A					800A		80
90A	90A										90
100A	100A				100A	100A				1000A	10
110A	110A										11
125A	125A										12
	150A				150A						15
	175A										17

Interrupting Capacity @ 480V		
3VA4/3VA5	3VA6	
MCP/MCS	200K	0
MCP/MCS	MCP/MCS	1
25K		4
35K	35K	5
65K	65K	6
100K	100K	7
	150K	8

Trip Unit Protection Functions (see next page for details)

Number of Poles (see next page for details)

Connection Technology (see next page for details)

Regional Specifics (as applicable) (see next page for details)

Auxiliary Releases (see next page for details)

Auxiliary/Alarm Switches (see next page for details)

Catalog Numbering Logic (cont.)



(see previous page for details)

Trip Unit Protection Functions											
3VA4/3VA5		L	I	N							
TM230	MCCB	fix	adj								EC
TM210	MCCB	fix	fix								ED
TM240	MCCB	adj	adj								EF
TM230	MCCB	fix	adj	100%							GC
TM210	MCCB	fix	fix	100%							GD
TM240	MCCB	adj	adj	100%							GF
TM110M	MSP		fix								MG
TM120M	MSP		adj								MH
TM120M	MSP		adj								MU
MCS110	MSC		fix								BB
3VA6		L	S	I	G	N	LCD	com.	measurement values		
ETU320 LI	MCCB	adj		adj		0%/50%/100%					HL
ETU330 LIG	MCCB	adj		adj	adj	0%/50%/100%					HM
ETU350 LSI	MCCB	adj	adj	fix		0%/50%/100%					HN
ETU550 LSI	MCCB	adj	adj	adj		20/40%...100/160%	yes	yes	standard		JP
ETU556 LSI(G)	MCCB	adj	adj	adj	alarm	20/40%...100/160%	yes	yes	standard		JT
ETU560 LSIG	MCCB	adj	adj	adj	adj	20/40%...100/160%	yes	yes	standard		JQ
ETU820 LI	MCCB	adj		adj		20/40%...100/160%	yes	yes	advanced		KL
ETU830 LIG	MCCB	adj		adj	adj	20/40%...100/160%	yes	yes	advanced		KM
ETU850LSI	MCCB	adj	adj	adj		20/40%...100/160%	yes	yes	advanced		KP
ETU856 LSI(G)	MCCB	adj	adj	adj	alarm	20/40%...100/160%	yes	yes	advanced		KT
ETU860 LSIG	MCCB	adj	adj	adj	adj	20/40%...100/160%	yes	yes	advanced		KQ
ETU310M	MCP			adj							MS
MCS110	MCS			fix							BB

Number of Poles	
1 pole	1
2 pole	2
3 pole	3
4 pole	4
1-in-2 pole	5
2-in-3 pole	6

Connection Technology	
No wire connector	1
Nut keeper kit, line and load	2
Nut keeper kit, load end only	3
Aluminum wire connector, load end only	4
Wire connector, line end only	5
Wire connector, line and load	6

Regional Specifics (as applicable)	
Standard	0
NAVAL/50C	1
100% Rated (3VA6)	2

Auxiliary Releases	
Without	A

Auxiliary/Alarm Switches	
Without	A0