



Foot switch with metal enclosure

GFS 1Ö/1S RE

Article no.: 1048587 (old article no.: 81201601)

Product features

- With latching: ON/OFF principle
- Metal enclosure
- With protective shield
- High level of stability
- Low pedal height
- Wiring compartment

Dimensions

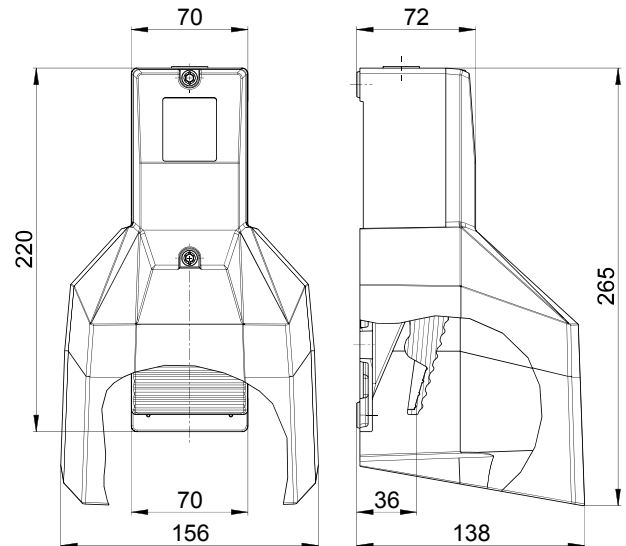

Technical data

Applied standards
EN 60947-5-1

Enclosure
aluminium die-cast, powder-coated

Pedal
thermoplastic, glass-fibre reinforced, shockproof, self-extinguishing UL 94 V-0

Protective shield
aluminium die-cast, powder-coated

Degree of protection
IP65 (IEC/EN 60529)

Connection
screw connection terminals

Cable cross-section
max. 2.5 mm² (incl. conductor ferrules)

Cable entry
1 x M20 x 1.5

Contact material
silver

Switching system
slow action, positive break NC contacts ⊖

Switch insert
1 x ES 60 GF RE

Switching elements
1 NC/1 NO contact with latching

Utilisation category
AC-15

Rated operating current/voltage I_e/U_e
16 A/400 VAC

Short-circuit protection
16 A gG/gN fuse

Ambient temperature
-25 °C ... +80 °C

Mechanical life
> 1 million operations

Approvals
c SP_{US} CCC

Weight
1280 g

Errors and omissions excepted.



Foot switch with metal enclosure

GFS 1Ö/1S RE

Article no.: 1048587 (old article no.: 81201601)

Contact diagram

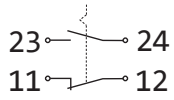

Switching diagram

