

FEATURES & BENEFITS

CONSTRUCTION

1-1/4" IPS Schedule 40 hot-dipped galvanized steel pipe and fittings along with powder-coated cast-iron 9" (22.9 cm) diameter floor flange provide corrosion resistance in a long lasting product.

SHOWERHEAD

AXION® MSR ABS plastic drench showerhead uses a hydrodynamic design to give equal distribution of water throughout the entire footprint of flow.

FLOW CONTROLS

Green ABS designed plastic showerhead and AXION® MSR eye/face wash head equipped with integral 20 gpm (75.7 L) flow shower control and built in 3.7 gpm (14.01 L) eye/face wash flow control to allow both parts of the emergency equipment to be safely used simultaneously. Flow controls provide the optimal water flow for an ideal coverage area.

FREEZE-PROOF VALVES

Self-draining eyewash and shower valves are designed to make the flushing of fluid remains occur with the simple push of either of the individual push plates. Special self-draining feature prevents the unit from freezing.

PUSH PLATES

Large 11 gauge zinc-plated push plates with graphics are clearly labeled on how to operate the equipment so no time is wasted when an emergency arises.

OPTIONS

- Test Tag: SP170 is a green waterproof test card with space for date and initials of inspector. Used to record weekly testing of emergency equipment.
- AXION® MSR Showerhead: Model SP829SS, AXION® MSR stainless steel drench showerhead with integral 20 gpm (75.7 L) flow control.
- Three Sided Safety Sign: Model 9020 green and yellow ABS plastic 3-sided high visibility sign.
- ANSI Shower and Eyewash Testing Kit: Model 9011 ANSI compliance test kit.

For more information, visit www.hawsc.com or call (888) 640-4297.



SPECIFICATIONS

Model 8300FP freeze protected combination shower and eyewash shall include an AXION MSR® showerhead with integral self-regulating 20 gpm flow control, stainless steel 11" (27.9 cm) round bowl, stainless steel eyewash yoke assembly with AXION® MSR eye/face wash head and dust cover, two self-draining bury valves with available frost-line depths of 24" and 42" (61 and 106.7 cm). All unused water drains out of the unit through drain valves in the ground below the frost line. Also included are two large 11 gauge zinc-plated steel push plates with universal graphics, powder-coated cast-iron 9" (22.9 cm) diameter floor flange, universal sign, 3/4" NPT and 1-1/4" NPT inlet, and 1-1/4" NPT outlet.

REQUIRES MODEL MK8A & MK81A PRICED SEPARATELY.

APPLICATIONS

Where the eyes or body of any person may be exposed to injurious or corrosive materials, suitable facilities for quick drenching or flushing of the eyes and body shall be provided within the work area for immediate emergency use. Emergency eyewash facilities and deluge showers shall be in unobstructed and accessible locations that require no more than 10 seconds for the injured person to reach. Model 8300FP is certified by CSA to meet the ANSI/ISEA Z358.1 Standard for Emergency Eyewash and Shower Equipment.



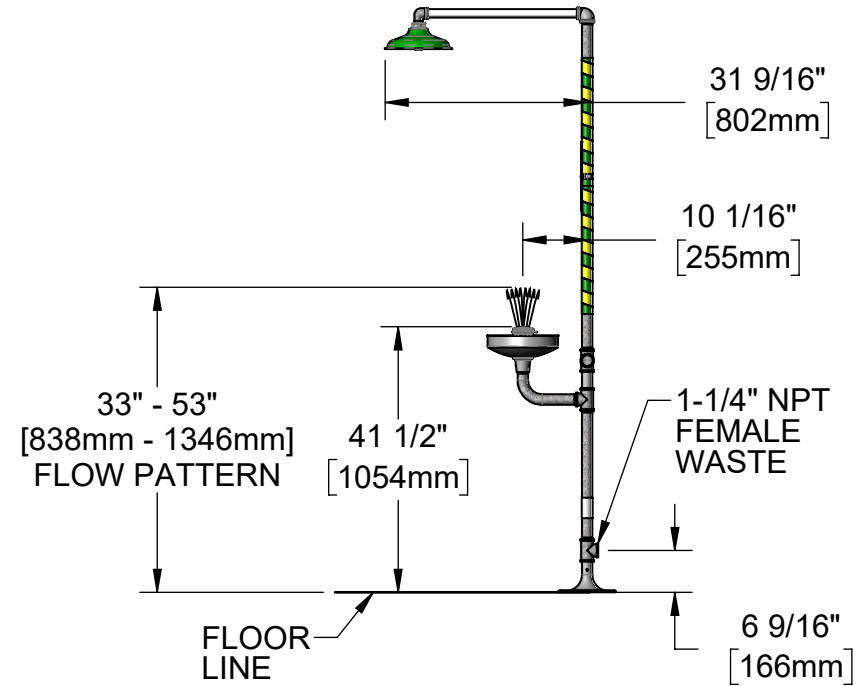
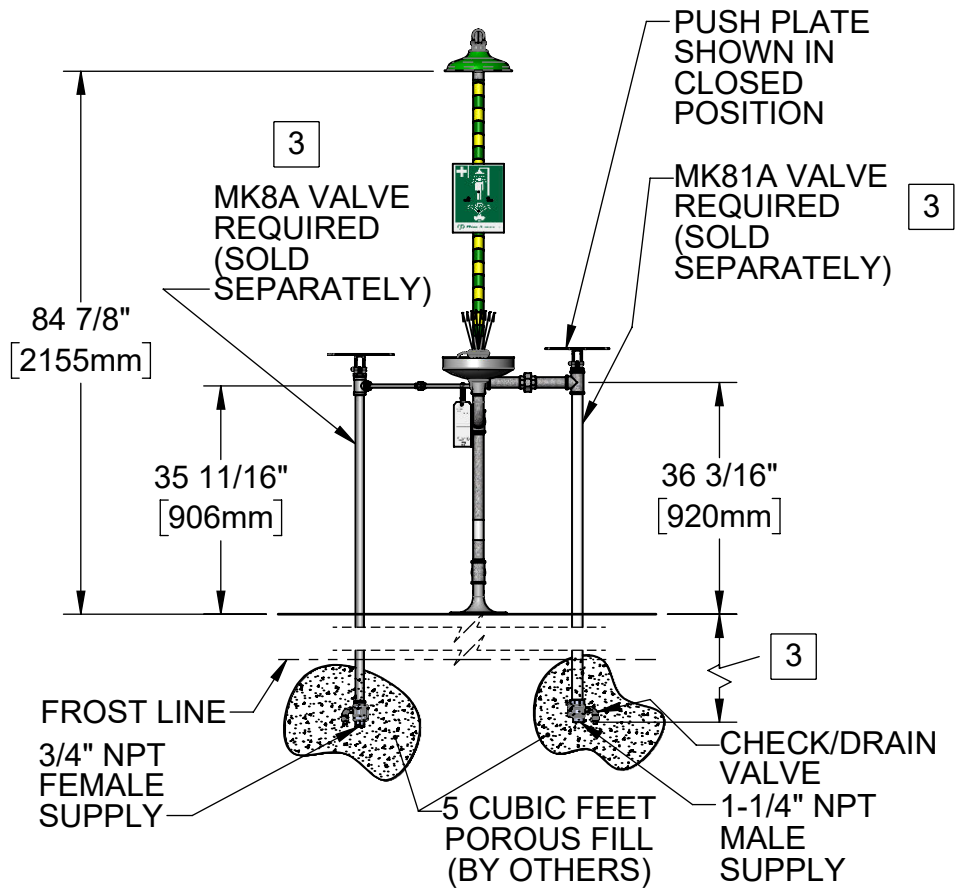

NOTES:

1. WHEN INSTALLING THIS UNIT, LOCAL, STATE, OR FEDERAL CODES SHOULD BE ADHERED TO. INSTALL A TRAP IN THE WASTE LINE AND A SCREWDRIVER STOP IN THE SUPPLY LINE IF REQUIRED.
2. TO COMPLY WITH ANSI Z358.1-2014 FOR EMERGENCY EYEWASH AND SHOWER EQUIPMENT:
 - UNIT SHALL BE INSTALLED IN ACCORDANCE WITH MANUFACTURER'S INSTRUCTIONS AND ACCEPTABLE PLUMBING PRACTICES.
 - EYEWASH STREAMS SHALL BE POSITIONED SUCH THAT STREAMS ARE 15.3 CM (6 IN.) MINIMUM FROM THE WALL OR NEAREST OBSTRUCTION AND, WHEN FLOWING AT 30-30.5 PSI, MEET ANSI GAUGE REQUIREMENTS BETWEEN 83.8 & 134.6 CM (33-53 IN) ABOVE FLOOR.
 - SHOWER SHALL BE POSITIONED SUCH THAT SHOWERHEAD IS BETWEEN 208.3 & 243.8 CM (82-96 IN.) FROM FLOOR.
 - SHOWER SPRAY PATTERN SHALL HAVE A MINIMUM DIAMETER OF 50.8 CM (20 IN.) AT 152.4 CM (60 IN.) ABOVE SURFACE ON WHICH USER STANDS, AND CENTER OF SPRAY PATTERN SHALL BE LOCATED AT LEAST 40.6 CM (16 IN.) FROM ANY OBSTRUCTION.
3. SPECIFY BURY DEPTH FOR FREEZE RESISTANT VALVE, STANDARD BURY DEPTHS ARE:
 - 24" [610mm] OR 42" [1067mm].
4. HOLD ROUGH-IN DIMENSIONS ±1/2" (12.7mm).

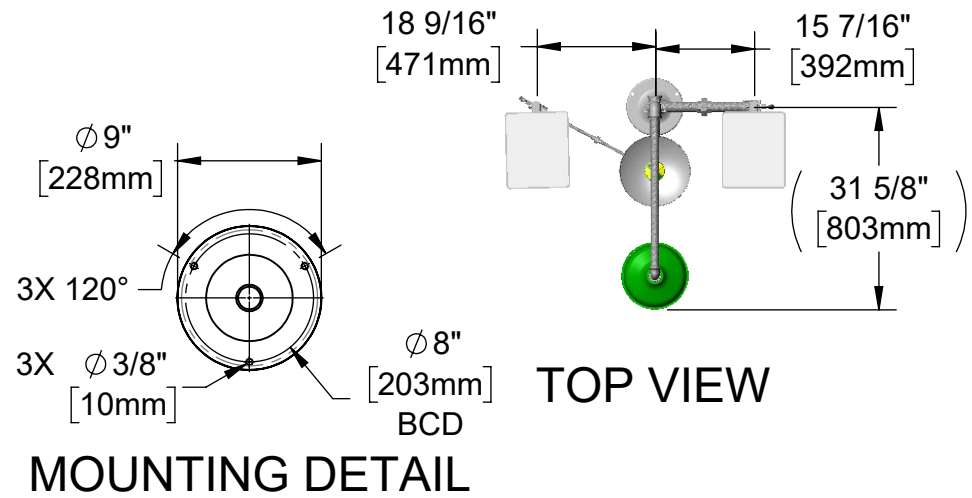

		1455 KLEPPE LANE SPARKS, NEVADA 89431 (775) 359-4712 FAX (775) 359-7424 E-MAIL: HAWS@HAWS.CO.COM WEBSITE: WWW.HAWS.CO.COM		
ECN: 1499	REV. ECN: 6264	BY: JU	MODEL(S): 8300FP	PART NUMBER: 0002080163.D
DRAWN: JU	DATE: 05/01/25	CHKD: DN		REVISION: 18
APPROVED: JU	DATE: 12/19/25	SCALE: 1:30	DRAWING TYPE: INSTALLATION	SHEET 1 OF 1