

SQUARE D

Instruction Bulletin

Bulletin No. 30072-005-105A

October, 1992

Raleigh, NC, U.S.A.

Supersedes 30072-005-105 Dated 6/92

3-Pole AC Vacuum Contactors

Type WG, Series A

Class 8502 and 8702 — NEMA Size 5

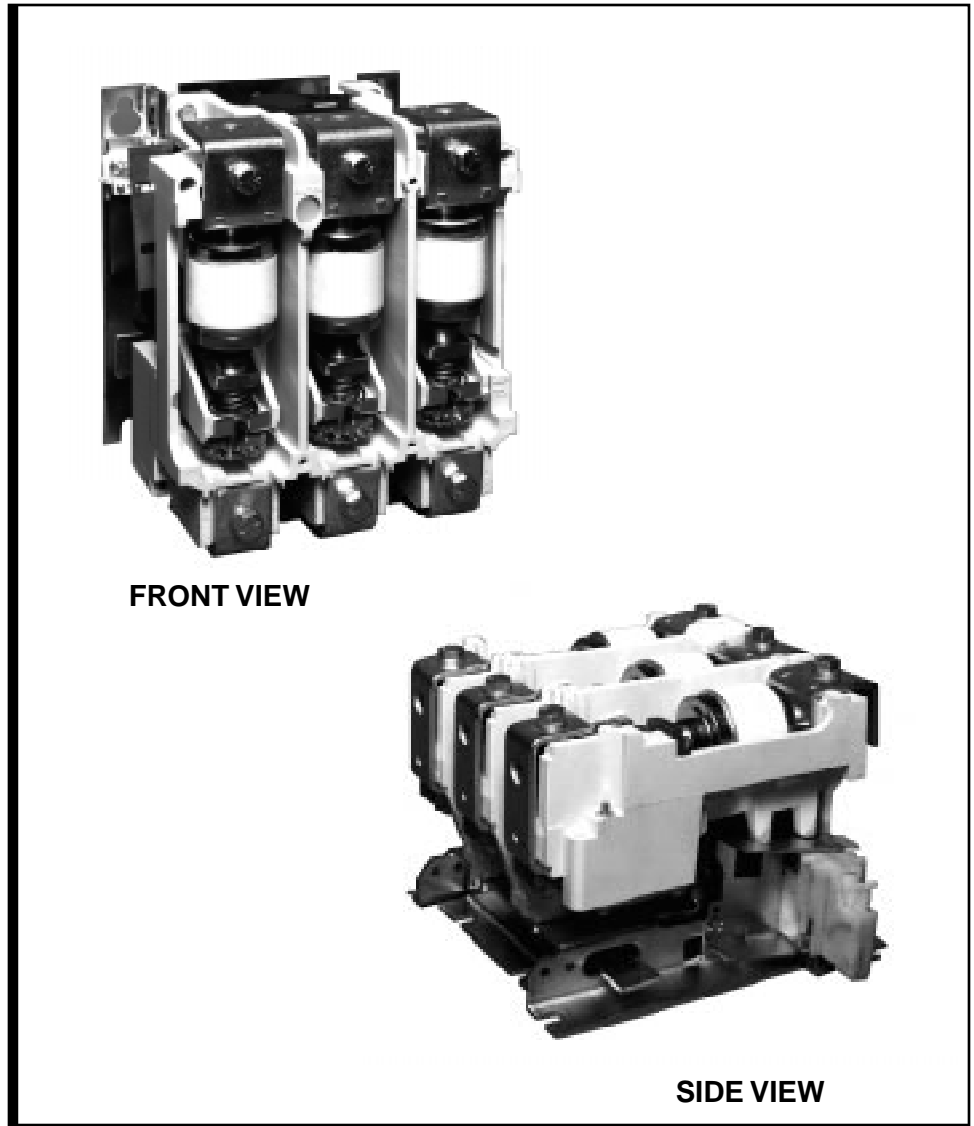

Three-Pole AC Vacuum Contactors

INTRODUCTION 1
MOUNTING..... 1
TERMINALS..... 1
PRINCIPLE OF OPERATION 2
AUXILIARY CONTACTS..... 2
INSTALLATION INSPECTION..... 3
 Insulation Level Check 3
 Vacuum Interrupter Check 3
CONTACT WEAR 4
INSPECTION AFTER SHORT CIRCUIT 5
COIL REPLACEMENT 5
COIL AUXILIARY CONTACT ADJUSTMENT 7
TIGHTENING TORQUES 7
SHORT-CIRCUIT PROTECTION..... 7
CONTROL WIRING..... 8

List of Figures

Figure 1 Size 5 Vacuum Contactor, Class 8502 Type WGO..... 5
Figure 2 Connection Diagram, Class 8502 Type WGO 8
Figure 3 Connection Diagram, Class 8702 Type WGO 9
Figure 4 Dimensional Drawing (Inches), Class 8502/8702 Type WGO 9

List of Tables

Table 1 Minimum Clearances — 600 V Maximum 1
Table 2 Auxiliary Contacts 2
Table 3 Replacement Coil Kits 5
Table 4 Recommended Driving Torque 7
Table 5 Maximum Ampere Ratings 7

INTRODUCTION

This instruction bulletin illustrates and describes Class 8502 and Class 8702 three-pole vacuum contactors. It also contains assembly, modification and parts ordering instructions. This NEMA Size 5 vacuum contactor is designed for the control of inductive or non-inductive loads at voltages between 200 and 600 VAC.

DANGER

HAZARDOUS VOLTAGE.

Disconnect all power before working on equipment.

Electrical shock will cause severe injury or death.

MOUNTING

Mount contactor with four 5/16" - 18 or four 1/4" - 20 bolts.

The contactor is intended to be mounted with its mounting plate vertical and the moving stem of the vacuum bottles aimed down. However, mounting position is not critical.

The vacuum contactor is designed to tolerate normal variations in barometric pressure up to an altitude of 6600 feet. If the contactor is to be used at higher elevations, please consult the local Square D sales office.

TERMINALS

Class 8502/8702 Type WGO contactors are supplied without power terminal lugs. A Class 9999 Type LUW5 power terminal lug kit is recommended and will accept one #0 - 500 kcmil wire per connection. The kit contains six lugs and mounting screws. **Use copper wire only**, 75°C minimum rating, on device power and control terminals. Regardless of the termination means used, maintain the minimum clearances listed in Table 1.

Table 1 Minimum Clearances — 600 V Maximum

Minimum clearance between any uninsulated live part and an uninsulated live part of opposite polarity, an uninsulated grounded part other than the enclosure, or exposed metal part.	Through Air	0.375"
Minimum clearance between any uninsulated live part and the metal enclosure.	Over Surface	0.500"
	Shortest Distance	0.500"

PRINCIPLE OF OPERATION

The Class 8502 Type WGO vacuum contactor has its main contacts sealed inside ceramic tubes (vacuum interrupters or bottles) in which a vacuum exists. No arc boxes are required because the vacuum has no ionized air to sustain the arc. The arc stops when the alternating current passes through zero at line frequency. The arc usually does not survive beyond the first half cycle after the contacts begin to separate. The metal bellows allow the contacts to open and close without letting air into the vacuum chamber.

The contacts in an unmounted bottle are normally-closed because the outside air pressure pushes against the flexible bellows. To keep the contacts in the normally-open position, a kickout spring is employed and is located in the rear of the contactor. The kickout spring pushes against the moving crossbar, which in turn pulls the contacts open.

The contactor coil consists of two separate coil windings, a pickup winding and a holding winding, encapsulated in a common coil assembly. The coil accepts AC control power connected directly to the coil terminals A and B as shown in Figure 2 on page 8. However, the coil assembly uses a full wave rectifier to furnish the DC power required by the coil winding. A normally-closed coil auxiliary contact (Class 9999 Type WLX01), set to open slightly before the armature fully closes, is connected to terminals C and D. This contact is adjusted to allow a relatively high current through the pickup winding and as the contactor closes, the contact inserts the holding winding, thereby reducing the coil current required to sufficiently hold the magnet closed without overheating.

AUXILIARY CONTACTS

Each Size 5 vacuum contactor is supplied with two mounting brackets for the addition of auxiliary contacts. The auxiliary contacts must be ordered separately; refer to Table 2. A normally-open auxiliary contact may be used as a holding circuit contact.

On a reversing Size 5 vacuum contactor, one Class 9999 Type WX11 auxiliary contact is supplied on both the forward and reverse contactor to provide electrical interlocking between the contactors and to provide the holding circuit contact.

A maximum of four additional auxiliary contact units may be installed on each non-reversing contactor and one additional auxiliary unit may be installed on each contactor (forward or reverse) of a reversing contactor. The auxiliary units mount by means of a spring clip and retaining screw. To remove the auxiliary unit, loosen the retainer screw and slide the auxiliary contact unit out of the recess.

For installation of auxiliary contact units refer to Instruction Bulletin 30072-005-107, supplied with each kit.

Table 2 Auxiliary Contacts

Contact Type	Class 9999	
1 Normally-Open and 1 Normally-Closed	WX11	
Ratings (NEMA A600, R300)		
Voltage	Make	Break
120-600 VAC	7200 VA	720 VA
72-120 VAC	60 A	720 VA
28-72 VAC	60 A	10 A
28-300 VDC	28 VA	28 VA

**INSTALLATION
INSPECTION****WARNING****HAZARDOUS VOLTAGE.**

Disconnect all power before conducting Insulation Level Check and Vacuum Interrupter Check.

Electrical shock can cause injury or death.

Before energizing the contactor for the first time and on a continuing basis, the contactor should be inspected by qualified electrical personnel. See the following sections for Insulation Level Check and Vacuum Interrupter Check.

**Insulation Level
Check**

After installation and before energizing the contactor for the first time, it is recommended that the insulation resistance between poles and from each pole to ground be measured and recorded. The reading will be dependent on other connected equipment and conditions of service. Any unusually low reading or sudden reduction in this reading after the contactor has been in service indicates a possible source of trouble, and the cause should be determined and corrected before restoring power.

**Vacuum Interrupter
Check****CAUTION****POSSIBILITY OF X-RAY EXPOSURE AT VOLTAGES ABOVE 5000.**

During dielectric test, stay at least ten feet away from contactor, preferably behind a metal barrier.

Exposure to x-rays can cause injury. This precaution must be observed until this possible hazard is better identified and standards are published.

The dielectric strength of each vacuum interrupter should be checked. A good interrupter will withstand a 5.5 kV, 50 or 60 Hz test across a 0.090 inch contact gap, which is the normal new gap.

It is unlikely, but possible to have some loss of vacuum which might seriously damage the ability of the bottle to interrupt the circuit. This condition may go unnoticed in a three-phase, ungrounded circuit, since it is possible for any two good interrupters to successfully interrupt the circuit. To guard against this condition, periodic dielectric tests across open contacts are desirable. The interval between periodic tests depends on the number of operations per day, environmental factors and experience.

CONTACT WEAR



HAZARDOUS VOLTAGE.

Disconnect all power before beginning the contact wear measurement procedure.

Read the instructions below carefully before attempting to measure contact wear.

Failure to observe these precautions can cause electrical shock and unexpected energization of load, resulting in injury or death.

When the contactor is fully closed, there is a gap between the pivot plate and the bottle stem as shown in Figure 1 on page 5. This gap is a measurement of the contact overtravel and is equivalent to the contact wear allowance provided on a new contactor. During the life of the contactor, contact material continually vaporizes from the contact faces and condenses inside the bottle, reducing the overtravel. Periodic measurement of this overtravel provides an indication of contact wear. **Do not re-adjust bottle position, which is set at the factory.**

Use the following procedure to measure contact wear:

1. Disconnect all power. Test to make sure there is no voltage present at the main power terminals or at the coil terminals. Coil terminal location is shown in Figure 4 on page 9.
2. Trace the wires connected to the coil terminals A (upper left) and B (upper right) to determine the source of coil power. If power to the coil is supplied from a source that is separate from the main power circuit, proceed to step 3 below. If power to the coil is supplied from the main power circuit, either directly or through a control transformer, remove all wiring from the coil terminals A (upper left) and B (upper right). **Do not** remove wiring from coil terminal C (lower left) or D (lower right). Now connect coil terminals A and B to a separate source of AC voltage that matches the rating marked on the coil.
3. Apply coil power to energize the contactor.
4. **NOTE: Be aware that the coil terminals are now energized. Keep body parts and tools away from the coil terminals to avoid danger of electrical shock.**
5. Use the 0.020" thick fork-shaped overtravel gauge supplied to measure the gap between the pivot plate and the bottle stem as shown in Figure 1 on page 5. If the gap is more than 0.020" on all bottles, the contacts are suitable for further use. If the overtravel gauge will not fit into the gap on any bottle, the contactor must be replaced.
6. Remove power to the coil. Reconnect, if necessary, to original circuit configuration.

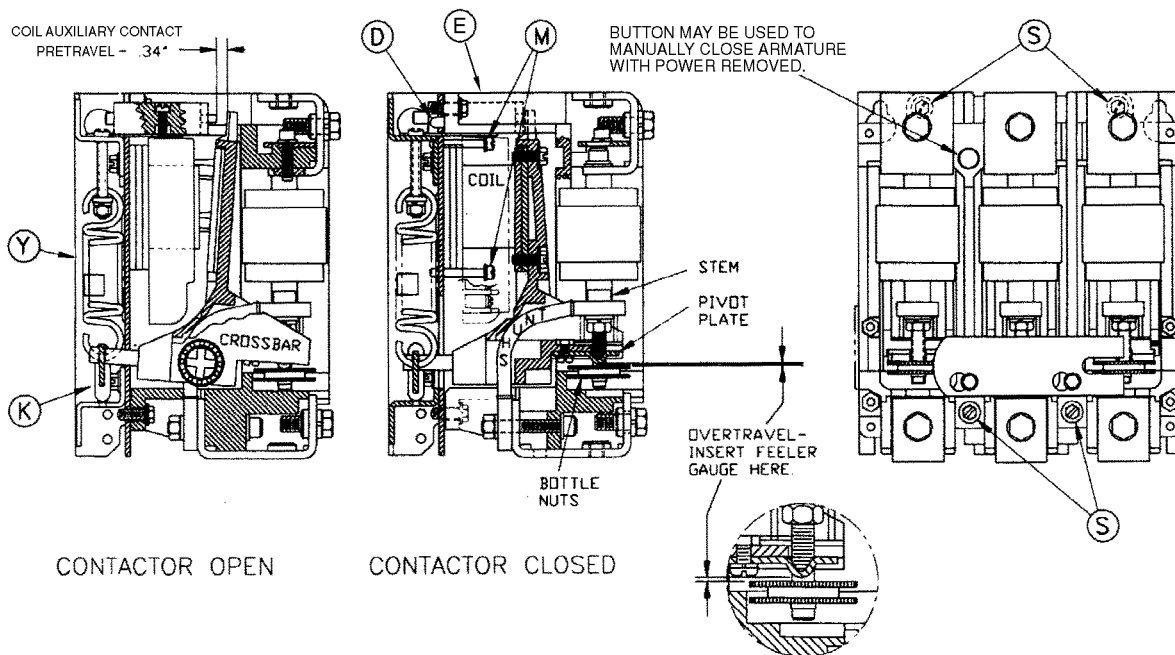

Figure 1 Size 5 Vacuum Contactor, Class 8502 Type WGO

INSPECTION AFTER SHORT CIRCUIT

Class 8502/8702 Type WGO vacuum contactors must be protected against overcurrent in accordance with applicable electrical codes and the maximum device ratings listed in Table 5 on page 7. However, the magnitude of a short circuit may exceed the damage threshold of the vacuum bottles. After a short circuit, the effects of physical stress on the contactor should be checked along with the overtravel, dielectric strength and insulation level. Physical damage or deformation of conductor bars and cables would indicate severe stress. The overtravel should not have changed significantly and should still exceed the 0.020 inch minimum. Refer to CONTACT WEAR on page 4. The insulation level check and vacuum interrupter check described on page 3 must be conducted. If there is no evidence of physical stress and if overtravel, dielectric strength and insulation level are satisfactory, the contactor may be returned to service. Otherwise replace the unit.

COIL REPLACEMENT

The coil has a pickup winding that is intermittently rated. If the Class 9999 Type WLX01 auxiliary contact does not open properly it is possible that the coil may burn out in a matter of minutes. Refer to COIL AUXILIARY CONTACT ADJUSTMENT on page 7.

Table 3 Replacement Coil Kits

Voltage (AC)	Frequency (Hz)	Class/Type
120/110	60/50	9998WG120
240/220	60/50	9998WG240
480/440	60/50	9998WG480
600/550	60/50	9998WG600



HAZARDOUS VOLTAGE.

Disconnect all power before replacing coil.

Electrical shock will cause severe injury or death.

To replace the coil (Refer to Figure 1 on page 5 for item locations):

1. Disconnect all power from the contactor.
2. Disconnect the leads to the coil terminals. Note their position for reconnection in step 9.
3. Disconnect the line and load leads from the contactor power terminals.
4. Remove the four 1/4" - 20 screws (item S) that hold the frame subassembly (item E) to the baseplate (item Y).
5. Lift the line side of the frame subassembly away from the baseplate until two dowels (item D) are clear of their holes. The frame subassembly will automatically move under pressure from the kickout system until the kickout bar (item K) reaches the end of its slots in the baseplate. The frame subassembly is then free to be moved away from the coil.
6. The coil is now accessible. Remove the two mounting screws (item M) to free the coil.
7. Install the replacement coil and replace the two mounting screws (item M).
8. Place the frame subassembly onto the baseplate so that the two posts extending from the crossbar go through the oblong slots in the baseplate and into the notches in the kickout bar (item K). Push the frame subassembly along the surface of the baseplate toward the kickout bar until the dowels (item D) slip into the dowel holes. Replace the four mounting screws (item S) removed in Step 4. **Verify that the coil leads to the Class 9999 Type WLX01 auxiliary contact are not pinched under the frame feet.**
9. Reconnect coil leads. NOTE that coil control wires are attached to upper coil terminal A on the left side of the coil and upper coil terminal B on the right side of the coil, and the 9999WLX01 coil auxiliary contact leads are attached to lower coil terminal C on the left side and lower coil terminal D on the right side.
10. Recheck the coil auxiliary contact for proper adjustment. Refer to COIL AUXILIARY CONTACT ADJUSTMENT on page 7.
11. Manually verify that the kickout bar is seated on the posts from the crossbar.
12. Reconnect the line and load leads.
13. Tighten the assembly screws to the recommended driving torque listed in Table 4 on page 7.

COIL AUXILIARY CONTACT ADJUSTMENT

DANGER

HAZARDOUS VOLTAGE.

Disconnect all power before adjusting coil auxiliary contact.

Electrical shock will cause severe injury or death.

The nominal 0.34 inch pretravel gap shown in Figure 1 on page 5, (upper left corner) must be maintained on the normally-closed coil auxiliary contact for proper coil operation. If the pretravel gap is too large, the holding winding of the coil will not be inserted as the contactor closes, thereby causing the pickup winding to burn out due to the intermittent rating. If the pretravel gap is too small, the holding winding will be inserted too soon, thereby reducing the force to “hold” before the contactor is closed and causing the contactor to telegraph.

The Class 9999 Type WLX01 auxiliary contact can be adjusted by loosening the two slotted hexagonal washer head screws that secure the auxiliary contact mounting bracket, repositioning the bracket and tightening the auxiliary contact mounting bracket screws. The mounting bracket screws are accessible from the top side of the contactor.

TIGHTENING TORQUES

Factory recommended tightening torques are listed in Table 4. To ensure proper device operation, these tightening torques must be followed when installing, assembling or adjusting the device. Refer to Figure 1 on page 5 for item locations.

Table 4 Recommended Driving Torque

Item	Description	Driving Torque
Note 1	Coil Terminal Wire Connector (4)	7 - 9 lb-in.
M	Coil Mounting Screws (2)	10 - 15 lb-in.
S	Base Mounting Screws (4)	60 - 65 lb-in.

Note 1: Coil terminals A, B, C, and D shown in Figure 4 on page 9.

SHORT-CIRCUIT PROTECTION

Suitable for use on a circuit capable of delivering not more than 10,000 rms symmetrical amperes - 600 Volts maximum. Rating of branch-circuit protective device must comply with applicable electrical codes and the maximum protective device ratings listed in Table 5.

Table 5 Maximum Ampere Ratings

Maximum Voltage	Class K5, RK5 or RK1 Fuse*	Class J Fuse	Inverse-Time Circuit Breaker
600	400	600	400

* Time Delay fuse may be required

CONTROL WIRING

Control circuit conductors must be protected against overcurrent in accordance with applicable electrical codes. This may require installation of protective devices not shown in the control circuit connection diagrams. Fuse holder kits Class 9999SF4 and 9999SFR4 are available to allow compliance.

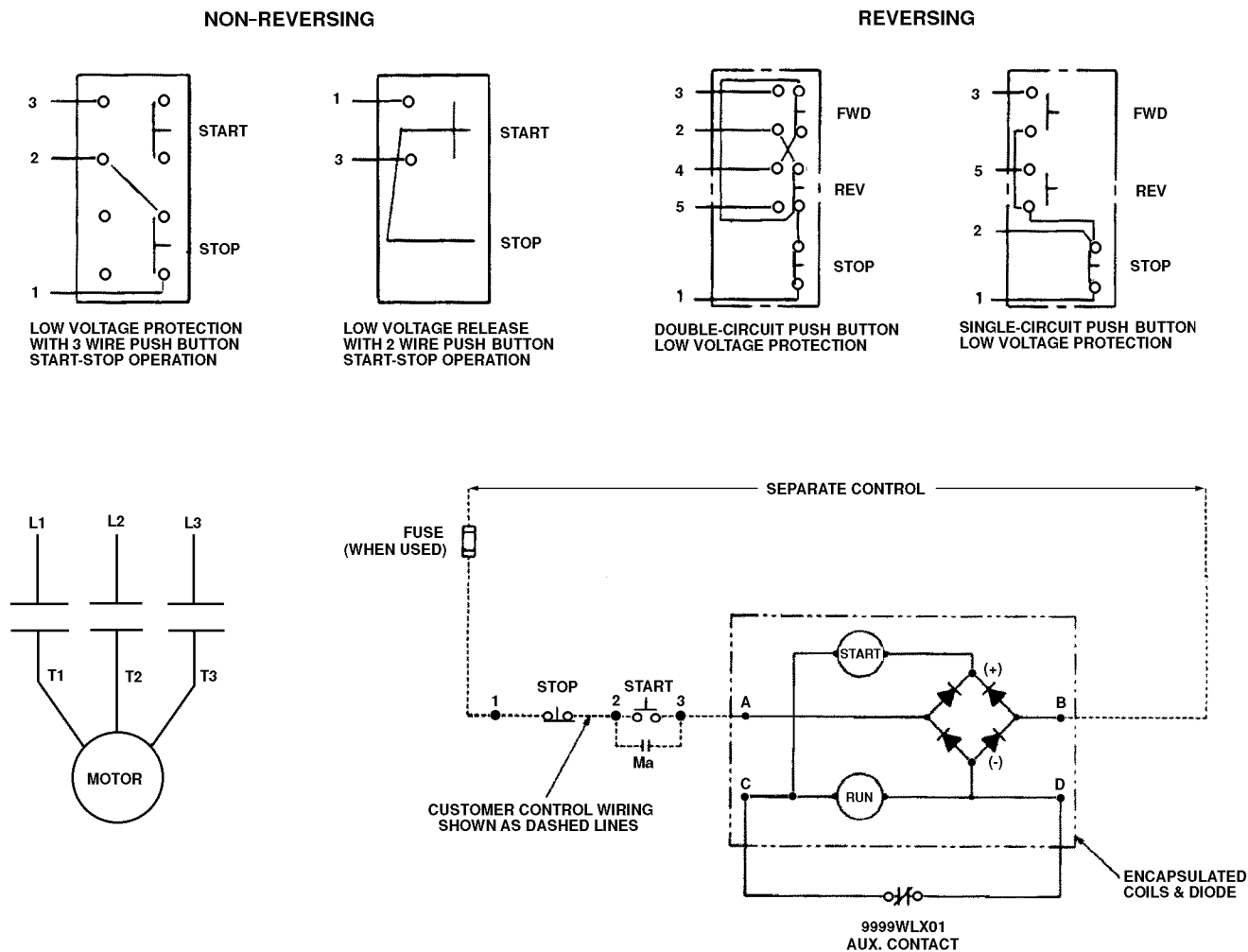

Figure 2 Connection Diagram, Class 8502 Type WGO

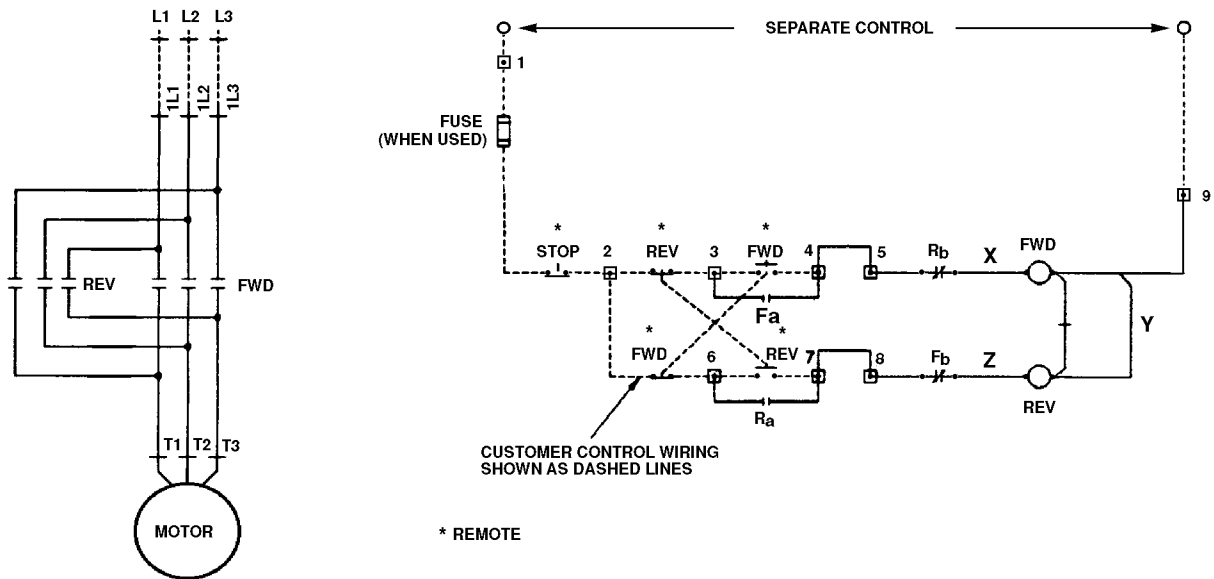

Figure 3 Connection Diagram, Class 8702 Type WGO

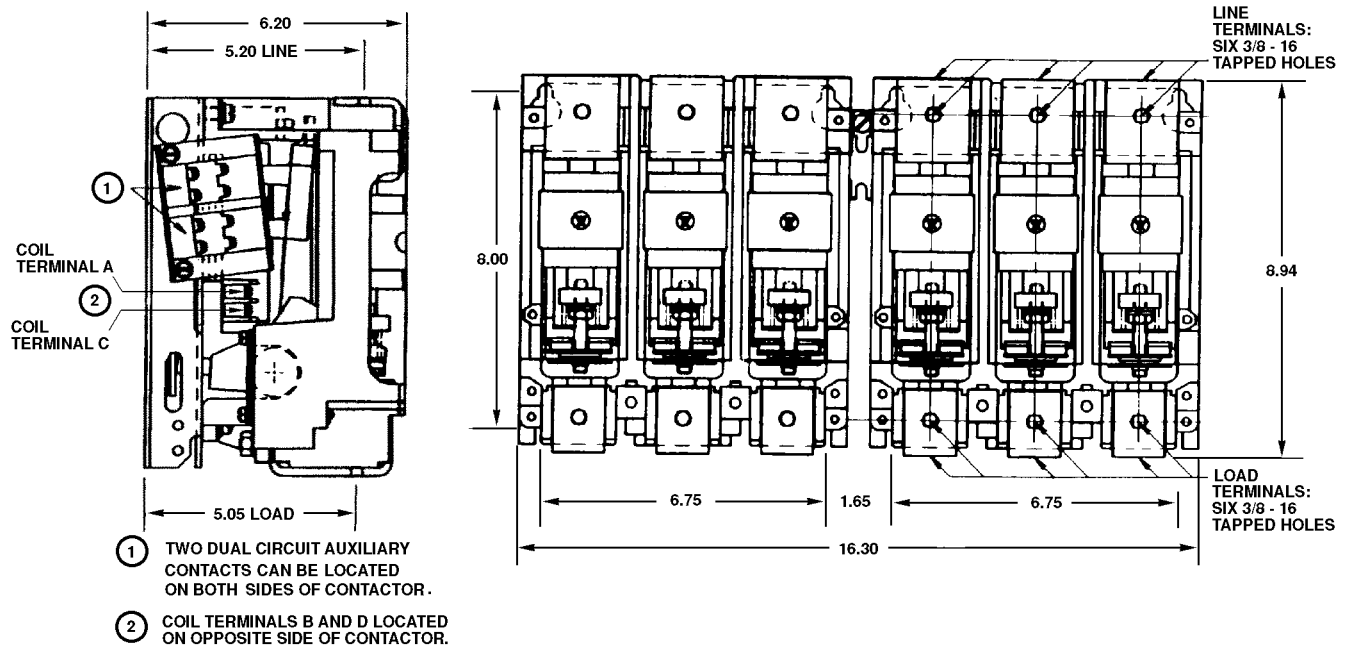

Figure 4 Dimensional Drawing (inches), Class 8502/8702 Type WGO



California Proposition 65 Warning—Lead and Lead Compounds

Advertencia de la Proposición 65 de California—Plomo y compuestos de plomo

Avertissement concernant la Proposition 65 de Californie—Plomb et composés de plomb

⚠ WARNING: This product can expose you to chemicals including lead and lead compounds, which are known to the State of California to cause cancer and birth defects or other reproductive harm. For more information go to: www.P65Warnings.ca.gov.

⚠ ADVERTENCIA: Este producto puede exponerle a químicos incluyendo plomo y compuestos de plomo, que es (son) conocido(s) por el Estado de California como causante(s) de cáncer y defectos de nacimiento u otros daños reproductivos. Para mayor información, visite : www.P65Warnings.ca.gov.

⚠ AVERTISSEMENT: Ce produit peut vous exposer à des agents chimiques, y compris plomb et composés de plomb, identifiés par l'État de Californie comme pouvant causer le cancer et des malformations congénitales ou autres troubles de l'appareil reproducteur. Pour de plus amples informations, prière de consulter: www.P65Warnings.ca.gov.

All trademarks are the property of Schneider Electric SE, its subsidiaries, and affiliated companies.

Schneider Electric USA, Inc.
800 Federal Street
Andover, MA 01810 USA
888-778-2733
www.schneider-electric.us

Todas las marcas comerciales son propiedad de Schneider Electric SE, sus filiales y compañías afiliadas.

Importado en México por:
Schneider Electric México, S.A. de C.V.
Av. Ejercito Nacional No. 904
Col. Palmas, Polanco 11560 México, D.F.
55-5804-5000
www.schneider-electric.com.mx

Toutes les marques commerciales sont la propriété de Schneider Electric SE, ses filiales et compagnies affiliées.

Schneider Electric Canada, Inc.
5985 McLaughlin Road
Mississauga, ON L5R 1B8 Canada
800-565-6699
www.schneider-electric.ca