

**MADERA™ FloWise® 15" HIGH 1.1 GPF  
FLUSHOMETER TOILET SYSTEM with EVERCLEAN®**

- ❑ **3451.511** 1.1 gpf 15" High Top Spud Bowl and Selectronic® Flush Valve

**BOWL:**

- Floor mount elongated flushometer valve toilet
- Vitreous china
- High Efficiency, Low Consumption. Operates in the range of 1.1 gpf to 1.6 gpf (4.2 Lpf to 6.0 Lpf)
- Permanent EverClean® surface inhibits the growth of stain- and odor-causing bacteria, mold, and mildew on the surface
- Fully glazed 2-1/8" trapway
- 10" or 12" roughing-in
- 15" rim height
- Condensation channel
- Powerful direct-fed siphon jet action
- 10" x 12" water surface area
- 1-1/2" inlet spud
- 100% factory flush tested
- Less toilet seat
- Model 3451.001

**SELECTRONIC® FLUSH VALVE:**

- Electronic flush valve with Selectronic® proximity system for "Hands Free" operation
- Self-Cleaning Piston with integral wiper spring helps prevent clogging and reduces maintenance
- Positive seal ensures leak-free performance
- Fully mechanical Manual Override Button can flush toilet during a power outage
- Range can be adjusted manually or by remote control
- Sensor & electronic controls are fully enclosed and water resistant
- Automatically flushes after 24 hours of non-use to maintain trap seal
- 3-second Flush Delay
- Battery life up to 4 years/approx. 200,000 cycles
- Low Battery indicator
- Battery can be changed without turning off the water
- Factory-installed 6V lithium battery included
- Adjustable tailpiece for rough-in flexibility
- Can be installed left or right hand
- Model 6065.111.002

**Includes:**

- 047007-0070A Inlet Spud (furnished with bowl)
- 481310-100 2 Bolt caps with retainers (furnished with bowl)
- 1" I.P.S. angle stop with back-flow prevention and vandal-resistant cap
- Sweat solder kit including cover tube and wall flange
- 1-1/2" vacuum breaker with adjustable tailpiece
- Spud coupling & flange



SEE REVERSE FOR ROUGHING-IN DIMENSIONS

**Ultra High-Efficiency Toilet System**

- 31% water savings when compared to 1.6 gpf toilet systems
- Extra 11% water savings when compared to 1.28 gpf toilet systems

**System MaP Score:**

- 800 grams of miso @ 1.1 gpf

**Operating Pressure:**

Overall Range: 20-125 psi\*\*  
Recommended: 25 psi (flowing)-80 psi (static)  
\*\* Water pressure over 80 psi is not recommended for most plumbing fixtures.

**Flow Requirement:**

25gpm (94.6 L/min.)

**Nominal Fixture Dimensions:**

718 x 356 x 381mm (28-1/4" x 14" x 15")

**To Be Specified:**

- ❑ Color: ❑ White
- ❑ Seat:
  - ❑ American Standard #5901.100 Heavy duty open front less cover
  - ❑ American Standard #5905.100 Extra heavy duty open front less cover

**EVERCLEAN®**  
Surface



# MADERA™ FloWise® 15" HIGH 1.1 GPF FLUSHOMETER TOILET SYSTEM

with EVERCLEAN®  
SELECTRONIC® FLUSH VALVE

## Fixture Compliance Certifications - Meets or Exceeds the Following Specifications:

- ASME A112.19.2-2008 / CSA B45.1-08 for Vitreous China Fixtures

## Valve Listings:

- ASSE 1037
- ANSI/ASME A112.19.2
- ADA Compliant

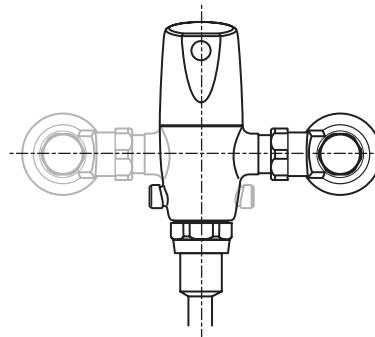
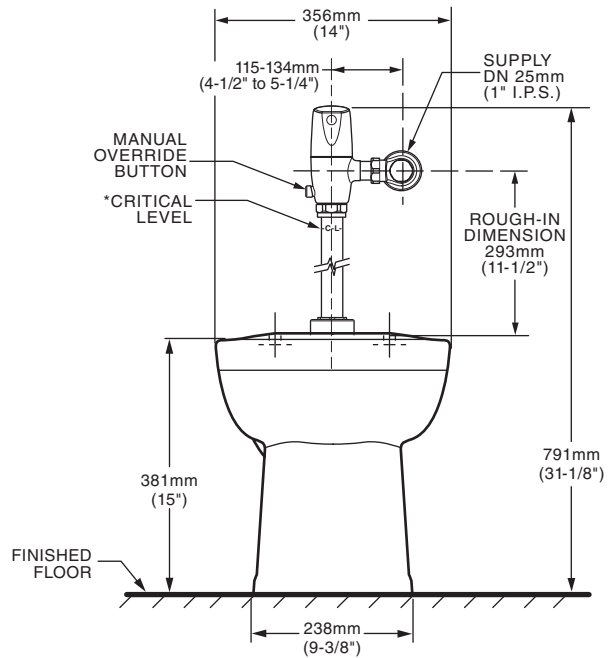
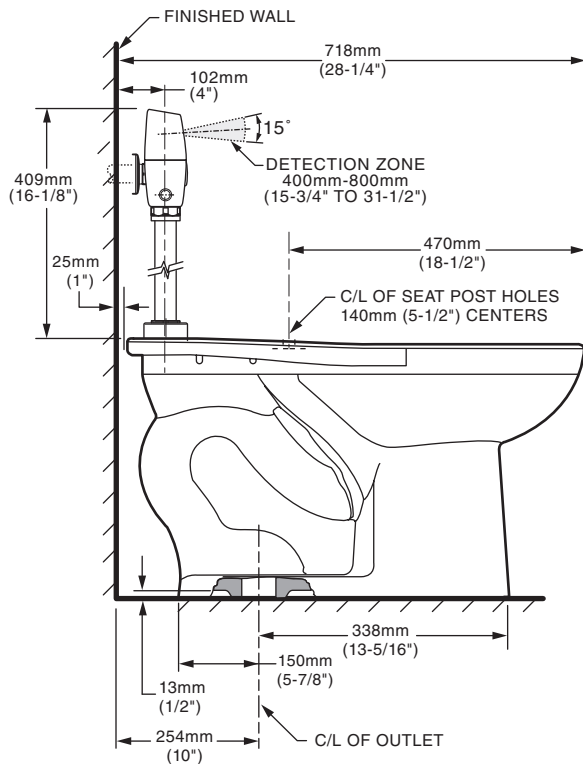

VALVE LEFT or RIGHT HAND INSTALLATION

\*Note: The Critical Line (-C-L-) on Vacuum Breaker must typically be a minimum of 6" (152mm) above fixture. Consult Codes for details.

### NOTES:

TO COMPLY WITH AREA CODE GOVERNING THE HEIGHT OF VACUUM BREAKER ON THE FLUSHOMETER VALVE, THE PLUMBER MUST VERIFY DIMENSIONS SHOWN FOR SUPPLY ROUGHING. THIS TOILET DESIGNED TO ROUGH-IN AT A MINIMUM DIMENSION OF 254MM (10") AND A MAXIMUM DIMENSION OF 305MM (12") FROM FINISHED WALL TO C/L OF OUTLET.

FLUSHMETER VALVE REQUIREMENTS FOR 12" (305MM) ROUGH-IN: SWEAT EXTENSION NIPPLE IS REQUIRED. REFER TO VALVE MANUFACTURER AND LOCAL CODES

**IMPORTANT:** Dimensions of fixtures are nominal and may vary within the range of tolerances established by ANSI Standard A112.19.2. These measurements are subject to change or cancellation. No responsibility is assumed for use of superseded or voided pages.