



**Vestil Manufacturing Corp.**  
 2999 North Wayne Street, P.O. Box 507, Angola, IN 46703  
 Telephone: (260) 665-7586 -or- Toll Free (800) 348-0868  
 Fax: (260) 665-1339  
 Web: [www.vestilmfg.com](http://www.vestilmfg.com) e-mail: [info@vestil.com](mailto:info@vestil.com)

# CB-S-2S



**Receiving instructions:**

After delivery, remove the packaging from the product. Inspect the product closely to determine whether it sustained damage during transport. If damage is discovered, record a complete description of it on the bill of lading. If the product is undamaged, discard the packaging.

**NOTE:**

The end-user is solely responsible for confirming that product design, use, and maintenance comply with laws, regulations, codes, and mandatory standards applied where the product is used.

**Replacement Parts and Technical Assistance:**

To order replacement parts, labels, and accessories, contact the technical service and parts department online at [http://www.vestilmfg.com/parts\\_info.htm](http://www.vestilmfg.com/parts_info.htm). Alternatively, you may request replacement parts and/or service by calling (260) 665-7586 and asking for the Parts Department.

**Table of Contents**

Signal Words.....	2
Safety Instructions.....	2
Exploded View and Bill of Materials.....	3
Inspections and Maintenance.....	4
Labeling Diagram.....	4
Limited Warranty.....	5

## SIGNAL WORDS

This manual uses SIGNAL WORDS to direct the reader's attention to important safety-related messages. These messages describe uses of the product that could result in personal injury or property damage. Each signal word corresponds to a specific hazard level. The following are definitions of signal words that might appear in this manual.



Identifies a hazardous situation which, if not avoided, **WILL** result in DEATH or SERIOUS INJURY. Use of this signal word is limited to the most extreme situations.



Identifies a hazardous situation which, if not avoided, **COULD** result in DEATH or SERIOUS INJURY.



Indicates a hazardous situation which, if not avoided, **COULD** result in MINOR or MODERATE injury.



Identifies practices likely to result in product/property damage, such as operation that might damage the product.

## SAFETY INSTRUCTIONS

Vestil strives to identify all foreseeable hazards associated with the use of its products. However, material handling is dangerous and no manual can address every conceivable risk. Ultimately, the most effective way to prevent injury is to apply sound judgment whenever using this device.



Improper or careless use of this product could result in death or serious personal injuries.

- **Read and understand the entire manual before assembling, installing, using or servicing the product.**
- Read the manual to refresh your understanding of proper use and maintenance procedures.
- DO NOT attempt to resolve any problem(s) with the product unless you are both authorized to do so and certain that it will be safe to use afterwards.
- DO NOT modify the product in any way UNLESS you first obtain written approval from Vestil. Unauthorized modifications automatically void the Limited Warranty and might make the product unsafe to use.
- DO NOT exceed the maximum rated load (see Label 287 on product).
- Inspect the product before each use.
  - A. DO NOT use this product if the inspection reveals structural damage. Examples of structural damage include, but are not limited to, the following: 1) Cracked, broken or significantly deformed load-bearing members; 2) cracked welds; 3) missing or deformed safety chain/strap; 3) corrosion, severe wear, or other condition that affects the ability of the product to support weight or itself. Replace each part that fails to pass an inspection, and DO NOT use the product until it is fully restored to normal condition.
  - B. DO NOT use the product if any unusual noise or movement is observed. If a malfunction occurs, remove the unit from service and notify your supervisor & maintenance personnel about the issue.
- DO NOT use this device UNLESS all product labels (see "Labeling Diagram") are readable and undamaged.
- Solidly anchor this cylinder rack to level, even concrete surface with anchor bolts selected by your building engineer. NOTE: 2-cylinder model CB-S-2S has 2 holes in the cylinder mount bracket assembly (item 5 in *Exploded View* on p.3) for attaching the unit to a wall with 3/8" lag screws or anchor bolts.
- Apply all occupational safety and health rules, building codes, local ordinances, etc. regarding the safe handling and storage of compressed gas cylinders.



Proper use, maintenance, and storage are essential for this product to function properly.

- Always use this product in accordance with the instructions in this manual and consistent with any training relevant to machines, devices, etc. used in conjunction with this product.
- Keep the product clean & dry.

## EXPLODED VIEW AND BILL OF MATERIALS

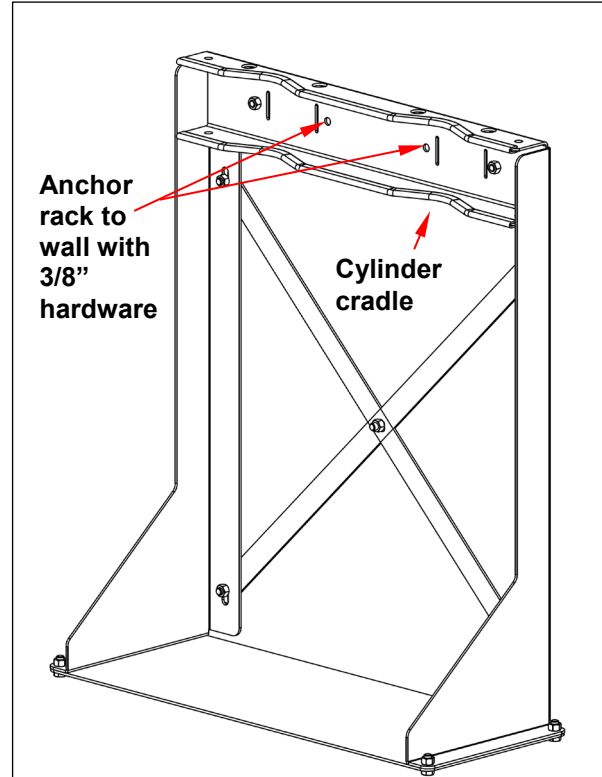
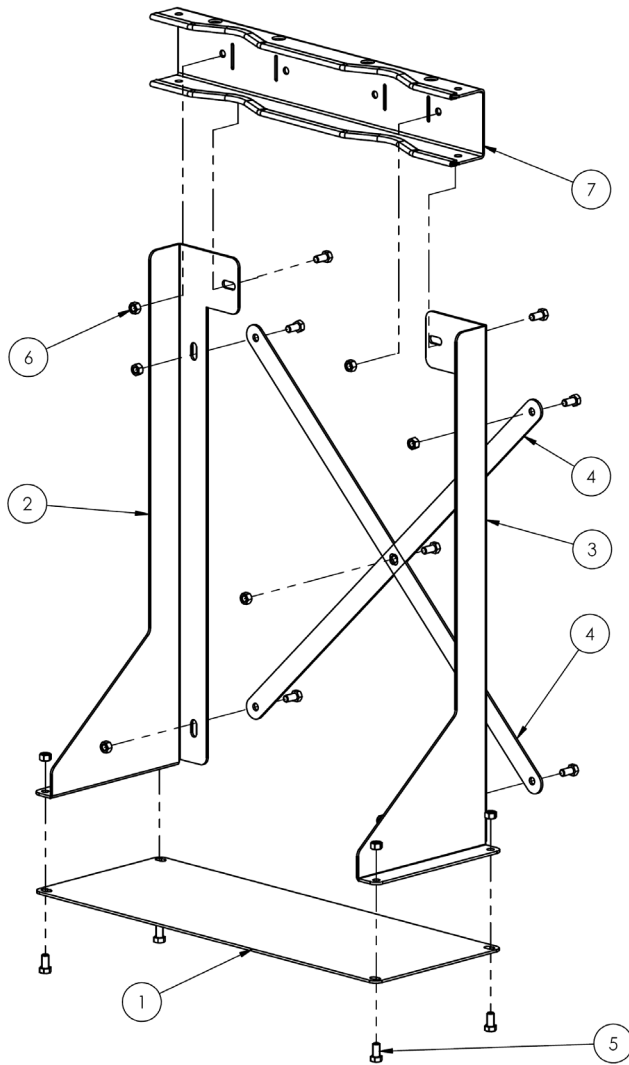

### ANCHORING THE RACK

Before loading the rack with cylinders, attach it to a wall with 3/8" anchoring hardware.

### USING THE RACK

Load the rack with, at most, 2 cylinders. Rest the cylinders against the cylinder cradles. Secure cylinders to the rack with the straps.

ITEM NO.	PART NO.	DESCRIPTION	QTY
1	16-014-320	BOTTOM DECK PLATE	1
2	16-014-321	LEFT SIDE PANEL FRAME	1
3	16-014-322	RIGHT SIDE PANEL FRAME	1
4	16-017-063	BAR STIFFENER	2
5	11103	HEX BOLT, GRADE A, ZINC PLATED, 3/8 X 16X3/4	11
6	36106	HEX NUT, GRADE A, ZINC PLATED, 3/8-16	11
7	16-001-216	CYLINDER MOUNT BRACKET ASSEMBLY	1

## INSPECTIONS AND MAINTENANCE

**Written record** — before using the product for the first time, make a written record of its appearance. Describe the condition of the frame, hardware, and mechanisms. Take photographs of each feature and add them to the record. Take photographs of all labels applied to the product. Describe where each label is located. ***This record establishes normal condition.***

When conducting the following inspections, compare your observations to the record to determine if a component is in normal condition. Do not use the product unless every component is in normal condition. Cosmetic changes, like damaged paint/powder coat do not constitute changes from normal condition. However, touchup paint should be applied to all affected areas as soon as damage occurs. Contact Technical Service (contact information appears on the cover page) to order replacement parts.

**Before each use** — perform the following inspections.

1. Check the surface of the product for dirt or other matter. Clean the surfaces.
2. Examine hardware & fasteners, including but not limited to bolts, nuts, and pins. Replace damaged, worn, or corroded hardware.
3. Examine frame elements for excessive wear, breakages, corrosion/rusting, damage, and metal fatigue.
4. Check all labels (see “Labeling diagram” on p. 5). Replace labels that are damaged or not easily readable.
5. Examine the whole structure for severe rusting/metal erosion, rot, thinned regions. If rusting is purely superficial, remove the rust/corrosion with a steel bristle brush or steel wool. Clean the affected area and apply touchup paint. If rusting, rot, or thinning has weakened the material, contact technical service for advice.

## LABELING DIAGRAM

The unit should be labeled as shown in the diagram. However, label content and locations are subject to change so your product might not be labeled exactly as shown. Replace all labels that are damaged, missing, or not easily readable (e.g. faded). To order replacement labels, contact the technical service and parts department online at [http://www.vestilmfg.com/parts\\_info.htm](http://www.vestilmfg.com/parts_info.htm). Alternatively, you may request replacement parts and/or service by calling (260) 665-7586 and asking the operator to connect you to the Parts Department.

MODEL/MODÉLO/MODÈLE	_____
STATIC CAPACITY (evenly distributed)	_____ lbs.
LA CAPACIDAD CONSTANTE (distribuida uniformemente)	_____ kgs.
CAPACITÉ STATIQUE (distribuée régulièrement)	_____ kgs.
SERIAL/SERIE/SÉRIE	_____

287





## LIMITED WARRANTY

Vestil Manufacturing Corporation (“Vestil”) warrants this product to be free of defects in material and workmanship during the warranty period. Our warranty obligation is to provide a replacement for a defective, original part covered by the warranty after we receive a proper request from the Warrantee (you) for warranty service.

### Who may request service?

Only a warrantee may request service. You are a warrantee if you purchased the product from Vestil or from an authorized distributor AND Vestil has been fully paid.

### Definition of “original part”?

An original part is a part used to make the product as shipped to the Warrantee.

### What is a “proper request”?

A request for warranty service is proper if Vestil receives: 1) a photocopy of the Customer Invoice that displays the shipping date; AND 2) a written request for warranty service including your name and phone number. Send requests by one of the following methods:

<u>US Mail</u>	<u>Fax</u>	<u>Email</u>
Vestil Manufacturing Corporation 2999 North Wayne Street, PO Box 507 Angola, IN 46703	(260) 665-1339 <u>Phone</u> (260) 665-7586	<a href="mailto:info@vestil.com">info@vestil.com</a> Enter “Warranty service request” in subject field.

In the written request, list the parts believed to be defective and include the address where replacements should be delivered. After Vestil receives your request for warranty service, an authorized representative will contact you to determine whether your claim is covered by the warranty. Before providing warranty service, Vestil will require you to send the entire product, or just the defective part (or parts), to its facility in Angola, IN.

### What is covered under the warranty?

The warranty covers defects in the following original, dynamic parts: motors, hydraulic pumps, motor controllers, and cylinders. It also covers defects in original parts that wear under normal usage conditions (“wearing parts”), such as bearings, hoses, wheels, seals, brushes, and batteries.

### How long is the warranty period?

The warranty period for original dynamic components is 30 days. For wearing parts, the warranty period is 90 days. Both warranty periods begin on the date Vestil ships the product to the Warrantee. If the product was purchased from an authorized distributor, the periods begin when the distributor ships the product. Vestil may, at its sole discretion, extend a warranty period for products shipped from authorized distributors by up to 30 days to account for shipping time.

### If a defective part is covered by the warranty, what will Vestil do to correct the problem?

Vestil will provide an appropriate replacement for any *covered* part. An authorized representative of Vestil will contact you to discuss your claim.

### What is not covered by the warranty?

The Warrantee (you) are responsible for paying labor costs and freight costs to return the product to Vestil for warranty service.

### Events that automatically void this Limited Warranty.

- Misuse;
- Negligent assembly, installation, operation or repair;
- Installation/use in corrosive environments;
- Inadequate or improper maintenance;
- Damage sustained during shipping;
- Collisions or other accidents that damage the product;
- Unauthorized modifications: Do not modify the product IN ANY WAY without first receiving written authorization from Vestil.

### Do any other warranties apply to the product?

Vestil Manufacturing Corp. makes no other express warranties. All implied warranties are disclaimed to the extent allowed by law. Any implied warranty not disclaimed is limited in scope to the terms of this Limited Warranty. Vestil makes no warranty or representation that this product complies with any state or local design, performance, or safety code or standard. Noncompliance with any such code or standard is not a defect in material or workmanship.