

CASTER INSTALLATION

D-STYLE HOPPERS

To install a caster kit:

Step 1: Elevate the hopper so that casters will fit underneath the fork tubes.

Step 2: A cluster of 4 bolt holes is located at both ends of the fork tubes. Attach casters to the underside of the tubes using $\frac{3}{8}$ in. – 16 x 1 $\frac{1}{4}$ in. bolts and corresponding washers and hex nuts.

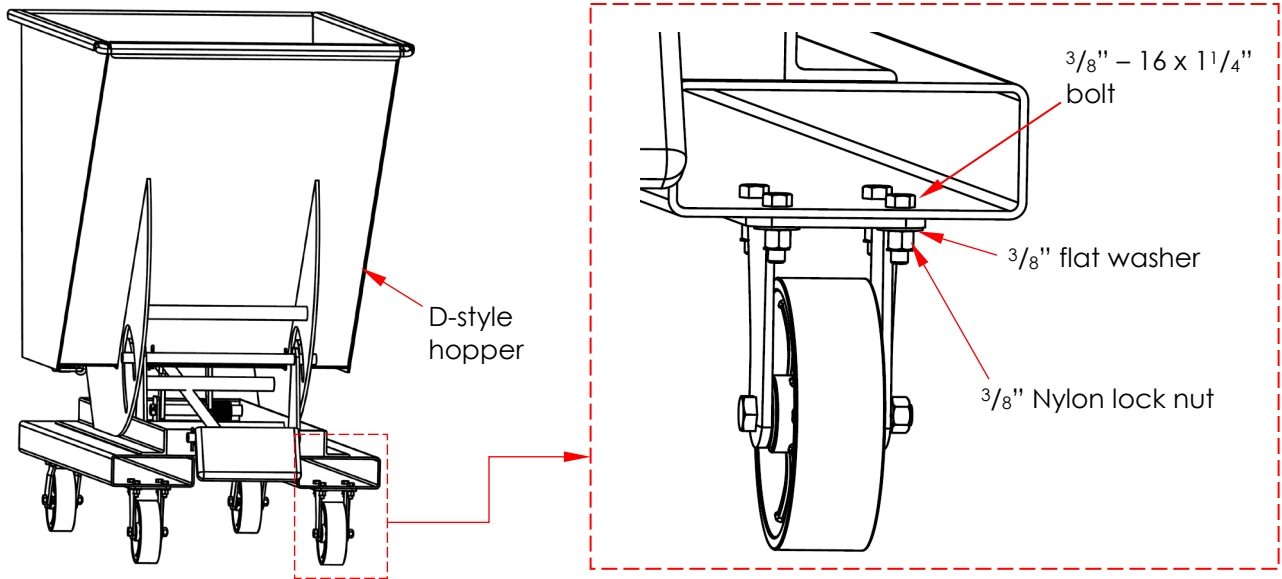

H-STYLE HOPPERS [Numbers in parentheses () correspond to item numbers]

H-25 & H-50 models: Attach foot brackets to the front end of the base frame with carriage bolts (6), flat washers (7), and lock nuts (5).

Item	Part no.	Description	Qty.
1	16-132-282	Caster 6"x2", rigid	2
2	16-132-283	Caster, 6"x2", swivel	2
3	99-612-001	Caster, retaining, bolt & nut	4
4	37-016-070	Bracket, caster, bolt-on	2
5	37024	Nylon insert lock nut, $\frac{3}{8}$ "-16, gr.2, zinc finish	16
6	21819	Carriage bolt, $\frac{3}{8}$ "-16x1 $\frac{1}{2}$ ", zinc plated	16
7	33008	Flat washer, $\frac{3}{8}$ ", low carbon, USS, zinc plated	16

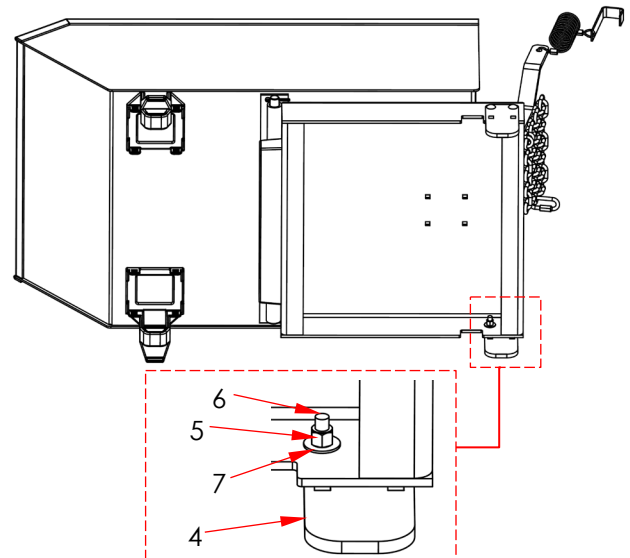
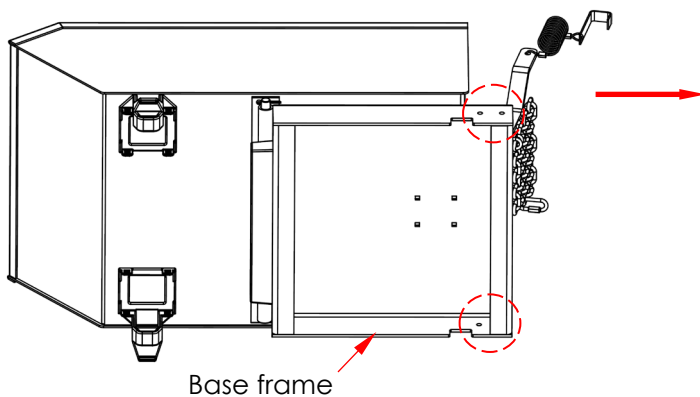
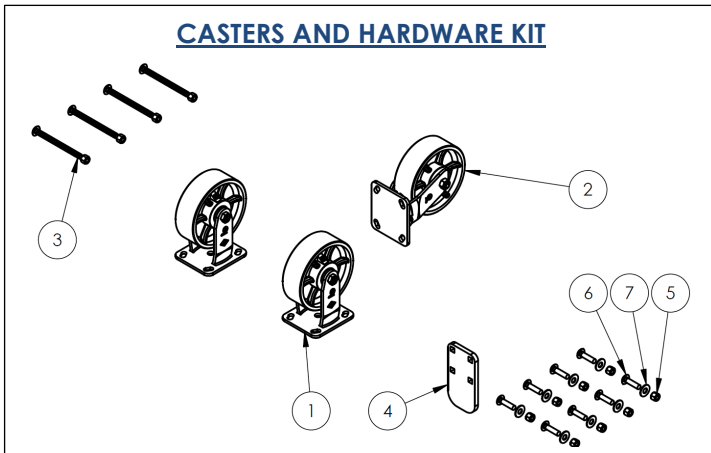

H-STYLE HOPPERS

H-25 & H-50 models (continued):

Attach casters: A) Align the bolt holes in the caster mounting plate with the bolt holes in the base frame; then fasten the caster to the base frame with $\frac{3}{8}$ "-16 hardware as shown in "Front caster installation"); B) set a caster in each quick connect caster bracket and secure it with either 1) a $\frac{3}{8}$ "-16x5" carriage bolt and a $\frac{3}{8}$ "-16 lock nut (see "Rear caster installation") or 2) a clevis pin (99-112-006) and extended prong cotter pin (65080).

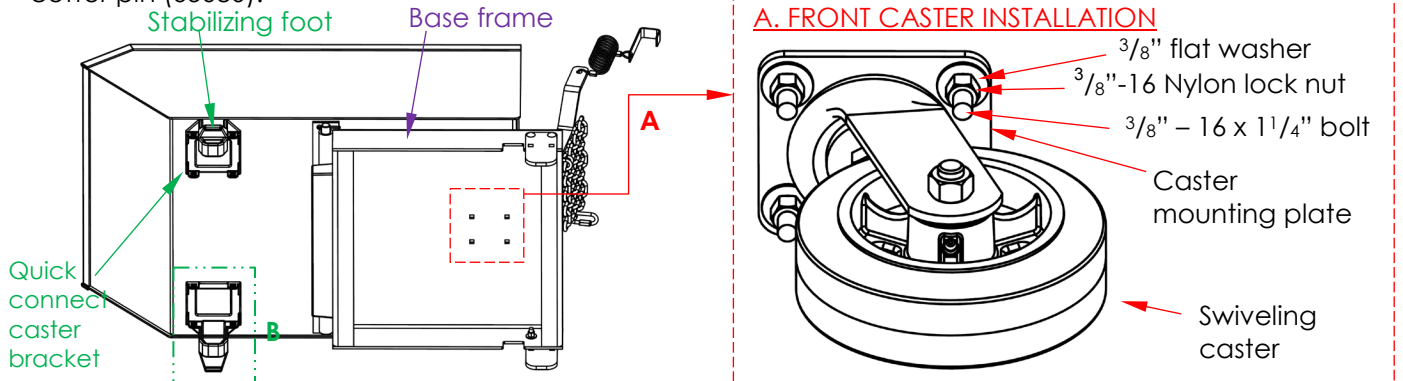

B. REAR CASTER INSTALLATION

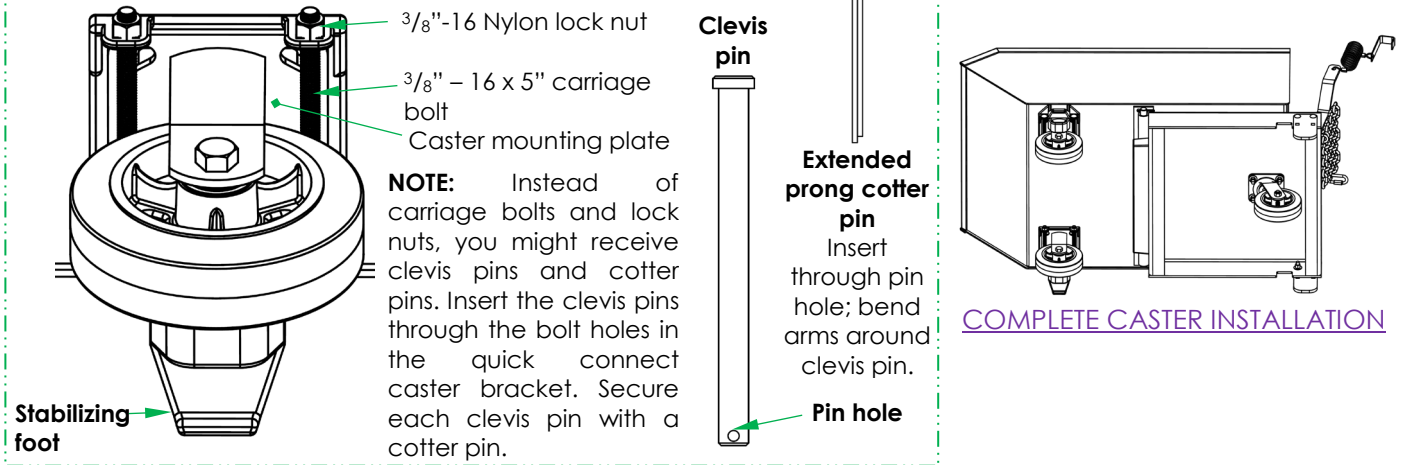

H-100 AND LARGER MODELS

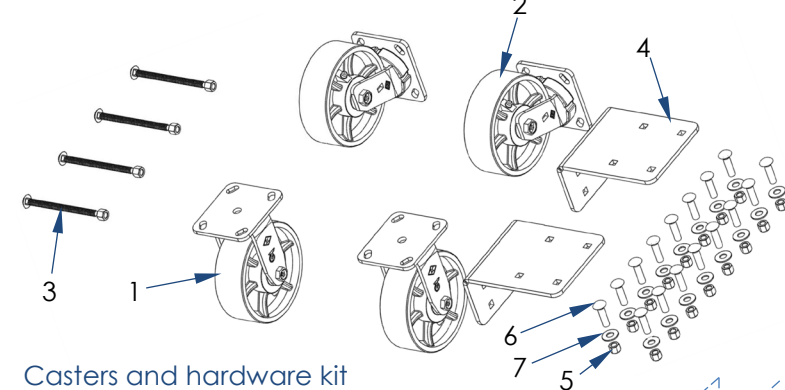

Casters and hardware kit

Fasten a swiveling caster (2) to the long arm of each caster bracket (4) with $\frac{3}{8}$ "-16x1 $\frac{1}{2}$ " carriage bolts (6), $\frac{3}{8}$ " flat washers (7), and $\frac{3}{8}$ "-16 lock nuts (5).

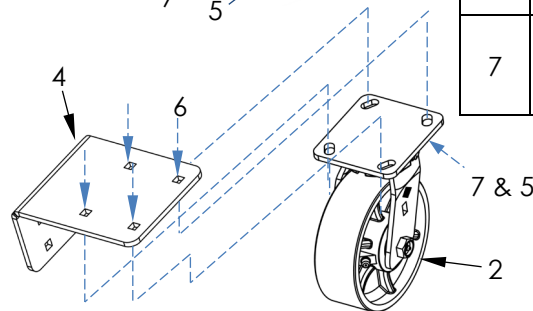

Item	Part no.	Description	Qty.
1	16-132-282	Caster 6"x2", rigid	2
2	16-132-283	Caster, 6"x2", swivel	2
3	99-612-001	Bracket bolt & nut (or clevis pin 99-112-006 and cotter pin 65080)	4
4	37-016-068	Bracket, caster, bolt-on	2
5	37024	Nylon insert lock nut, $\frac{3}{8}$ "-16, gr.2, zinc finish	16
6	21819	Carriage bolt, $\frac{3}{8}$ "-16x1 $\frac{1}{2}$ ", zinc plated	16
7	33008	Flat washer, $\frac{3}{8}$ ", low carbon, USS, zinc plated	16

H-100 and higher models (continued):

Fasten the short legs of the caster brackets (yellow) to the base frame of the hopper with carriage bolts (6), flat washers (7), and lock nuts (5).

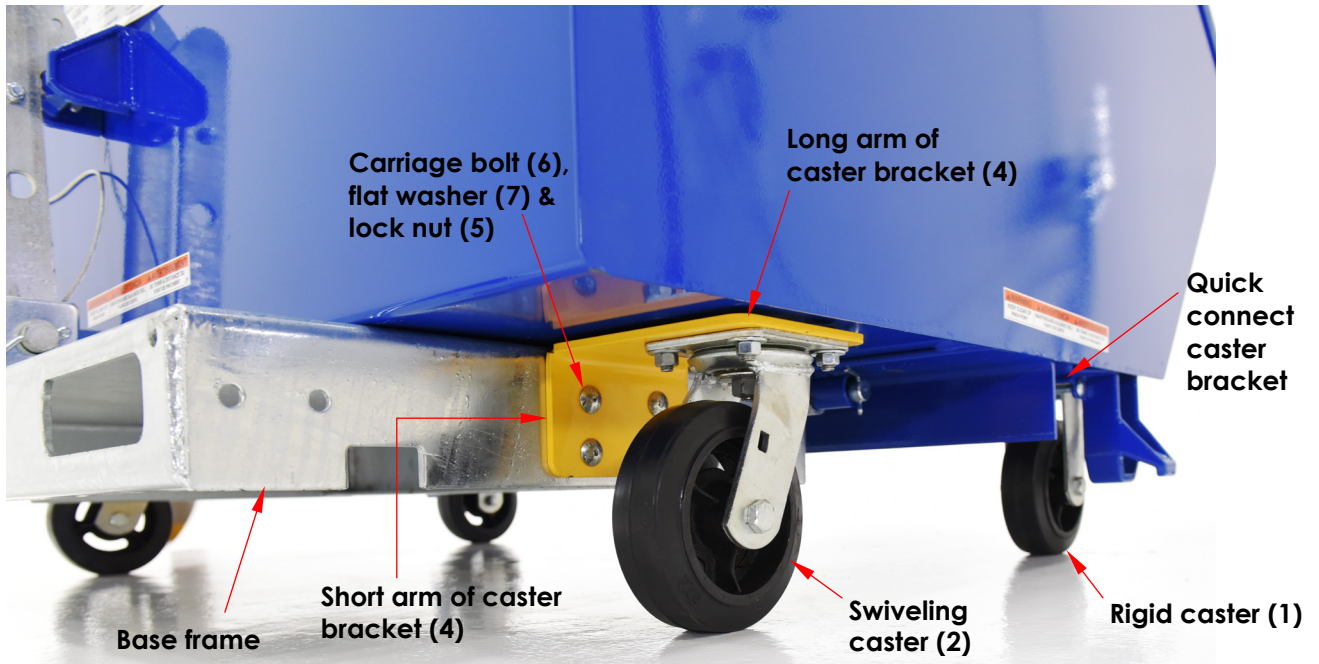

C. Insert the rigid casters into the quick connect caster brackets. Then, install 2 carriage bolts (3) through the bolt holes in each bracket and secure them with lock nuts as shown below.

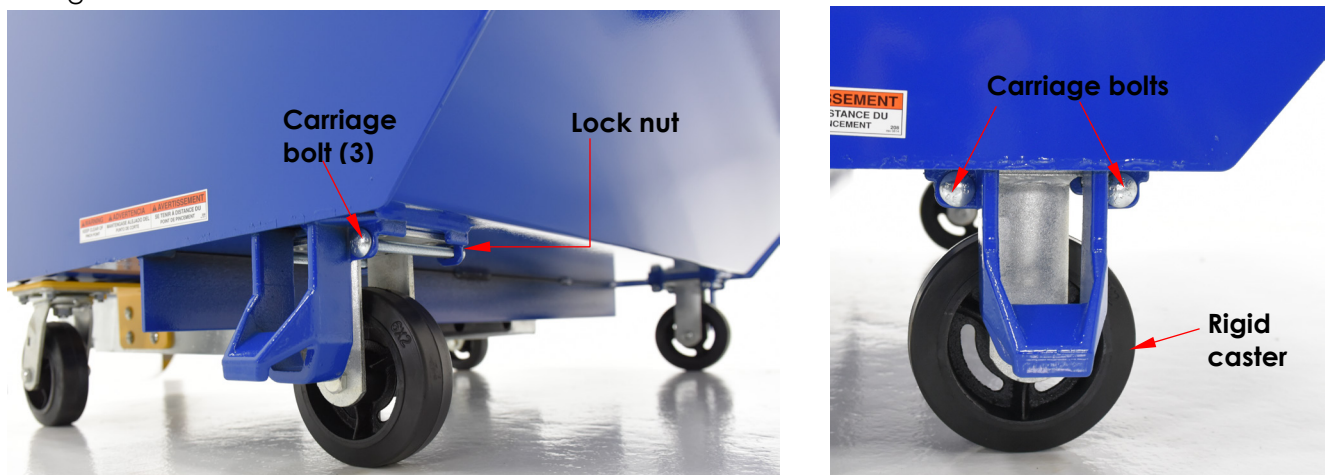

NOTE: Instead of carriage bolts and lock nuts, you might receive clevis pins (99-112-006) and extended prong cotter pins (65080). Insert the clevis pins in place of the carriage bolts. Then insert cotter pins through the pin holes in the clevis pins. Bend the arms of the cotter pins around the clevis pins.

