

PARTS LIST			
ITEM	QTY	PART NUMBER	DESCRIPTION
1	1	LSQ200-PL	1" NPT LINE STRAINER PLUG
2	1	LSQ200-RV	AS568A -123 O-RING, FKM, BROWN
4	1	MLS220C1X	2" FP MLS CAP
5	1	MLS220G1V	AS568A -241 O-RING, FKM, BROWN
6	1	MLS220R1	2" FP LS RETAINING RING
7	1	MLS222BI	MLS222 BODY WITH RIBS & INSERTS
8	1	MLS280SS	2" LST SCREEN 80 MESH W/ PERF SUPPORT

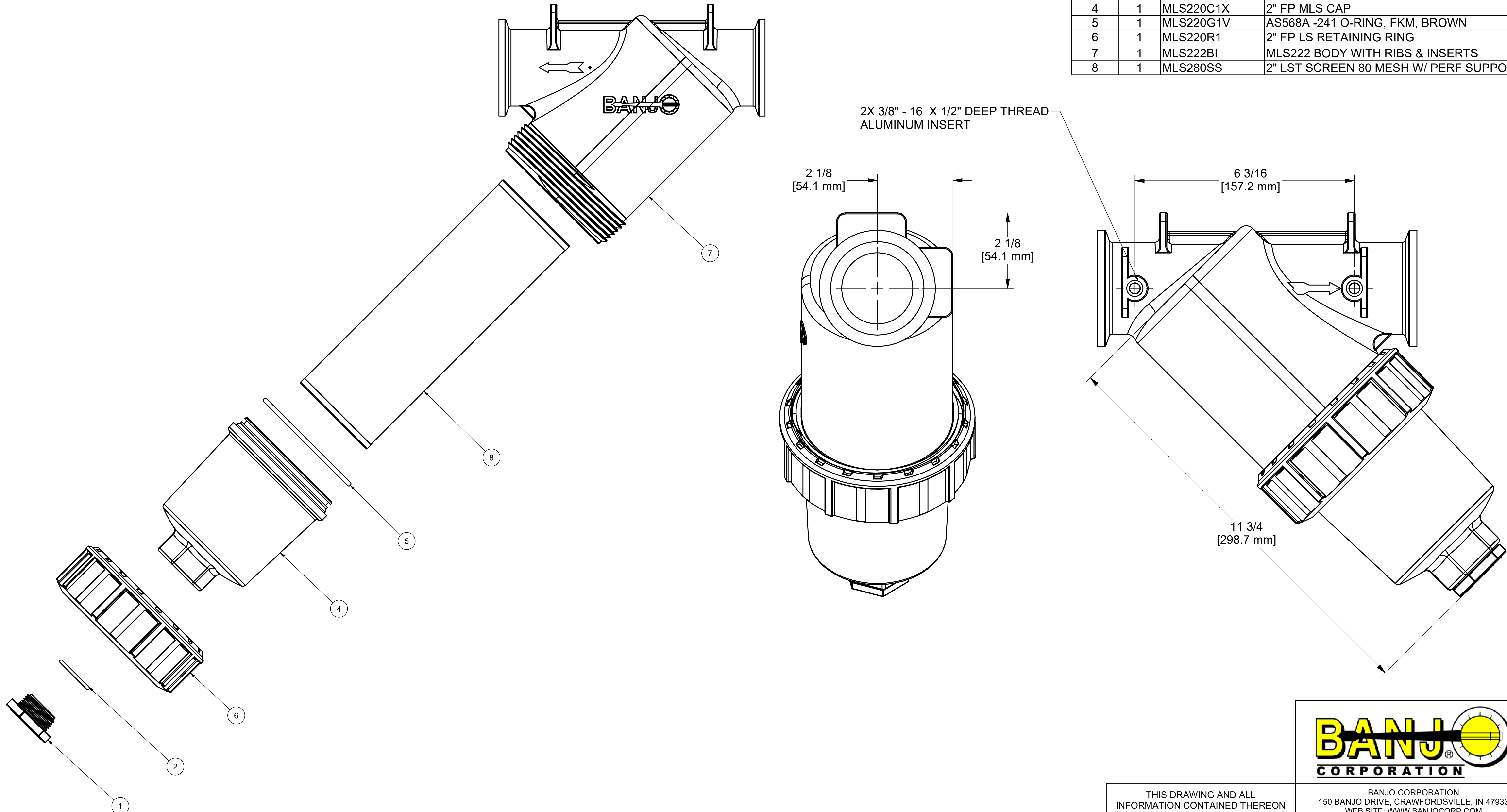

THIS DRAWING AND ALL INFORMATION CONTAINED THEREON ARE THE EXCLUSIVE PROPERTY OF BANJO CORPORATION.

UNLESS SPECIFICALLY NOTED, THIS DRAWING AND ITEMS SHOWN ON THIS DRAWING ARE SUBJECT TO CHANGE AT ANY TIME.

BANJO CORPORATION
 150 BANJO DRIVE, CRAWFORDSVILLE, IN 47933
 WEB SITE: WWW.BANJO.CORP.COM
 E-MAIL: BANJOSALES@IDEXCORP.COM

DESCRIPTION
 2" FP MNFLD LINE STRNR 80 MESH FKM

PART NUMBER
 MLS222I-80V