



ASSEMBLY INSTRUCTIONS

UltraGraphite™ Mobile Workbench (Model No. WEB484)

48 in W X 24 in D X 37.5 in H
(1.21 m x 60.9 cm x 82.5 cm)



PARTS LIST (pg 1 of 7)

Please check the parts carefully according to the parts list. If you are missing any parts, please contact our customer service department (please refer to page 7 of 7).

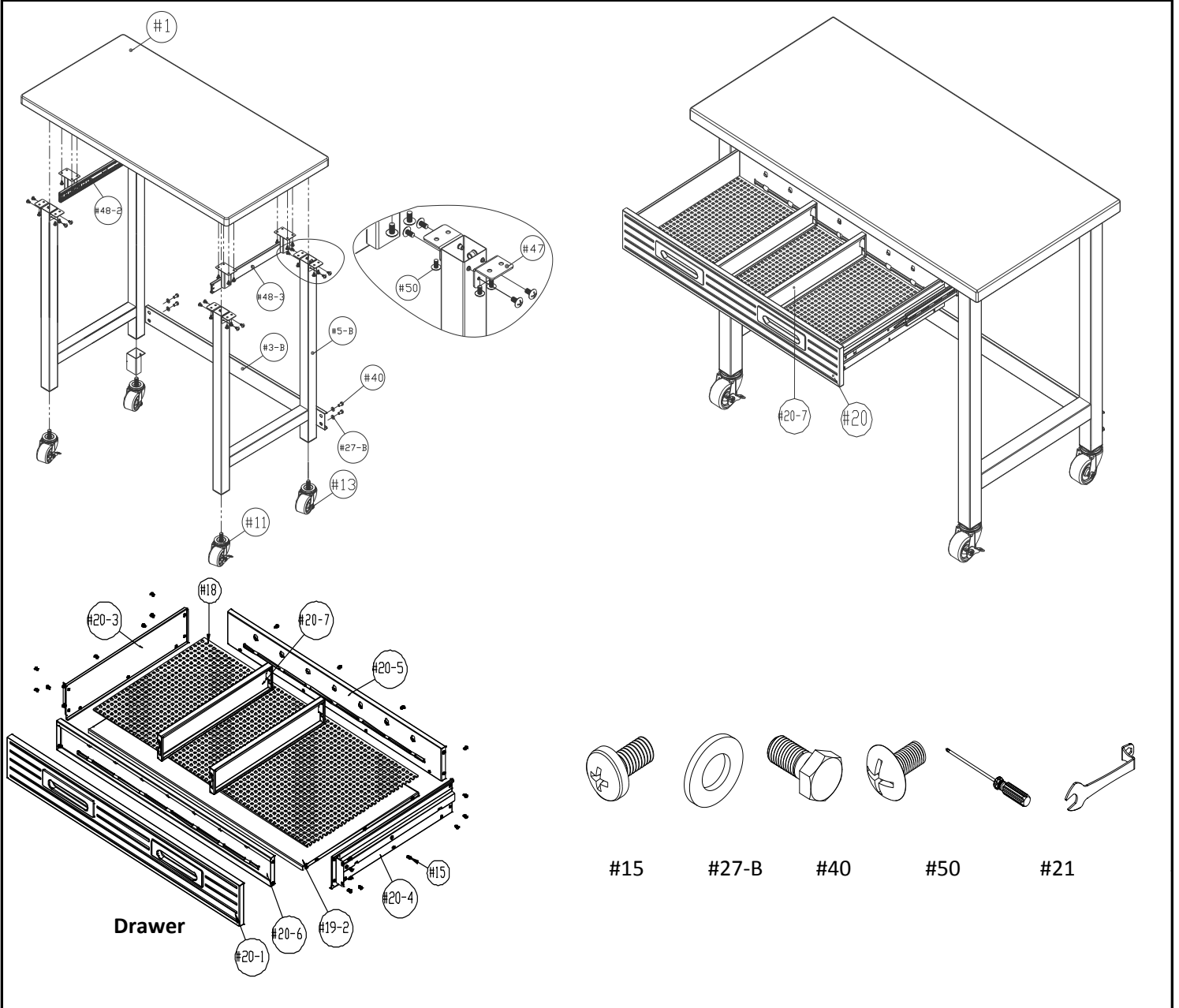

No.	Parts	Qty.
#1	SOLID HARDWOOD BOARD TOP	1 PC
#3-B	BOTTOM CROSSBAR	1 PC
#5-B	LEG PIECE	2 PCS
#11	WHEEL WITH BRAKE	2 PCS
#13	WHEEL W/O BRAKE	2 PCS
#18	DRAWER MAT	1 PC
#19-2	DRAWER BASE PANEL	1 PC
#20-1	DRAWER FRONT PANEL	1 PC
#20-3	DRAWER LEFT PANEL	1 PC
#20-4	DRAWER RIGHT PANEL	1 PC
#20-5	DRAWER BACK PANEL	1 PC

No.	Parts	Qty.
#20-6	DRAWER FRONT PANEL SUPPORT PLATE	1 PC
#20-7	DRAWER DIVIDER	2 PCS
#47	"L" BRACKET	8 PCS
#48-2	DRAWER LEFT SUPPORT	1 PC
#48-3	DRAWER RIGHT SUPPORT	1 PC
#50	SCREW I (M6 x 15L)	48 pcs
#40	SCREW E (M8 x 18L)	4 pcs
#27-B	WASHER	4 pcs
#15	SCREW B (M4 x 8L)	30 pcs
#21	SCREW DRIVER	1 pc
#25	WRENCH	1 pc

UltraGraphite™ Mobile Workbench (Model No. WEB484)

Note: We recommend TWO people to assemble the workbench.

Tip: A magnetic screwdriver is included for your convenience. If a power screwdriver is used, keep on low torque setting.

Step 1: Install (#5-B) Leg Piece.

A: Open the package, and put the parts aside. Then, attach the (#47) "L" Bracket to the (#5-B) Leg Piece, use (#50) Screw I to tighten. Repeat Step A to install (#47) "L" Brackets to another one (#5-B) Leg Piece.

Note: Tighten the all the screws after the (#47) Brackets are flush with the (#5-B) Leg Piece.

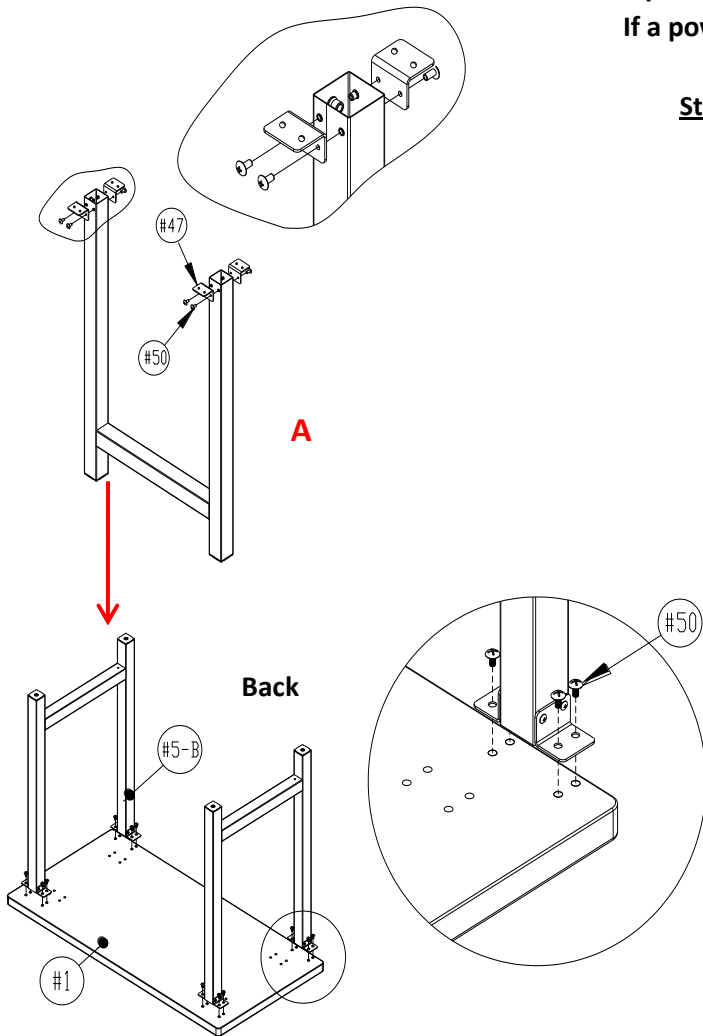

Note: Assemble the workbench on top of the cardboard packaging to help avoid scratching the solid hardwood top.

B

Step 2: Install (#48-2) Drawer Left Support, (#48-3) Drawer Right Support.

Attach the (#48-2) Small Drawer Left Support to the bottom of (#1) Solid Hardwood Board, line up the screw holes, use (#50) Screw I and (#21) Screwdriver to tighten.

NOTE: Do not fully tighten the screws. This will help you make any adjustments for alignment.

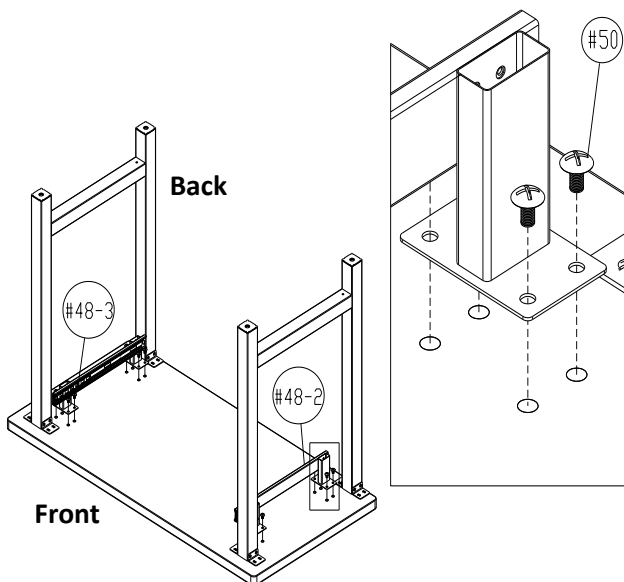

Assembly Instructions (pg 3 of 7)

UltraGraphite™ Mobile Workbench (Model No. WEB484)

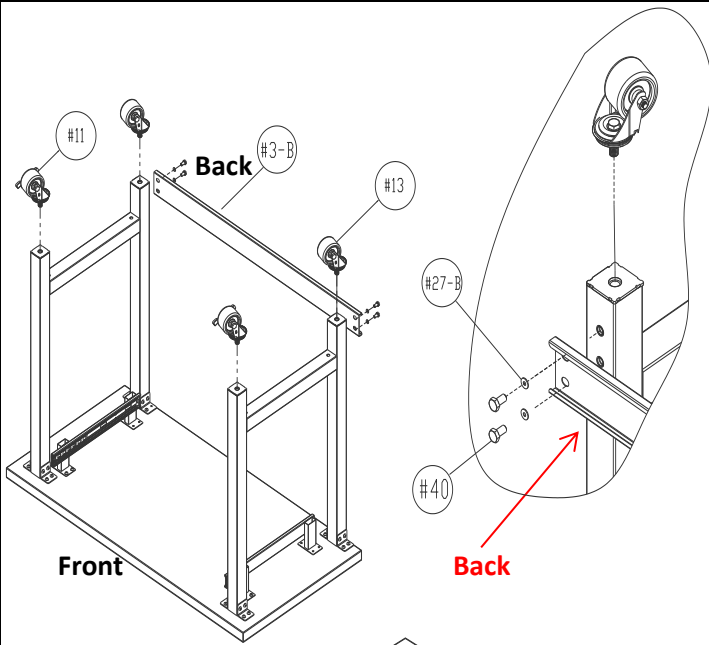

Step 3: Install (#3-B) Bottom Cross Bar and (#11) Swivel Wheel with Brake & (#13) Swivel Wheel w/o Brake.

Attach the (#3-B) Bottom Cross Bar to the back of (#5) Leg Piece, line up the screw holes, use (#40) Screw E with (#27-B) Washer and (#25) Wrench to tighten.

After installing (#5-B) Leg Pieces, attach (#11) Swivel Wheel with Brake & (#13) Swivel Wheel w/o Brake to (#5-B) Leg Pieces, use Wrench (#25) to tighten.

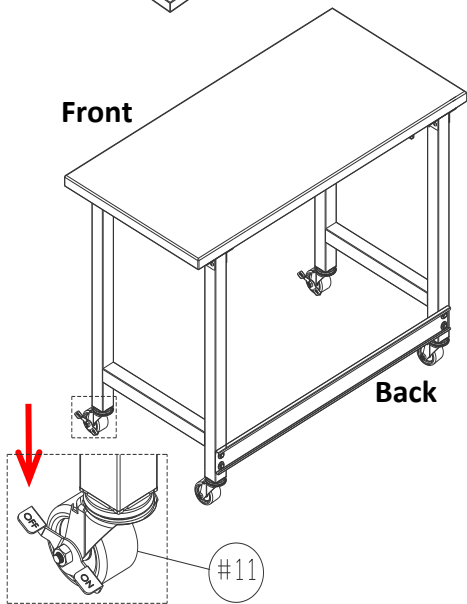

Step 4: Turn the workbench right side up once you finish this step. Step the break of the wheel (#11) as the the side photo to stable the workbench.

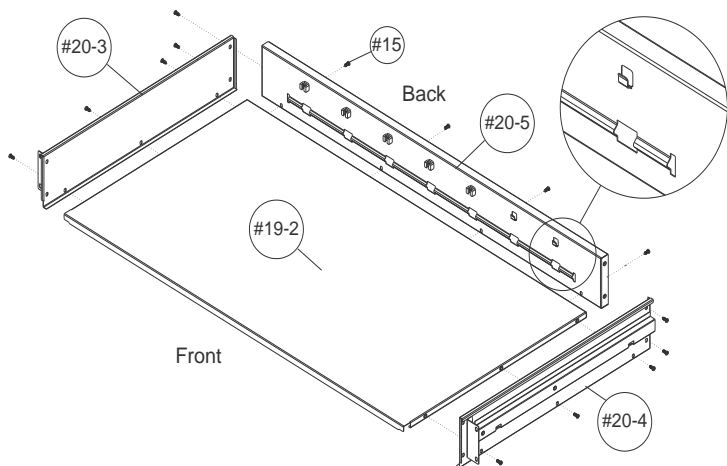

Step 5: Install (#20-3 & #20-4) Left & Right Drawer Side Panels and (#20-5) Drawer Back Panel.

Attach (#20-3 & #20-4) Left & Right Drawer Side Panels and (#20-5) Drawer Back Panel to the (#19-2) Drawer Base Panel. Line up the screw holes and use (#15) Screw B to tighten.

NOTE: Make sure the hook slots on the (#20-5) Drawer Back Panel are facing inward.

NOTE: Do not fully tighten the screws until next step had finish.

UltraGraphite™ Mobile Workbench (Model No. WEB484)

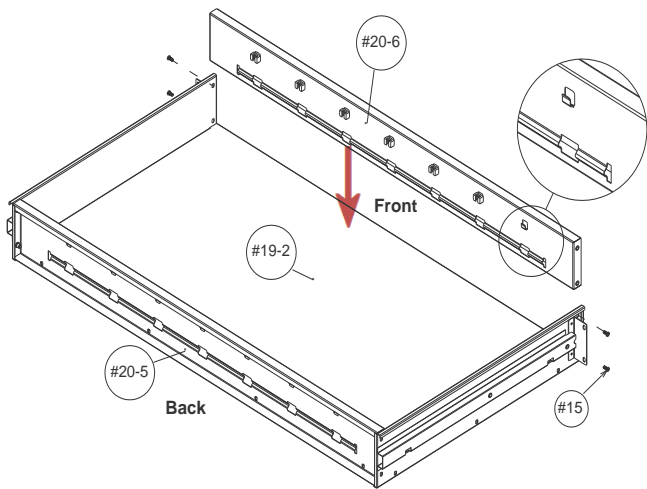

Step 6: Install (#20-6) Drawer Front Panel Support Plate

Attach (#20-6) Drawer Front Panel Support Plate as the left arrow shows. Line up the screw holes and use (#15) Screw B to tighten.

NOTE: Make sure the hook slots on the (#20-6) Drawer Front Panel Support Plate are facing inward.

NOTE: Once you adjust all the parts in position, tighten all screws.

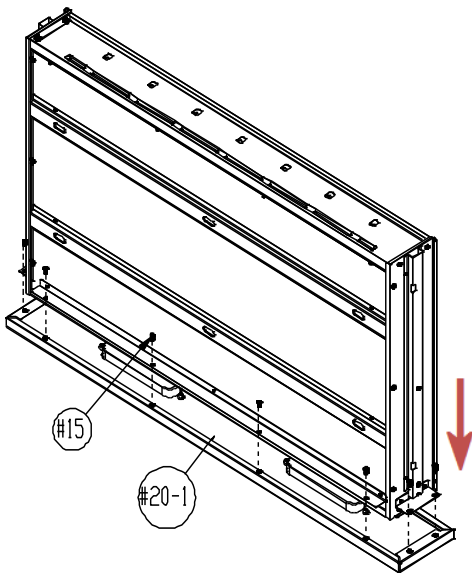

Step 7: Install (#20-1) Drawer Front Panel

Attach the Drawer Case to the (#20-1) Drawer Front Panel. Line up the screw holes and use (#15) Screw B to tighten.

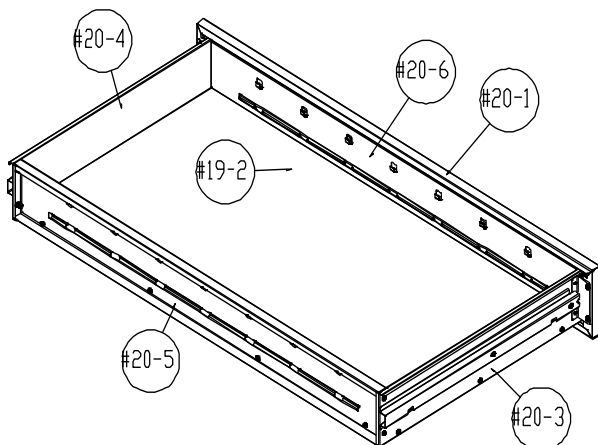

Note: Drawer's maximum loading capacity is 60 lbs to avoid the unit from tipping when drawer is fully extended.

UltraGraphite™ Mobile Workbench (Model No. WEB484)

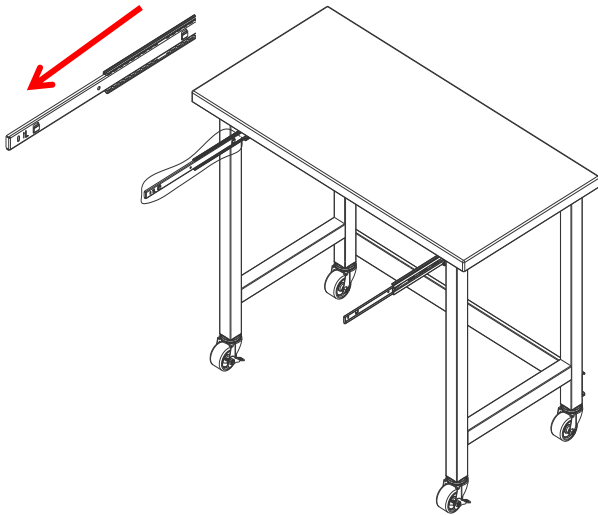

Step 8: Insert Drawer

Pull out the drawer sliders to full length, then attach and fit the Drawer to the inner track of the sliders and slide drawers in.

NOTE: Make sure to remove the rubber guards on the hooks of the inner track before fitting the drawer in.

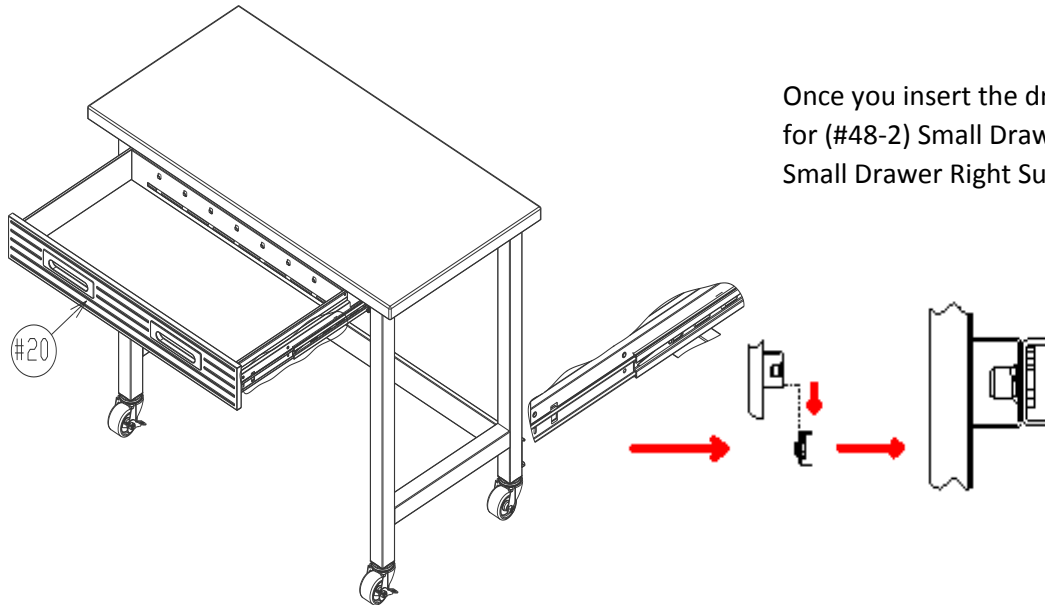

Once you insert the drawers, tighten (#15) Screw B for (#48-2) Small Drawer Left Support and (#48-3) Small Drawer Right Support.

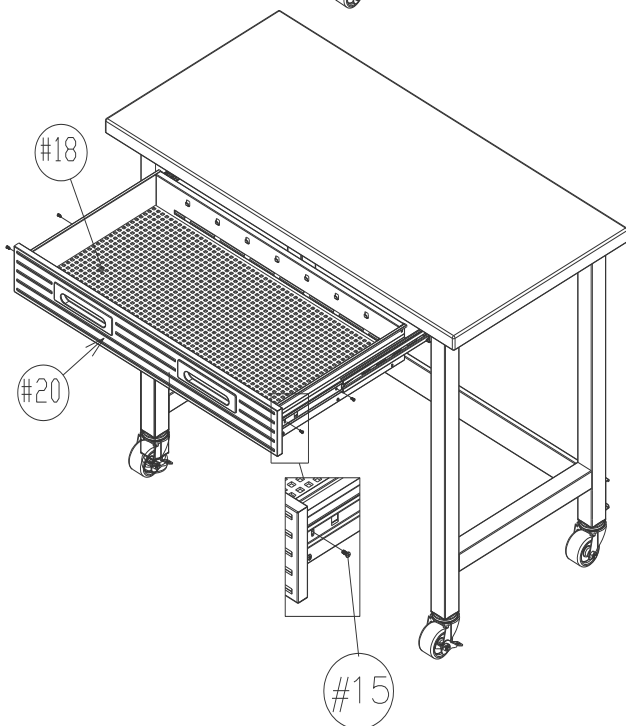

Step 9: Place (#18) Drawer Mat

After sliding in the Drawer, place (#18) Drawer Mats inside the drawer or you can place the (#18) Drawer Mat inside the drawer before you slide them in.

UltraGraphite™ Mobile Workbench (Model No. WEB484)

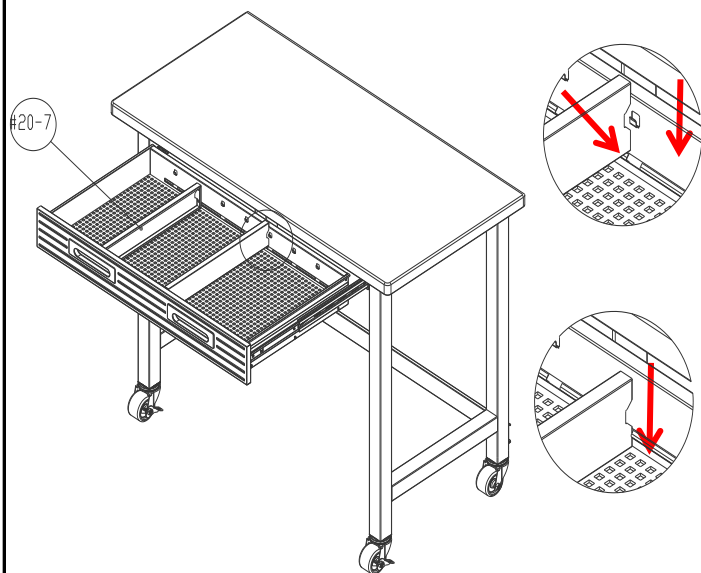

Step 10: Install (#20-7) Drawer Divider

Insert Drawer Divider into the drawer. The solid wall of the divider should be facing the desired slot position. Slide the divider towards the slot, then push down into the slot.

Repeat the above steps to assemble another Drawer Divider.

NOTE: You can assemble this step before or after the drawer is assembled on the Workbench

How to remove the Drawer Divider

Lift the Drawer Divider up and to the side to remove from the slot.

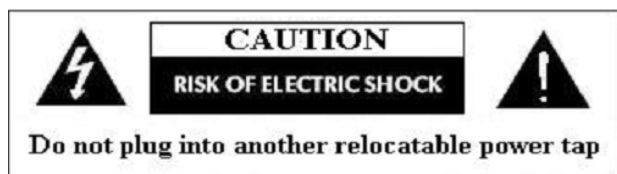

[!] CAUTION: Potential Shock or Fire Hazard. This unit is not intended for use in wet or potentially wet locations, such as showers, saunas, under or near fishtanks, sinks, etc.

Stainless Steel Maintenance:

These parts have an UltraGuard™ fingerprint resistant finish. Do not use traditional stainless steel cleaners on this unit. Lightly wipe off once a month with clean warm water and a soft cloth (preferably a microfiber cloth). This is the safest formula to prevent new stains from appearing over time and manage unwanted fingerprints or grease marks. Remember to always wipe in the direction of the surface grain (NEVER ACROSS) and always use a lint-free cloth. Once the surface is clean, thoroughly wipe dry with a soft absorbent cloth.

UltraHD Wood Top

Although great care is taken to hand select consistent wood top color and grain for UltraHD products, there can and will be natural variations in color and graining between finished products. These variations contribute to the beauty of using a natural material as a workbench and are considered standard quality. Variations of color within these standards and minor scratches in the clear coat finish will not be a reason for replacement. If the wood top is received with excessive damage or splitting, Seville Classics will guarantee replacement of the wood top.

Restore Shallow Scratches or Chips

If the wood top becomes scratched and chipped over time or during assembly, a Polyurethane finish can be applied to help restore the wood's natural texture, as well as protect the surface from future damage.

Applying a Polyurethane Coating

Please follow the manufacturer's instruction on the product for application.

CONTACT INFORMATION (pg 7 of 7)

*If you are missing any parts, have any questions, or need additional assistance in assembly, please contact our bilingual (English/Spanish) customer service department at:



Seville Classics, Inc.
19401 South Harborgate Way
Torrance, CA 90501
USA

Telephone: (800) 323-5565 within USA

Hours: 9:00am - 4:30pm (Pacific Standard Time)

Fax: (310) 533-3899

E-mail: support@sevilleclassics.com

Website & Online Store: www.sevilleclassics.com

*****Please visit our website or call and inquire about our additional UltraHD Line*****

UltraHD Line

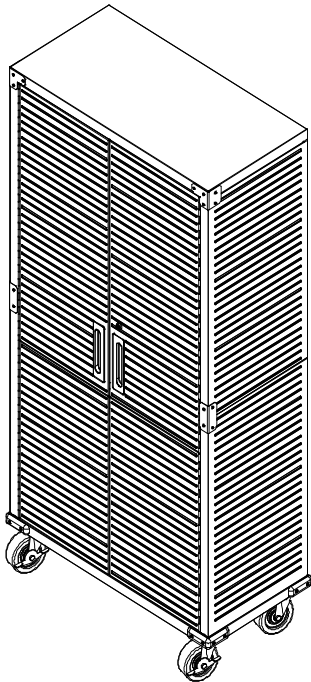

Model No. 16236
UltraHD Storage Cabinet

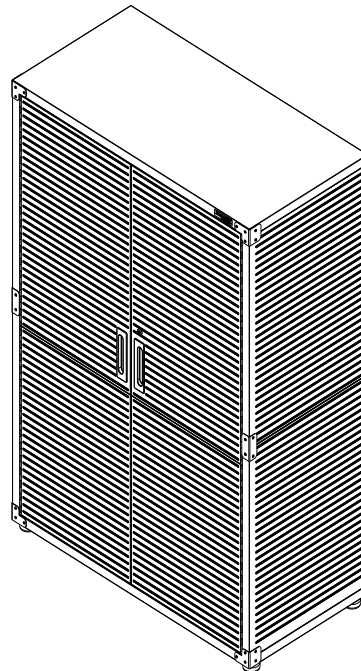

Model No. 16238
UltraHD Rolling Cabinet

UltraHD Line

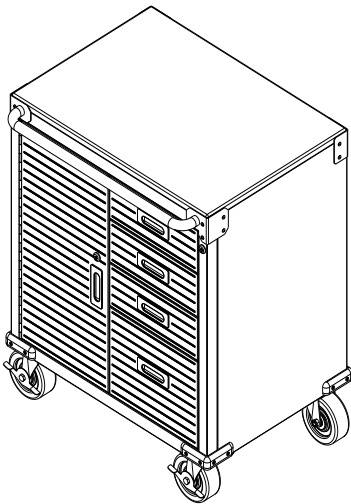

Model No. 20225
UltraHD Rolling Cabinet

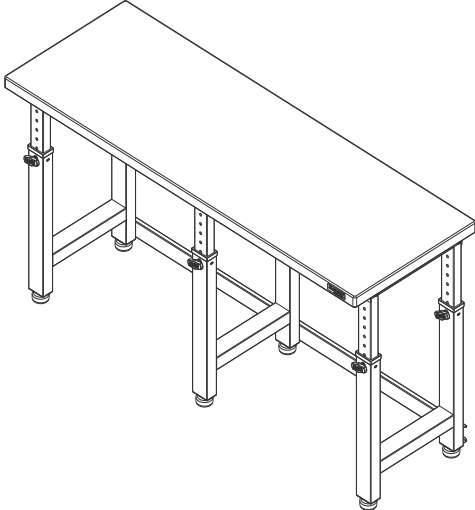

Model No. 20296
UltraHD Height Adjustable Workbench

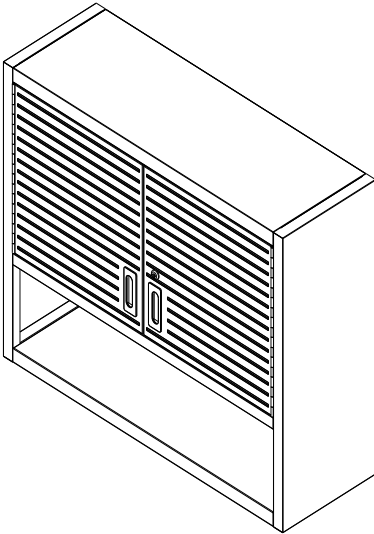

Model No. 20230
UltraHD Wall Cabinet

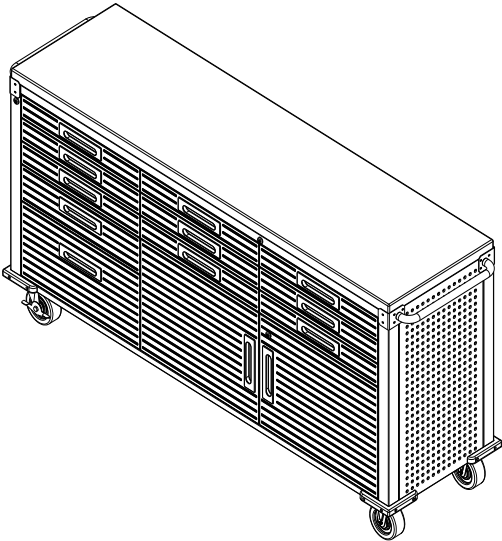

Model No. 20262
UltraHD Rolling Workbench

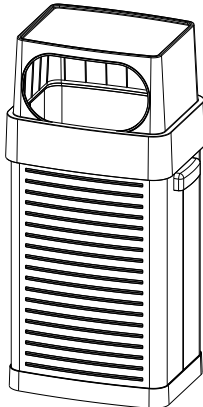

Model No. 20217
UltraHD Trash Bin

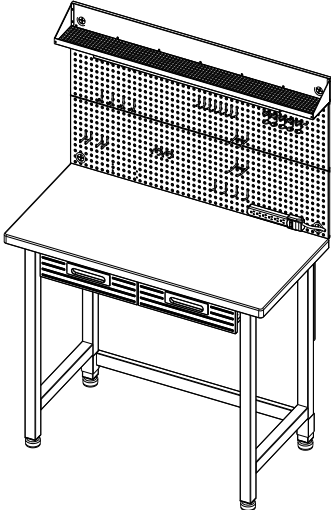

Model No. 20247
UltraHD Lighted Workcenter