

ASSEMBLY INSTRUCTIONS
INSTRUCCIONES DE MONTAJE
INSTRUCCIONES DE ENSAMBLAJE

8962

Refreshment Center
Centrez pour les Rafrâichissements
Centre para los Refrescos



PRODUCT WARRANTY REGISTRATION is available online at: www.safcoproducts.com

• L'INSCRIPTION POUR LA GARANTIE DU PRODUIT est disponible sur l'Internet : www.safcoproducts.com

• EI REGISTRO PARA LA GARANTÍA DEL PRODUCTO está disponible en la Internet: www.safcoproducts.com

For questions or concerns, please call **1-800-664-0042**
available Monday-Friday 7:00 AM to 6:00 PM (Central Time) (English-speaking operators)

Si vous avez des questions pour poser ou les préoccupations pour exprimer, connecter **au 1-800-664-0042**
de 7H00 à 18H00 (Heure centrale) (Opérateurs de langue anglaise)

Si usted tiene preguntas o preocupaciones, por favor llame **1-800-664-0042**
de 7:00 AM a 6:00 PM (Hora Central) (Operadores que hablan inglés)

TOOLS REQUIRED: Flat-bladed Screwdriver; Phillips Screwdriver; Hammer or Mallet
OUTILS REQUIS : *Tournevis plat à lame ; tournevis à pointe cruciforme ; marteau ou maillet*
HERRAMIENTAS REQUERIDAS: Piso aspas destornillador; destornillador Phillips; martillo o mazo

Parts List / Liste des Pièces / Lista de Piezas

Code/ Código	DESCRIPTION / DESCRIPTION / DESCRIPCIÓN	Qty./ Qté/ Cant.	Part No./ N° de Pièce / No. de Pieza
(A)	Left Side Panel / <i>Panneau du côté gauche</i> / Tablero lateral izquierdo	1	8962-02\$
(B)	Right Side Panel / <i>Panneau du côté droit</i> / Tablero lateral derecho	1	8962-03\$
(C)	Half Shelf / <i>Demie étagère</i> / Medio-estante	1	8962-07\$
(D)	Back Panel / <i>Panneau arrière</i> / Tablero trasero	1	8962-04\$
(E)	Bottom Panel / <i>Panneau inférieur</i> / Tablero del fondo	1	896205\$
(F)	Left Door Panel / <i>Panneau de la porte, gauche</i> / Panel de puerta, izquierda	1	8962-08\$
(G)	Right Door Panel / <i>Panneau de la porte, droit</i> / Panel de puerta, derecho	1	8962-09\$
(H)	Adjustable Shelf / <i>Étagère ajustable</i> / Estante ajustable	1	8962-06\$
(I)	Top Panel / <i>Panneau supérieur</i> / Tablero superior	1	8962-01\$
(J)	Drop Leaf / <i>Étagère à rallonges</i> / Estante de la gota-hoja	2	8962-10\$
(K)	Drawer Side / <i>Panneau latéral pour Tiroir</i> / Tablero lateral para el Cajón	2	8962-20
(L)	Drawer Back / <i>Panneau arrière pour Tiroir</i> / Tablero trasero para el Cajón	1	8962-13
(M)	Inner Drawer Front / <i>Panneau intérieur pour de devant du Tiroir</i> / Tablero interno para el Frente del Cajón	1	8962-12
(N)	Drawer Bottom / <i>Panneau inférieur pour Tiroir</i> / Tablero del fondo para el Cajón	1	8962-22
(O)	Outer Drawer Front / <i>Panneau externe pour de devant du Tiroir</i> / Tablero exterior para el Frente del Cajón	1	8962-11\$
(P)	Left Cabinet Rail / <i>Rail de l'Armoire gauche</i> / Guía de patín izquierda para el Mueble	1	1905-15
(Q)	Right Cabinet Rail / <i>Rail de l'Armoire droit</i> / Guía de patín derecha para el Mueble	1	1905-16
(R)	Left Drawer Rail / <i>Rail du Tiroir gauche</i> / Guía de patín izquierda para el Cajón	1	8962-17
(S)	Right Drawer Rail / <i>Rail du Tiroir droit</i> / Guía de patín derecha para el Cajón	1	8962-18
(T)	Piano Hinge / <i>Charnière du piano</i> / Charnela de piano-estilo	2	8962-29
(U)	Drop Leaf Hinge / <i>Charnière à rallonges</i> / Charnela de la gota-hoja	2	8962-30
(V)	Hardware Pack / <i>Paquet Matériel</i> / Paquete Material	1	8962-19BL
(W)	Hardware Pack / <i>Paquet Matériel</i> / Paquete Material	1	8918-99\$

Two People Recommended.

On recommande que l'assemblage soit effectué par deux personnes.



Se recomienda dos personas para el ensamblaje.

§Note: When corresponding about parts, be sure to state color: Mahogany (MH) or Medium Oak (MO)





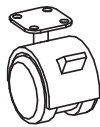





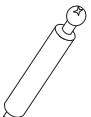
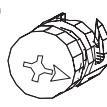

§ Noter: Quand correspondre au sujet de parties, soyez sûr d'affirmer la couleur: Acajou (MH) ou Chêne Moyen (MO).

§ Note: Al corresponder sobre las piezas, esté seguro declarar el color: Caoba (MH) o Roble Pálido (MO).

**Hardware Pack /
Paquet Matériel / Paquete
Material:
8918-99BL**

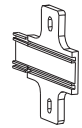
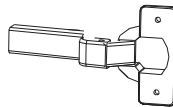
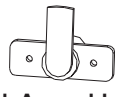
LL  Caster With Brakes <i>Roue avec Frein</i> Rueda con Freno Qty. / Qté. / Cant. 2 8918-24	MM  Caster Without Brakes <i>Roue sans Frein</i> Rueda sin Freno Qty. / Qté. / Cant. 2 8918-25
---	--

**Hardware Pack /
Paquet Matériel / Paquete Material:
8962-19NC**

X  Long Screw Post <i>Long Poteau avec la fin d'un vis</i> Poste largo con el tornillo-extremo Qty. / Qté. / Cant. 18 HFFMFB	Y  Locking Cam <i>Came</i> Leva del freno Qty. / Qté. / Cant. 18 HFFMFC	Z  Door Plate <i>Plaque de la porte</i> Plato de la puerta Qty. / Qté. / Cant. 1 8919-15	AA  Lock Plate <i>Plaque de la serrure</i> Placa de fijación Qty. / Qté. / Cant. 1 3695-15	BB  Screw, 1/2" Long (Coarse Thread) <i>Vis (grossier filetage)</i> Tornillo (de rosca gruesa) Qty. / Qté. / Cant. 40 3695-28	CC  Screw, 5/8" Long <i>Vis, 5/8" L</i> Tornillo, 5/8"L Qty. / Qté. / Cant. 16 8918-22	DD  Screw, Drawer <i>Vis pour tiroir</i> Tornillo para cajón Qty. / Qté. / Cant. 8 8962-27
EE  Screw, Handle <i>Vis du manche</i> Tornillo del asa Qty. / Qté. / Cant. 4 8962-26	FF  Drawer Handle <i>Manche pour tiroir</i> Asa de cajón Qty. / Qté. / Cant. 2 8962-31	GG  Hinge Mount Plate <i>Plaque de montage de la charnière</i> Plato de montura de charnela Qty. / Qté. / Cant. 4 8919-14	HH  Hinge <i>Charnière</i> Charnela Qty. / Qté. / Cant. 4 8919-16	II  Lock Assembly w/ Keys <i>Assemblée de la serrure avec les Clefs</i> Cierre con llave la asamblea con llaves Qty. / Qté. / Cant. 1 3695-13	JJ  Shelf Peg <i>Piquet de l'étagère</i> Clavija del Estante Qty. / Qté. / Cant. 4 HSFBNZ	LL  Screw, 1/2", Black <i>Petit Vis, 1/2", Noir</i> Tornillo, 1/2", Negro Qty. / Qté. / Cant. 4 3695-28BL
KK  Door Handle <i>Manche de la porte</i> Asa para la puerta Qty. / Qté. / Cant. 2 8962-32BL	MM  Screw, 1/2" Long (Fine Thread) <i>Vis (filetage fin)</i> Tornillo (de rosca fina) Qty. / Qté. / Cant. 1 8919-28					

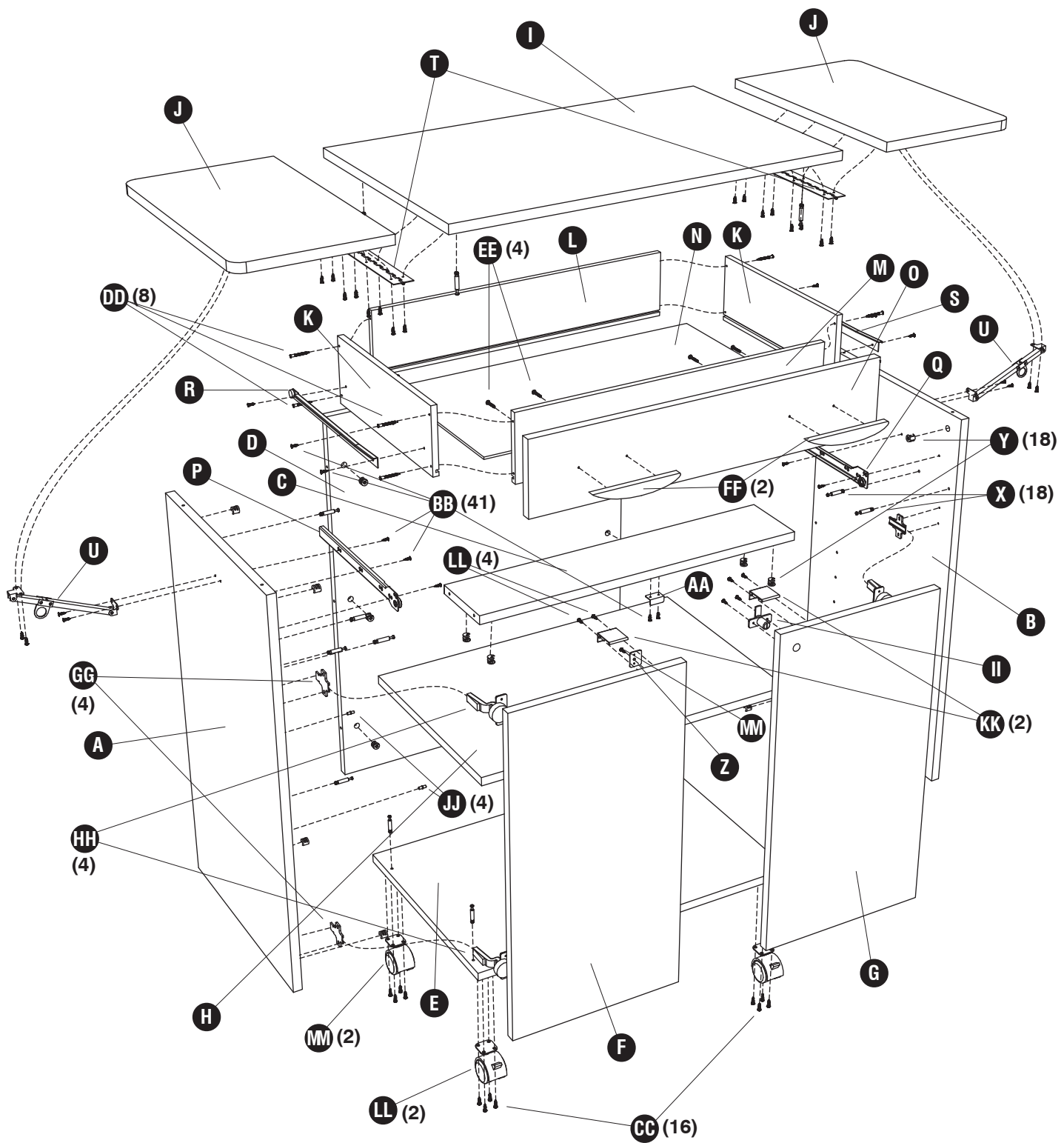

1 Properly identify the four types of rails used!

The Cabinet Rails P, Q have C-shaped cross sections; rollers are at the FRONT, and the Left Cabinet Rail is stamped "CL" near the roller, while the Right Cabinet Rail is stamped "CR".

The Drawer Rails R, S have L-shaped sections; rollers are at the BACK, and they are stamped "DR" for Right and "DL" for Left.

Correctement identifiez les quatre types de rails utilisés !

Les Rails de l'Armoire P, Q ayez des sections transversales qui sont C - Façonnées; les rouleaux sont au DEVANT, et le Rail de l'Armoire Gauche est estampillé " CL " près le rouleau, pendant que le Rail de l'Armoire Droit est estampillé " CR ".

Les Rails du Tiroir R, S ayez des sections transversales qui sont L - Façonnées; les rouleaux sont à l'ARRIÈRE, et ils sont estampillés " DR " pour Droit et " DL " pour Gauche.

¡Propiamente identifique los cuatro tipos de barras usados!

Las guías de patín para el Mueble P, Q tiene secciones transversales que se C-forman; los rodillos están en el FRENTE, y la guía de patín Izquierda para el Mueble es el " CL " estampillado cerca del rodillo, mientras la guía de patín Derecha para el Mueble es " CR " estampillado.

Las guías de patín para el Cajón R, S tiene secciones transversales que se L-forman; los rodillos son al TRASERO, y ellos son " DR " estampillado para el Derecho y " DL " para la Izquierda.

USE THIS HOLE FOR FRONT SCREW
UTILISEZ CE TROU POUR VIS DE DEVANT
USE ESTE AGUJERO PARA EL TORNILLO DELANTERO

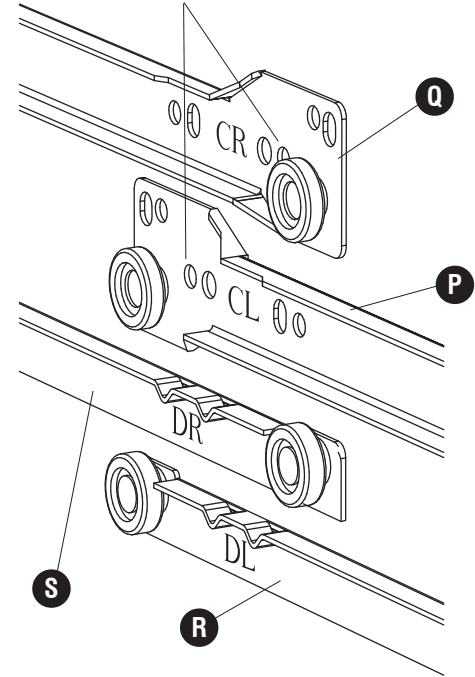

2

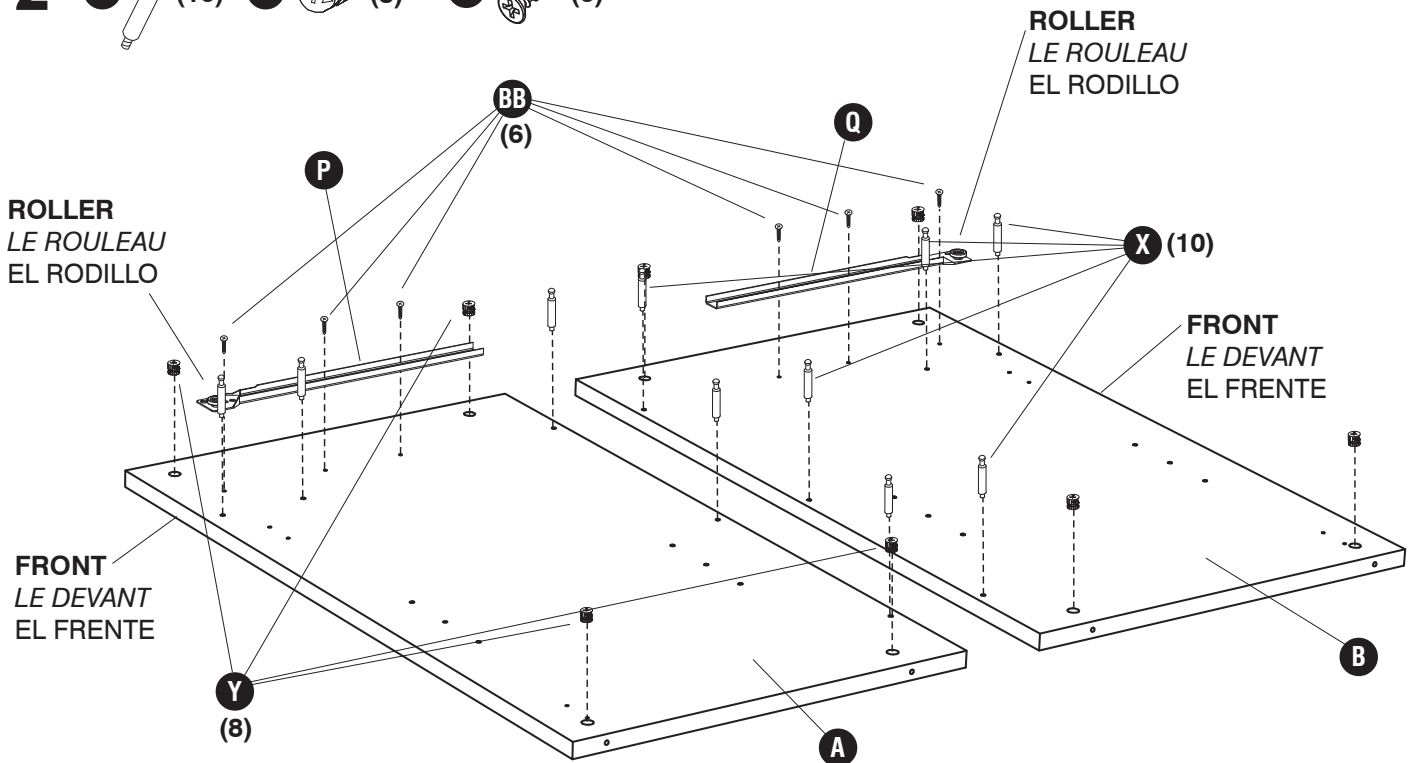

3

X

(4)

Y

(10)

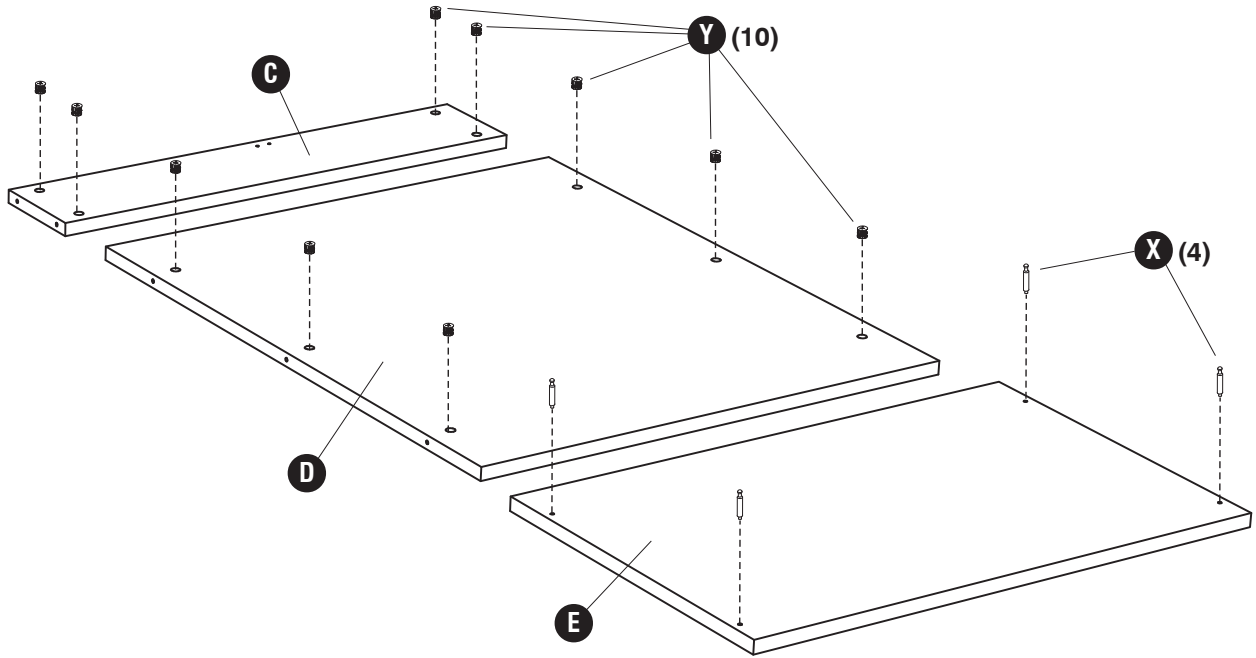

4

ROLLER
LE ROULEAU
EL RODILLO

Two People Recommended.
On recommande que l'assemblage soit effectué par deux personnes.
Se recomienda dos personas para el ensamblaje.

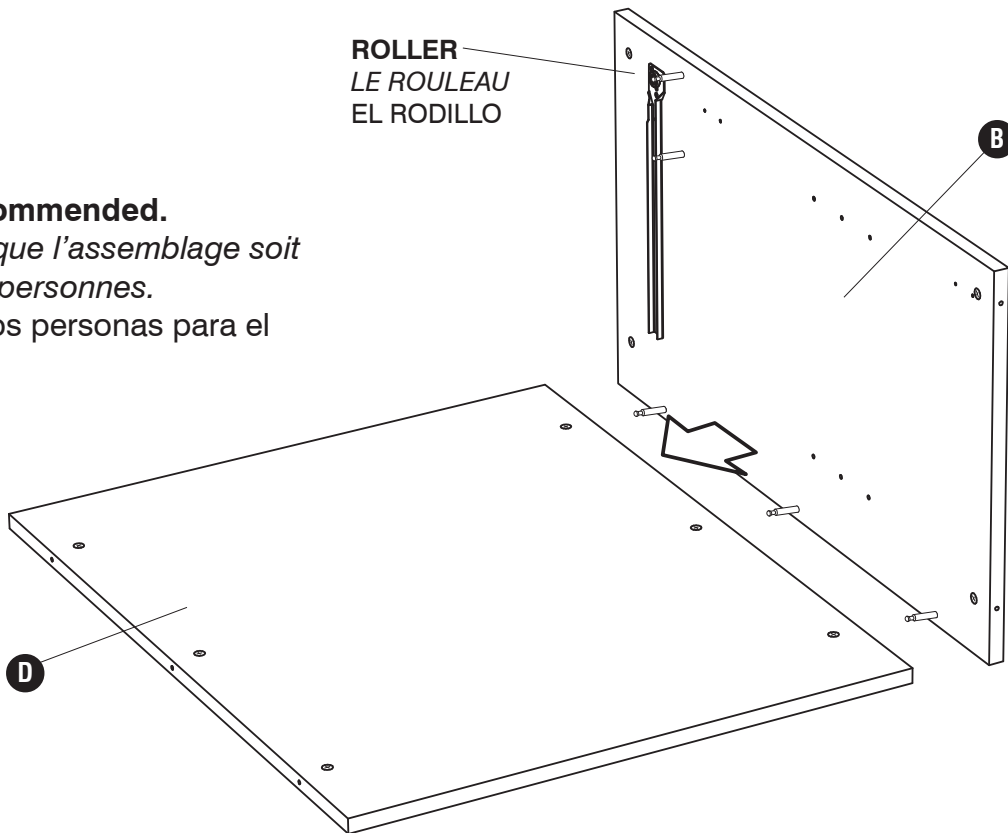

5 Two People Recommended.

On recommande que l'assemblage soit effectué par deux personnes.

Se recomienda dos personas para el ensamblaje.

FRONT AND BOTTOM
LE DEVANT ET LE FOND
EL FRENTE Y EL FONDO

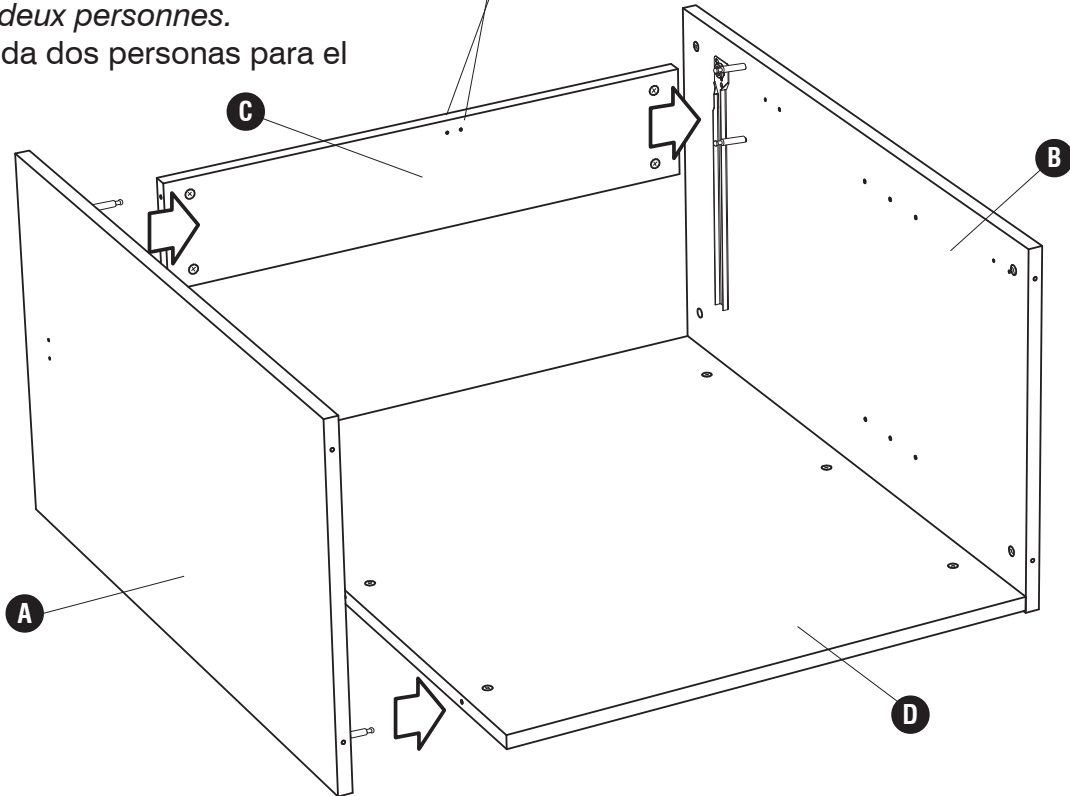

6 Bottom and sides are flush with each other

Le fond et les côtés sont alignés

El fondo y las paredes se alinean unos con otros

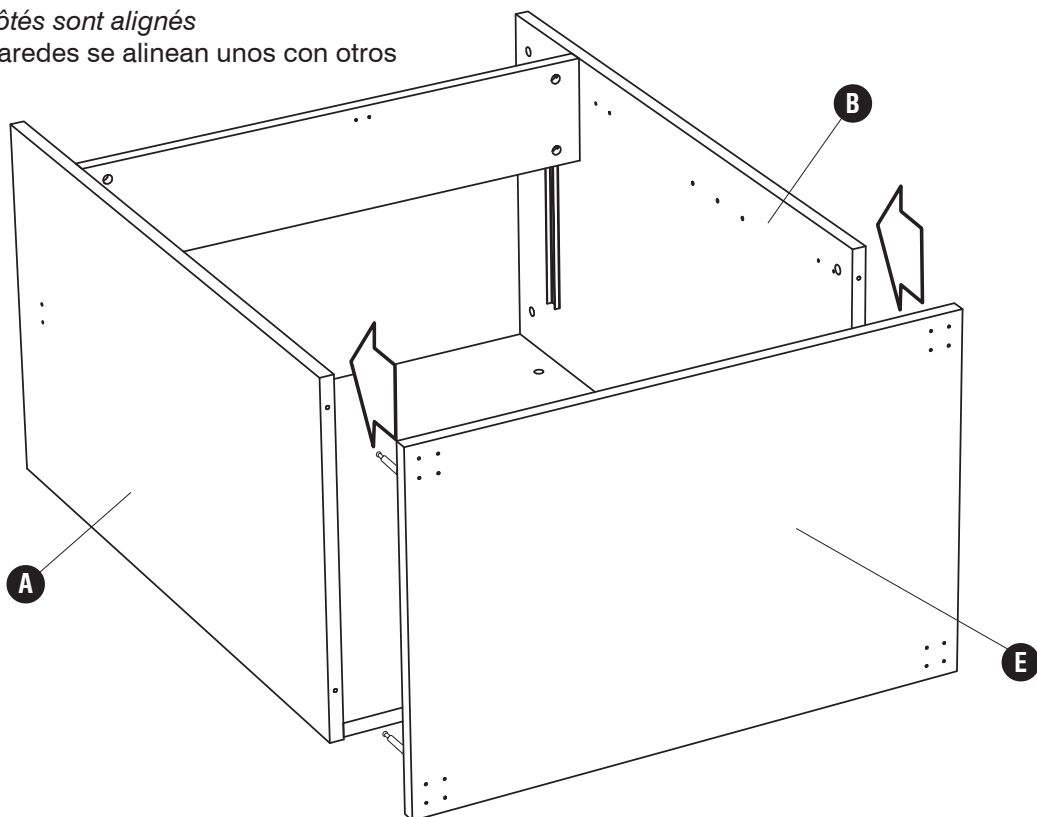

7 **CC** (16) **LL** (2) **MM** (2)

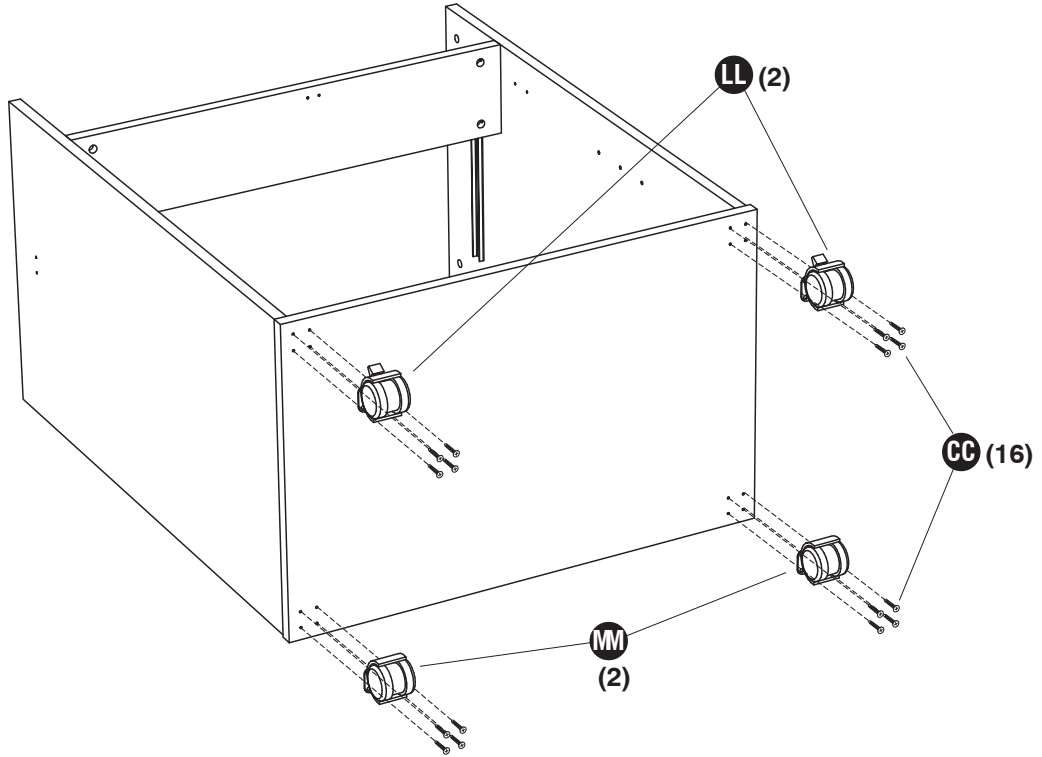

8 **Z** (1) **MM** (1) **GG** (2) **HH** (2)

**ARM
BRAS
BRAZO**

HH

**SLOT
FENTE
RANURA**

GG

**SET SCREW
VIS DE FIXATION
TORNILLO
DE FIJACIÓN**

**TIGHTEN
SET SCREW
SERRER LA VIS
APRETAR EL TORNILLO
DE FIJACIÓN**

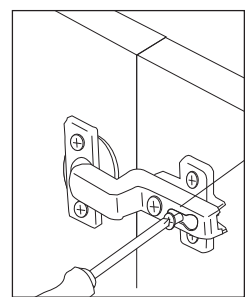
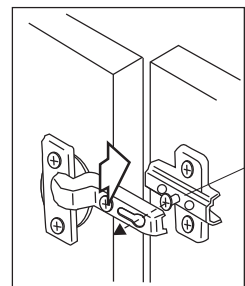
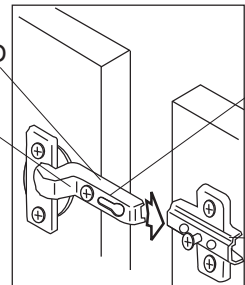
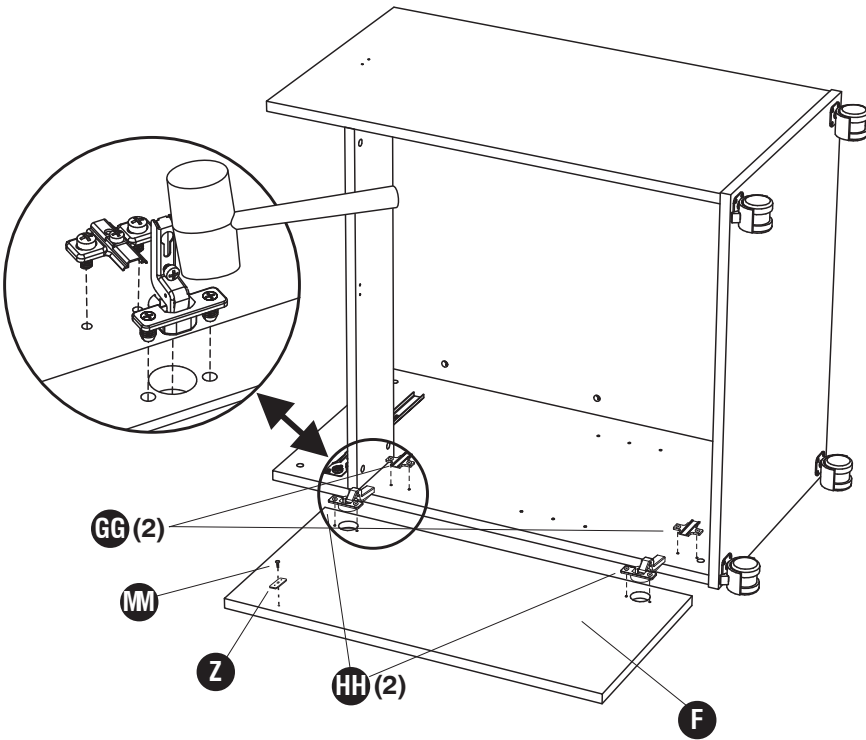

9 GG (2) HH (2)

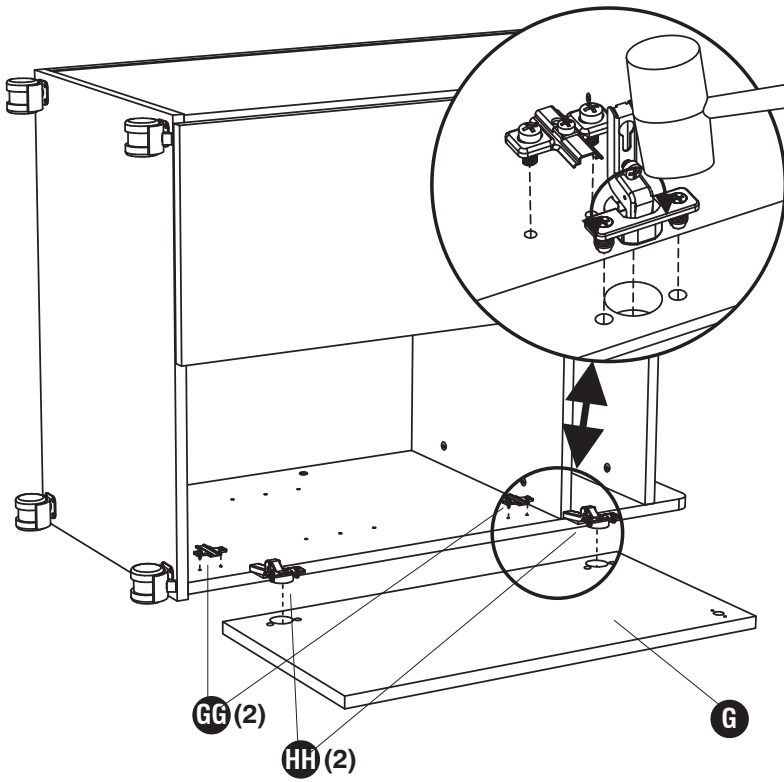

SLOT
FENTE
RANURA

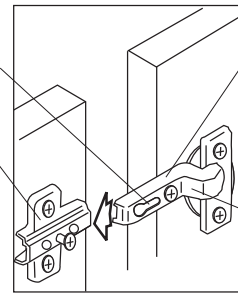

ARM
BRAS
BRAZO

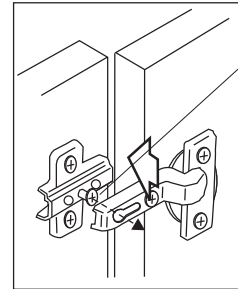

SET SCREW
VIS DE FIXATION
TORNILLO
DE FIJACION

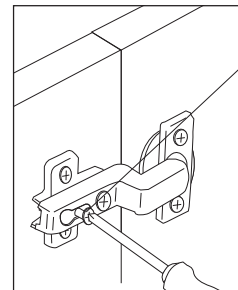

TIGHTEN
SET SCREW
SERRER LA VIS
APRETAR EL TORNILLO
DE FIJACION

10 AA (1) BB (4) II (1) JJ (4)

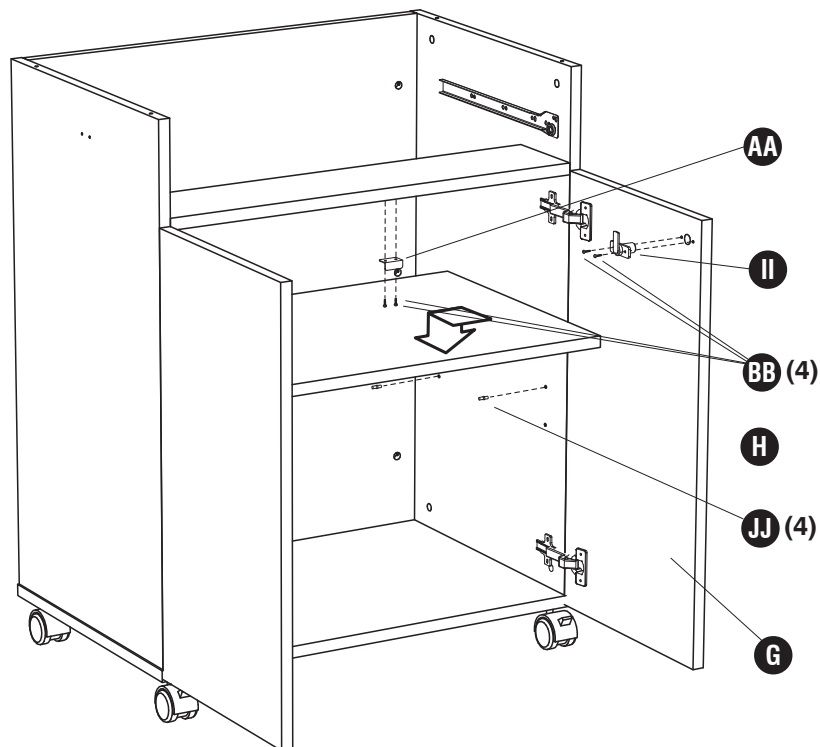

11 X (4) BB (20)

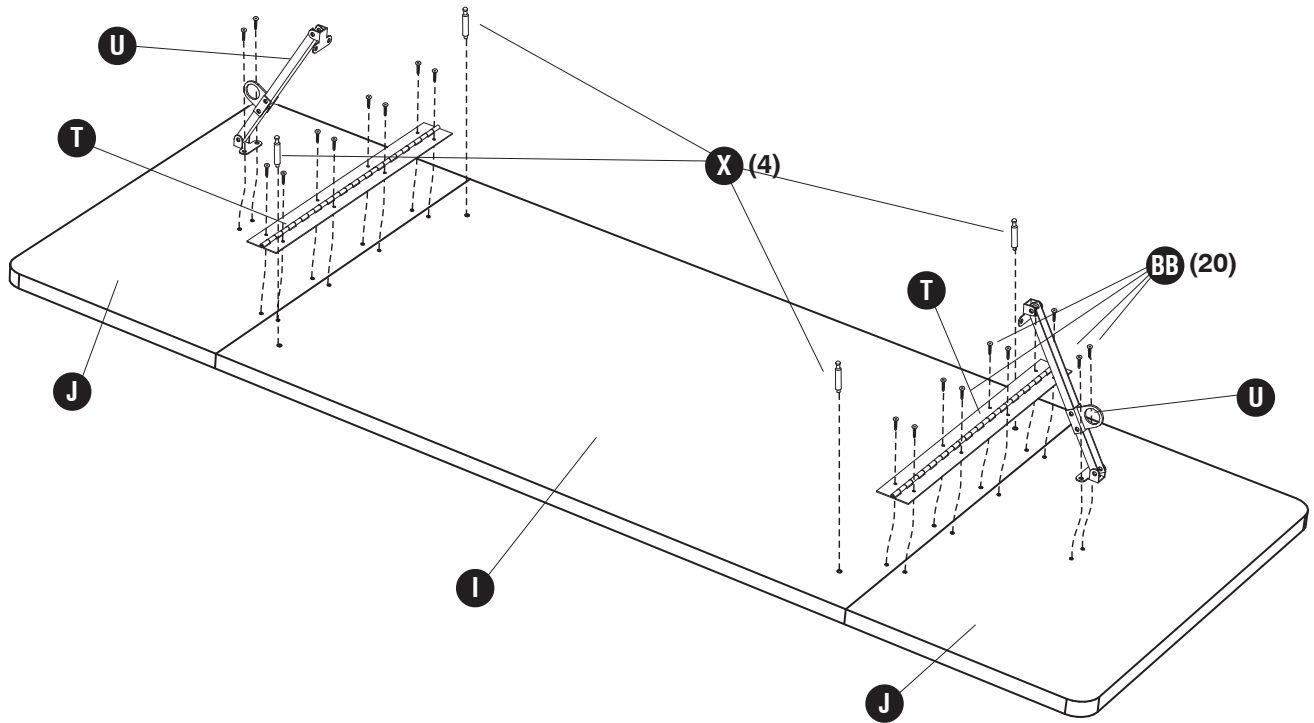

12 BB (4)

Two People Recommended.

On recommande que l'assemblage soit effectué par deux personnes.

Se recomienda dos personas para el ensamblaje.

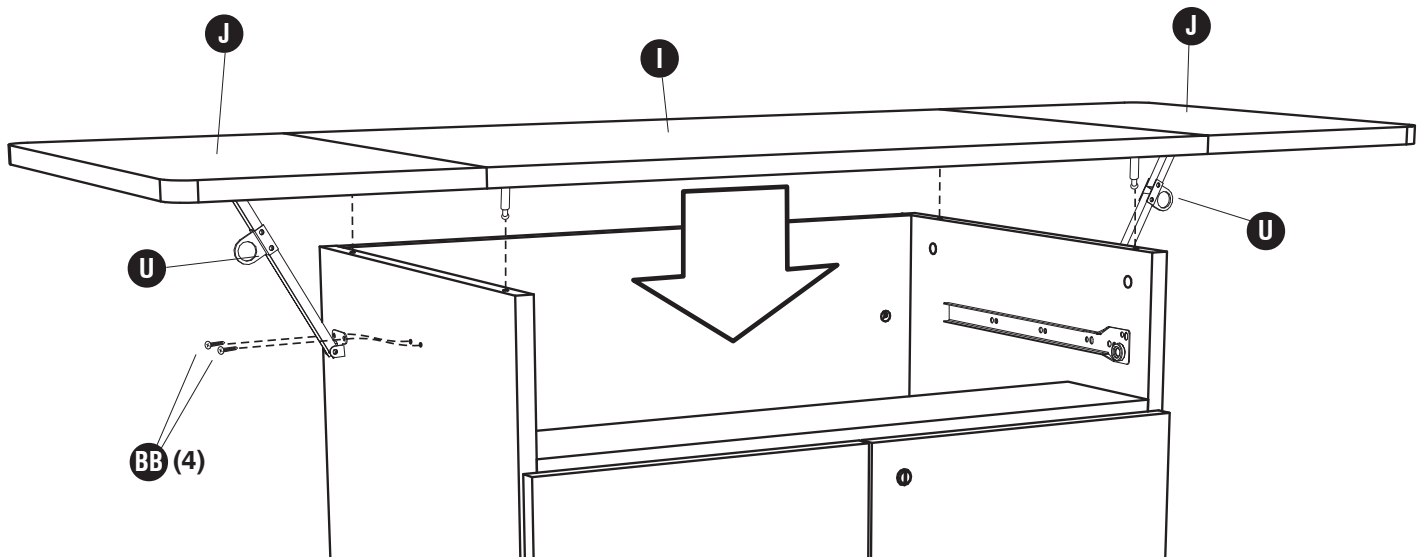

13 DD (4)

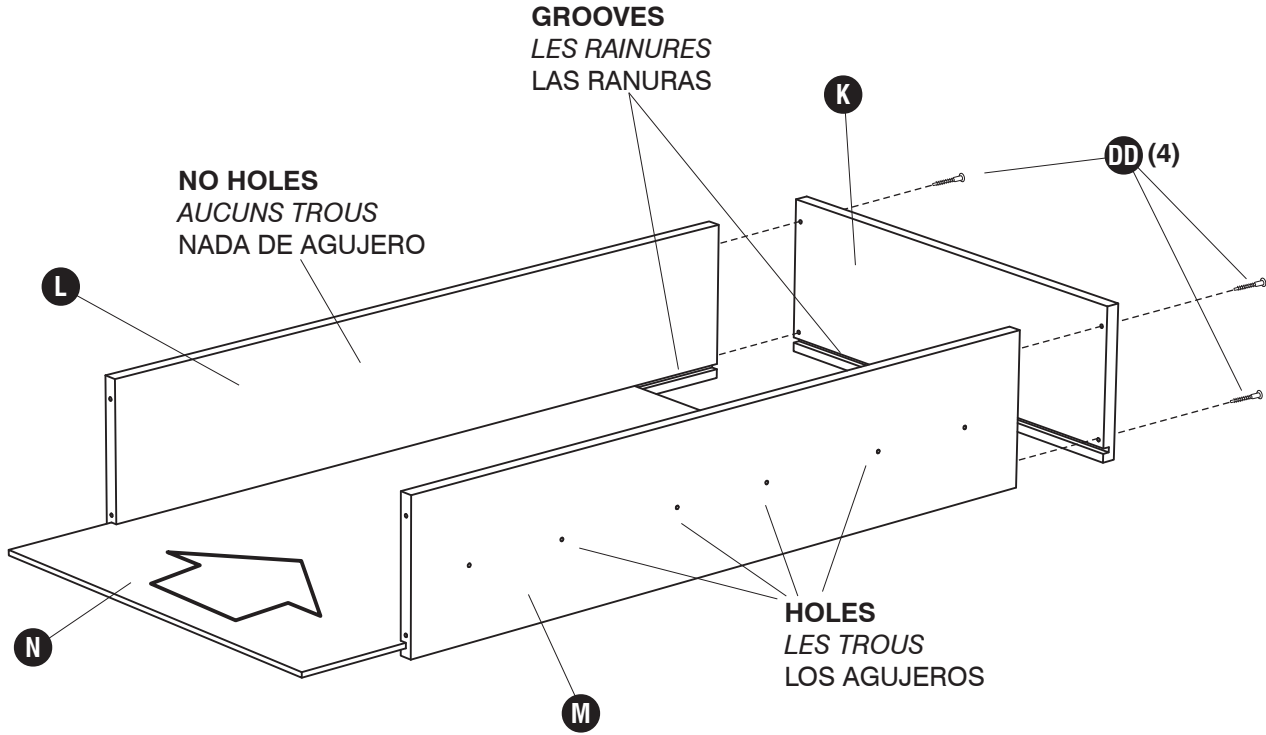

14 DD (4)

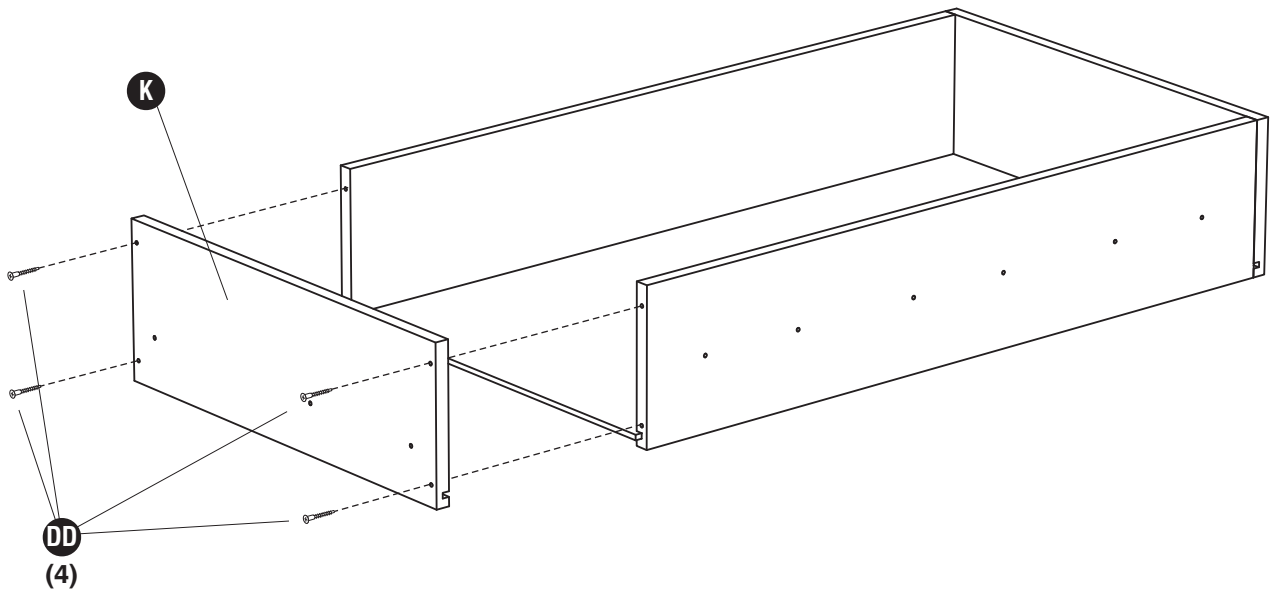

15 **BB** (6) **EE** (4) **FF** (2)

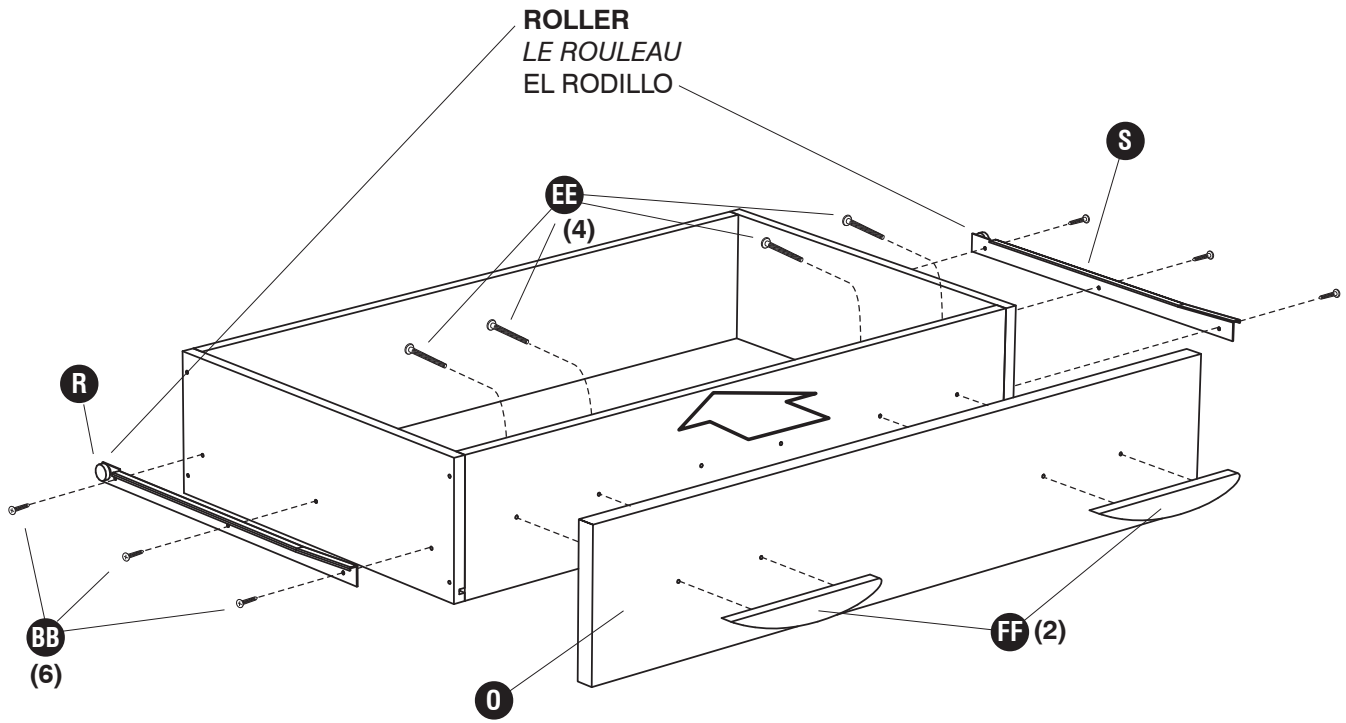

16

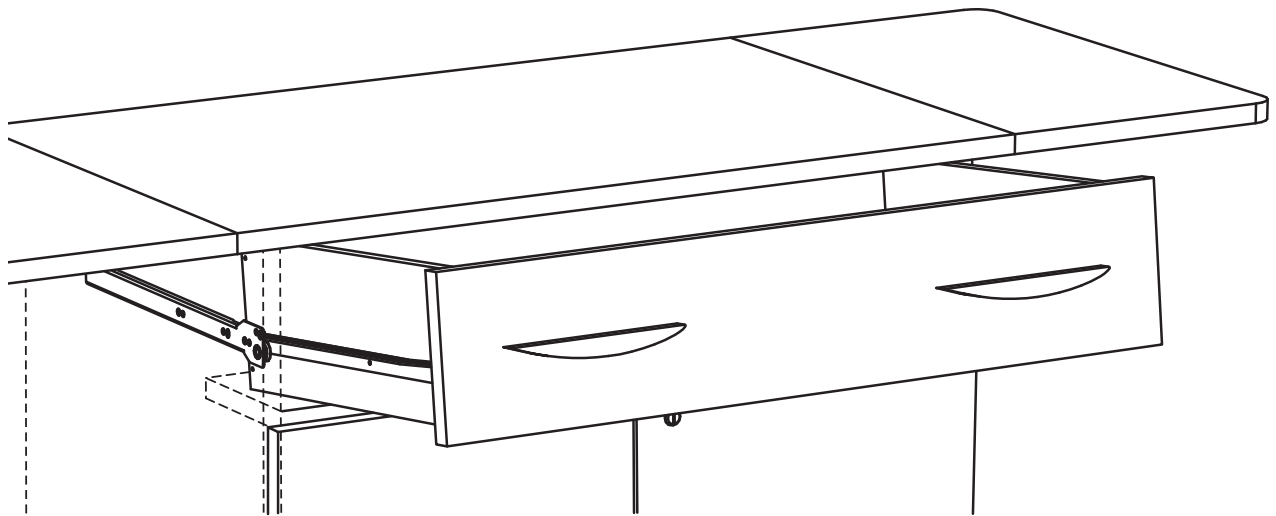

17 Optional:
Facultatif:
Opcional:

