

Assembly Instructions

Akro-Mils Easy Flow Gravity Hopper Dolly Model No. 30600DOLLY

Instrucciones de Ensamble
Akro-Mils Easy Flow Gravity Hopper Dolly
Ejemplar No. 30600DOLLY

Instructions d'assemblage
Akro-Mils Easy Flow Gravity Hopper Dolly
Le modele No. 30600DOLLY

Parts

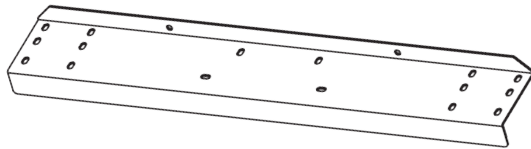

A x 2
R010824

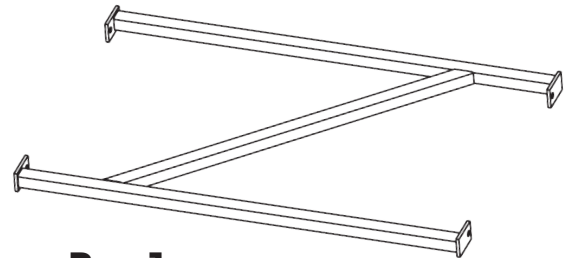

B x 1
R020377

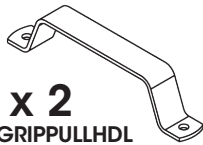

C x 2
RH.GRIPPULLHDL

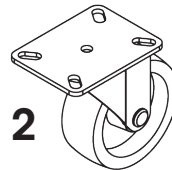

D¹ x 2
R4POS

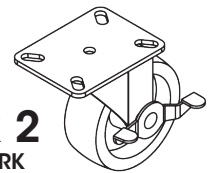

D² x 2
R4POSBRK



E x 20
RH.3125X.75CB
5/16 -18 x 3/4"



G x 24
RH.3125WFN
5/16 -18



J x 4
RH.25WFN
1/4 -20



F x 4
RH.3125 X.75CS
5/16 -18 x 3/4"



H x 4
RH.25X.50THS
1/4 -20 x 1/2"

Tools

Herramientas Outils



Screwdriver
Destornillador
Tournevis

Goggles
Gafas
Lunettes de
protection



Wrench
Llave
Clé à
ouverture fixe



Notice:

We recommend using a ratchet wrench and sockets or open end wrenches and a straight blade screwdriver.

Aviso:

Recomendamos utilizar una llave de trinquete y cubos, o una llave de boca y un destornillador plano.

Avis :

Nous recommandons d'utiliser une clé à rochet et des douilles ou des clés à fourche et un tournevis à lame plate.

RECOMMENDATION:

Assemble racks on corrugated carton to avoid damage to painted surfaces.

RECOMENDACION:

Ensamble los estantes sobre cartón corrugado para no dañar las superficies pintadas.

RECOMMANDATION :

Afin de ne pas endommager les surfaces peintes, assemblez les étagères sur du carton en papier ondulé.

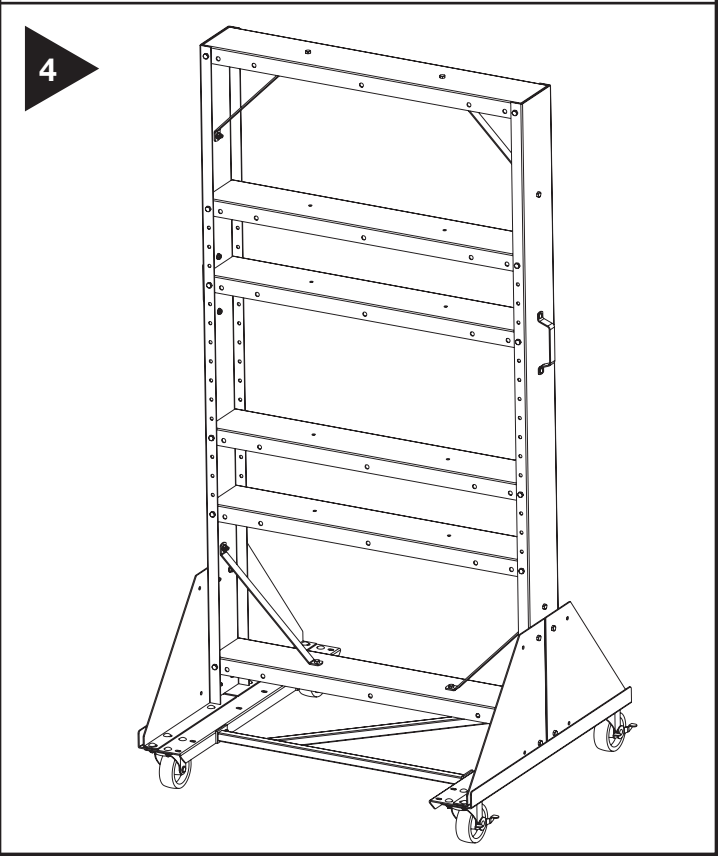
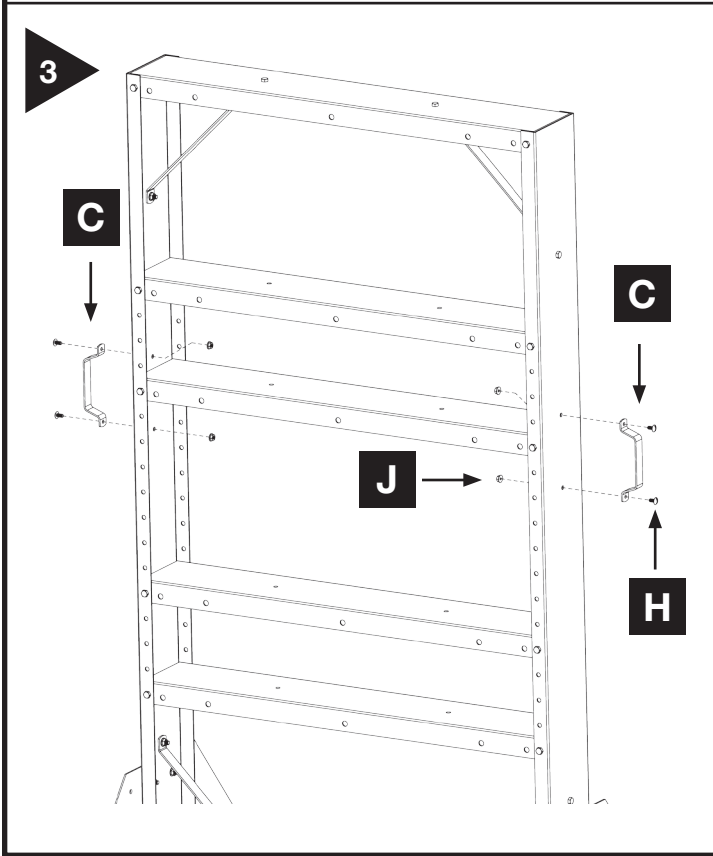
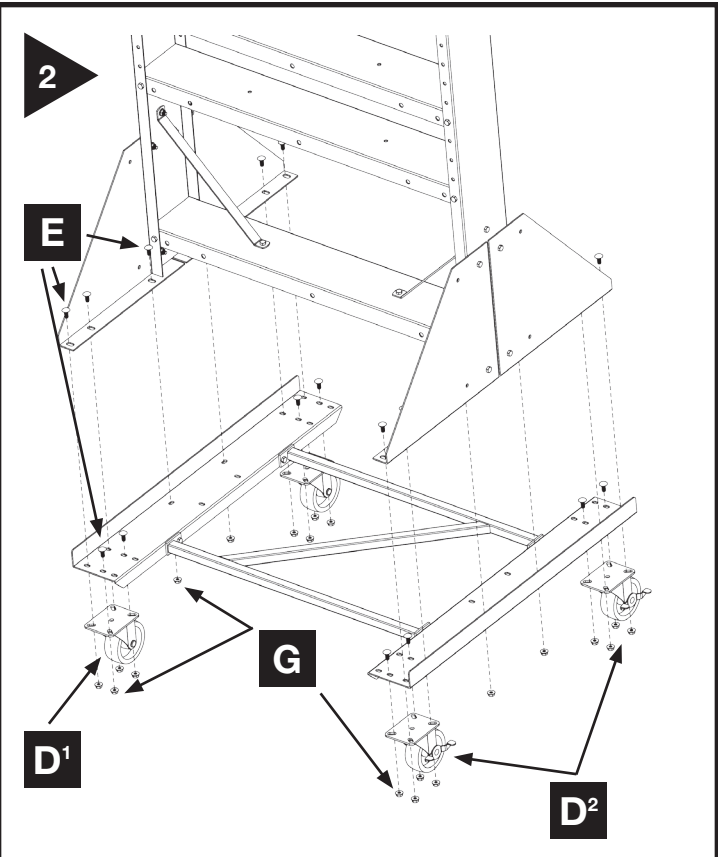
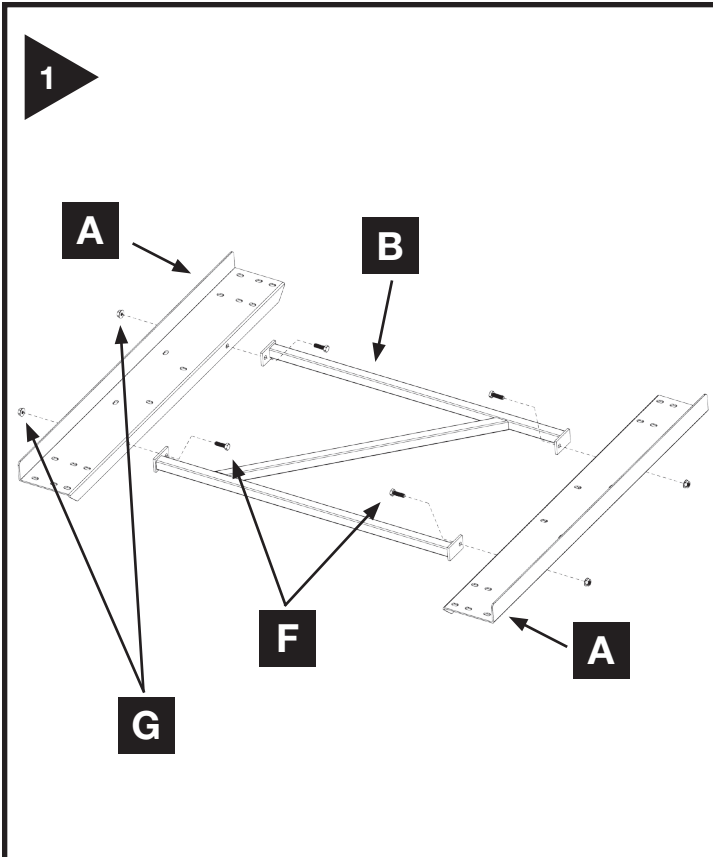

Akro-Mils • P.O. Box 989 • Akron, Ohio 44309 • 1-800-253-2467 • Fax: 330-761-6348 • www.akro-mils.com • e-mail: sales@akro-mils.com