

Surge Protection Made Simple™ for IEC Applications

IEC Class I Combined Lightning, Current and Surge Arresters for 230/400 Volt, 4-Pole TNS & TT Systems



Description

The Cooper Bussmann® IEC Class I 230 volt, four-pole, modular combined lightning, current and surge arresters feature local, *easyID*™ visual indication and optional remote contact signaling. The unique module locking system fixes the protection module to the base part. Modules can be easily replaced without tools by simply depressing the release buttons. Integrated mechanical coding between the base and protection module ensures against installing an incorrect replacement module.

230 Volt models are offered with MCOV ratings of 255 volts.

TNS System Arresters

The features of these four-pole devices are for use in TNS 230/400 volt systems ("4-0" circuit) against surges.

TT System Arrester

Provides a current arresting means between neutral conductor and protective conductor in TT 230/400 volt systems ("3+1" circuit) against surges.

Remote Signaling Contact

The three-pole terminal remote signaling contact versions have a floating changeover contact for use as a break or make contact, according to circuit concept.



BSPS4255TNS(R)
BSPS4255TT(R)



easyID™
Visual Status Indication



Remote Signal Contact Available



Dimensions - mm

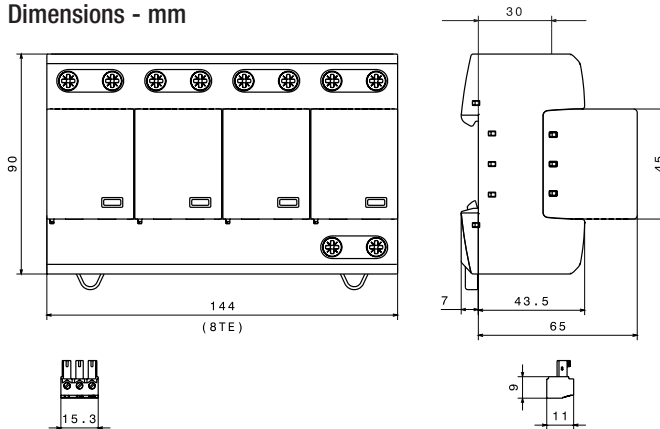

Shown with optional remote contact signaling

Circuit Diagrams

- Creepage Discharge Spark Gap
- Spark Gap Trigger

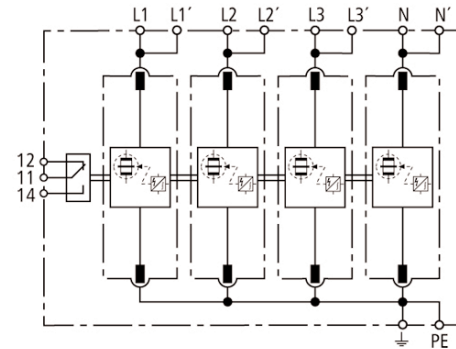

BSPS4255TNS(R)
Shown with optional remote contact signaling

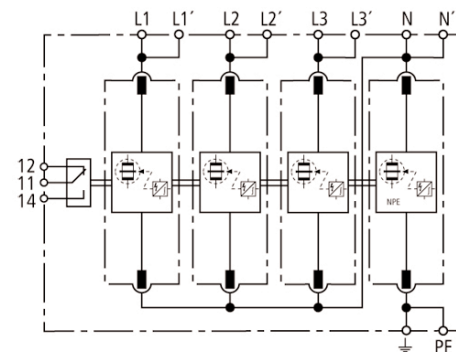

BSPS4255TT(R)
Shown with optional remote contact signaling

Ordering Information		
System Voltage/Poles		230/400V/4
Max. Continuous operating AC voltage (MCOV) [U _C]		255V
Catalog Numbers:	Without Remote Signaling	BSPS4255TNS
	With Remote Signaling	BSPS4255TNSR
Replacement Modules:	MOV technology	BPS255IEC
	Spark Gap technology	- -
		230/400V/4
		255V
		BSPS4255TT
		BSPS4255TTR
		BPS255IEC
		BPS100NPEIEC*
Specifications		
SPD according to EN 61643-11/... IEC 61643-1		Type 1/Class I
Energy-coordinated protection effect with regard to the terminal equipment		Type 1 + Type 2
Energy-coordinated protection effect with regard to the terminal equipment (≤ 5m)		Type 1 + Type 2 + Type 3
Nominal AC voltage [U _N]		230/400V
Lightning impulse current (10/350 μs) [L1+L2+L3+N-PE] [I _{total}]		100kA
Specific energy [L1+L2+L3+N-PE] [W/R]		2.50MJ/ohms
Lightning impulse current (10/350 μs) [L, N-PE] [I _{imp}]		25kA
TNS system specific energy [L,N-PE] [W/R]		156.25kJ/ohms
TT system specific energy [L-N]/[N-PE] [W/R]		156.25kJ/ohms/2.50kJ/ohms
Nominal discharge current (8/20 μs) [I _n]		25/100kA
Voltage protection level [L-PE]/[N-PE] [U _p]		≤ 1.5kV/≤ 1.5kV
TNS system follow current extinguishing capability AC [I _{ff}]		50kA rms
TT system follow current extinguishing capability AC [I _{ff}]		50kA rms/100A rms
Follow current limitation/Selectivity		No tripping of a 20A gL/gG fuse up to 50kA rms (prosp.)
Response time [t _A]		≤ 100 ns
Max. Backup fuse (L) up to I _k ≤ 50kA rms		315A gL/gG
Max. Backup fuse (L) for I _k > 50kA rms		200A gL/gG
Max. Backup fuse (L-L')		125A gL/gG
Temporary overvoltage (TOV) [L-N] [U _T]		440V/5 sec.
Temporary overvoltage (TOV) [N-PE] [U _T]		1200V/200mS
TOV characteristics		Withstand
Operating temperature range [parallel]/[continuity] [T _U]		-40°C to +80°C/-40°C to +60°C
Operating state/fault indication		green (good)/red (replace)
Number of ports		1
Cross-sectional area (L1, L1', L2, L2', L3, L3', N, N', PE, $\frac{\perp}{\perp}$) [min.]		10mm ² solid/flexible
Cross-sectional area (L1, L2, L3, N, PE) [max.]		50mm ² /1AWG stranded-35mm ² /2AWG flexible
Cross-sectional area (L1', L2', L3', N', $\frac{\perp}{\perp}$) [max.]		35mm ² /2AWG stranded-25mm ² /4AWG flexible
Mounting		35mm DIN Rail per EN 60715
Enclosure material		Thermoplastic, UL 94V0
Location category		Indoor
Degree of protection		IP20
Capacity		8 mods., DIN 43880
Agency Information		KEMA
Product Warranty		Five Years**
Remote Contact Signaling		
Remote Contact Signaling Type		Changeover Contact
AC Switching Capacity (Volts/Amps)		250V/0.1A
DC Switching Capacity (Volts/Amps)		250V/0.1A; 125V/0.2A; 75V/0.5A
Conductor Ratings and Cross-Sectional Area for Remote Contact Signal Terminals		60/75°C Max. 1.5mm ² /14AWG Solid/Flexible
Ordering Information		Order from Catalog Numbers Above

* N-PE Surge arrester for location between neutral conductor and protective conductor in TT systems.

** See Cooper Bussmann SPD Limited Warranty Statement (3A1502) for details at www.cooperbussmann.com/surge.

Recommended Cooper Bussmann NH DIN Size Back Up Fuses			
Size	NH Fuse Part Number	Size	NH Fuse Part Number
00	125NHG00B (max L-L)	02	125NHG02B (max L-L)
0	125NHG0B (max L-L)	02	200NHG02B (max L I _k >50kA)
01	125NHG01B (max L-L)	2	315NHG2B (max L ≤50kA)
1	200NHG1B (max L I _k >50kA)	03	315NHG03B (max L ≤50kA)

The only controlled copy of this Data Sheet is the electronic read-only version located on the Cooper Bussmann Network Drive. All other copies of this document are by definition uncontrolled. This bulletin is intended to clearly present comprehensive product data and provide technical information that will help the end user with design applications. Cooper Bussmann reserves the right, without notice, to change design or construction of any products and to discontinue or limit distribution of any products. Cooper Bussmann also reserves the right to change or update, without notice, any technical information contained in this bulletin. Once a product has been selected, it should be tested by the user in all possible applications.