

ERITECH[®]

Coordinated Facility Protection

Selecting Surge Protection



ERICO[®]

Introduction.....	3
The Need for Coordinated Protection	4-5
Selecting Surge Protection	6-7
A Guide to Common Power Distribution Systems	8-11
Data and Signal Line Protection	12-14
Surge Protection And Surge Ratings	15
Advanced Technologies – The ERICO Advantage	16
Glossary of Terminology.....	17-18

Electrical Power Protection

Panelboard Mount

Service Entrance Suppression	19-20
Transient Discriminating Service Entrance Suppressor	21-22
Transient Discriminating Panel Protection	23-31
Transient Discriminating MOVTEC Protection Module	32
Transient Discriminating MOVTEC.....	33

DIN Rail Mount Diverters

Triggered Spark Gap	34
Spark Gap Diverter	35
TDS Surge Diverter	36-40
TDS Surge Diverter – Photovoltaic.....	41
Dinline Surge Diverter.....	42-50

DIN Rail Mount Filters

Dinline Surge Filter	51
Transient Discriminating Filter	52-53

Surge Reductions Filters

TSG-SRF	54-55
---------------	-------

Data, Control, Signal Line Protection

Data & Signal Line Protection

Universal Transient Barrier.....	56-60
Remote Transmitter Protector	61
Loadcell Protector.....	62

Telecommunications

Subscriber Line / High Speed Data Line Protection.....	63
RJ11 Telephone Line Protection.....	64

Communication

Data Equipment Protection	65
Local Area Network Protection	66

Coaxial

Community Antenna and Closed Circuit Television Protection.....	67
Coaxial Surge Protection.....	68

Special Application Products

MWE - Outdoor Weatherproof Enclosures	69-72
Potential Equalization Clamp	73
DINLINE Decoupling Inductor/ DINLINE Alarm Relay & Surge Counter.....	74
MGA Tester	75



Introduction

By following the Six Point Plan of Protection, ERICO customers are able to implement the most effective solutions to individual lightning, grounding and surge problems while retaining an integrated protection philosophy.

Point 5 of the Six Point Plan advocates a coordinated approach to surge protection, where the first stage of defense is the installation of primary protection devices at the mains supply service entrance, followed by secondary protection at distribution branch panels and where necessary, at point-of-use applications.

Point 6 recognizes the need to provide effective surge protection on cables supplying telecommunications, signal and data management equipment.

The Six Point Plan of Protection from ERICO

- 1** Capture the lightning strike.
Capture the lightning strike to a known and preferred attachment point using a purpose-designed air terminal system.
- 2** Convey this energy to ground.
Conduct the energy to the ground via a purpose-designed downconductor.
- 3** Dissipate the energy into the grounding system.
Dissipate the energy into a low impedance grounding system.
- 4** Bond all ground points together.
Bond all ground points to eliminate ground loops and create an equipotential plane.
- 5** Protect incoming AC power feeders.
Protect equipment from surges and transients on incoming power lines to prevent equipment damage and costly operational downtime.
- 6** Protect low voltage data/telecommunications circuits.
Protect equipment from surges and transients on incoming telecommunications and signal lines to prevent equipment damage and costly operational downtime.

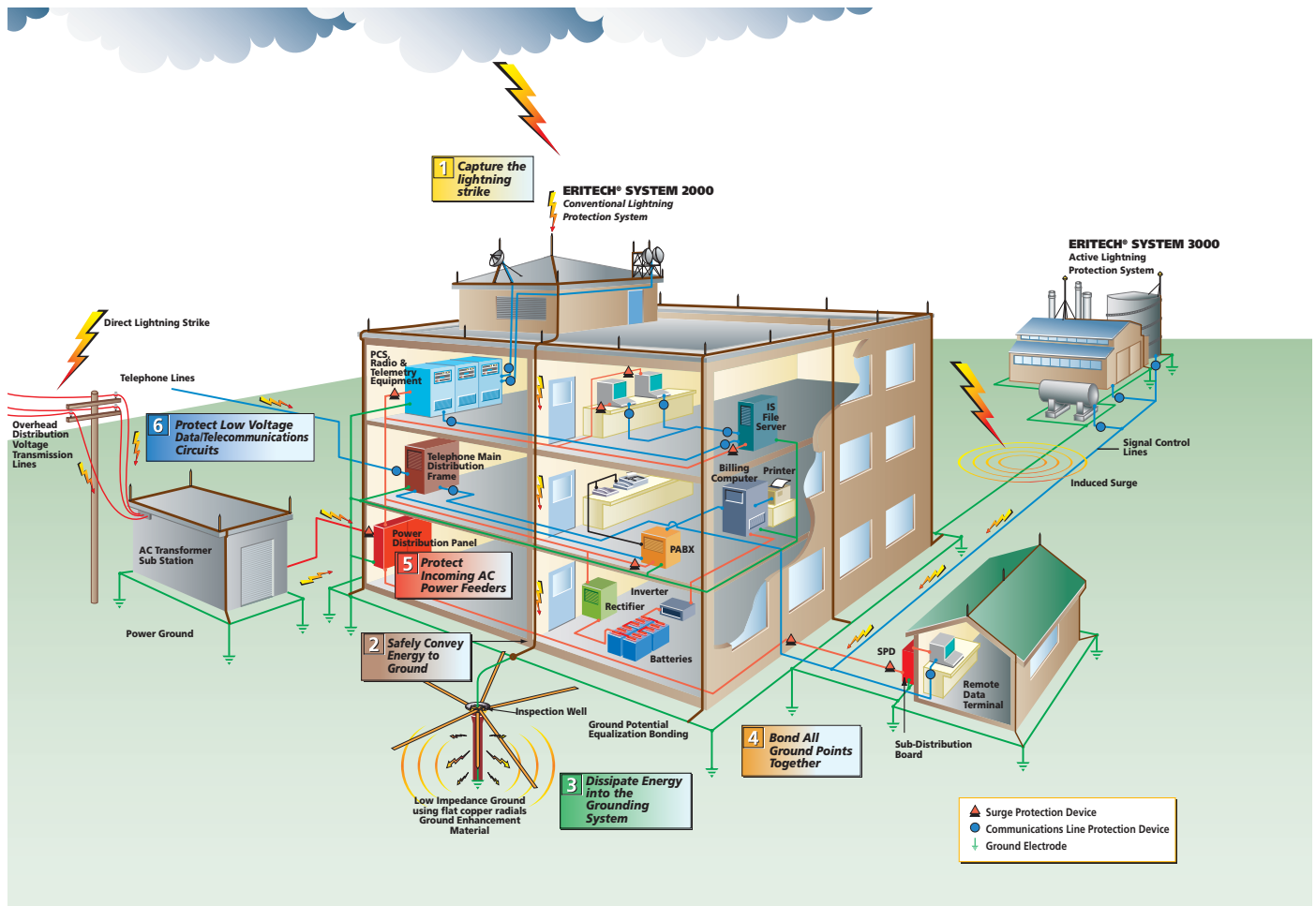

The Need for Coordinated Protection

Critical Factors

Critical factors need to be considered when determining the need for facility protection. Many factors can be determined by answering the following questions:

- What is the risk to personnel?
- What is the risk of equipment damage?
- What are the consequences of equipment failure?
- Is the equipment associated with an essential service?
- How will equipment failure affect overall facility operation and revenue generation?
- What are the legal implications of providing inadequate protection?

The statistical nature of lightning and the broad spectrum of energy delivered by a lightning flash, the problems created by various power generation and distribution systems, and the continued trend to more sensitive and specialized electronics, requires careful selection of available technologies if adequate protection is to be provided.

What are the costs of inadequate protection?

The costs that can result from inadequate protection are many and varied. The type of equipment within a facility will have a direct impact on the damage that can occur. Robust equipment, such as lighting and air-conditioning systems, are often able to withstand impulses as high as 1500 volts and are not as sensitive to the rapid rate-of-rise exhibited by the pre-clamped surge waveform as are electronics. These systems are often not critical to the continuing operation of the site and therefore usually do not require the premium level of protection that is essential for more sensitive equipment.

However, significant damage can occur, even to the more robust systems, as a result of lightning induced surges resulting within a radius of several kilometers, or from switching induced surges.

Costs can range from degradation of electrical or electronic systems to data loss, equipment destruction or injury to personnel. Some of these costs can appear relatively minor but the loss of an essential service or revenues associated with a facility or plant shut down can be enormous.

Sources of Transients and Surges

Although lightning is the most spectacular form of externally generated surges, it is only one source of over-voltage. Other sources include the switching of power circuits, the operation of electrical equipment by neighboring industries, the operation of power factor correction devices, and the switching and clearing of faults on transmission lines. It is important to note that lightning does not need to directly strike a power line for such damage to occur; a strike several hundred meters away can induce large damaging transients, even to underground cables.

It is estimated that 70 to 85% of all transients are generated internally within one's own facility by the switching of electrical loads such as lights, heating systems, motors and the operation of office equipment.

Modern industry is highly reliant on electronic equipment

and automation to increase productivity and safety. The economic benefits of such devices are well accepted. Computers are commonplace and microprocessor-based controllers are used in most manufacturing facilities. Microprocessors can also be found embedded in many industrial machines, security & fire alarms, time clocks and inventory tracking tools. Given the wide range of transient sources and the potential cost of disruption, the initial installed cost of surge protection can readily be justified for any facility.

As a guide, the cost of protection should be approximately 10% of the cost of the facility's economic risk.

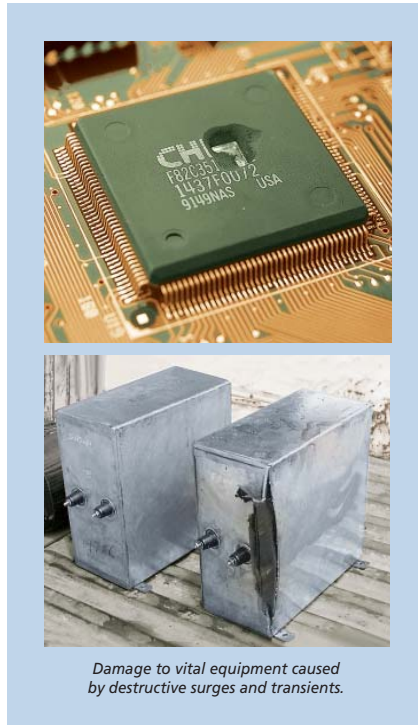

Damage to vital equipment caused by destructive surges and transients.

The Need for Coordinated Protection

Reliable protection of structures, industrial and commercial operations and personnel, demands a systematic and comprehensive approach to minimizing the threats caused by transient over-voltages. Grounding, bonding, lightning protection and surge protection all need to be considered for comprehensive facility electrical protection. Each of these are interdependent disciplines that need a holistic design approach to ensure the facility is not left with a vulnerable "blind spot". The investment in surge protection can be wasted if "blind spots" exist. For example, installing a surge protection device on the power supply to a programmable logic controller is of little value if the I/O lines are not also protected. In addition, an air terminal on the facility may capture the lightning energy but without a dependable ground system, this energy cannot be safely

dissipated. Equally, even the most expensive Surge Protection Devices (SPDs) are poor performers if a low impedance equipotential ground is not provided. These interdependent disciplines are best applied when looking at a total facility rather than at an individual piece of equipment or portion of the facility.

It is for these reasons that ERICO developed the Six Point Plan of Protection. The plan prompts the consideration of a coordinated approach to lightning protection, surge and transient protection and grounding, an approach that embraces all aspects of potential damage, from the more obvious direct strike to the more subtle mechanisms of differential earth potential rises and voltage induction at service entry points.

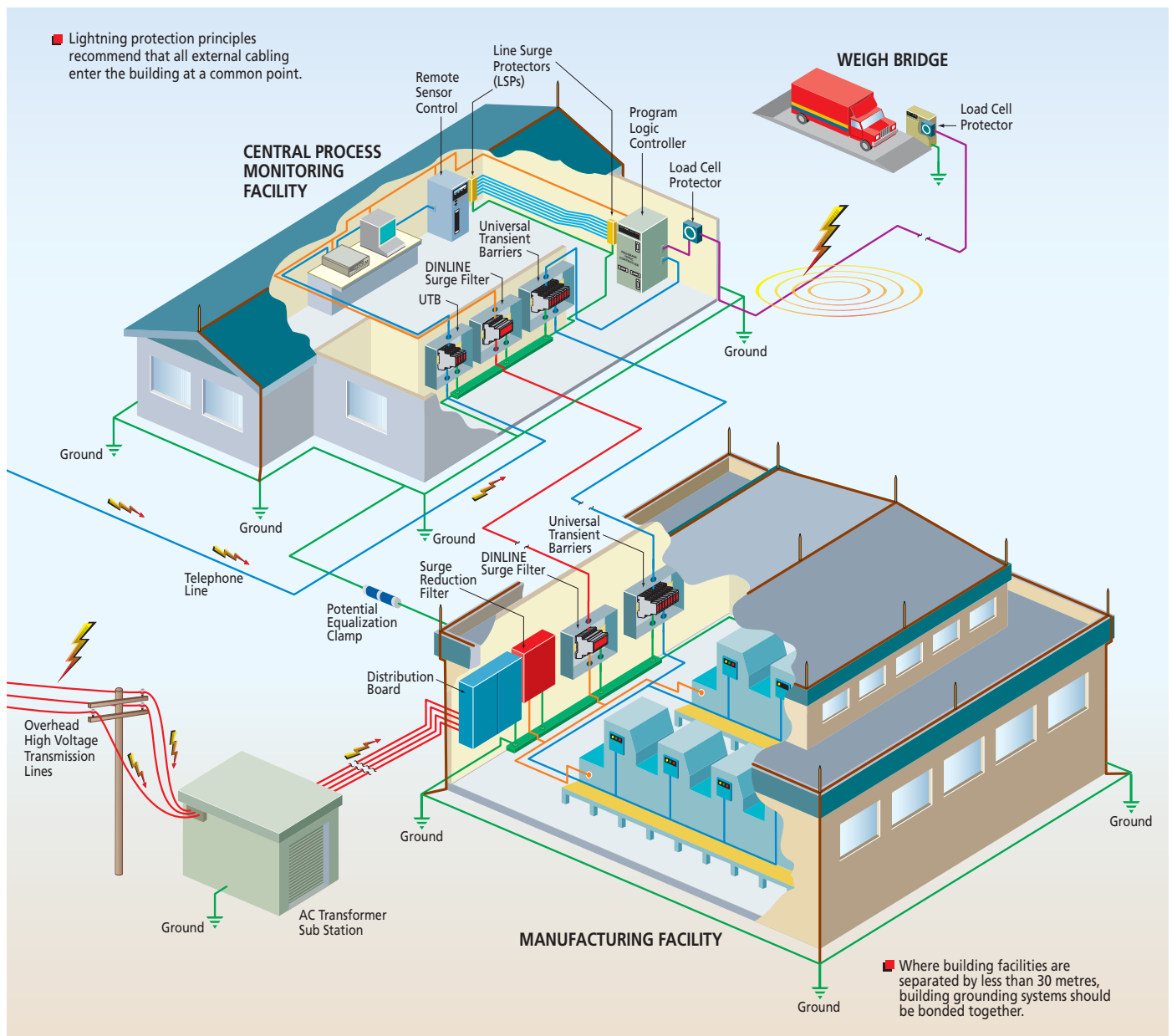

The Six Point Plan applied to a manufacturing facility. Surge and transient protection principles applied to a total facility rather than individual pieces of equipment.

Selecting Surge Protection

RECOMMENDED SURGE RATINGS (8/20 μ s)					
ANSI/IEEE C62.41			CAT C	CAT B	CAT A
IEC 61643 Test Class	I		I, II	II	III
VDE Classification	A		B	C	D
	POINT-OF-ENTRY HIGHLY EXPOSED OR CRITICALLY IMPORTANT SITES	POINT-OF-ENTRY EXPOSED OR RURAL SITES	POINT-OF-ENTRY INNER CITY SITES	SUB CIRCUITS OR NEAR TO POINT-OF-ENTRY	DISTRIBUTED CIRCUITS, POWER OUTLETS, CIRCUITS REMOTE FROM POINT-OF-ENTRY
EXPOSURE					
HIGH Ng >2	100kA	70kA	40kA	20kA	10kA
MED. Ng 0.5-2	65kA	40kA	20kA	20kA	5kA
LOW Ng <0.5	65kA	40kA	15kA	5kA	3kA

Ng = strikes/km²/year.

RECOMMENDED PRODUCTS					
PRODUCT SERIES	SES200				
	SES40 120/240				
	TDS MOVTEC & MPM				
	TDX200 / TDX300 / TDX400				
	TDX100				
	TDX50				
	TSG - SRF				
	TSG / SGD				
	DSD1150				
	TDS / DSD1100				
	DSD160 & DSD380				
	TDS / DSD140 & TDS / DSD340				
	TDS130				
	DSD110				
	TDF				
	DSF6A				



Selecting Surge Protection

Recommended Surge Ratings – A Comparison between IEC and IEEE® Recommendations

Competition between SPD manufacturers has seen ever-increasing surge ratings being offered to the market, to the point where surges of this magnitude are unlikely to ever occur in nature. A number of sources provide information on the statistical distribution of the current discharge of the direct lightning strike. Many studies have shown that peak lightning discharges above 100kA are likely to occur less than 5% of the time. Combined with the fact that most discharges do not strike the power line directly but are magnetically or capacitively coupled to it, and that even under a direct lightning discharge the energy will split in either direction and be attenuated by the distribution arresters and line losses, it is not difficult to determine that a smaller fraction of the initial lightning energy typically enters the facility in question.

ANSI/IEEE standard C62.41 has classified the “point-of-entry” environment as CAT. B/C. Under this classification the highest expected energy level is 10kA 8/20µs. In contrast, the IEC61312 and DIN VDE 0675 defines some differing guidelines. IEC 61000-5-6 and IEC 61312-1 describe protection zone concepts. This is similar in nature to the ANSI/IEEE C62.41 concept of Category A, B & C locations.

A “Zone” is where the lightning electromagnetic environment can be defined/controlled. The zones are characterized by significant changes of electromagnetic conditions at these boundaries. These will typically be building boundaries, or the point where protection is installed.

- LPZ O_A Zone subject to direct strikes
- LPZ O_B Zone not subjected to direct strikes, but un-attenuated electromagnetic fields may occur.
- LPZ 1 Zone not subjected to direct strikes and where currents in this zone are reduced compared to Zone O_B
- LPZ 2... If further reductions in current from LPZ 1 are achieved/required further zones can be created.

Actual surge ratings required in each of these zones is not exactly defined and is largely determined by some site-specific details. However, to assist with this the VDE0675 Part 6 standard defines the minimum class of product that can be applied to each of these Zones as shown below:

- Class A : Arrester for use in low-voltage overhead lines
- Class B : Arrester for lightning current equipotential bonding (must withstand 100kA 8/20µs or 10As charge, twice). Zones O_B to 1 (Main distribution Boards, Sub-Boards)
- Class C : Arrester for over-voltage protection (must have a nominal surge rating of at least 5kA 8/20µs) Zones 1 to 2 (mainly sub-boards or low exposure main boards)
- Class D : Arrester for portable use on socket-outlets (must have a nominal surge rating of at least 1.5kA 8/20µs)

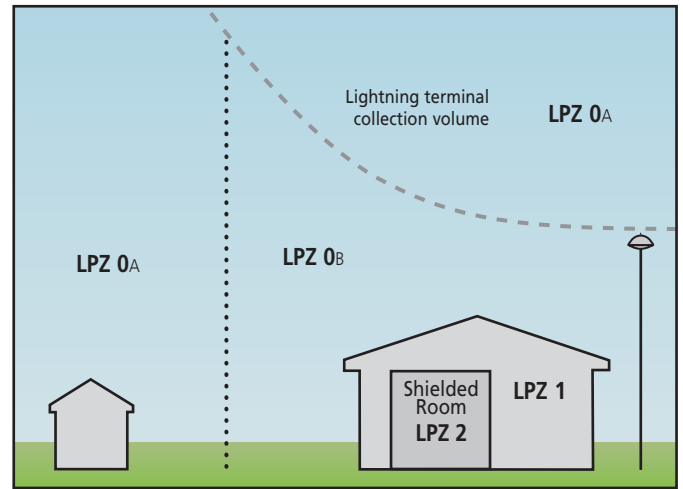

Protection zones defined by specific product application.

As it can be shown, protection equipment for power supply systems are classified as follows, according to its task →

- Lightning Current Arrester
- Over-voltage Arrester

Lightning current equipotential bonding arresters must be capable of conducting a portion of the lightning current without being destroyed. Over-voltage arresters are only used for limiting over-voltages at relatively smaller surge currents. The different “protection zones” assume the division of the initial lightning current, from zone 0 to higher zones. For zone 0, it is required for the user to select the lightning protection class, from I - IV : (i.e. these refer to maximum energy within a direct lightning strike).

Protection Level	Current Magnitude	% Exceeded
Level I	200kA (10/350µs)	~ 0.2%
Level II	150kA (10/350µs)	~ 1.5%
Level III - IV	100kA (10/350µs)	~ 3%

The above levels can be selected based on the statistical level of protection required. A lightning current of 200kA (10/350µs) can be expected for the Protection Level I. This lightning current is divided as follows in the most exposed sites:

- 50% (100kA, 10/350µs) discharges via the ground system.
- 50% (100kA, 10/350µs) flows into the supply systems connected to it, via the three phase equipotential bonding lightning arresters.

On the other hand IEEE has adopted a Scenario II event, in which the building lightning protection system is subjected to a direct strike and the energy level sustained by the equipotential bonding surge arrester(s) is taken to be 10kA (10/350µs) or approximately 100kA 8/20µs as a worst case.

If we adopt IEC or DIN VDE Standard and assume a level of III-IV lightning protection system, each equipotential bonding surge arrester connected to a three phase, four wire, power system is assumed to experience a 12.5 kA (10/350µs) energy level at the Zone 0 interface due to lightning current sharing.

A Guide to Common Power Distribution Systems

Throughout the world a number of different power distribution systems are used. This guide identifies the more common of these systems. The individual product specification tables detail system suitability.

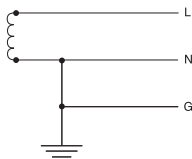
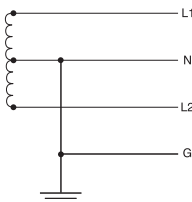
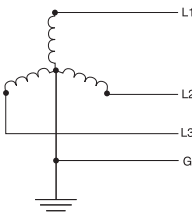
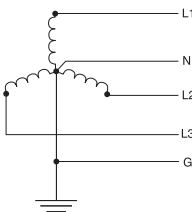
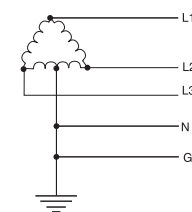
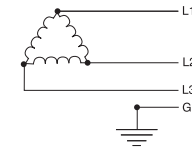
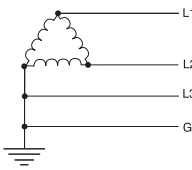
Description	Source Configuration	Typical Supply Voltages	
Single Phase 1Ph, 2W+G		110V 120V 220V 240V	(L-N)
Single Phase 1Ph, 3W+G Also known as Split phase or Edison system		120/240V	(L-N/L-L)
Three Phase WYE without neutral 3Ph Y, 3W+G		480V	(L-L)
Three Phase WYE with neutral 3Ph Y, 4W+G		120/208V 220/380V 230/400V 240/415V 277/480V 347/600V	(L-N/L-L)
Delta High leg 3Ph Δ, 4W+G		120/240V	(L-N/L-L)
Delta Ungrounded 3Ph Δ, 3W+G		240V 480V	(L-L)
Delta Grounded corner 3Ph Δ, 3W+G		240V 480V	(L-L)



A Guide to Common Power Distribution Systems

The IEC® 60364 series of standards characterizes low-voltage distribution systems by their grounding method and the arrangement of the neutral and protective earth conductors. The selection of SPDs must consider among other issues, the level of over-voltage that may temporarily occur within the distribution system due to ground faults. IEC 61643-12 details the temporary over-voltages that may occur during fault conditions for these systems. To conform with European wiring rules an SPD with a U_c rating equal to, or greater than, this

value should be selected. Effective protection does not require SPD's to be installed in all the modes detailed. The following diagrams provide guidance on the selection and installation of SPDs on the more common distribution systems. While three phase WYE systems are shown, similar logic can be applied to single phase, delta and other configuration sources.

U_o = Line to neutral voltage of the system

U_n = Nominal country specific system voltage (typically $U_o \times 1.10$)

TN-C System

In this, the neutral and protective earth conductor combine in a single conductor throughout the system. All exposed-conductive-parts are connected to the PEN conductor.

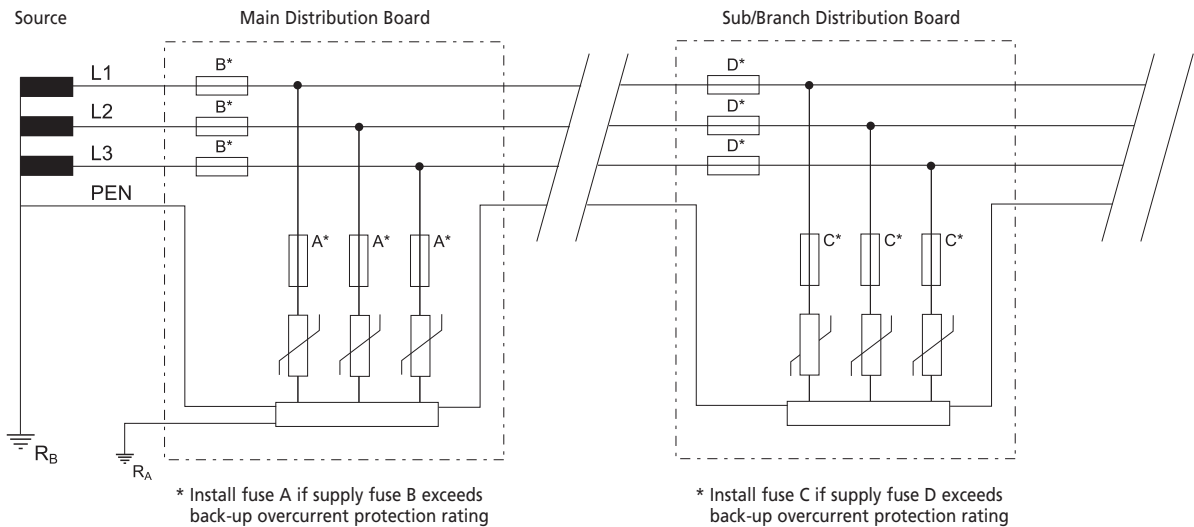

TN-S System

In this, a separate neutral and protective earth conductor are run throughout. The protective PE conductor can be the metallic sheath of the power distribution cable or a separate conductor. All exposed-conductive-parts of the installation are connected to this PE conductor.

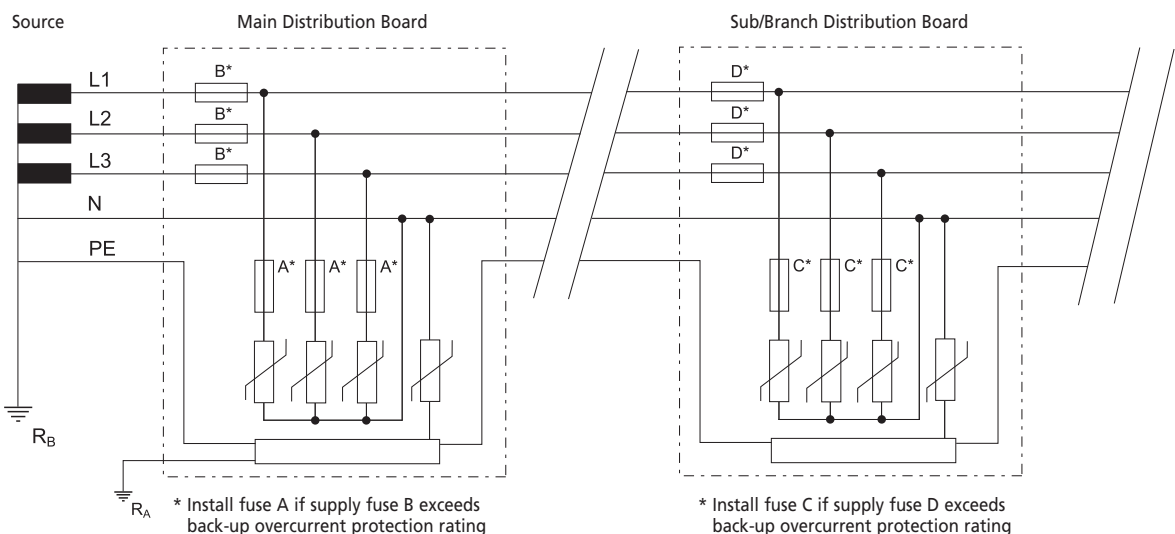

SPDs shown connected L-N and N-PE.
May also be connected L-PE and N-PE.

A Guide to Common Power Distribution Systems

TN-C-S System

In this, a separate neutral and protective earth combine in a single PEN conductor. This system is also known as a Multiple Earthed Neutral (MEN) system and the protective conductor is referred to as the Combined Neutral Earth (CNE) conductor. The supply PEN conductor is earthed at a number of points throughout the network and generally as close to the consumer's point-of-entry as possible. All exposed-conductive-parts are connected to the CNE conductor.

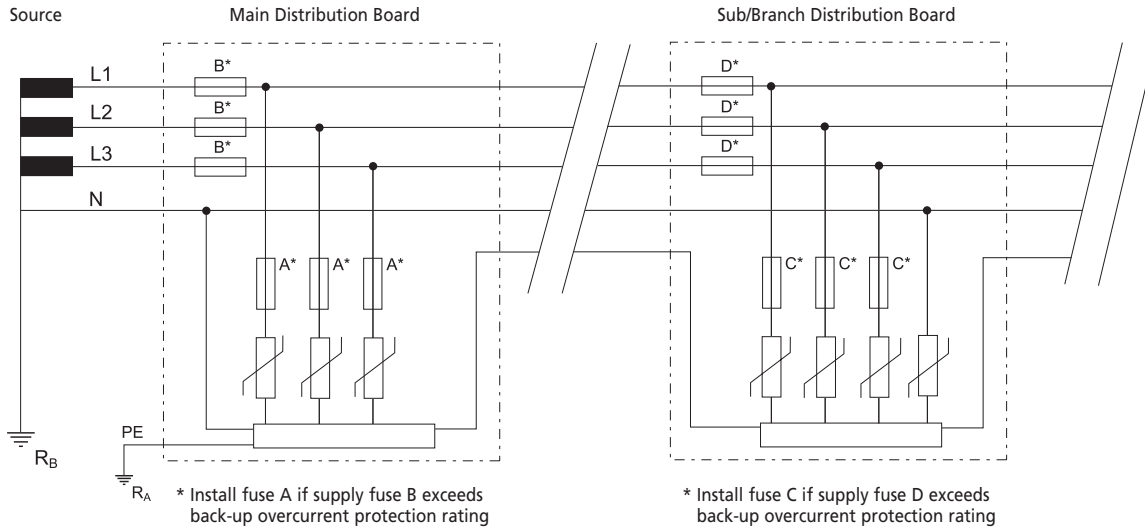

SPDs shown connected L-PE and N-PE.
May also be connected L-N and N-PE.

TT System

A system having one point of the source of energy earthed and the exposed-conductive-parts of the installation connected to independent earthed electrodes.

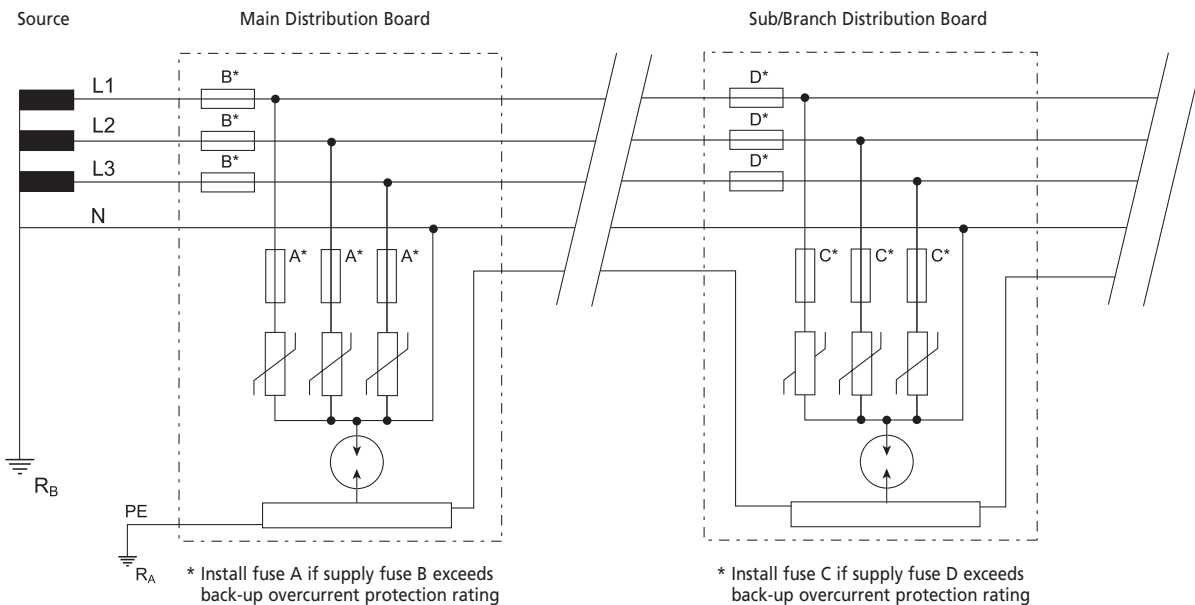

A Guide to Common Power Distribution Systems

IT System

A system having no direct connection between live parts and earth but all exposed-conductive-parts of the installation being connected to independent earthed electrodes.

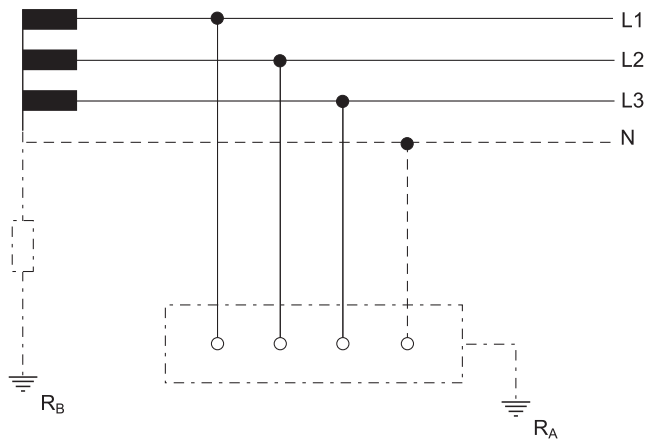

Distribution Network Configuration

	TN-C	TN-S TN-C-S	TT	IT with neutral conductor	IT without neutral conductor
Between					
Phase (line) and Neutral Conductor	X	$1.45 U_o$	$1.45 U_o$	$1.45 U_o$	X
Each Phase (line) Conductor and PE	X	$1.45 U_o$	$\sqrt{3} U_o$	$\sqrt{3} U_o$	$\sqrt{3} U_o$
Neutral Conductor and PE	X	U_o	U_o	U_o	U_o
Each Phase (line) Conductor and PEN	$1.45 U_o$	X	X	X	X

SPD U_c Selection:
 U_o = Voltage between phase (line) and neutral conductor
 X = Not applied

SPD selection must consider the level of over-voltage that may occur within the distribution system due to ground faults. The above IEC® table shows over-voltages that may occur during fault conditions for the various systems. An SPD with a U_c equal or greater than this value should be selected.

Metal Oxide Varistors (MOVs)

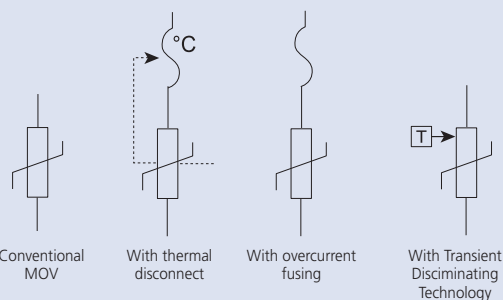

Gas Discharge Tubes (GDTs)

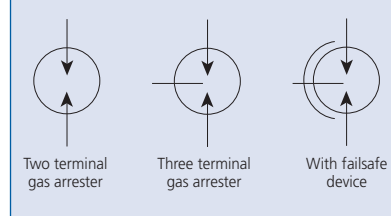

Other Symbols

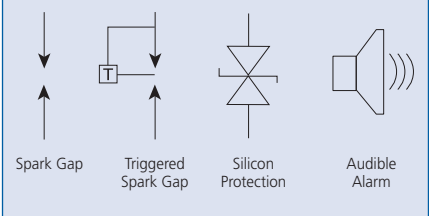

Data and Signal Line Protection

How to select surge protection for data, signalling and control circuits

Knowing where to install surge protection can be difficult. To ensure cost-effective protection is provided for data, signalling and control circuits, two issues need to be considered:

- Where should the SPDs be installed?
- What type of SPD is appropriate for each circuit type and location?

Where should the SPD(s) be installed?

Communications devices are at risk from transients being induced onto the interconnecting signal lines. The use of surge protection barriers, installed at either end of the lines, provides cost effective protection. Communication or signal lines that enter or exit the building pose the highest risk. In such circumstances, protection devices should be installed at the point-of-entry or at the equipment termination itself. Internal wiring which extends more than 10 to 15m should also be protected. Twisting or shielding of cables provides a level of protection, however this should not be regarded as sufficient for the sensitive interfaces that characterize today's communication devices.

How to select an SPD for a given location

Five parameters must be considered to ensure that surge protection devices for use on data, signalling or control circuits are effective and do not adversely affect operation of the circuit.

- 1) SPDs are designed to clamp the excess transient voltage to safe levels sustainable by the equipment, yet should not interfere with the normal signalling voltages. As a guide, the SPD clamping voltage should be selected to be approximately 20% higher than peak working voltage of the circuit.
- 2) The line current rating of the SPD should be sufficient to handle the maximum expected signalling current.
- 3) The SPD bandwidth should be sufficient to allow correct operation of the system without adverse attenuation. This ensures that the attenuation of the SPD at the nominal operating frequency of the system does not exceed the stated limit. For most SPDs, frequency attenuation data or a maximum recommended baud rate is generally specified.
- 4) The connection termination, mounting method, number of lines to be protected and other physical aspects must be considered.
- 5) The SPD surge rating should be appropriate for the intended location. For circuits internal to the building, surge ratings of 1-5kA are generally sufficient. For the protection of circuits that connect to exposed lines entering or exiting the facility, 10-20kA is recommended. Alternatively a protocol or standard may be specified that defines the above parameters. All UTB products are rated 20kA for higher exposure areas.

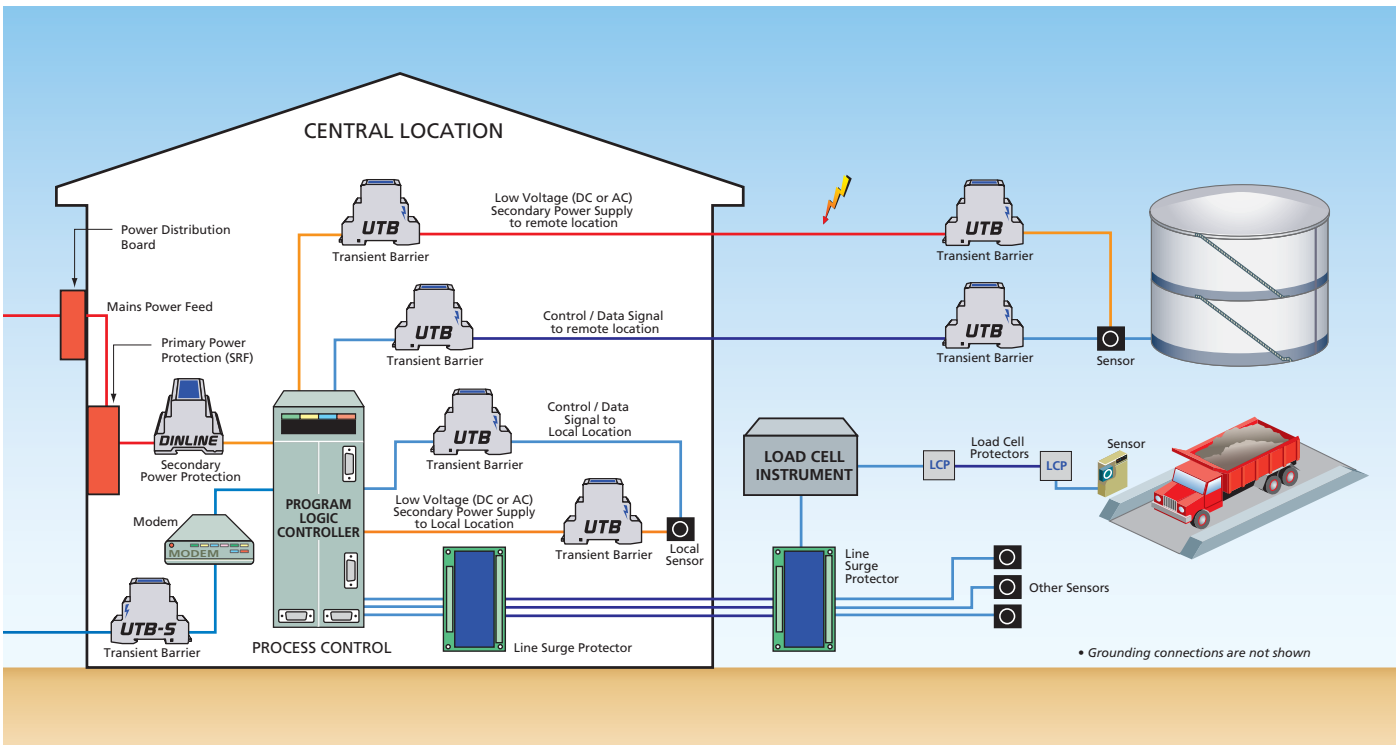

Data and Signal Line Protection

Sample Applications

2-Wire Isolated Ground Transducers/Sensors

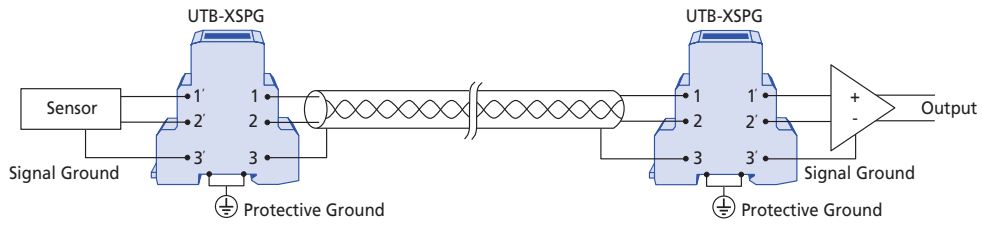

2-Wire Sensors

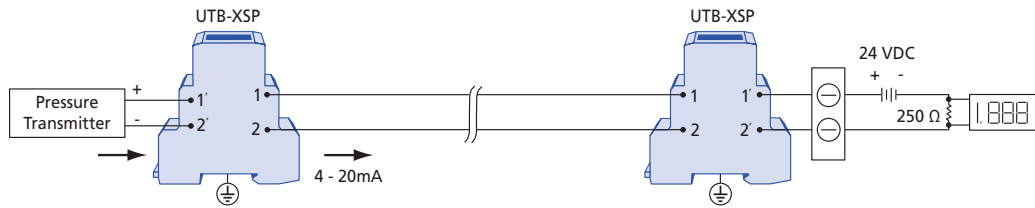

Powered Sensor Protection

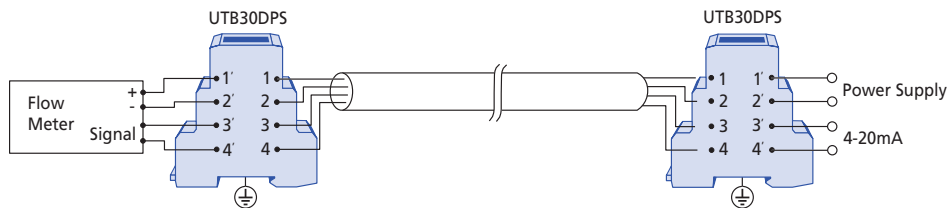

Multiple Sensor or up to 4-Wire Sensor

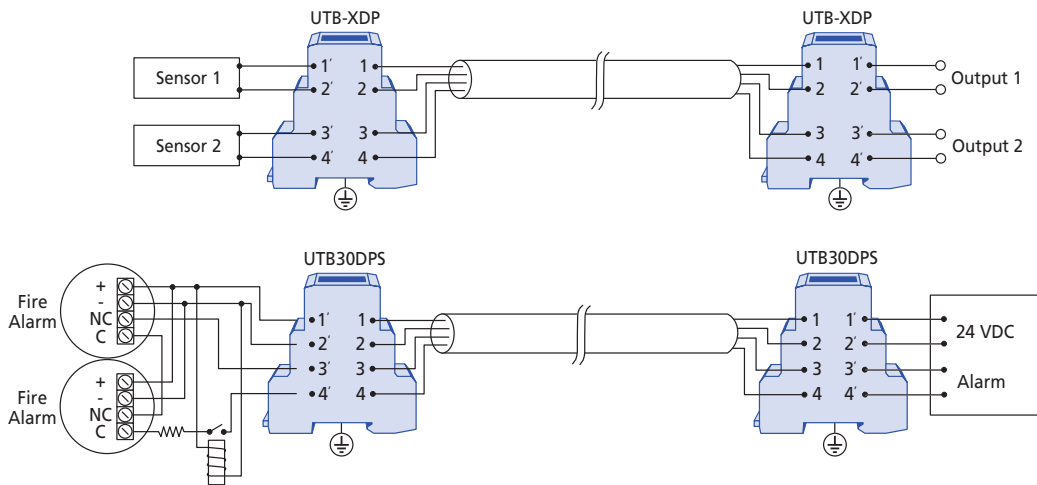

Protecting Sensors in Hazardous Locations

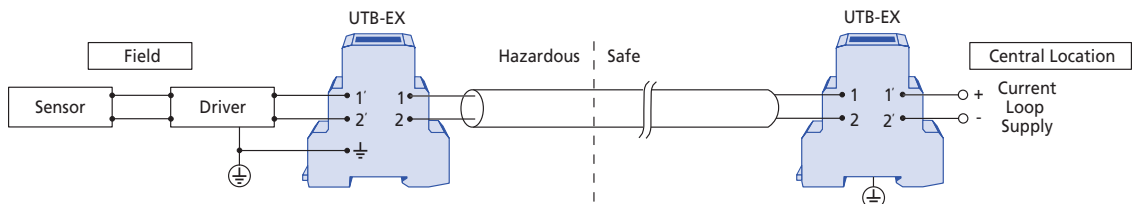

Data and Signal Line Protection

Guide to Data and Signaling Circuits

The selection of an SPD for communication and signalling circuits requires knowledge of the:

- 1) Maximum Continuous Operating Voltage (U_c)
- 2) Maximum line current (I_L)
- 3) Frequency
- 4) Termination (connector type and/or impedance)

Where a protocol is known, this often eliminates the need to verify product selection criteria 1-3, and occasionally 4. A number of different SPDs often meet the requirements as defined by the protocol, so the final choice of which SPD to use is often determined by its type of physical connection, number of lines to be protected, or its surge rating. Some protocols do not define the actual connector or pin configuration, and in some cases, not all lines defined by the protocol will be used. Please refer to the documentation provided with the equipment requiring protection to ensure the proposed protection modes are adequate and that the SPD's characteristics will not interfere with normal system operation.

Protocol/Standard	Description	Applicable SPD Series
RS-232 (V.24)	Unbalanced, bi-directional communication circuit. Although standard allows +/- 25 V signaling, use of more than +/- 12 V is uncommon	UTB 15 SP ⁽¹⁾ , UTB 15DP ⁽²⁾ UTB 5 ⁽¹⁾
RS-422 (V.11)	Industrial version of RS-232. 0-5 V balanced signaling	UTB 5 ⁽¹⁾
RS-423	Similar to RS-232 but +/- 5 V signaling used	UTB 5 ⁽¹⁾
RS-485	Similar to RS-422 but allows multiple devices to communicate. DB-9 connector is common	UTB 5 ⁽¹⁾
Ethernet	Ethernet is the term used to describe a family of communication protocols.	LAN RJ45 Series
Cat 4	* 10BaseT is a 10 MHz system using twisted pair of coax cables	
Cat 5	* 100BaseT is a 100 MHz system using twisted pair cables	
10BaseT	Cat 4 is a cable specification that allows operation up to 10BaseT,	
100BaseT	while Cat 5 allows operation up to 100BaseT frequencies.	
Telephone Lines		UTB SA ⁽²⁾ , UTB TA ⁽²⁾
4-20 mA current loop (with HART)	Common industrial communications protocol used to interface with transducers etc	UTB xDP, UTB 30DPS, UTB xSP
Binary Signals		UTB xSP ⁽¹⁾ , UTB xDP ⁽¹⁾
Bitbus (IEEE 1118)	Digital communications network based on RS-485 and SDLC allowing communication between PLCs and controllers	UTB 5 ⁽¹⁾
CAN-Bus (data signal line)	Differential serial communications protocol defined in ISO 11898 standard	
DeviceNet (data signal line)	Communication protocol used to connect industrial devices such as limit switches, motor starters to PLCs and controllers	
M-Bus	Communication protocol for networking and remote reading of heat, gas, water, and energy meters	UTB 60 ⁽¹⁾
Ex (I) - HART, 4-20 mA circuit, measurement circuits	Hazardous locations	UTB15 Ex , UTB30 Ex
Profibus - PA	Process field bus - process automation. Ideal for explosion - hazardous areas	UTB30 Ex
Strain gauge / Load cells	As used in weigh bridges etc.	LCP01A
ASDL	Asymmetric Digital Subscriber Line. Protocol for data communication over copper telephone lines. Uses single copper wire pair.	UTB TA ⁽²⁾ , UTB SA ⁽²⁾
HDSL	High bit rate Digital Subscriber Line. Protocol for data communication over copper telephone lines. Uses two copper wire pairs.	
ISDN	Integrated Service Digital Network. Protocol for voice and data over copper telephone lines	

(1) The number of UTB's required is dependent on the number of wires being used in the signalling circuit. UTBs are designed for balanced circuits and each UTB will protect one pair of wires. The UTB can also be used to protect two unbalanced circuits.

(2) The UBT TA is rated to 500 A 8/20 us and intended to meet US NEC requirements. The UTB SA are rated to 20 kA 8/20 μs and specifically designed and approved for use on the Australian telecommunication network.



Surge Protection And Surge Ratings

The stress, which an SPD will experience under surge conditions, is a function of many complex and interrelated parameters. These include:

- Location of the SPD(s) within the structure – are they located at the main distribution board or within the facility at secondary board, or even in front of the end-user equipment?
- Method of coupling the lightning strike to the facility – for example, is this via a direct strike to the structure's LPS, or via induction onto building wiring due to a nearby strike?
- Distribution of lightning currents within the structure – for example, what portion of the lightning current enters the earthing system and what remaining portion seeks a path to remote grounds via the power distribution system and equipotential bonding SPDs?
- Type of power distribution system – the distribution of lightning current on a power distribution system is strongly influenced by the grounding practice for the neutral conductor. For example, in the TN-C system with its multiple earthed neutral, a more direct and lower impedance path to ground is provided for lightning currents than in a TT system.
- Additional conductive services connected to the facility – these will carry a portion of the direct lightning current and therefore reduce the portion which flows through the power distribution system via the lightning equipotential bonding SPD.
- Type of waveshape – it is not possible to simply consider the peak current which the SPD will have to conduct, one also has to consider the waveshape of this surge. It is also not possible to simply equate the areas under the current-time curves (also referred to as the action integral) for SPDs under different waveshapes.

Many attempts have been made to quantify the electrical environment and "threat level" which an SPD will experience at different locations within a facility. The IEC standard on lightning protection, IEC 62305-4 "Protection against lightning - Part 4: Electrical and electronic systems within structures" has sought to address this issue by considering the highest surge magnitude which may be presented to an SPD based on the lightning protection level (LPL) being considered. For example, this standard postulates that under a LPL I the magnitude of a direct strike to the structure's LPS may be as high as 200 kA 10/350. While this level is possible, its statistical probability of occurrence is approximately 1%. In other words, 99% of discharges will be less than this postulated 200 kA peak current level.

An assumption is made that 50% of this current is conducted via the building's earthing system, and 50% returns via the equipotential bonding SPDs connected to

a three wire plus neutral power distribution system. It is also assumed that no additional conductive service exists. This implies that the portion of the initial 200 kA discharge experienced by each SPD is 25 kA.

Simplified assumptions of current dispersion are useful in considering the possible threat level, which the SPD(s) may experience, but it is important to keep in context the assumptions being made. In the example above, a lightning discharge of 200 kA has been considered. It follows that the threat level to the equipotential bonding SPDs will be less than 25 kA for 99% of the time. In addition, it has been assumed that the waveshape of this current component through the SPD(s) will be of the same waveshape as the initial discharge, namely 10/350, while in reality the waveshape have been altered by the impedance of building wiring, etc.

Many standards have sought to base their considerations on field experience collected overtime. For example, the IEEE® guide to the environment C62.41.1 and the recommended practice C62.41.2 present two scenarios of lightning discharge and different exposure levels under each of these depending on the location where the SPD is installed. In this standard, Scenario II depicts a direct strike to the structure, while Scenario I depicts a nearby strike and the subsequent conducted current into a structure via power and data lines. The highest surge exposure considered feasible to an SPD installed at the service entrance to a facility under Scenario I is 10 kA 8/20, while under Scenario II it is considered to be 10 kA 10/350 (exposure Level 3).

From the above, it is apparent that the selection of the appropriate surge rating for an SPD depends on many complex and interconnected parameters. When addressing such complexities, one needs to keep in mind that one of the more important parameters in selecting an SPD is its limiting voltage performance during the expected surge event, and not the energy withstand which it can handle.

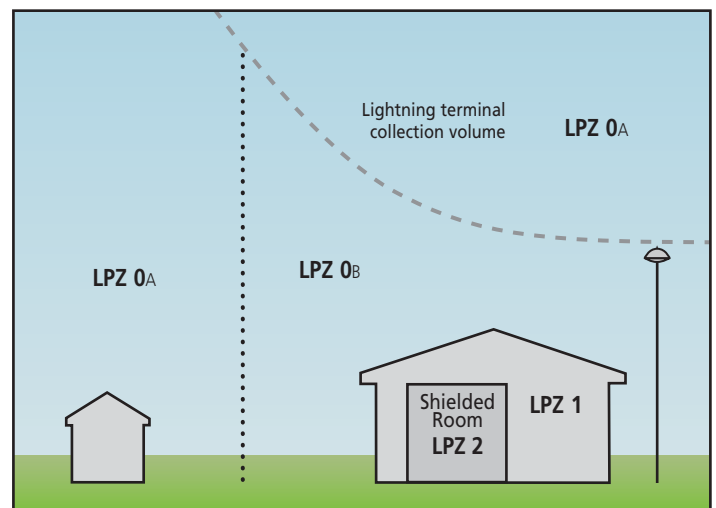

Protection zones defined by specific product application.

Advanced Technologies – The ERICO Advantage

Transient Discriminating Technology

To meet the fundamental requirements of performance, longer service life and greater safety under real world conditions, ERICO has developed Transient Discriminating (TD) Technology.

This quantum leap in technology adds a level of “intelligence” to the Surge Protection Device enabling it to discriminate between sustained abnormal over-voltage conditions and true transient or surge events. Not only does this help provide more reliable operation under practical application, but it also prolongs the life of the protector since permanent disconnects are not required as a means of achieving internal over-voltage protection.

Traditional Technologies

Conventional SPD technologies utilize metal oxide varistors and/or silicon avalanche diodes to clamp or limit transient events. However, these devices are susceptible to sustained 50/60Hz mains over-voltage conditions which often occur during faults to the utility system. Such occurrences present a significant safety hazard when the suppression device attempts to clamp the peak of each half cycle on the mains over-voltage. This condition can cause the device to rapidly accumulate heat and in turn fail with the possibility of inducing a fire hazard.

The Core of TD Technology

The secret to transient discriminating technology is its *active frequency discrimination* circuit. This patented device can

discriminate between a temporary over-voltage (TOV) condition and a very fast transient, which is associated with lightning or switching-induced surges. When the transient frequencies are detected, the patented Quick-Switch within TD activates to allow the robust protection to limit the incoming transient. The frequency discriminating circuit that controls the Quick-Switch helps ensure that the SPD device is immune to the effects of a sustained 50 or 60Hz TOV. This allows the device to keep operating, in order to help provide safe and reliable transient protection, even after an abnormal over-voltage condition has occurred.

Meeting & Exceeding UL® Standards

The range of surge protection devices from ERICO employing TD technology has been specifically designed to meet and exceed the new safety requirements of UL 1449 Edition 3. To meet the abnormal over-voltage testing of UL 1449 Edition 3, many manufacturers of SPD devices have incorporated fuse or thermal disconnect devices which permanently disconnect all protection from the circuit during an over-voltage event. Transient discriminating technology on the other hand will allow the SPD device to experience an abnormal over-voltage up to twice its nominal operating voltage and still remain operational even after this event! This allows the device to help provide reliable and continuous protection to your sensitive electronic equipment. TD technology is especially recommended for any site where sustained over-voltages are known to occur, and where failure of traditional SPD technologies cannot be tolerated.

The UL 1449 testing standard addresses the safety of an SPD device under temporary and abnormal overvoltage conditions, but does not specifically mandate a design that will give a reliable, long length of service in the real world. Specifically, UL 1449 tests that the SPD remains operational at 10% above nominal supply voltage, allowing SPD manufacturers to design products that permanently disconnect just above that. Most reputable manufacturer’s designs allow for up to a 25% overvoltage, while TD technology from ERICO gives even greater overhead.

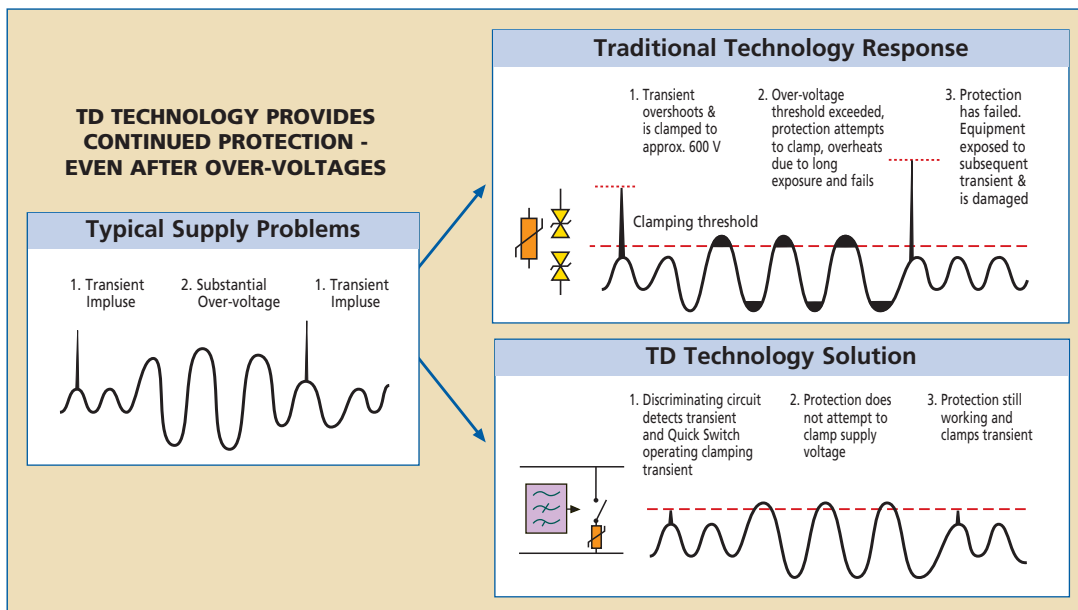
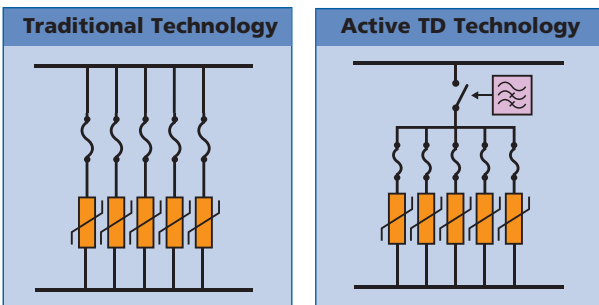

Glossary of Terminology

8/20 μ s Current Waveshape

A current impulse with a virtual front time of 8 μ s and a time to half-value of 20 μ s.

Aggregate Surge Rating

The sum of the surge ratings of individual voltage limiting components, connected in parallel, in the device.

Note: This figure does not indicate the maximum discharge current (I_{max}) of the device. It does however provide an indication of the expected SPD life. Users should be aware that certain manufacturers may incorrectly claim the aggregate surge rating of MOV material used in their device as its I_{max} . Non-perfect current sharing between parallel MOVs, and the inability of series over-current or thermal disconnects to carry the full surge current, generally means that the maximum discharge current which the SPD can withstand is less than its aggregate surge rating.

Attenuation

The ability of an SPD to reduce electrical noise interference, measured in decibels. Attenuation varies with frequency, so it is usual to specify the attenuation of the SPD at a particular frequency; commonly 100kHz.

Backup Overcurrent Protection

An external overcurrent protective device installed prior to the SPD. Such a device may be required if the overcurrent limiting device on the service is larger than that required by the SPD or connecting wiring.

Class I test

SPD tested with maximum impulse current (I_{imp}) and nominal discharge current (I_n).

Class II test

SPD tested with maximum discharge current (I_{max}) and nominal discharge current (I_n).

Class III test

SPD tested with combination wave.

Distribution System

Defines the electrical power distribution system. The distribution system is usually described by configuration of the phases, neutral and ground conductor configuration on the secondary side of the supply transformer. Refer to pages 10-12 for further information.

Follow Current (I_f)

The current supplied by the electrical power distribution system which flows through the SPD after a discharge current impulse. The follow current is significantly higher than the operating current, and is normally high for voltage switching type SPDs (e.g. spark gaps) since the arc voltage falls below the AC supply voltage after firing.

Impulse Current (I_{imp})

Peak impulse current withstand with a 10/350 μ s current waveshape. This is often used for the classification of SPDs tested to Test Class I, but is not the only acceptable waveshape.

Insertion Loss

The insertion loss of an SPD is usually only stated for two port devices for use on low voltage data systems. It is a measure of the ratio of voltage at the output to the input at the device under test. The insertion loss is usually stated for a given frequency and measured in decibels.

Leakage Current

The current flowing to the ground conductor when the SPD is connected to the nominal supply voltage U_n .

Let-through Voltage

Another term often used to describe the measured limiting voltage.

Note: This measurement may be carried out with, or without, the presence of the nominal AC power (U_n) being applied to the SPD. As such, the results may be different and the user should take cognizance of this in making any comparative assessments.

Location Categories

Various standards attempt to define the electrical environment at which an SPD may be installed, into location categories or zones.

Note: The user should be aware that international consensus has not been reached on these classifications, nor on the size of expected surge activity, which may occur. Further, the user should note that the demarcation of these zones do not form literal boundaries, but are rather a gradual transition.

Maximum Continuous Operating Voltage (U_c)

The maximum r.m.s. or d.c. voltage which may be continuously applied to the SPD's mode of protection without degradation or inhibiting its correct operation.

Note: Specifications given in the catalog generally are phase (L-N) voltages.

Maximum Discharge Current (I_{max})

The maximum single shot current, having an 8/20 μ s waveshape, which the SPD can safely divert.

Measured Limiting Voltage

The maximum voltage measured across the SPD's terminals during the application of an impulse of specified waveshape and amplitude.

Modes of Protection

SPDs may provide protection line-to-ground, line-to-neutral, neutral-to-ground or in combinations thereof. These paths are referred to as the modes of protection.

Note: The user is advised that not all modes require protection, and more is not necessarily better when selecting an SPD. As an example, the N-G mode is not required when the SPD is installed at the primary service entrance of a TN-C-S electrical distribution system, due to the Neutral-Ground bond at this point. The L-L mode is generally not provided for systems with neutral conductors since the L-N modes also protect the L-L modes. Similarly, the L-G mode can be protected via the L-N and N-G modes.

Nominal Discharge Current (I_n)

The peak value of the current flowing through the SPD during the application an 8/20 μ s waveshape.

Note: IEC 61643-1 requires SPDs tested to Test Class II, to withstand 15 impulses at I_n followed by 0.1, 0.25, 0.5, 0.75 and 1.0 times I_{max} .

Nominal (System) Voltage (U_n)

The L-N voltage by which an electrical power system is designated. Under normal system conditions, the voltage at the supply terminals may differ from the nominal voltage as determined by the tolerance of the supply system (normally +/- 10%).

One-port SPD

An SPD connected in shunt (parallel) with the circuit to be protected. A one port device may have separate input and output terminals, but without a specific series impedance between these terminals. This type of connection is also known as a Kelvin connection.

Glossary of Terminology

Operating Current

The current drawn (per phase) by the SPD when energized at the nominal operating voltage U_n .

Note: For SPDs with integral series filtering, the total current drawn may be greater than the real rms current consumption (i.e. VA may be greater than Watts). This is due to the presence of the internal filtering capacitance.

Over-current Protection

An over-current device, such as a fuse or circuit-breaker, which could be part of the electrical distribution system located externally and up-stream of the SPD. May provide protection to the SPD, the connecting wiring and provide a means of externally isolating the SPD.

Protective Earth (PE)

The IEC® 60364 series characterizes low-voltage distribution systems by their grounding methods and the configuration of the neutral and protective conductors. The Protective Earth is commonly referred to as "ground", or "earth", in many regions.

Rated Load Current (I_L)

Maximum continuous rated current that can be supplied to a load connected to the protected output of an SPD. Normally only stated for two port, series connected, SPDs.

Residual Voltage

In IEC terminology this refers to the peak value of the voltage that appears between the terminals of an SPD due to the passage of discharge current I_n . NZS/AS 1768 refers to this as the let-through voltage, a measurement obtained when the stated test impulse is superimposed on top of the nominal system voltage U_n .

Secondary Surge Arrester

A loosely used term given to SPDs intended for operation on medium voltage systems (>1kV). Within the USA, a secondary surge arrester defines an SPD Listed by Underwriters Laboratories Inc. for use on LV and MV systems at locations prior to the main overcurrent disconnect to the facility.

Note: Secondary Surge Arrester Listing is generally considered to have less demanding safety requirements than those for UL® 1449 Transient Voltage Surge Arrester Listing.

Short Circuit Current Rating (SCCR)

The short-circuit current rating of the SPD. Required by USA National Electric Code (NEC®) for TVSS devices.

SPD Disconnect

An IEC term used to describe a device (internal and/or external) for disconnecting an SPD from the electrical power system.

Note: This disconnecting device is not required to have isolating capability. It is to prevent a persistent fault on the system and is used to give an indication of the SPD failure. There may be more than one disconnecter function, for example an over-current protection function and a thermal protection function. These functions may be integrated into one unit or performed in separate units.

Spark-over Voltage

The voltage at which a switching type SPD (generally of the spark gap type) will initiate conduction. This value is normally specified for a voltage increasing at 1kV/s.

Stand-off Voltage

The maximum voltage, which can be applied to an SPD, without triggering it into a fully conductive state.

Note: This voltage is normally higher than the maximum continuous operating voltage (MCOV or U_c) of the SPD. It is not intended that the SPD be operated at this voltage.

Status Indicator

A device(s) that indicates the operational status of the SPD, or of a particular mode of its protection.

Note: Such indicators may be local with visual and/or audible alarms and/or may have remote signaling and/or output contact capability.

Suppressed Voltage Rating (SVR)

A special case of the measured limiting voltage specific to the UL 1449 Listing of an SPD.

Note: This test is performed using a small 500A 8/20 μ s current limited impulse, and the clamping voltage recorded at the ends of 6" connecting leads. The result obtained is rounded up to the nearest value given in a table.

Surge Protection Device (SPD)

An IEC term used to describe a device intended to limit transient over-voltages and divert surge currents. It contains at least one non-linear component.

Surge (Reduction) Filter

A two-port series filtering type of SPD specifically designed to reduce the rate-of-rise of voltage (dv/dt) of the pre-clamped waveform. Such a device normally contains a filter with low-pass performance.

Transient Voltage Surge Suppressor (TVSS)

An SPD tested to meet the safety requirements of UL 1449 - Standard for Transient Voltage Surge Suppressors. UL 1449 defines the basic safety requirements for TVSS devices installed on electrical circuits up to 600V. The United States National Electric Code (NEC) only permits TVSS devices to be installed after (downstream of) the main over-current disconnect to a facility.

Two-port SPD

An SPD with two sets of terminals, input and output (line and equipment), and with a specific impedance inserted between these terminals. These are often referred to as series (in-line) connected SPDs and generally contain wave-shaping filters in addition to simple shunt-only protection.

Voltage Protection Level (U_p)

Similar to the measured limiting voltage, the voltage protection level characterizes the performance of an SPD in limiting the voltage across its terminals.

Note: The voltage protection level is the measured limiting voltage recorded under a specified current magnitude and waveshape, and rounded up to the next highest voltage selected from a list of preferred values found in IEC 61643-1 Standard for surge protective devices connected to low-voltage power distribution systems. For SPDs tested to Test Class I, U_p is generally stated using a 10/350 I_{imp} and for SPDs tested to Test Class II, using an 8/20 μ s I_{max} .

Voltage Protection Rating (VPR)

A rating selected from a list of preferred values as given in Table 63.1 of ANSI®/UL 1449 and assigned to each mode of protection. The value of the VPR is determined as the nearest highest value taken from Table 63.1 to the measured limiting voltage determined during the transient-voltage surge suppression test using the combination wave generator at a setting of 6 kV, 3 kA.



Service Entrance Suppression



Features

- Compact NEMA®-4X enclosure design can be flush mounted or installed in a small space
- LED status indication flag for status monitoring
- 40 kA 8/20 μ s maximum surge rating provides protection suitable for service entrance and distribution panels
- CE, UL® 1449 Edition 3 Listed
- Optional bracket for mounting within panel backplane

The SES40 Series of Surge Protection Devices provide economical protection against damaging transients and surge events. These products are UL and cUL® listed to 1449 Edition 3 as Type 1 devices. This allows them to be installed on the line or load side of the service panel in accordance with the NEC® 2011 without the requirement for additional circuit breakers or fuses. The DC models have an additional listing under UL 1449 for use on photovoltaic systems.

Primary applications are service entrance, branch and OEM panels, solar cominer boxes, UL 96A lightning protection installations and light pole applications. The housing is constructed of UV-stabilized thermo-plastic and designed to meet the UL 50 Type 4 rating, making it ideal for both indoor and outdoor NEMA 4X applications. Most models have a 20kA nominal discharge current rating, the highest level recognized under UL 1449 Edition 3 standard. Listed as a Type 1 SPD to UL 1449 3rd Edition, the SES40 Series can be installed in a Type 1 or 2 location in accordance with the NEC 2011.

Model	SES40120/240SP	SES401201P	SES402083P	SES402401P	SES404803P	SES404801P	SES40300DC	SES40600DC
Nominal System Voltage, U_n	120/240 V	120 V	120/208 V	240 V	277/480 V	480 V	300 Vdc	600 Vdc
Distribution System	1Ph 2W+G	1Ph 2W+G	3Ph 4W+G 3Ph Δ 3W+G	1Ph 2W+G	3Ph 4W+G 3Ph Δ 3W+G	1Ph 2W+G	DC 2W G	DC 2W+G
Max Cont. Operating Voltage, U_c	150/300 VAC	150 VAC	150/300 VAC	300 VAC	340/590 VAC	580 VAC	360 VDC	600 VDC
Frequency	0-60 Hz							
Max Discharge Current, I_{max}	40 kA 8/20 μ s per mode							
Nominal Discharge Current, I_n	20kA 8/20 μ s per mode							10 kA 8/20 μ s per mode
Protection Modes	L-N, L-L	L-G, N-G	L-N, L-G, N-G, L-L	L-G, N-G	L-N, L-G, N-G, L-L	L-G, N-G	+ve to G, -ve to G	+ve to G, -ve to G
Technology	MOV with thermal disconnect							
Short Circuit Current Rating, I_{sc}	200 kAIC						100 kAIC	
Voltage Protection Rating (VPR)	800 V @ 3kA	800 V @ 3kA	800 V @ 3kA	1200 V @ 3kA	1200 V @ 3kA	1200 V @ 3kA	1,500V @ 3 kA	2,500V @ 3 kA
Status	LED indicator							
Dimensions H x D x W: mm (in)	62 x 87 x 99 (2.44 x 3.43 x 3.90)							
Weight: kg (lbs)	0.18 (0.40)		0.32 (0.70)	0.18 (0.40)	0.32 (0.70)	0.18 (0.40)		
Enclosure	NEMA 4X, UV stabilized thermoplastic							
Connection	#12 AWG Wiring Leads							
Mounting	3/4" straight nipple with conduit nut for mounting through standard 1.14" diameter knockout							
Temperature	-40°C to 80°C (-40°F to 176°F)							
Approvals	CE, UL 1449 Edition 3 Listed Type 1/2					CE	CE, UL 1449 Ed. 3 for DC general use	CE, UL 1449 Ed. 3 for DC PV use
Surge Rated to Meet	UL 1449 Edition 3 In 20 kA mode							UL 1449 Ed. 3 in 10 kA mode
Available Options	Mounting bracket (SES40BRK)							

Service Entrance Suppression



Features

- Compact NEMA®-4 enclosure design can be flush mounted or installed in a small space
- LED status indication flag for status monitoring
- 120/240 VAC operating voltage suits the most common power distribution system for residential or small commercial buildings
- 40 kA 8/20 μ s maximum surge rating provides protection suitable for service entrance and distribution panels
- CE, UL® 1449 Edition 3 Listed



Lightning transients and surges are a major cause of expensive electronic equipment failure and business disruption. Damage to computers, data and communications may occur, as well as a loss of revenue and profits. The SES40 Service Entrance Suppression, part of the ERITECH® line of facility electrical protection products from ERICO, is designed to protect sensitive electronics at the service entrance for residential or light commercial service panels.

This economical unit is designed for 120/240 VAC power systems and provides surge protection totaling 80 kA 8/20 μ s total, or 40 kA per phase. The SES40 is UL Listed as a Type 1 device. It offers a simple and hassle-free installation for protection on the line side or load side of the service panel, without additional external protection being required by circuit breakers or fuses.

Model	SES40120/240
Nominal System Voltage, U_n	120/240 V
Distribution System	1Ph 3W+G
Max Cont. Operating Voltage, U_c	170/340 VAC
Frequency	50/60 Hz
Max Discharge Current, I_{max}	40 kA 8/20 μ s
Nominal Discharge Current, I_n	20kA 8/20 μ s
Protection Modes	L-G
Technology	MOV with thermal disconnect
Short Circuit Current Rating, I_{sc}	200 kAIC (I_{sc})
Voltage Protection Rating (VPR) (8/20μs)	L-N 800 V @ 3 kA 1.2 kV @ 20 kA
Status	LED indicator
Dimensions H x D x W: mm (in)	83 x 73 x 83 (3.27 x 2.87 x 3.27)
Weight: kg (lbs)	0.7 (1.54)
Enclosure	Aluminum, IP 65 (NEMA-4)
Connection	Line: 762 mm of 5.26 mm ² (30" of # 10 AWG) flying leads Neutral/Ground: 900 mm of 5.26 mm ² (36" of # 10 AWG) flying leads
Mounting	3/4" straight nipple
Temperature	-40°C to 80°C (-40°F to 176°F)
Approvals	CE, UL 1449 Edition 3 Listed Type 1/2
Surge Rated to Meet	ANSI/IEEE® C62.41.2-2002 Cat A, Cat B, Cat C ANSI/IEEE® C62.41.2-2002 Scenario II, Exposure 1, 20 kA 8/20 μ s, 2 kA 10/350 μ s EC 61643-1 Class II UL 1449 Edition 3 In 20 kA mode
Available Options	Flush Mount Kit (Order SES40FP) Side Mount Kit (Order TDXSM)



NEMA is a registered trademark of the National Electrical Manufacturers Association. ANSI is a registered trademark of the American National Standards Institute. IEEE is a registered trademark of the Institute of Electrical and Electronics Engineers, Incorporated. UL is a registered certification mark of UL LLC.

Transient Discriminating Service Entrance Suppressor



Features

- 200kA 8/20 μ s primary protection – rated for service entrance applications
- NEMA[®]-4X enclosure – for harsh environments
- Internal high interrupt capacity fusing – for added safety
- Modular design – allows easy replacement of surge modules
- Built in disconnect and fusing eliminates need for external fusing
- Transient Discriminating (TD) Technology – provides increased service life
- Optional Filter and Surge Counter – for enhanced protection
- UL[®] 1449 Edition 3 Listed

The SES200 series of Transient Voltage Surge Suppressors deliver specification grade performance and features at an affordable price. The versatile and compact design provides high quality protection for a wide variety of commercial and industrial applications where sensitive electronic equipment is to be protected.

Internal electronics continuously monitor SPD protection, and the status is displayed on 5 segment LED bar graphs. Alarm contacts for remote monitoring are a standard feature.

The SES200 provides up to 200kA 8/20 μ s per mode of surge material, making it ideal for the protection of service entrance panels and helping to ensure a long operational life under severe lightning conditions.

The replaceable surge modules provide protection to L-N and N-G modes, delivering effective protection from both common mode and differential transients in single phase and three phase WYE systems. Models for grounded delta power systems provide L-L protection.

Transient Discriminating (TD) Technology, which meets the safety standards of UL 1449 Edition 3, provides a superior life by eliminating the common temporary over-voltage failure mode of most SPDs.

The SES is designed to mount adjacent to the service entrance panel with the connection being made via a small length of conduit.



SES200 metal enclosure option



SES200 without filter or surge counter options

Note: Ensure that installation of this model of the SES200 is not exposed to direct sunlight as solar radiation may cause internal temperatures to exceed the maximum specified and damage will result to the surge protective modules. A sun shield should be fitted if this unit is to be installed outdoors and exposed to sunlight.

Model	SES200 120/208	SES200 120/240	SES200 240D	SES200 277/480	SES200 120/208CM	SES200 120/240CM	SES200 240DCM	SES200 277/480CM
Nominal Voltage, U_n	120/208 V	120/240 V	220/240 V	277/480 V	120/208 V	120/240 V	220/240 V	277/480 V
Distribution System	3Ph Y 4W+G	1Ph 3W+G	3Ph Δ 3W+G	3Ph Y 4W+G		1Ph 3W+G	3Ph Δ 3W+G	3Ph Y 4W+G
System Compatibility⁽¹⁾	TN-C, TN-S, TN-C-S							
Max Cont. Operating Voltage, U_c	170/295 VAC	170/340 VAC	400 VAC	400/692 VAC	170/295 VAC	170/340 VAC	400 VAC	400/692 VAC
Stand-off Voltage	240/415 V	240/480 V	275 V	480/831 V	240/415 V	240/480 V	275 V	480/831 V
Frequency	50/60 Hz							
Operating Current @ U_n	25 mA							
Aggregate Surge Rating	200kA (8/20μs per line)							
Impulse Current, I_{imp}	20 kA 10/350 μs							
Max Discharge Current, I_{max}	100 kA 8/20 μs							
Nominal Discharge Current, I_n	80 kA 8/20 μs							
Protection Modes	All modes protected		L-L	All modes protected			L-L	All modes protected
Technology	MOV/Silicon with over-current fusing TD Technology							
Short Circuit Current Rating	200 kAIC							
Voltage Protection Rating (VPR)	L-N 600 V @ 3 kA 800 V @ 20 kA	L-L 900 V @ 3 kA 1.0 kV @ 20 kA	L-N 900 V @ 3 kA 1.0 kV @ 20 kA	L-N 900 V @ 3 kA 1.0 kV @ 20 kA	L-N 600 V @ 3 kA 800 V @ 20 kA	L-L 900 V @ 3 kA 1.0 kV @ 20 kA	L-N 900 V @ 3 kA 1.0 kV @ 20 kA	L-N 900 V @ 3 kA 1.0 kV @ 20 kA
Filtering					-40 dB @ 100 kHz			
Status⁽²⁾	5 segment LED bar graph per phase				5 segment LED bar graph per phase, surge counter			
Dimensions H x D x W: mm (in)	406 x 190 x 305 (16 x 7.5 x 12)				406 x 190 x 355 (16 x 7.5 x 14)			
Weight: kg (lbs)	8 (17.64)				13 (28.66)			
Enclosure	IP66 (NEMA®-4X), Polycarbonate				IP66 (NEMA-4), Metal (Steel)			
Connection	3mm ² to 35mm ² (#12AWG to #2AWG)							
Mounting	Wall mount							
Back-up Overcurrent Protection	Fused disconnect included in enclosure							
Temperature	-10°C to 60°C (14°F to 140°F)							
Approvals	NOM, UL® 1449 Edition 3 Listed Type 1/2							
Surge Rated to Meet	ANSI®/IEEE® C62.41.2-2002 Cat A, Cat B, Cat C ANSI®/IEEE® C62.41.2-2002 Scenario II, Exposure 3, 100 kA 8/20 μs, 10 kA 10/350 μs UL 1449 Edition 3 In 20 kA mode							

(1) Grounded systems only. SES200 240D should not be used on high leg or underground systems.

(2) Normally open contact, 250V~10A, ≤1.5 mm² (#16AWG) connecting wire.

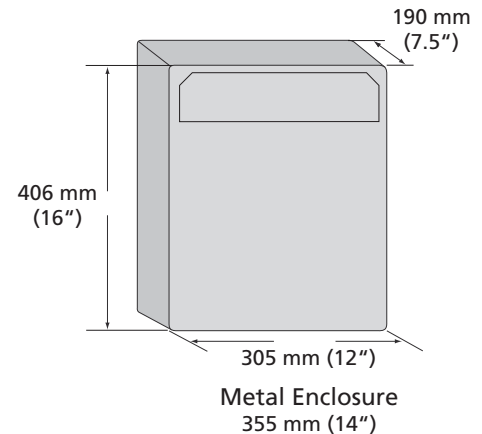
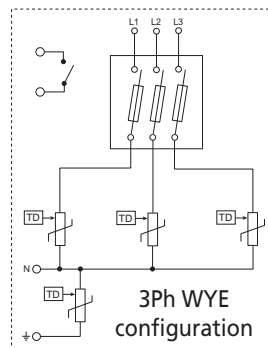
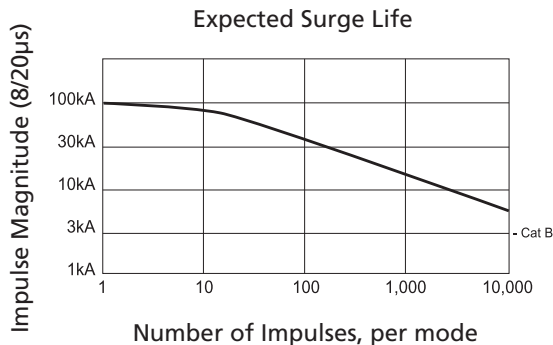

ANSI is a registered trademark of the American National Standards Institute. IEEE is a registered trademark of the Institute of Electrical and Electronics Engineers, Incorporated. NEMA is a registered trademark of the National Electrical Manufacturers Association. UL is a registered certification mark of UL LLC.

TDX400S Transient Discriminating Panel Protection



Features

- Transient Discriminating (TD) Technology provides increased service life
- Modular design allows individual modes to be field replaceable, built-in disconnect and fusing eliminates need for external fusing
- Built-in features include TD Technology, thermal protection, short circuit current cartridge fusing and a surge counter
- Status indication flag per mode, voltage presence LED's, audible alarm and voltage-free contacts providing remote status monitoring
- Available in various operating voltages to suit most common power distribution systems
- 400kA 8/20 μ s maximum surge rating provides protection suitable for service entrance, main-distribution panels and highly exposed applications
- CE, UL[®] 1449 Edition 3 Listed

The TDX400 Series of Transient Voltage Surge Suppressors is designed for critical protection applications. The 400kA 8/20 μ s of surge protection exceeds the IEEE[®] C62.41.2 Scenario II single shot surge rating requirements for exposed service entrance locations – Exposure 3.

The NEMA[®]-1 weather-tight housing allows the TDX to be installed on indoor panels.

The preconfigured connecting leads simplify installation. The unique narrow construction allows the SPD to fit between adjacent panel boards and connect via a 90-degree elbow.

Listed as a Type 1 SPD to UL 1449 Edition 3, the TDX400 Series can be installed within a Type 1 or 2 location in accordance with the NEC[®] 2008.

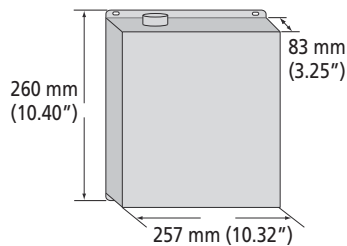

Model	TDX400S120/208	TDX400S120/240	TDX400S277/480	TDX400S277/480T
Nominal Voltage, U _n	120/208 V	120/240 V	277/480 V	
Distribution System	3Ph 4W+G	1Ph 3W+G	3Ph 4W+G	
Max Cont. Operating Voltage, U _c	170/295 VAC	170/340 VAC	320/536 VAC	
Stand-off Voltage	240/415 VAC	240/480 VAC	480/831 VAC	
Frequency	50/60 Hz			
Short Circuit Current Rating, I _{sc}	200 kAIC			
Technology	Over-current Replaceable Cartridge Fusing TD Technology with thermal disconnect			
Max Discharge Current I _{max}	400 kA 8/20 μ s per phase			
Impulse Current, I _{imp}	25 kA 10/350 μ s per mode			
Nominal Discharge Current	160 kA 8/20 μ s			
Protection Modes	All modes protected via L-G, L-N, N-G			L-N, N-G
Voltage Protection Rating (VPR) (8/20 μ s)	L-N 800 V @ 3 kA		L-N 1.2 kV @ 3 kA	
Status	Audible Alarm LED status indication per phase, mechanical flag per mode, all modes monitored Form A remote contacts, max 1.5 mm ² (#14 AWG) terminals			
Dimensions H x D x W: mm (in)	260 x 83 x 257 (10.40 x 3.25 x 10.32)			
Weight: kg (lbs)	6.35 (14.00)			
Enclosure	Aluminum, IP 65 (NEMA [®] -1)			
Connection	Line: 762 mm of 5.26 mm ² (30" of # 10 AWG) flying leads Neutral/Ground: 900 mm of 5.26 mm ² (36" of # 10 AWG) flying leads			
Mounting	3/4" straight nipple			
Temperature	-40°C to 80°C (-40°F to 176°F)			
Approvals	C-Tick, CE, IEC [®] 61643-1, UL 1449 Edition 3 Listed Type 1/2			
Surge Rated to Meet	ANSI/IEEE [®] C62.41.2-2002 Cat A, Cat B, Cat C ANSI/IEEE [®] C62.41.2-2002 Scenario II, Exposure 3, 100 kA 8/20 μ s, 10 kA 10/350 μ s IEC 61643-1 Class I, Class II UL 1449 Edition 3 In 20 kA mode			
Available Options	Replacement Fuse Cartridge (Order TDXFUSE) Replacement Surge Module (Order TDS150M150 or TDS150M277), please refer to installation instructions			
Replacement Modules	TDS150M150	TDS150M150	TDS150M277	SGD125M (N-G), TDS150M277

ANSI is a registered trademark of the American National Standards Institute. IEC is a registered trademark of the International Electrotechnical Commission. IEEE is a registered trademark of the Institute of Electrical and Electronics Engineers, Incorporated. NEMA is a registered trademark of the National Electrical Manufacturers Association. UL is a registered certification mark of UL LLC.

TDX300S Transient Discriminating Panel Protection



Features

- Transient Discriminating (TD) Technology provides increased service life
- Modular design allows individual modes to be field replaceable, built-in disconnect and fusing eliminates need for external fusing
- Built-in features include TD Technology, thermal protection, short circuit current cartridge fusing and surge counter
- Status indication flag per mode, voltage presence LED's, audible alarm and voltage-free contacts providing remote status monitoring
- Available in various operating voltages to suit most common power distribution systems
- 300kA 8/20 μ s maximum surge rating provides protection suitable for service entrance, main-distribution panels and highly exposed applications
- CE, UL® 1449 Edition 3 Listed

The TDX300 Series of Transient Voltage Surge Suppressors is designed for critical protection applications. The 300kA 8/20 μ s of surge protection exceeds the IEEE® C62.41.2 Scenario II single shot surge rating requirements for exposed service entrance locations – Exposure 3.

The NEMA®-1 weather-tight housing allows the TDX to be installed on indoor panels.

The preconfigured connecting leads simplify installation. The unique narrow construction allows the SPD to fit between adjacent panel boards and connect via a 90-degree elbow.

Listed as a Type 1 SPD to UL 1449 Edition 3, the TDX300 Series can be installed within a Type 1 or 2 location in accordance with the NEC® 2008.

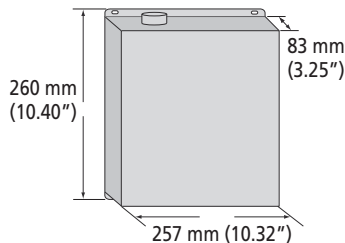

Model	TDX300S120/208	TDX300S120/240	TDX300S277/480
Nominal Voltage, U _n	120/208 V	120/240 V	277/480 V
Distribution System	3Ph 4W+G	1Ph 3W+G	3Ph 4W+G
Max Cont. Operating Voltage, U _c	170/295 V AC	170/340 V AC	320/536 V AC
Stand-off Voltage	240/415 V	240/480 V	480/831 V
Frequency	50/60 Hz		
Short Circuit Current Rating, I _{sc}	200 kAIC		
Technology	Over-current Replaceable Cartridge Fusing TD Technology with thermal disconnect		
Max Discharge Current I _{max}	300 kA 8/20 μ s per phase		
Impulse Current, I _{imp}	22.5 kA 10/350 μ s per mode		
Nominal Discharge Current	120 kA 8/20 μ s		
Protection Modes	All modes protected via L-G, L-N, N-G		
Voltage Protection Rating (VPR) (8/20 μ s)	L-N 800 V @ 3 kA		L-N 1.2 kV @ 3 kA
Status	Audible Alarm LED status indication per phase, mechanical flag per mode, all modes monitored Form A remote contacts, max 1.5 mm ² (#14 AWG) terminals		
Dimensions H x D x W: mm (in)	260 x 83 x 257 (10.40 x 3.25 x 10.32)		
Weight: kg (lbs)	5.9 (13.00)		
Enclosure	Aluminum, IP 65 (NEMA®-1)		
Connection	Line: 762 mm of 5.26 mm ² (30" of # 10 AWG) flying leads Neutral/Ground: 900 mm of 5.26 mm ² (36" of # 10 AWG) flying leads		
Mounting	3/4" straight nipple		
Temperature	-40°C to 80°C (-40°F to 176°F)		
Approvals	C-Tick, CE, IEC® 61643-1, UL 1449 Edition 3 Listed Type 1/2		
Surge Rated to Meet	ANSI®/IEEE® C62.41.2-2002 Cat A, Cat B, Cat C ANSI®/IEEE® C62.41.2-2002 Scenario II, Exposure 3, 100 kA 8/20 μ s, 10 kA 10/350 μ s IEC 61643-1 Class I, Class II UL 1449 Edition 3 In 20 kA mode		
Available Options	Replacement Fuse Cartridge (Order TDXFUSE) Replacement Surge Module (Order TDS150M150 or TDS150M277), please refer to installation instructions		
Replacement Module	TDS150M150		TDS150M277



ANSI is a registered trademark of the American National Standards Institute. IEC is a registered trademark of the International Electrotechnical Commission. IEEE is a registered trademark of the Institute of Electrical and Electronics Engineers, Incorporated. NEMA is a registered trademark of the National Electrical Manufacturers Association. UL is a registered certification mark of UL LLC.

TDX200 Transient Discriminating Panel Protection



Features

- Transient Discriminating (TD) Technology provides increased service life
- Modular design allows individual modes to be field replaceable, built-in disconnect and fusing eliminates need for external fusing
- Built-in features include TD Technology, thermal protection and short circuit current cartridge fusing
- Compact NEMA®-4 enclosure design can be flush mounted or installed in a small space
- Status indication flag per mode, voltage presence LED's, audible alarm and voltage-free contacts providing remote status monitoring
- 200kA 8/20µs maximum surge rating provides protection suitable for service entrance, main-distribution panels and highly exposed applications
- Available in various operating voltages to suit most common power distribution systems
- CE, UL® 1449 Edition 3 Listed

The TDX200 Series of Transient Voltage Surge Suppressors is designed for critical protection applications. The 200kA 8/20µs of surge protection exceeds the IEEE® C62.41.2 Scenario II single shot surge rating requirements for exposed service entrance locations – Exposure 3.

The NEMA-4 weather-tight housing allows the TDX to be installed on indoor or outdoor service panels. The

preconfigured connecting leads simplify installation. The unique narrow construction allows the SPD to fit between adjacent panel boards and connect via a 90-degree elbow. A flush mounting kit is also available for installing the SPD in drywall applications.

Listed as a Type 1 SPD to UL 1449 Edition 3, the TDX200 Series can be installed within a Type 1 or 2 location in accordance with the NEC® 2008



Typical installation



TDX200M Enclosure



TDX Replaceable Modules



TDX Replaceable Module backplane fully removed

Model	TDX200M 120/208	TDX200M 120/240	TDX200M 120/240D	TDX200M 240D	TDX200M 277/480	TDX200M 277/480TT*	TDX200M 347/600	TDX200M 480D	
Nominal Voltage, U _n	120/208 V		240 V		277/480 V		347/600 V	480 V	
Distribution System	3Ph 4W+G	1Ph 3W+G	3Ph Δ 4W+G	3Ph Δ 3W+G	3Ph 4W+G		3Ph Δ 3W+G		
Max Cont. Operating Voltage, U _c	170/295 VAC	170/340 VAC		275 VAC	320/536 VAC		610/970 VAC	610 VAC	
Stand-off Voltage	240/415 VAC	240/480 VAC	240/415 VAC	415 VAC	480/831 VAC		790/1370 VAC	790 VAC	
Frequency	50/60 Hz								
Short Circuit Current Rating, I _{sc}	200 kAIC								
Technology	Over-current Replaceable Cartridge Fusing TD Technology with thermal disconnect								
Max Discharge Current, I _{max}	200 kA 8/20 μs per phase								
Impulse Current, I _{imp}	20 kA 10/350 μs per mode					20 kA 10/350 μs per mode	20 kA 10/350 μs per mode		
Nominal Discharge Current, I _n	100 kA 8/20 μs			80 kA 8/20 μs					
Protection Modes	All modes protected via L-N, L-G & N-G								
Voltage Protection Rating (VPR)	L-N 600 V @ 3 kA 1.2 kV @ 20 kA			L-L 1.0 kV @ 3 kA 1.8 kV @ 20 kA	L-N 1.0 kV @ 3 kA 1.8 kV @ 20 kA		L-N 1.8 kV @ 3 kA 2.6 kV @ 20 kA	L-L 1.8 kV @ 3 kA 2.6 kV @ 20 kA	
Status	Audible Alarm LED status indication per phase, mechanical flag per mode, all modes monitored Form A remote contacts, max 1.5 mm ² (#14 AWG) terminals								
Dimensions H x D x W: mm (in)	240 x 78 x 130 (9.45 x 3.07 x 5.12)								
Weight: kg (lbs)	2.0 (4.4)								
Enclosure	Aluminum, IP 65 (NEMA®-4)								
Connection	Line: 762 mm of 5.26 mm ² (30" of # 10 AWG) flying leads Neutral/Ground: 900 mm of 5.26 mm ² (36" of # 10 AWG) flying leads								
Mounting	3/4" straight nipple; Optional flush mounting plate for drywall								
Temperature	-40°C to 80°C (-40°F to 176°F)								
Approvals	C-Tick, CE, IEC® 61643-1, UL 1449 Edition 3 Listed Type 1/2								
Surge Rated to Meet	ANSI®/IEEE® C62.41.2-2002 Cat A, Cat B, Cat C ANSI®/IEEE® C62.41.2-2002 Scenario II, Exposure 3, 100 kA 8/20 μs, 10 kA 10/350 μs IEC 61643-1 Class I, Class II UL® 1449 Edition 3 In 20 kA mode								
Available Options	Flush Mount Kit (Order TDXM200FP) Replacement Fuse Cartridge (Order TDXFUSE) Side Mount Kit (Order TDXSM) Surge Counter and Filtering insert "S" in Order Code, example TDX100S277/480								
Replacement Module	TDS150M150		TDS150M150 TDS150M240	TDS150M240	TDS150M277	TDS150M277 (L-N) SGD125M (N-G)	TDS150M560		

Delta and "S" models are Type 2 devices.

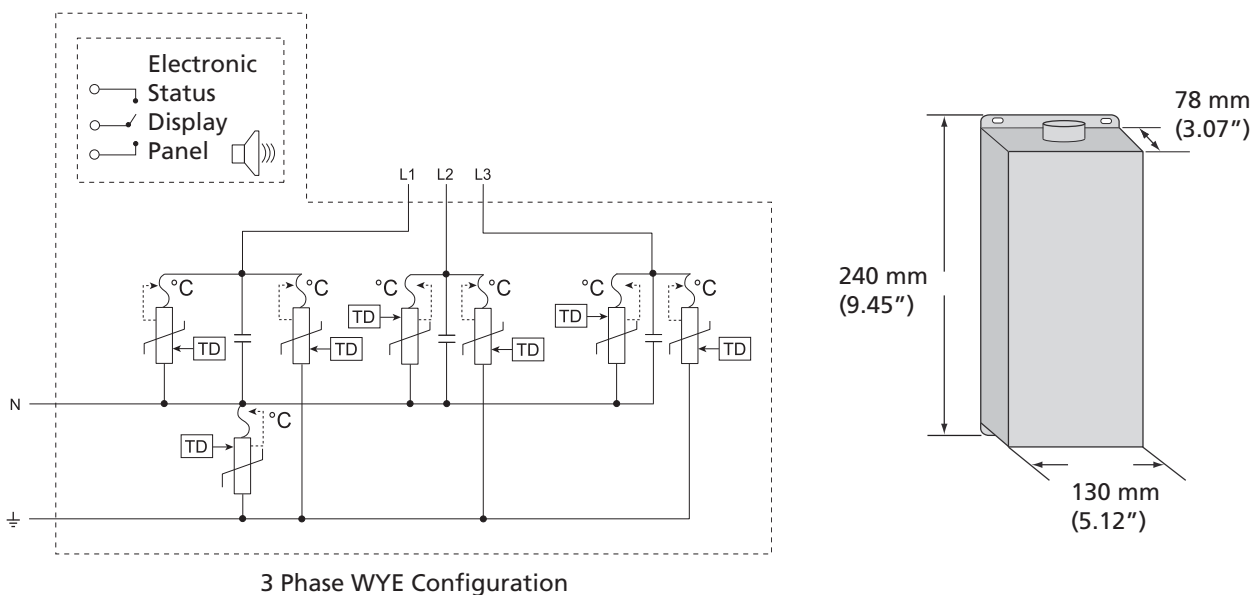

ANSI is a registered trademark of the American National Standards Institute. IEC is a registered trademark of the International Electrotechnical Commission. IEEE is a registered trademark of the Institute of Electrical and Electronics Engineers, Incorporated. NEMA is a registered trademark of the National Electrical Manufacturers Association. UL is a registered certification mark of UL LLC.

TDX100 Transient Discriminating Panel Protection



Features

- Transient Discriminating (TD) Technology provides increased service life
- Modular design allows individual modes to be field replaceable, built-in disconnect and fusing eliminates need for external fusing
- Built-in features include TD Technology, thermal protection and short circuit current cartridge fusing
- Compact NEMA®-4 enclosure design can be flush mounted or installed in a small space
- Status indication flag per mode, voltage presence LEDs, audible alarm and voltage-free contacts providing remote status monitoring
- 100kA 8/20µs maximum surge rating provides protection suitable for smaller main-distribution panels and an extended operational life
- Available in various operating voltages to suit most common power distribution systems
- CE, UL® 1449 Edition 3 Listed

The TDX100 Series of Transient Voltage Surge Suppressors is designed for critical protection applications. The 100kA 8/20µs of surge protection meets the IEEE® C62.41.2 Scenario II single shot surge rating requirements for exposed service entrance locations – Exposure 3.

The NEMA-4 weather tight housing allows the TDX to be installed on indoor or outdoor service panels. The

preconfigured connecting leads simplify installation. The unique narrow construction allows the SPD to fit between adjacent panel boards and connect via a 90-degree elbow. A flush mounting kit is also available for installing the SPD in drywall applications.

Listed as a Type 1 SPD to UL 1449 Edition 3, the TDX100 Series can be installed within a Type 1 or 2 location in accordance with the NEC® 2008



Typical Installation



Output contacts



TDX Replaceable Cartridge
overcurrent fuse protection



TDX Replaceable Modules

Model	TDX100M 120/208	TDX100M 120/240	TDX100M 120/240D	TDX100M 240D	TDX100M 277/480	TDX100M 277/480TT*	TDX100M 347/600	TDX100M 480D
Nominal Voltage, U _n	120/208 V		240 V		277/480 V		347/600 V	
Distribution System	3Ph 4W+G	1Ph 3W+G	3Ph Δ 4W+G	3Ph Δ 3W+G	3Ph 4W+G		3Ph Δ 3W+G	
Max Cont. Operating Voltage, U _c	170/295 VAC	170/340 VAC	275 VAC		320/536 VAC		610/970 VAC	610 VAC
Stand-off Voltage	240/415 VAC	240/480 VAC	240/415 VAC	415 VAC	480/831 VAC		790/1370 VAC	790 VAC
Frequency	50/60 Hz							
Short Circuit Current Rating, I _{sc}	200 kAIC							
Technology	Over-current Replaceable Cartridge Fusing TD Technology with thermal disconnect							
Max Discharge Current, I _{max}	100 kA 8/20 μs per phase							
Impulse Current, I _{imp}	12 kA 10/350 μs per mode					12 kA 10/350 μs per mode	12 kA 10/350 μs per mode	
Nominal Discharge Current, I _n	50 kA 8/20 μs			40 kA 8/20 μs				
Protection Modes	All modes protected via L-N, L-G & N-G							
Voltage Protection Rating (VPR)	L-N 600 V @ 3 kA 1.2 kV @ 20 kA			L-L 1.0 kV @ 3 kA 1.8 kV @ 20 kA	L-N 1.2 kV @ 3 kA 1.8 kV @ 20 kA	L-N 1.8 kV @ 3 kA 2.6 kV @ 20 kA		L-L 1.8 kV @ 3 kA 2.6 kV @ 20 kA
Status	Audible Alarm LED status indication per phase, mechanical flag per mode, all modes monitored Form A remote contacts, max 1.5 mm ² (#14 AWG) terminals							
Dimensions H x D x W: mm (in)	240 x 78 x 84 (9.45 x 3.07 x 3.31)							
Weight: kg (lbs)	1.41 (3.1)							
Enclosure	Aluminum, IP 65 (NEMA®-4)							
Connection	Line: 762 mm of 5.26 mm ² (30" of # 10 AWG) flying leads Neutral/Ground: 900 mm of 5.26 mm ² (36" of # 10 AWG) flying leads							
Mounting	3/4" straight nipple; Optional flush mounting plate for drywall							
Temperature	-40°C to 80°C (-40°F to 176°F)							
Approvals	C-Tick, CE, IEC® 61643-1, UL 1449 Edition 3 Listed Type 1/2							
Surge Rated to Meet	ANSI/IEEE® C62.41.2-2002 Cat A, Cat B, Cat C ANSI/IEEE® C62.41.2-2002 Scenario II, Exposure 3, 100 kA 8/20 μs, 10 kA 10/350 μs IEC 61643-1 Class I, Class II UL® 1449 Edition 3 In 20 kA mode							
Available Options	Flush Mount Kit (Order TDXM100FP) Replacement Fuse Cartridge (Order TDXFUSE) Side Mount Kit (Order TDXSM) Surge Counter and Filtering insert "S" in Order Code, example TDX100S277/480							
Replacement Module	TDS150M150		TDS150M150 TDS150M240	TDS150M240	TDS150M277	TDS150M277 (L-N) SGD125M (N-G)	TDS150M560	

Delta and "S" models are Type 2 devices.

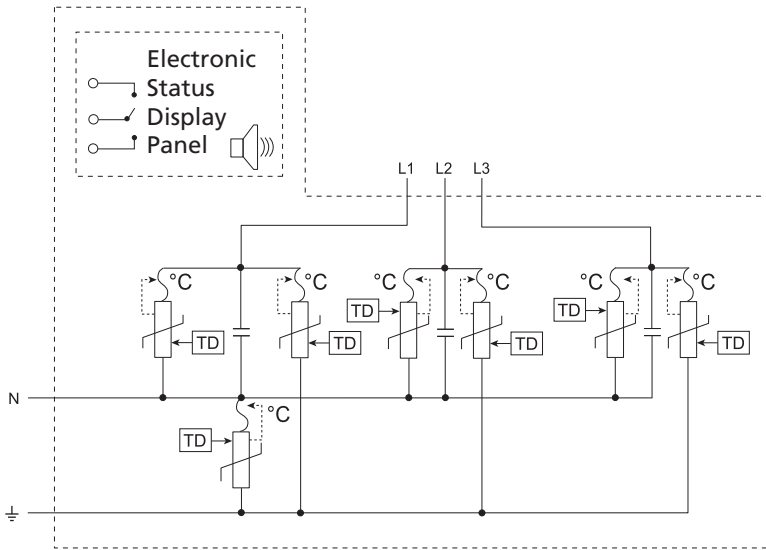

3 Phase WYE Configuration

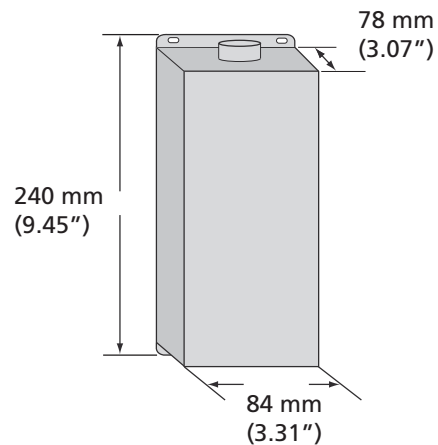

ANSI is a registered trademark of the American National Standards Institute. IEC is a registered trademark of the International Electrotechnical Commission. IEEE is a registered trademark of the Institute of Electrical and Electronics Engineers, Incorporated. NEMA is a registered trademark of the National Electrical Manufacturers Association. UL is a registered certification mark of UL LLC.

TDX200C Transient Discriminating Panel Protection



Features

- Transient Discriminating (TD) Technology provides increased service life
- Built-in features include TD Technology, thermal protection and short circuit current fusing
- Compact NEMA®-4 enclosure design can be flush mounted or installed in a small space
- LED status indication and voltage-free contacts provide remote status monitoring
- 200kA 8/20µs maximum surge rating provides protection suitable for smaller main-distribution panels and an extended operational life
- Available in various operating voltages to suit most common power distribution systems
- CE, UL® 1449 Edition 3 Listed

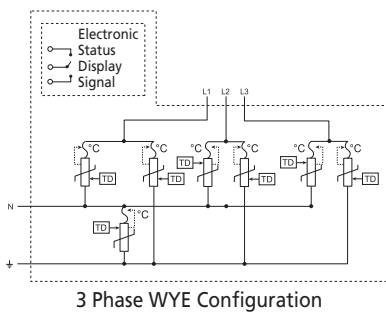

The TDX200 Series of Transient Voltage Surge Suppressors is designed for critical protection applications. The 200kA 8/20µs of surge protection exceeds the IEEE® C62.41.2 Scenario II single shot surge rating requirements for exposed service entrance locations – Exposure 3.

The NEMA-4 weather-tight housing allows the TDX to be installed on indoor or outdoor service panels. The preconfigured connecting leads

simplify installation. The unique narrow construction allows the SPD to fit between adjacent panel boards and connect via a 90-degree elbow. A flush mounting kit is also available for installing the SPD in drywall applications.

Listed as a Type 1 SPD to UL 1449 Edition 3, the TDX200 Series can be installed within a Type 1 or 2 location in accordance with the NEC® 2008

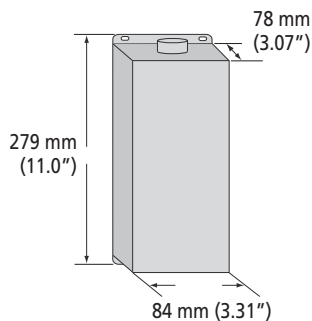

Typical Installation

Model	TDX200C120/208	TDX200C120/240	TDX200C277/480
Nominal Voltage, U _n	120/208 V	120/240 V	277/480 V
Distribution System	3Ph 4W+G	1Ph 3W+G	3Ph 4W+G
Max Cont. Operating Voltage, U _c	170/295 V AC	170/340 V AC	320/536 V AC
Stand-off Voltage	240/415 V	240/480 V	480/831 V
Frequency	50/60 Hz		
Short Circuit Current Rating, I _{sc}	200 kAIC		
Technology	TD Technology with thermal disconnect Over-current Fusing		
Max Discharge Current I _{max}	200 kA 8/20 µs per phase		
Impulse Current, I _{imp}	25 kA 10/350 µs per mode		
Nominal Discharge Current	80 kA 8/20 µs		
Protection Modes	All modes protected via L-N, L-G, & N-G		
Voltage Protection Rating (VPR) (8/20µs)	L-N 800 V @ 3 kA		L-N 1.2 kV @ 3 kA
Status	LED status indication per phase, all modes monitored Remote contacts, change-over, 125 V~ / 3 A, max 1.5 mm ² (#14 AWG) terminals		
Dimensions H x D x W: mm (in)	279 x 78 x 84 (11 x 3.07 x 3.31)		
Weight: kg (lbs)	2.04 (4.50)		
Enclosure	Aluminum, IP 65 (NEMA®-4)		
Connection	Line: 762 mm of 5.26 mm ² (30" of # 10 AWG) flying leads Neutral/Ground: 900 mm of 5.26 mm ² (36" of # 10 AWG) flying leads		
Mounting	3/4" straight nipple		
Temperature	-40°C to 80°C (-40°F to 176°F)		
Approvals	C-Tick, CE, IEC® 61643-1, UL 1449 Edition 3 Listed Type 1/2		
Surge Rated to Meet	ANSI/IEEE® C62.41.2-2002 Cat A, Cat B, Cat C ANSI/IEEE® C62.41.2-2002 Scenario II, Exposure 3, 100 kA 8/20 µs, 10 kA 10/350 µs IEC 61643-1 Class I, Class II UL 1449 Edition 3 In 20 kA mode		
Available Options	Side Mount Kit (Order TDXSM), Flush Mount Kit (Order TDX200CFPP)		

ANSI is a registered trademark of the American National Standards Institute. IEC is a registered trademark of the International Electrotechnical Commission. IEEE is a registered trademark of the Institute of Electrical and Electronics Engineers, Incorporated. NEMA is a registered trademark of the National Electrical Manufacturers Association. UL is a registered certification mark of UL LLC.

TDX100C Transient Discriminating Panel Protection



Features

- Transient Discriminating (TD) Technology provides increased service life
- Built-in features include TD Technology, thermal protection and short circuit current fusing
- Compact NEMA®-4 enclosure design can be flush mounted or installed in a small space
- LED status indication and voltage-free contacts provide remote status monitoring
- 100kA 8/20µs maximum surge rating provides protection suitable for smaller main-distribution panels and an extended operational life
- Available in various operating voltages to suit most common power distribution systems
- CE, UL® 1449 Edition 3 Listed

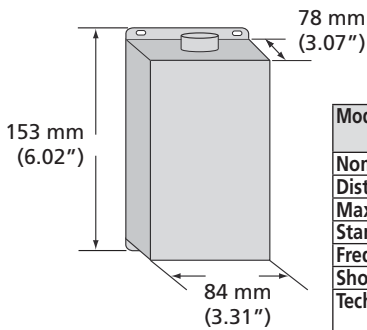
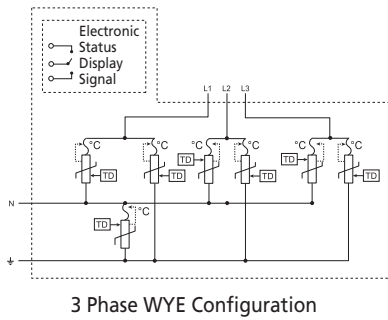

The TDX100 Series of Transient Voltage Surge Suppressors is designed for critical protection applications. The 100kA 8/20µs of surge protection meets the IEEE® C62.41.2 Scenario II single shot surge rating requirements for exposed service entrance locations – Exposure 3.

The NEMA-4 weather tight housing allows the TDX to be installed on indoor or outdoor service panels. The preconfigured connecting leads

simplify installation. The unique narrow construction allows the SPD to fit between adjacent panel boards and connect via a 90-degree elbow. A flush mounting kit is also available for installing the SPD in drywall applications.

Listed as a Type 1 SPD to UL 1449 Edition 3, the TDX100 Series can be installed within a Type 1 or 2 location in accordance with the NEC® 2008



Typical Installation

Model	TDX100C	TDX100C	TDX100C	TDX100C	TDX100C	TDX100C
Nominal Voltage, U _n	120 V	120/208 V	120/240 V	240 V	277/480 V	347/600 V
Distribution System	1Ph 2W+G	3Ph 4W+G	1Ph 3W+G	1Ph 2W+G	3Ph 4W+G	3Ph 4W+G
Max Cont. Operating Voltage, U _c	170 VAC	170/295 VAC	170/340 VAC	275 VAC	320/536 VAC	610/830 VAC
Stand-off Voltage	240 VAC	240/415 VAC	240/480 VAC	480 VAC	480/831 VAC	600/1040 VAC
Frequency	50/60 Hz					
Short Circuit Current Rating, I _{sc}	200 kAIC					
Technology	Over-current Fusing TD Technology with thermal disconnect					
Max Discharge Current, I _{max}	100 kA 8/20 µs per phase					
Impulse Current, I _{imp}	12 kA 10/350 µs per mode					
Nominal Discharge Current, I _n	40 kA 8/20 µs					
Protection Modes	All modes protected via L-N, L-G, & N-G					
Voltage Protection Rating (VPR)	L-N 600 V @ 3 kA 1.2 kV @ 20 kA		L-N 1.0 kV @ 3 kA 1.8 kV @ 20 kA		L-N 1.8 kV @ 3 kA 2.6 kV @ 20 kA	
Status	LED status indication per phase, all modes monitored Remote contacts, change-over, 125 V~ / 3 A, max 1.5 mm ² (#14 AWG) terminals					
Dimensions H x D x W: mm (in)	153 x 78 x 84 (6.02 x 3.07 x 3.31)					
Weight: kg (lbs)	0.80 (1.76)					
Enclosure	Aluminum, IP 65 (NEMA®-4)					
Connection	Line: 762 mm of 5.26 mm ² (30" of # 10 AWG) flying leads Neutral/Ground: 900 mm of 5.26 mm ² (36" of # 10 AWG) flying leads					
Mounting	3/4" straight nipple; Optional flush mounting plate for drywall					
Temperature	-40°C to 80°C (-40°F to 176°F)					
Approvals	C-Tick, CE, IEC® 61643-1, UL 1449 Edition 3 Listed Type 1/2					
Surge Rated to Meet	ANSI®/IEEE® C62.41.2-2002 Cat A, Cat B, Cat C ANSI®/IEEE® C62.41.2-2002 Scenario II, Exposure 3, 100 kA 8/20 µs, 10 kA 10/350 µs IEC 61643-1 Class I, Class II UL 1449 Edition 3 In 20 kA mode					
Available Options	Flush Mount Kit (Order TDXCFP) Side Mount Kit (Order TDXSM)					



ANSI is a registered trademark of the American National Standards Institute. IEC is a registered trademark of the International Electrotechnical Commission. IEEE is a registered trademark of the Institute of Electrical and Electronics Engineers, Incorporated. NEMA is a registered trademark of the National Electrical Manufacturers Association. UL is a registered certification mark of UL LLC.

TDX50C Transient Discriminating Panel Protection



Features

- Transient Discriminating (TD) Technology provides increased service life
- Built-in features include TD Technology, thermal protection and short circuit current fusing
- Compact NEMA®-4 enclosure design can be flush mounted or installed in a small space
- LED status indication and voltage-free contacts provide remote status monitoring
- 50kA 8/20µs maximum surge rating provides protection suitable for sub-distribution panels and a long operational life
- Available in various operating voltages to suit most common power distribution systems
- CE, UL® 1449 Edition 3 Listed

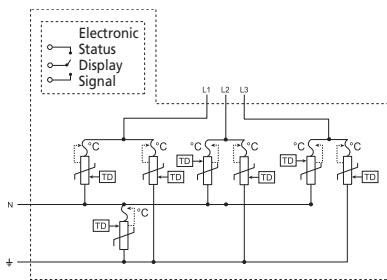

3 Phase WYE Configuration

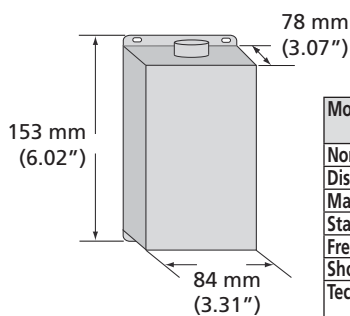

Typical Installation

The TDX50 Series of Transient Voltage Surge Suppressors for equipment, panel and motor protection applications is specifically designed to provide long life, even under the most adverse over-voltage conditions.

The NEMA®-4 weather tight housing allows the TDX to be installed on indoor or outdoor service panels. The preconfigured connecting leads

simplify installation. The unique narrow construction allows the SPD to fit between adjacent panel boards. A flush mounting kit is also available for installing the SPD in drywall applications.

Listed as a Type 1 SPD to UL 1449 Edition 3, the TDX50 Series can be installed within a Type 1 or 2 location in accordance with the NEC® 2008

Model	TDX50C 120	TDX50C 120/208	TDX50C 120/240	TDX50C 120/240D	TDX50C 240	TDX50C 277/480	TDX50C 347/600
Nominal Voltage, U _n	120 V	120/208 V	120/240 V	120/240 V	240 V	277/480 V	347/600 V
Distribution System	1Ph 2W+G	3Ph 4W+G	1Ph 3W+G	3Ph Δ 4W+G	1Ph 2W+G	3Ph 4W+G	3Ph 4W+G
Max Cont. Operating Voltage, U _c	170 VAC	170/295 VAC	170/340 VAC		275 VAC	320/536 VAC	610/830 VAC
Stand-off Voltage	240 VAC	240/415 VAC	240/480 VAC	240/415 VAC	480 VAC	480/831 VAC	600/1040 VAC
Frequency	50/60 Hz						
Short Circuit Current Rating, I _{sc}	200 kAIC						
Technology	Over-current Fusing TD Technology with thermal disconnect						
Max Discharge Current, I _{max}	50 kA 8/20 µs per phase						
Nominal Discharge Current, I _n	20 kA 8/20 µs						
Protection Modes	All modes protected via L-N, L-G, & N-G						
Voltage Protection Rating (VPR)	L-N 600 V @ 3 kA 1.2 kV @ 20 kA		L-N 1.0 kV @ 3 kA 1.8 kV @ 20 kA		L-N 1.8 kV @ 3 kA 2.6 kV @ 20 kA		
Status	LED status indication per phase, all modes monitored Remote contacts, change-over, 125 V- / 3 A, max 1.5 mm ² (#14 AWG) terminals						
Dimensions H x D x W: mm (in)	153 x 78 x 84 (6.02 x 3.07 x 3.31)						
Weight: kg (lbs)	0.70 (1.54)						
Enclosure	Aluminum, IP 65 (NEMA®-4)						
Connection	Line: 762 mm of 5.26 mm ² (30" of # 10 AWG) flying leads Neutral/Ground: 900 mm of 5.26 mm ² (36" of # 10 AWG) flying leads						
Mounting	3/4" straight nipple; Optional flush mounting plate for drywall						
Temperature	-40°C to 80°C (-40°F to 176°F)						
Approvals	C-Tick, CE, IEC® 61643-1, UL 1449 Edition 3 Listed Type 1/2						
Surge Rated to Meet	ANSI®/IEEE® C62.41.2-2002 Cat A, Cat B, Cat C ANSI®/IEEE® C62.41.2-2002 Scenario II, Exposure 2, 50 kA 8/20 µs EC 61643-1 Class II UL 1449 Edition 3 In 10 kA mode						
Available Options	Flush Mount Kit (Order TDXCFP) Side Mount Kit (Order TDXSM)						

ANSI is a registered trademark of the American National Standards Institute. IEC is a registered trademark of the International Electrotechnical Commission. IEEE is a registered trademark of the Institute of Electrical and Electronics Engineers, Incorporated. NEMA is a registered trademark of the National Electrical Manufacturers Association. UL is a registered certification mark of UL LLC.

Transient Discriminating MOVTEC Protection Module



Features

- Primary protection – suitable for high exposure sites and point-of-entry facility protection
- Modular design – allows easy replacement of surge modules
- 5 segment electronic status indication – displays percentage of capacity remaining
- Lug connection – allows Kelvin (in and out) connection of large cables
- Transient Discriminating (TD) Technology – provides increased service life

The Transient Discriminating MOVTEC Protection Module (TDS-MPM) integrates three TDS-MOVTEC units into one enclosure to simplify three phase protection applications.

The TDS-MPM is ideal for primary point-of-entry protection applications where it is connected to the main service panel.

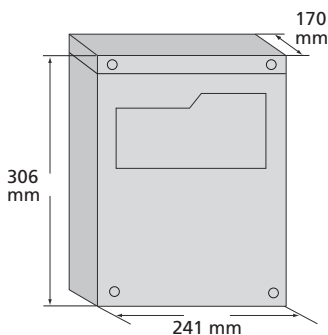
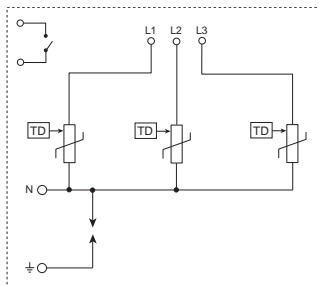
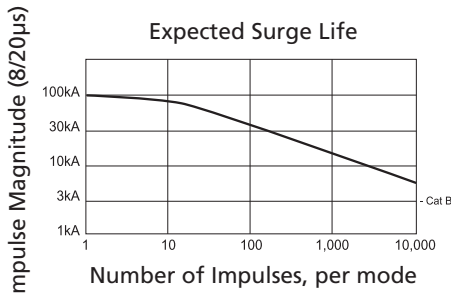

Model	TDSMPM277
Nominal System Voltage, U_n	240/415 V & 277/480 V
Distribution System	3Ph Y 4W+G
System Compatibility	TN-C, TN-S, TN-C-S, TT
Max Cont. Operating Voltage, U_c	400/692 V AC
Stand-off Voltage	440 V N-PE; 480/831 V L-N
Frequency	50/60 Hz
Operating Current @ U_n	25 mA
Aggregate Surge Rating	200 kA 8/20 μ s (L-N)
Max Discharge Current, I_{max}	100 kA 8/20 μ s L-N (NEMA®-LS1) 130 kA 8/20 μ s N-PE (NEMA-LS1)
Nominal Discharge Current, I_n	80 kA 8/20 μ s
Impulse Current, I_{imp}	20 kA 10/350 μ s L-N 50 kA 10/350 μ s L-PE
Protection Modes	All modes protected
Technology	TD Technology and MOV/Silicon L-N Triggered Spark Gap N-PE
Status	(#16 AWG) connecting wire 5 segment LED bar graph per phase Normally open contact, 250 V~/10 A, $\leq 1.5\text{mm}^2$
Dimensions H x D x W: mm (in)	306 x 170 x 241 (12.05 x 6.69 x 9.49)
Weight: kg (lbs)	5 (11)
Enclosure	Metal, IP33 (NEMA-2)
Connection	$\leq 16\text{ mm}^2$ (#6AWG) connecting to M6 bolt
Mounting	Wall mount
Back-up Overcurrent Protection	100 A
Temperature	-35°C to 55°C (-31°F to 131°F)
Approvals	AS3260, C-Tick, IEC® 950
Surge Rated to Meet	ANSI®/IEEE® C62.41.2-2002 Cat A, Cat B, Cat C

Voltage Protection Level, U_p	L-N	N-PE
@Cat B3, 3 kA 8/20 μ s	<750 V	<1.5 kV
@20 kA 8/20 μ s	<980 V	<2.3 kV



Transient Discriminating MOVTEC



Features

- Transient Discriminating (TD) Technology provides increased service life
- Built-in features include TD Technology, thermal protection and short circuit current fusing
- Compact NEMA®-4 enclosure design can be flush mounted or installed in a small space
- LED status indication and voltage-free contacts provide remote status monitoring
- 100kA 8/20µs maximum surge rating provides protection suitable for smaller main-distribution panels and an extended operational life
- Available in various operating voltages to suit most common power distribution systems
- CE, UL® 1449 Edition 3 Listed

The TDS-MOVTEC family of surge diverters offers economical and reliable protection from voltage transients in even the most strenuous applications.

The small footprint provides integrators and OEMs with an effective use of real estate when installing within panels and equipment.

Transient Discriminating (TD) Technology, which meets the UL 1449 Edition 3 standards, provides a superior life by

eliminating the common temporary over-voltage failure mode of most SPDs. TD Technology is essential for any site where abnormal over-voltages can occur or where the possible catastrophic failure of traditional technologies can not be tolerated.

Alarm contacts are provided which may be used to shut down the system or to activate an external warning if the internal surge material is below optimum condition.

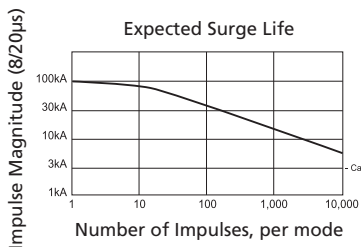
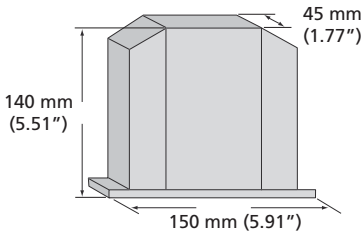

Model	TDSMT120	TDSMT277	TDSMTU277
Nominal Voltage, U_n	110-120 V	230-277 V	230-277 V
System Compatibility	TN-C, TN-S, TN-C-S, IT, TT		
Max Cont. Operating Voltage, U_c	170 VAC	400 VAC	
Stand-off Voltage	240 V	480 V	
Frequency	50/60 Hz		
Operating Current @ U_n	25 mA		
Aggregate Surge Rating	200 kA 8/20 µs		See table
Max Discharge Current, I_{max}	100 kA 8/20 µs		See table
Nominal Discharge Current, I_n	80 kA 8/20 µs		
Impulse Current, I_{imp}	20 kA 10/350 µs		
Protection Modes	Single mode (L-L, L-N, L-G or N-G)		L-G, L-N, N-G
Technology	MOV/Silicon, TD Technology		
Voltage Protection Rating (VPR)	760 V @ 20 kA 400 V @ 3 kA	980 V @ 20 kA 700 V @ 3 kA	See table
Status	5 segment LED bar graph per phase, Normally Open Contact		
Dimensions H x D x W: mm (in)	140 x 45 x 150 (5.51 x 1.77 x 5.91)		
Weight: kg (lbs)	0.6 (1.32)		
Enclosure	UL®94V-0 thermoplastic		
Connection	≤16 mm ² (#6AWG) connecting to M6 bolt		
Back-up Overcurrent Protection	100 A		
Temperature	-35°C to 55°C (-31°F to 131°F)		
Approvals	AS3260, C-Tick, IEC® 950, UL 1449 Edition 3 Recognized Component Type 2		
Surge Rated to Meet	ANSI®/IEEE® C62.41.2-2002 Cat A, Cat B, Cat C ANSI®/IEEE® C62.41.2-2002 Scenario II, Exposure 3, 100 kA 8/20 µs, 10 kA 10/350 µs UL 1449 Edition 3 In 20 kA mode		ANSI®/IEEE® C62.41.2-2002 Cat A, Cat B, Cat C

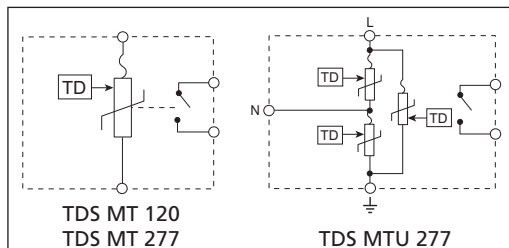

	L-N	L-G	N-G
Aggregate Surge Rating	80 kA	80 kA	40 kA 8/20 µs
Max. Discharge Current, I_{max}	40 kA	40 kA	20 kA 8/20 µs
Voltage Protection Level, U_p			
@500 A 8/20 µs (UL SVR)	700 V	700 V	600 V
@Cat B3, 3 kA 8/20 µs	<750 V	<870 V	<850 V
@20 kA 8/20 µs	<1200 V	<1290 V	<1200 V

ANSI is a registered trademark of the American National Standards Institute. IEC is a registered trademark of the International Electrotechnical Commission. IEEE is a registered trademark of the Institute of Electrical and Electronics Engineers, Incorporated. UL is a registered certification mark of UL LLC.

Triggered Spark Gap



Features

- Triggering air gap technology provides low let-through voltage – offers superior protection compared to traditional spark gaps
- Effective equipotential bonding – provides N-PE equalization protection bond on TT power distribution systems
- Meets IEC 61643-1 test class I, II
- Can be used L-PE, or L-N due to follow current control

The TSG is a vented spark gap with triggering circuit that typically allows let-through voltage of less than 1500V to be achieved. The superior follow current performance allows the TSG to be used on “active”

circuits such as L-L, L-N, L-PE as well as N-PE. The high surge rating is ideal for Neutral-Earth bonding of TT power systems, as per IEC 60364-5-534.

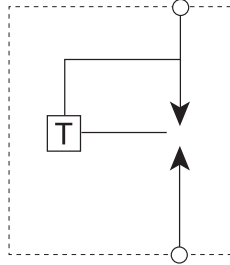
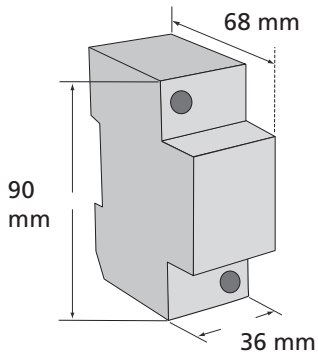

Back-up overcurrent protection for non N-PE applications:

Supply Rating	Minimum Circuit Breaker Rating	Minimum Fuse Rating
500A (<10kAIC)	100A	40A
750A (<15kAIC)	100A	63A
1000A (<20kAIC)	125A	80A
2000A (<43kAIC)	160A	100A

Although the Backup Overcurrent Protection table above indicates minimum values of overcurrent protection to prevent nuisance tripping, it is recommended that the overcurrent protection not exceed 200A Circuit Breaker or a 125A fuse.

Model	TSG11302S	TSG11302S120V
Nominal Voltage, U_n	220 - 240 V	120 V
Distribution System ⁽¹⁾	TN-C, TN-C-S, TN-S, TT	
Max Cont. Operating Voltage U_c	440 VAC	240 VAC
Frequency	50/60 Hz	
Operating Current @ U_n	2.2 mA	
Max Discharge Current, I_{max}	130 kA 8/20 μ s	
Impulse Current, I_{imp}	50 kA 10/350 μ s	
Protection Modes	Single mode (L-L, L-N, L-PE or N-PE)	
Technology	Triggered Spark Gap	
Follow Current Extinguishing Capability	43kA @ U_n	
Voltage Protection Level, U_p	<2.3 kV @ 20 kA <1.5k V @ 3 kA	
Status	LED for Line connected modes	
Dimensions H x D x W: mm (in)	90 x 68 x 36 (3.54 x 2.68 x 1.42)	
Module Width	2 M	
Weight: kg (lbs)	0.3 (0.66)	
Enclosure	DIN 43 880, UL® 94V-0 thermoplastic, IP 20 (NEMA®-1)	
Connection	2.5 mm ² to 50 mm ² (#14AWG to 1/0) or 12 mm x 2.5 mm busbar Bi connect terminal	
Mounting	35 mm top hat DIN rail	
Temperature	-40°C to 80°C (-40°F to 176°F)	
Approvals	C-Tick, CE	
Surge Rated to Meet	ANSI®/IEEE® C62.41.2-2002 Cat A, Cat B, Cat C ANSI®/IEEE® C62.41.2-2002 Scenario II, Exposure 3, 100 kA 8/20 μ s, 10 kA 10/350 μ s	

(1) Should not be connected in all modes of these systems.



Spark Gap Diverter



Features

- Effective equipotential bonding – provides N-E protection bond on TT power distribution systems
- The SGD1100 and SGD125 models meet the IEC 61643-1 test class I and II
- The SGD125 and SGD112 models provide compact modular replaceable units with remote contacts as standard

The SGD1100 spark gap surge diverter has been specifically designed to provide equipotential bonding between the Neutral and Earth terminals of TT power distribution systems, as per IEC 60364-5-534. Its high surge rating makes it suitable to IEC zones 0A-1 and VDE classification B locations.

The SGD112 spark gap surge diverter is a compact modular SPD for applications where the lower surge ratings are acceptable.

The SGD125 spark gap surge diverter is a compact modular SPD for applications where a medium surge rating is required.

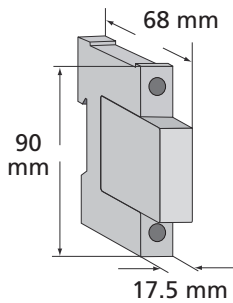

SGD112/125

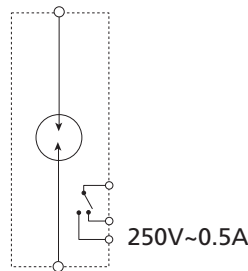

SGD112/125

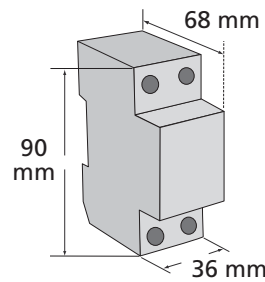

SGD1100

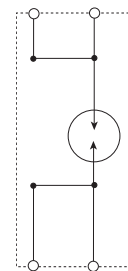

SGD1100

Model	SGD1121SRNE	SGD1251SRNE	SGD11002SNE
Part Number for Europe	702402	702426	702400
System Compatibility	TN-S, TN-C-S, TT for N-PE applications		
Frequency	50/60 Hz		
Operating Current @ U _n	0.50 mA		
Max Discharge Current, I _{max}	40 kA 8/20 μs	60 kA 8/20 μs	140 kA 8/20 μs
Impulse Current, I _{imp}	12 kA 10/350 μs	25 kA 10/350 μs	100 kA 10/350 μs
Protection Modes	N-PE		
Technology	Encapsulated Spark Gap		
Short Circuit Current Rating, I _{sc}	25 kA		
Voltage Protection Level, U _p	1.6 kV @ I _n		1.2 kV @ I _n 0.6 kV @ I _{imp}
Follow Current Extinguishing Capability	100A @ U _n	100A @ U _n	200A @ U _n
Dimensions H x D x W: mm (in)	90 x 68 x 18 (3.54 x 2.68 x 0.69)		90 x 68 x 36 (3.54 x 2.68 x 1.42)
Module Width	1 M		2 M
Weight: kg (lbs)	0.12 (0.26)		0.3 (0.66)
Enclosure	DIN 43 880, UL® 94V-0 thermoplastic, IP 20 (NEMA®-1)		
Connection	≤25 mm ² (#3AWG) stranded ≤35 mm ² (#2AWG) solid		
Mounting	35 mm top hat DIN rail		
Temperature	-40°C to 80°C (-40°F to 176°F)		
Approvals	CE, IEC® 61643-1		
Surge Rated to Meet	ANSI®/IEEE® C62.41.2-2002 Cat A, Cat B, Cat C ANSI®/IEEE® C62.41.2-2002 Scenario II, Exposure 1, 20 kA 8/20 μs, 2 kA 10/350 μs IEC® 61643-1 Class II	ANSI®/IEEE® C62.41.2-2002 Cat A, Cat B, Cat C ANSI®/IEEE® C62.41.2-2002 Scenario II, Exposure 3, 100 kA 8/20 μs, 10 kA 10/350 μs IEC® 61643-1 Class I, Class II	
Replacement Module	SGD112M (702403)	SGD125M (702427)	

(1) Should not be used in all modes of these systems. Refer to reverse side for Power Distribution Systems and SPD Installation.

ANSI is a registered trademark of the American National Standards Institute. IEC is a registered service mark of Independent Electrical Contractors, Inc. IEEE is a registered trademark of the Institute of Electrical and Electronics Engineers, Incorporated. NEMA is a registered trademark of the National Electrical Manufacturers Association. UL is a registered certification mark of UL LLC.

TDS Surge Diverter – TDS130 Series



Features

- TD Technology with thermal disconnect protection
- Compact package, modular DIN rail mounting for limited space requirements
- Three modes of protection: L-N, L-PE & N-PE
- Indication flags and voltage-free contacts provide remote status monitoring
- Separate plug and base design facilitates replacement of a failed surge module
- 15kA 8/20µs surge rating per mode
- CE, UL® 1449 Edition 3 Recognized Component Type 2

Surges and voltage transients are a major cause of expensive electronic equipment failure and business disruption. Damage may result in the loss of capital outlays, such as computers and communications equipment, as well as consequential loss of revenue and profits due to unscheduled system down-time.

The TDS130 series of surge suppressors is designed to provide economical and reliable protection from voltage transients on power distribution systems. The TDS130 is specifically designed for the protection of single phase power supplies within instrumentation and control applications. They are conveniently packaged for easy installation on 35 mm DIN rail within control panels.

Transient Discriminating (TD) technology helps ensure reliable and continued operation during sustained and abnormal over-voltage events. Internal thermal disconnect devices help ensure controlled behavior at end-of-life. A visual indicator flag provides user-feedback in the event of such operation. The TDS130 provides a set of optional voltage-free contacts for remote signaling that maintenance is required.

The convenient plug-in module and separate base design facilitates replacement of a failed surge module without needing to undo installation wiring.

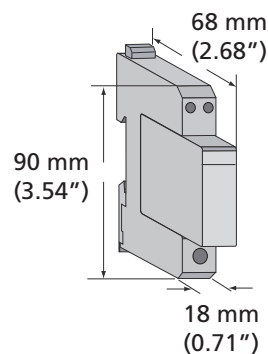

Model	TDS1301TR150	TDS1301T150	TDS1301TR240	TDS1301T240
Item Number for Europe	702421	-	702422	-
Nominal Voltage, U_n	120-150 VAC		220-240 VAC	
Max Cont. Operating Voltage, U_c	170 VAC		275 VAC	
Stand-off Voltage	230 VAC		440 VAC	
Frequency	0-100 Hz			
Nominal Discharge Current, I_n	8 kA 8/20 µs per mode			
Max Discharge Current, I_{max}	15 kA 8/20 µs L-N		15 kA 8/20 µs L-PE	
Protection Modes	L-G, L-N, N-G			
Technology	TD Technology with thermal disconnect			
Short Circuit Current Rating, I_{sc}	200 kAIC			
Back-up Overcurrent Protection	63 AgL, if supply > 63 A			
Voltage Protection Rating (VPR)	500 V @ 3 kA (L+N-G)		800 V @ 3 kA (L+N-G)	
	800 V @ 3 kA (L-N)		1,500 V @ 3 kA (L-N)	
Status	N/O, N/C Change-over contact, 250 V~/0.5 A, max 1.5 mm ² (#14 AWG) terminals Mechanical flag / remote contacts (R model only)			
Dimensions H x D x W: mm (in)	90 x 68 x 18 (3.54 x 2.68 x 0.71)			
Module Width	1 M			
Weight: kg (lbs)	0.12 (0.26)			
Enclosure	DIN 43 880, UL 94V-0 thermoplastic, IP 20 (NEMA®-1)			
Connection	1 mm ² to 6 mm ² (#18AWG to #10AWG) Line and Neutral Terminals ≤25 mm ² (#4AWG) stranded ≤35 mm ² (#2AWG) solid PE Terminal			
Mounting	35 mm top hat DIN rail			
Temperature	-40°C to 80°C (-40°F to 176°F)			
Approvals	CE, IEC® 61643-1, UL 1449 Edition 3 Recognized Component Type 2			
Surge Rated to Meet	ANSI®/IEEE® C62.41.2 Cat A, Cat B IEC 61643-1 Class III UL 1449 Edition 3 In 3 kA mode			
Replacement Module	TDS130M150		TDS130M240	
Replacement Module (Europe)	702432		702424	

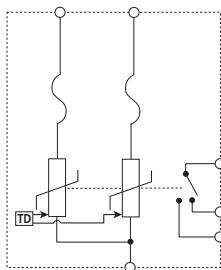

ANSI is a registered trademark of the American National Standards Institute. IEC is a registered trademark of the International Electrotechnical Commission. IEEE is a registered trademark of the Institute of Electrical and Electronics Engineers, Incorporated. NEMA is a registered trademark of the National Electrical Manufacturers Association. UL is a registered certification mark of UL LLC.

TDS Surge Diverter – TDS150 Series



Features

- TD Technology with thermal disconnect protection
- Compact design fits into DIN distribution panel boards and motor control centers
- 35 mm DIN rail mount – DIN 43 880 profile matches common circuit breakers
- Indication flags and voltage-free contacts provide remote status monitoring
- Separate plug and base design facilitates replacement of a failed surge module
- 50kA 8/20 μ s maximum surge rating provides protection suitable for sub-distribution panels and a long operational life
- Available in various operating voltages to suit most common power distribution systems
- CE, UL® 1449 Edition 3 Recognized Component Type 2

Surges and voltage transients are a major cause of expensive electronic equipment failure and business disruption. Damage may result in the loss of capital outlays, such as computers and communications equipment, as well as consequential loss of revenue and profits due to unscheduled system down-time.

The TDS150 series of surge suppressors is designed to provide economical and reliable protection from voltage transients on power distribution systems. They are conveniently packaged for easy installation on 35 mm DIN rail within main distribution panelboards.

Transient Discriminating (TD) technology helps ensure reliable and continued operation during sustained and abnormal over-voltage events. Internal thermal disconnect devices help ensure controlled behavior at end-of-life. A visual indicator flag provides user-feedback in the event of such operation. As standard, the TDS150 provides a set of voltage-free contacts for remote signaling that maintenance is required.

The convenient plug-in module and separate base design facilitates replacement of a failed surge module without needing to undo installation wiring.

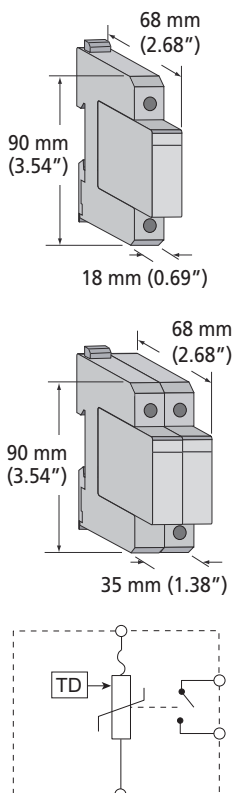

Model	TDS1501SR150	TDS1501SR240	TDS1501SR277	TDS1501SR560	TDS1502BR150	TDS1502BR240
Item Number for Europe	702404	702406	702407	702408	–	–
Nominal Voltage, U_n	120-150 VAC	220-240 VAC	240-277 VAC	480-560 VAC	120-150 VAC	220-240 VAC
Max Cont. Operating Voltage, U_c	170 VAC	275 VAC	320 VAC	610 VAC	170 VAC	275 VAC
Stand-off Voltage	240 VAC	440 VAC	480 VAC	700 VAC	240 VAC	440 VAC
Frequency	0-100 Hz					
Short Circuit Current Rating, I_{sc}	200 kAIC					
Back-up Overcurrent Protection	125 AgL, if supply > 100 A					
Technology	TD Technology with thermal disconnect					
Max Discharge Current, I_{max}	50 kA 8/20 μ s					
Nominal Discharge Current, I_n	25 kA 8/20 μ s	20 kA 8/20			20 kA 8/20 μ s	
Protection Modes	Single mode (L-G, L-N or N-G)				L-N, N-PE	
Voltage Protection Rating (VPR)	400 V @ 3 kA 1.0 kV @ I_n	700 V @ 3 kA 1.2 kV @ I_n	800 V @ 3 kA 1.6 kV @ I_n	1.8 kV @ 3 kA 2.4 kV @ I_n	400 V @ 3 kA 1.0 kV @ I_n	700 V @ 3 kA 1.2 kV @ I_n
Status	N/O, N/C Change-over contact, 250 V-/0.5 A, max 1.5 mm ² (#14 AWG) terminals Mechanical flag / remote contacts (R model only)					
Dimensions H x D x W: mm (in)	90 x 68 x 18 (3.54 x 2.68 x 0.69)					
Module Width	1 M			2M		
Weight: kg (lbs)	0.12 (0.26)			0.24 (0.53)		
Enclosure	DIN 43 880, UL 94V-0 thermoplastic, IP 20 (NEMA®-1)					
Connection	\leq 25 mm ² (#4AWG) stranded \leq 35 mm ² (#2AWG) solid					
Mounting	35 mm top hat DIN rail					
Temperature	-40°C to 80°C (-40°F to 176°F)					
Approvals	CE, IEC® 61643-1, UL 1449 Edition 3 Recognized Component Type 2					
Surge Rated to Meet	ANSI®/IEEE® C62.41.2-2002 Cat A, Cat B, Cat C; ANSI®/IEEE® C62.41.2-2002 Scenario II, Exposure 2, 50 kA 8/20 μ s; 5 kA 10/350 μ s IEC 61643-1 Class II; UL 1449 Edition 3 In 20 kA mode					
Replacement Module	TDS150M150	TDS150M240	TDS150M277	TDS150M560	TDS150M150	TDS150M240

ANSI is a registered trademark of the American National Standards Institute. IEC is a registered service mark of Independent Electrical Contractors, Inc. IEEE is a registered trademark of the Institute of Electrical and Electronics Engineers, Incorporated. NEMA is a registered trademark of the National Electrical Manufacturers Association. UL is a registered certification mark of UL LLC.

TDS Surge Diverter – TDS1100 Series



Features

- TD Technology with thermal disconnect protection
- Compact design fits into DIN distribution panel boards and motor control centers
- 35 mm DIN rail mount – DIN 43 880 profile matches common circuit breakers
- Indication flags and voltage-free contacts provide remote status monitoring
- Separate plug and base design facilitates replacement of a failed surge module
- 100kA 8/20 μ s maximum surge rating provides protection suitable for sub-distribution panels and a long operational life
- Available in various operating voltages to suit most common power distribution systems
- CE, UL® 1449 Edition 3 Recognized Component Type 2

Surges and voltage transients are a major cause of expensive electronic equipment failure and business disruption. Damage may result in the loss of capital outlays, such as computers and communications equipment, as well as consequential loss of revenue and profits due to unscheduled system down-time.

The TDS1100 series of surge suppressors is designed to provide economical and reliable protection from voltage transients on power distribution systems. They are conveniently packaged for easy installation on 35 mm DIN rail within main distribution panelboards.

Transient Discriminating (TD) technology helps ensure reliable and continued operation during sustained and abnormal over-voltage events. Internal thermal disconnect devices help ensure controlled behavior at end-of-life. A visual indicator flag provides user-feedback in the event of such operation. As standard, the TDS1100 provides a set of voltage-free contacts for remote signaling that maintenance is due.

The convenient plug-in module and separate base design facilitates replacement of a failed surge module without needing to undo installation wiring.

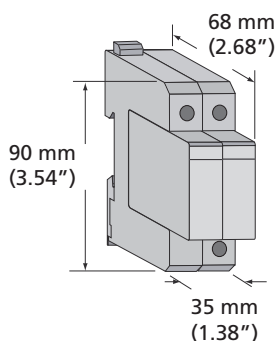

Model	TDS11002SR150	TDS11002SR240	TDS11002SR277	TDS11002SR560
Item Number for Europe	702409	702411	702412	702413
Nominal Voltage, U_n	120-150 VAC	220-240 VAC	240-277 VAC	480-560 VAC
Max Cont. Operating Voltage, U_c	170 VAC	275 VAC	320 VAC	610 VAC
Stand-off Voltage	240 VAC	440 VAC	480 VAC	700 VAC
Frequency	0-100 Hz			
Short Circuit Current Rating, I_{sc}	200 kAIC			
Back-up Overcurrent Protection	125 AgL, if supply > 100 A			
Technology	TD Technology with thermal disconnect			
Max Discharge Current, I_{max}	100 kA 8/20 μ s			
Impulse Current, I_{imp}	12.5 kA 10/350 μ s			
Nominal Discharge Current, I_n	50 kA 8/20 μ s	40 kA 8/20 μ s		
Protection Modes	Single mode (L-G, L-N or N-G)			
Voltage Protection Rating (VPR)	400 V @ 3 kA 1.0 kV @ 20 kA	700 V @ 3 kA 1.2 kV @ 20 kA	800 V @ 3 kA 1.6 kV @ 20 kA	1.8 kV @ 3 kA 2.4 kV @ 20 kA
Status	N/O, N/C Change-over contact, 250 V~/0.5 A, max 1.5 mm ² (#14 AWG) terminals Mechanical flag / remote contacts (R model only)			
Dimensions H x D x W: mm (in)	90 x 68 x 35 (3.54 x 2.68 x 1.38)			
Module Width	2 M			
Weight: kg (lbs)	0.24 (0.53)			
Enclosure	DIN 43 880, UL 94V-0 thermoplastic, IP 20 (NEMA®-1)			
Connection	\leq 25 mm ² (#4AWG) stranded \leq 35 mm ² (#2AWG) solid			
Mounting	35 mm top hat DIN rail			
Temperature	-40°C to 80°C (-40°F to 176°F)			
Approvals	CE, IEC® 61643-1, UL 1449 Edition 3 Recognized Component Type 2			
Surge Rated to Meet	ANSI®/IEEE® C62.41.2-2002 Cat A, Cat B, Cat C ANSI®/IEEE® C62.41.2-2002 Scenario II, Exposure 3, 100 kA 8/20 μ s, 10 kA 10/350 μ s IEC 61643-1 Class I and Class II UL 1449 Edition 3 In 20 kA mode			
Replacement MOV Module	TDS150M150	TDS150M240	TDS150M277	TDS150M560

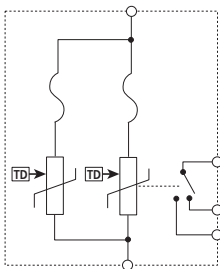

ANSI is a registered trademark of the American National Standards Institute. IEC is a registered trademark of the International Electrotechnical Commission. IEEE is a registered trademark of the Institute of Electrical and Electronics Engineers, Incorporated. NEMA is a registered trademark of the National Electrical Manufacturers Association. UL is a registered certification mark of UL LLC.

TDS Surge Diverter – TDS350 Series

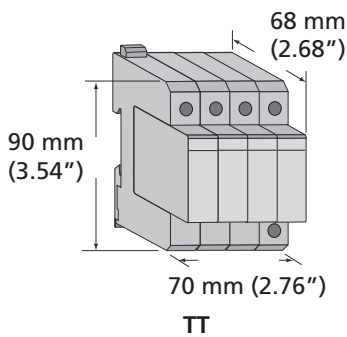
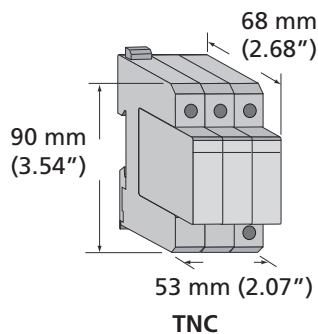

Features

- TD Technology with thermal disconnect protection
- Compact design fits into DIN distribution panel boards and motor control centers
- 35 mm DIN rail mount – DIN 43 880 profile matches common circuit breakers
- Indication flags and voltage-free contacts provide remote status monitoring
- Separate plug and base design facilitates replacement of a failed surge module
- 50kA 8/20 μ s maximum surge rating provides protection suitable for sub-distribution panels and a long operational life
- Available in various operating voltages to suit most common power distribution systems
- CE, UL® 1449 Edition 3 Recognized Component Type 2

Surges and voltage transients are a major cause of expensive electronic equipment failure and business disruption. Damage may result in the loss of capital outlays, such as computers and communications equipment, as well as consequential loss of revenue and profits due to unscheduled system down-time.

Transient Discriminating (TD) technology helps ensure reliable and continued operation during sustained and abnormal over-voltage events.

Internal thermal disconnect devices help ensure controlled behavior at end-of-life. A visual indicator flag provides user-feedback in the event of such operation. As standard, the TDS provides a set of voltage-free contacts for remote signaling that maintenance is due.

The convenient plug-in module and separate base design facilitates replacement of a failed surge module without needing to undo installation wiring.

Model	TDS350TNC150	TDS50120/240	TDS350TNC277	TDS350TNC560	TDS350TT150	TDS350TT277	TDS350TT560
Item Number for Europe	702414	702419	702417		702416	702418	
Nominal Voltage, U_n	120-150 VAC		240-277 VAC	480-560 VAC	120-150 VAC	240-277 VAC	480-560 VAC
Max Cont. Operating Voltage, U_c	170/295 VAC	170/340 VAC	320/536 VAC	610/1055 VAC	170/295 VAC	320/536 VAC	610/1055 VAC
Stand-off Voltage	240/415 VAC	240/480 VAC	480/813 VAC	790/1370 VAC	240/415 VAC	480/813 VAC	790/1370 VAC
Frequency	0-100 Hz						
Short Circuit Current Rating, I_{sc}	200 kAIC						
Back-up Overcurrent Protection	125 AgL, if supply > 100 A						
Technology	TD Technology with thermal disconnect						
Max Discharge Current, I_{max}	50 kA 8/20 μ s				12.5 kA 10/350 μ s N-PE 50 kA 8/20 μ s		
Nominal Discharge Current, I_n	25 kA 8/20 μ s		20 kA 8/20 μ s		25 kA 8/20 μ s		20 kA 8/20 μ s
Protection Modes	L-N	L-N, N-PE	L-N		L-N, N-PE		
Voltage Protection Rating (VPR)	400 V @ 3 kA 1.0 kV @ I_n		800 V @ 3 kA 1.6 kV @ I_n	1.8 kV @ 3 kA 2.4 kV @ 20 kA	400 V @ 3 kA 1.0 kV @ I_n	800 V @ 3 kA 1.6 kV @ I_n	1.8 kV @ 3 kA 2.4 kV @ 20 kA
Status	N/O, N/C Change-over contact, 250 V~/0.5 A, max 1.5 mm ² (#14 AWG) terminals Mechanical flag / remote contacts						
Dimensions H x D x W: mm (in)	90 x 68 x 53 (3.54 x 2.68 x 2.07)				90 x 68 x 70 (3.54 x 2.68 x 2.76)		
Module Width	3 M				4 M		
Weight: kg (lbs)	0.36 (0.79)				0.5 (1.10)		
Enclosure	DIN 43 880, UL® 94V-0 thermoplastic, IP 20 (NEMA®-1)						
Connection	\leq 25 mm ² (#4AWG) stranded \leq 35 mm ² (#2AWG) solid						
Mounting	35 mm top hat DIN rail						
Temperature	-40°C to 80°C (-40°F to 176°F)						
Approvals	CE, IEC® 61643-1, UL 1449 Edition 3 Recognized Component Type 2						
Surge Rated to Meet	ANSI/IEEE® C62.41.2 Cat A, Cat B, Cat C ANSI/IEEE® C62.41.2 Scenario II, Exposure 2, 50 kA 8/20 μ s IEC 61643-1 Class II UL 1449 Edition 3 In 20 kA mode						
Replacement MOV Module	TDS150M150		TDS150M277	TDS150M560	TDS150M150	TDS150M277	TDS150M560
Replacement GDT Module	-				SGD125M		

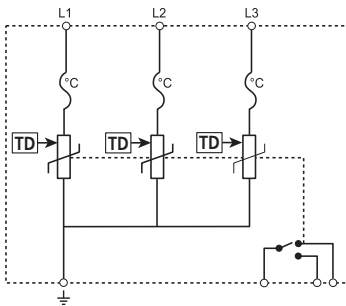

TDS350TNC

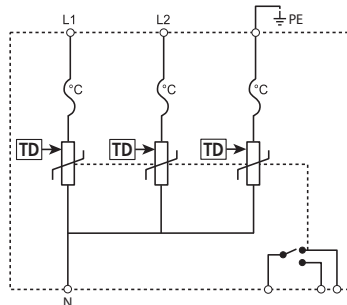

TDS50120/240

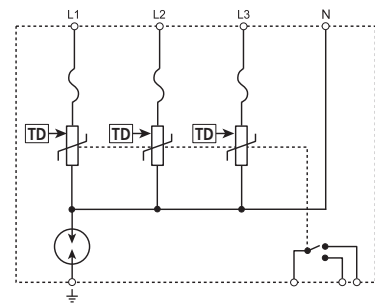

TDS350TT



ANSI is a registered trademark of the American National Standards Institute. IEC is a registered service mark of Independent Electrical Contractors, Inc. IEEE is a registered trademark of the Institute of Electrical and Electronics Engineers, Incorporated. NEMA is a registered trademark of the National Electrical Manufacturers Association. UL is a registered certification mark of UL LLC.

TDS Surge Diverter – Photovoltaic

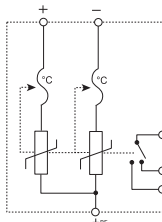
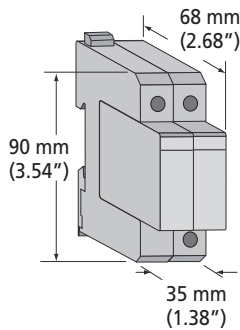

TDS502BR300DC
TDS502BR600DC

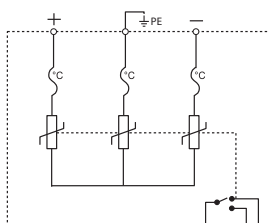
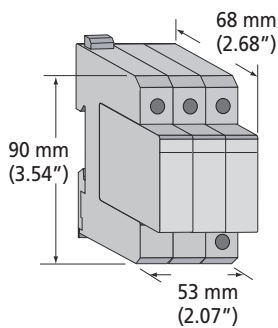

TDS503BR1000DC

Features

- Designed to provide economical and reliable protection from transients on DC power systems
- Compact design fits into inverters and solar combiner boxes
- Conveniently packaged for easy installation on DIN rail
- Provides remote status monitoring
- Designed with thermal disconnect protection
- Separate plug and base design – hot swappable feature allows ease of module replacement
- CE, UL® 1449 Edition 3 for PV applications

Surges and voltage transients are a major cause of equipment failure and system disruption. The TDS50 series surge protective devices, part of the ERITECH® line of facility electrical protection products from ERICO, are designed to provide economical and reliable protection from voltage transients on solar PV systems. They are conveniently packaged for easy installation on 35 mm DIN rail. Internal thermal disconnect devices help ensure

safe behavior at end-of-life. A visual indicator flag provides user feedback in the event of such operation. As standard, the TDS50 provides a set of voltage-free contacts for remote signaling that maintenance is required. The convenient plug-in module and separate base design facilitates replacement of a failed surge module without needing to undo installation wiring.

Model	TDS502BR300DC	TDS502BR600DC	TDS503BR1000DC
Nominal Voltage - DC	350 V	600 V	1,000 V
Max Cont. Operating Voltage, U _c	350 VDC	600 VDC	1,000 VDC
Frequency	0-100 Hz		
Technology	GDT MOV		
Max Discharge Current, I _{max}	50 kA 8/20 μs		
Nominal Discharge Current, I _n	20 kA 8/20 μs		
Protection Modes	L-L, L-PE		
Voltage Protection Rating (VPR)	-/G, +/-G 1,800 V @ 3 kA	-/G, +/-G 2,000 V @ 3 kA	-/G, +/-G 4,000 V @ 3 kA
Status	N/O, N/C Change-over contact, 250 V~/.0.5 A, max 1.5 mm ² (#14 AWG) terminals Mechanical flag / remote contacts		
Dimensions H x D x W: mm (in)	90 x 68 x 35 (3.54 x 2.68 x 1.38)		90 x 68 x 53 (3.54 x 2.68 x 2.07)
Module Width	2 M		3 M
Enclosure	DIN 43 880, UL 94V-0 thermoplastic, IP 20 (NEMA®-1)		
Connection	≤25 mm ² (#4AWG) stranded ≤35 mm ² (#2AWG) solid		
Mounting	35 mm top hat DIN rail		
Temperature	-40°C to 80°C (-40°F to 176°F)		
Approvals	CE, IEC 61643-1, UL® 1449 Edition 3 for PV applications		
Surge Rated to Meet	ANSI®/IEEE® C62.41.2-2002 Cat A, Cat B, Cat C ANSI®/IEEE® C62.41.2-2002 Scenario II, Exposure 2, 50 kA 8/20 μs		
Replacement Module	TDS150M277	TDS150M560	TDS150M277, TDS150M560
Weight: kg (lbs)	0.24 (0.53)	0.24 (0.53)	0.36 (0.78)

ANSI is a registered trademark of the American National Standards Institute. IEC is a registered service mark of Independent Electrical Contractors, Inc. IEEE is a registered trademark of the Institute of Electrical and Electronics Engineers, Incorporated. NEMA is a registered trademark of the National Electrical Manufacturers Association. UL is a registered certification mark of UL LLC.

Dinline Surge Diverter



Features

- 150kA 8/20 μ s surge rating provides protection suitable for main distribution panels and provides a long operational life
- 35 mm DIN 43 880 profile – matches common circuit breakers
- Indication flag – provides clear visual indication of life status
- Remote contacts – provide remote status monitoring
- Various operating voltages – to suit most common power distribution systems*
- Simple combinations of the DSD and SGD series allow the protection of TT, TNC, TNC-S and IT systems

* Other operating voltages may be available upon application.

The DSD1150 series of surge suppressors is designed to provide economical and reliable protection to primary distribution panel boards and power distribution systems. They are intended for locations classified for devices tested to IEC 61643-1 test class I (or VDE classification B). Internal thermal disconnect

devices help ensure safe isolation during sustained and abnormal events on the distribution network, or at end-of-life. A visual indicator flag provides user-feedback in the event of such operation. In addition, a set of voltage-free contacts is provided for remote signaling if replacement is needed.

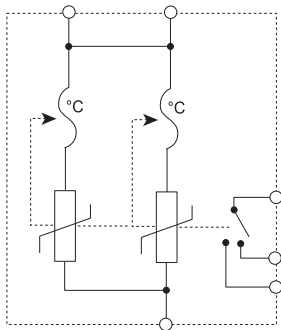
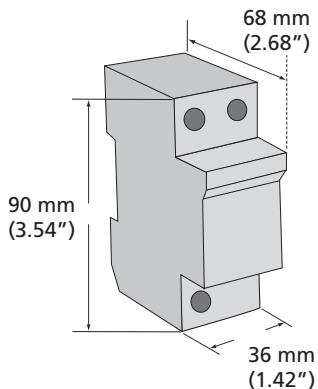

Model	DSD11502SR150	DSD11502SR275
Item Number for Europe	702410	702420
Nominal Voltage, U_n	110-120 V	220-240 V
Distribution System	TN-C, TN-C-S, TN-S, TT	
Max Cont. Operating Voltage, U_c	150 VAC, 200 VDC	275 VAC, 350 VDC
Frequency	0-60 Hz	
Max Discharge Current I_{max}	150 kA 8/20 μ s	
Nominal Discharge Current, I_n	60 kA 8/20 μ s	
Impulse Current, I_{imp}	25 kA 10/350 μ s	
Protection Modes	Single mode	
Technology	MOV with thermal disconnect	
Voltage Protection Level, U_p	480 V @ 3 kA 1.2 kV @ I_n	850 V @ 3 kA 1.6 kV @ I_n
Status	Mechanical flag Change-over contact (Form C dry) 250V~/0.5A, max 1.5 mm ² (#14AWG) connecting wire	
Dimensions H x D x W: mm (in)	90 x 68 x 36 (3.54 x 2.68 x 1.42)	
Module Width	2 M	
Weight: kg (lbs)	0.33 (0.73)	
Enclosure	DIN 43 880, UL [®] 94V-0 thermoplastic, IP 20 (NEMA [®] -1)	
Connection	\leq 25 mm ² (#4AWG) stranded \leq 35 mm ² (#2AWG) solid	
Mounting	35 mm top hat DIN rail	
Back-up Overcurrent Protection	250 Agl if supply >250 A	
Temperature	-40°C to 80°C (-40°F to 176°F)	
Approvals	CE, IEC [®] 61643-1	
Surge Rated to Meet	ANSI [®] /IEEE [®] C62.41.2-2002 Cat A, Cat B, Cat C ANSI [®] /IEEE [®] C62.41.2-2002 Scenario II, Exposure 3, 100 kA 8/20 μ s, 10 kA 10/350 μ s IEC 61643-1 Class I, Class II	



ANSI is a registered trademark of the American National Standards Institute. IEC is a registered trademark of the International Electrotechnical Commission. IEEE is a registered trademark of the Institute of Electrical and Electronics Engineers, Incorporated. NEMA is a registered trademark of the National Electrical Manufacturers Association. UL is a registered certification mark of UL LLC.

Dinline Surge Diverter



Features

- 100kA 8/20 μ s maximum surge rating provides protection suitable for smaller main-distribution panels and an extended operational life
- 35 mm DIN 43 880 profile – matches common circuit breakers
- Indication flag – provides clear visual indication of life status
- Various operating voltages – to suit most common power distribution systems*

* Other operating voltages may be available upon application.

The DSD1100 series of surge suppressors is designed to provide a high surge rating within an economical and reliable product for the protection of sub-distribution panel boards. The convenient compact enclosure provides a high level of protection in the smallest possible housing. Internal thermal disconnect

devices help ensure safe isolation during sustained and abnormal events on the distribution network, or at end-of-life. A visual indicator flag provides user feedback in the event of such operation. They are intended for locations classified for devices tested to IEC 61643-1 test class I.

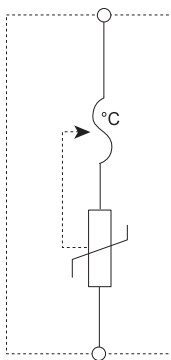
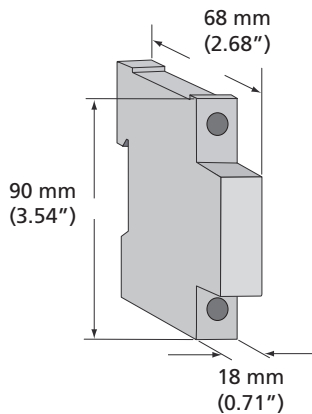

Model	DSD11001S150	DSD11001S275
Item Number for Europe	702430	702440
Nominal Voltage, U_n	110-120 V	220-240 V
Distribution System	TN-C, TN-C-S, TN-S, TT	
Max Cont. Operating Voltage, U_c	150 VAC, 200 VDC	275 VAC, 350 VDC
Frequency	0-60 Hz	
Operating Current @ U_n	1 mA	
Max Discharge Current, I_{max}	100 kA 8/20 μ s	
Nominal Discharge Current, I_n	40 kA 8/20 μ s	
Impulse Current, I_{imp}	12 kA 10/350 μ s	
Protection Modes	Single mode	
Technology	MOV with thermal disconnect	
Short Circuit Current Rating, I_{sc}	25 kAIC	
Voltage Protection Level, U_p	480 V @ 3 kA 1.2 kV @ I_n	850 V @ 3 kA 1.6 kV @ I_n
Status	Mechanical flag	
Dimensions H x D x W: mm (in)	90 x 68 x 18 (3.54 x 2.68 x 0.71)	
Module Width	1 M	
Weight: kg (lbs)	0.12 (0.26)	
Enclosure	DIN 43 880, UL [®] 94V-0 thermoplastic, IP 20 (NEMA [®] -1)	
Connection	≤ 25 mm ² (#4AWG) stranded ≤ 35 mm ² (#2AWG) solid	
Mounting	35 mm top hat DIN rail	
Back-up Overcurrent Protection	160 Agl if supply >160 A	
Temperature	-40°C to 80°C (-40°F to 176°F)	
Approvals	CE, IEC [®] 61643-1	
Surge Rated to Meet	ANSI [®] /IEEE [®] C62.41.2-2002 Cat A, Cat B, Cat C ANSI [®] /IEEE [®] C62.41.2-2002 Scenario II, Exposure 3, 100 kA 8/20 μ s, 10 kA 10/350 μ s IEC [®] 61643-1 Class I, Class II	

ANSI is a registered trademark of the American National Standards Institute. IEC is a registered trademark of the International Electrotechnical Commission. IEEE is a registered trademark of the Institute of Electrical and Electronics Engineers, Incorporated. NEMA is a registered trademark of the National Electrical Manufacturers Association. UL is a registered certification mark of UL LLC.

Dinline Surge Diverter



Features

- 60kA 8/20 μ s maximum surge rating provides protection suitable for sub-distribution panels and a long operational life
- 35 mm DIN 43 880 profile – matches common circuit breakers
- Indication flag – provides clear visual indication of life status
- Remote contacts – provide remote status monitoring
- Various operating voltages – to suit most common power distribution systems*

* Other operating voltages may be available upon application.

The DSD160 series of surge suppressors is designed to provide economical and reliable protection to sub-distribution panel boards. The convenient plug-in module and separate base design facilitates replacement of a failed surge module without needing to undo installation wiring. Internal thermal

disconnect devices help ensure safe isolation during sustained and abnormal events on the distribution network, or at end-of-life. Visual indicator flags show 100% and 50% status with voltage-free contacts to provide user-feedback in the event of reduction of capacity.

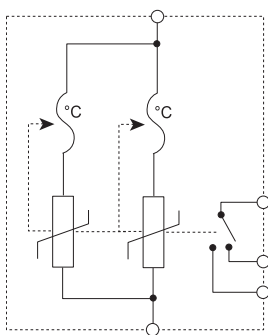
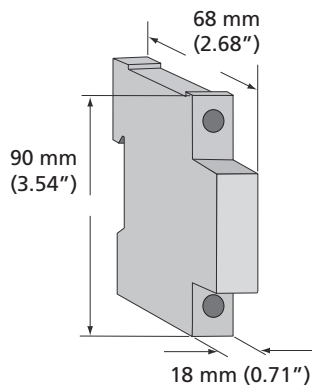

Model	DSD1601SR275
Item Number for Europe	702460
Nominal Voltage, U_n	220-240 V
Distribution System	TN-C, TN-C-S, TN-S, TT
Max Cont. Operating Voltage, U_c	275 VAC, 350 VDC
Frequency	0-60 Hz
Operating Current @ U_n	1 mA
Max Discharge Current, I_{max}	60 kA 8/20 μ s
Nominal Discharge Current, I_n	30 kA 8/20 μ s
Impulse Current, I_{imp}	5 kA 10/350 μ s
Protection Modes	Single mode
Technology	MOV with thermal disconnect
Short Circuit Current Rating, I_{sc}	25 kA
Voltage Protection Level, U_p	850 V @ 3 kA 1.5 kV @ I _n
Status	Mechanical flag with progressive indication Change-over contact (Form C dry) 250V~/0.5A, max 1.5 mm ² (#14AWG) connecting wire
Dimensions H x D x W: mm (in)	90 x 68 x 18 (3.54 x 2.68 x 0.71)
Module Width	1 M
Weight: kg (lbs)	0.12 (0.26)
Enclosure	DIN 43 880, UL [®] 94V-0 thermoplastic, IP 20 (NEMA [®] -1)
Connection	\leq 25 mm ² (#4AWG) stranded \leq 35 mm ² (#2AWG) solid
Mounting	35 mm top hat DIN rail
Back-up Overcurrent Protection	160 Agl if supply >160 A
Temperature	-40°C to 80°C (-40°F to 176°F)
Approvals	CE, IEC [®] 61643-1
Surge Rated to Meet	ANSI [®] /IEEE [®] C62.41.2-2002 Cat A, Cat B, Cat C ANSI [®] /IEEE [®] C62.41.2-2002 Scenario II, Exposure 2, 50 kA 8/20 μ s IEC [®] 61643-1 Class I, Class II
Replacement Module	DSD1601SR275M
Replacement Module (Europe)	702465



ANSI is a registered trademark of the American National Standards Institute. IEC is a registered trademark of the International Electrotechnical Commission. IEEE is a registered trademark of the Institute of Electrical and Electronics Engineers, Incorporated. NEMA is a registered trademark of the National Electrical Manufacturers Association. UL is a registered certification mark of UL LLC.

Dinline Surge Diverter



Features

- 40kA 8/20 μ s maximum surge rating provides protection suitable for sub-distribution panels and a long operational life
- 35 mm DIN 43 880 profile – matches common circuit breakers
- Indication flag – provides clear visual indication of life status
- Remote contacts – provide remote status monitoring
- Various operating voltages – to suit most common power distribution systems

* Other operating voltages may be available upon application.

The DSD140 series of surge suppressors is designed to provide economical protection to sub-distribution panel boards in locations classified for devices tested to IEC 61643-1 test Class II (or VDE classification C). The convenient plug-in module and separate base design facilitates replacement of a failed surge module without needing to undo installation wiring.

A visual indicator flag provides user-feedback if the internal thermal disconnect operates. The “R” series provides a set of voltage-free contacts for remote signaling that maintenance is required.

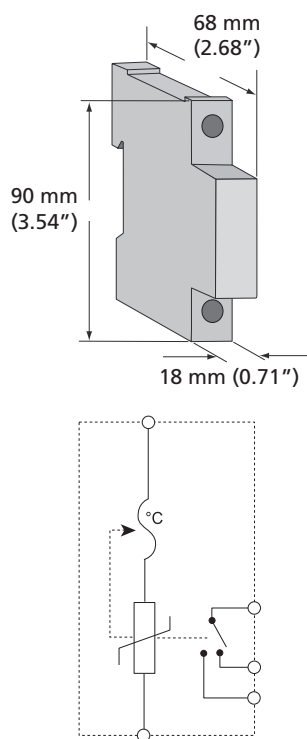

Model	DSD1401S150	DSD1401S275	DSD1401SR150	DSD1401SR275	DSD1401SR440
Item Number for Europe	702480	702491	702510	702521	702530
Nominal Voltage, U _n	110-120 V	220-240 V	110-120 V	220-240 V	380 V
Distribution System	TN-C, TN-C-S, TN-S, TT				
Max Cont. Operating Voltage, U _c	150 VAC 200 VDC	275 VAC 350 VDC	150 VAC 200 VDC	275 VAC 350 VDC	440 VAC 580 VDC
Frequency	0-60 Hz				
Operating Current @ U _n	1 mA				
Max Discharge Current, I _{max}	40 kA 8/20 μ s				
Nominal Discharge Current, I _n	20 kA 8/20 μ s				
Protection Modes	Single mode				
Technology	MOV with thermal disconnect				
Short Circuit Current Rating, I _{sc}	25 kA				
Voltage Protection Level, U _p	480 V @ 3 kA 550 V @ 5kA 0.7 kV @ I _n	850 V @ 3 kA 1 kV @ 5 kA 1.4 kV @ I _n	480 V @ 3 kA 550 V @ 5kA 0.7 kV @ I _n	850 V @ 3 kA 1 kV @ 5 kA 1.4 kV @ I _n	1.4 kV @ 3 kA 1.75 kV @ 5 kA 2.2 kV @ I _n
Status	Mechanical flag		Mechanical flag Change-over contact (Form C dry) 250V~/0.5A, max 1.5 mm ² (#14AWG) connecting wire		
Dimensions H x D x W: mm (in)	90 x 68 x 18 (3.54 x 2.68 x 0.71)				
Module Width	1 M				
Weight: kg (lbs)	0.12 (0.26)				
Enclosure	DIN 43 880, UL [®] 94V-0 thermoplastic, IP 20 (NEMA [®] -1)				
Connection	\leq 25 mm ² (#4AWG) stranded \leq 35 mm ² (#2AWG) solid				
Mounting	35 mm top hat DIN rail				
Back-up Overcurrent Protection	125 Agl if supply >125 A				
Temperature	-40°C to 80°C (-40°F to 176°F)				
Approvals	CE, IEC [®] 61643-1				
Surge Rated to Meet	ANSI/IEEE [®] C62.41.2-2002 Cat A, Cat B, Cat C ANSI/IEEE [®] C62.41.2-2002 Scenario II, Exposure 1, 20 kA 8/20 μ s, 2 kA 10/350 μ s IEC [®] 61643-1 Class II				
Replacement Module	DSD140M150	DSD140M275	DSD140M150	DSD140M275	DSD140M440
Replacement Module (Europe)	702436	702496	702436	702496	702506

ANSI is a registered trademark of the American National Standards Institute. IEC is a registered trademark of the International Electrotechnical Commission. IEEE is a registered trademark of the Institute of Electrical and Electronics Engineers, Incorporated. NEMA is a registered trademark of the National Electrical Manufacturers Association. UL is a registered certification mark of UL LLC.

Dinline Surge Diverter



Features

- 40kA 8/20 μ s maximum surge rating provides protection suitable for sub-distribution panels and a long operational life
- 35 mm DIN 43 880 profile – matches common circuit breakers
- Indication flag – provides clear visual indication of life status
- Remote contacts – provide remote status monitoring
- Various operating voltages – to suit most common power distribution systems

The DSD340 series of surge suppressors is designed to provide economical protection to sub-distribution panel boards in locations classified for devices tested to IEC 61643-1 test Class II (or VDE Classification C). The single module units conveniently protect three phase systems with TNC, TNS and TT options.

A visual indicator flag provides user-feedback if the internal thermal disconnecter operates. The “R” series provides a set of voltage-free contacts for remote signaling that maintenance is required.

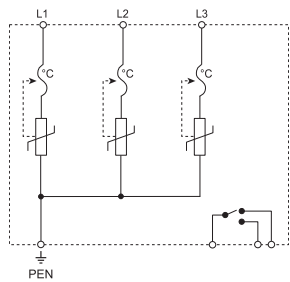

TNC Configuration

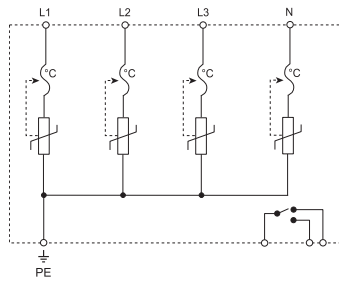

TNS Configuration

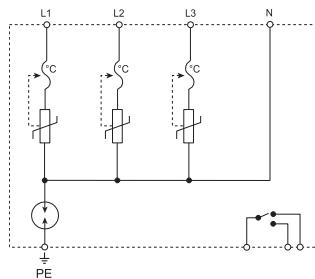

TT Configuration

Model	DSD340TNC275A	DSD340TNS275A	DSD340TT275A
Item Number for Europe	702581	702591	702601
Nominal Voltage, U _n	220/380 V - 240/415 V		
Distribution System	TN-C	TN-S	TT
Max Cont. Operating Voltage, U _c	275 VAC, 350 VDC		
Frequency	0-60 Hz		
Max Discharge Current, I _{max}	40 kA 8/20 μ s		
Nominal Discharge Current, I _n	20 kA 8/20 μ s		
Protection Modes	L-PE	L-PE, N-PE	L-N, N-PE
Technology	MOV (3+0)	MOV (4+0)	MOV GDT N-PE (3+1)
Short Circuit Current Rating, I _{sc}	25 kA		
Impulse Current, I _{imp}	5 kA 10/350 μ s		
Voltage Protection Level, U _p	850 V @ 3 kA 1.4 kV @ I _n	L-PE 850 V @ 3 kA 1.4 kV @ I _n	L-N 850 V @ 3 kA 1.4 kV @ I _n
Status	Mechanical flag Change-over contact (Form C dry) 250V~/0.5A, max 1.5 mm ² (#14AWG) connecting wire		
Dimensions H x D x W: mm (in)	90 x 68 x 54 (3.54 x 2.68 x 2.13)	90 x 68 x 72 (3.54 x 2.68 x 2.83)	
Module Width	3 M	4 M	
Weight: kg (lbs)	0.36 (0.79)	0.50 (1.10)	
Enclosure	DIN 43 880, UL [®] 94V-0 thermoplastic, IP 20 (NEMA [®] -1)		
Connection	\leq 25 mm ² (#4AWG) stranded \leq 35 mm ² (#2AWG) solid		
Mounting	35 mm top hat DIN rail		
Back-up Overcurrent Protection	125 Agl if supply >125 A		
Temperature	-40°C to 80°C (-40°F to 176°F)		
Approvals	CE, IEC [®] 61643-1		
Surge Rated to Meet	ANSI [®] /IEEE [®] C62.41.2-2002 Cat A, Cat B, Cat C ANSI [®] /IEEE [®] C62.41.2-2002 Scenario II, Exposure 2, 20 kA 8/20 μ s, 2 kA 10/350 μ s IEC [®] 61643-1 Class II		
Replacement MOV Module	DSD140M275		
Replacement MOV Module (Europe)	702496		



ANSI is a registered trademark of the American National Standards Institute. IEC is a registered trademark of the International Electrotechnical Commission. IEEE is a registered trademark of the Institute of Electrical and Electronics Engineers, Incorporated. NEMA is a registered trademark of the National Electrical Manufacturers Association. UL is a registered certification mark of UL LLC.

Dinline Surge Diverter



Features

- 15kA 8/20 μ s surge rating per mode
- Compact package, modular DIN rail mounting for limited space requirements
- Three modes of protection: L-N, L-PE & N-PE
- Indication flags and voltage-free contacts provide remote status monitoring
- Separate plug and base design facilitates replacement of a failed surge module

* Other operating voltages may be available upon application.

Surges and voltage transients are a major cause of expensive electronic equipment failure and business disruption. The DSD130 series of surge suppressors is designed to provide economical and reliable protection from voltage transients on power distribution systems. The DSD130 is specifically designed for the protection of single phase power supplies within instrumentation and control applications. They are conveniently packaged for easy

installation on 35mm DIN rail within control panels. Internal thermal disconnect devices help ensure safe disconnection at end-of life. A visual indicator flag provides user-feedback in the event of such operation. The DSD130 provides a set of optional voltage-free contacts for remote signaling that maintenance is required. The convenient plug-in module and separate base design facilitates replacement of a failed surge module without needing to undo installation wiring.

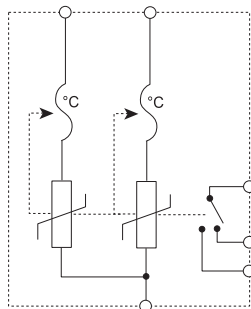
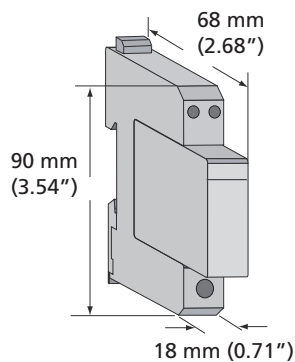

Model	DSD1301BR275
Item Number for Europe	702720
Nominal Voltage, U_n	220-240 V
Distribution System	TN-C, TN-C-S, TN-S, TT
Max Cont. Operating Voltage, U_c	275 VAC, 350 VDC
Frequency	0-100 Hz
Max Discharge Current, I_{max}	15 kA 8/20 μ s L-N 15 kA 8/20 μ s L-PE
Nominal Discharge Current, I_n	8 kA 8/20 μ s per mode
Protection Modes	L-G, L-N, N-G
Technology	MOV with thermal disconnect
Short Circuit Current Rating, I_{sc}	25 kAIC
Voltage Protection Level, U_p	800 V @ 3 kA (L+N-G) 1,500 V @ 3 kA (L-N)
Status	Mechanical flag / remote contacts N/O, N/C Change-over contact, 250 V~/0.5 A, max 1.5 mm ² (#14 AWG) terminals
Dimensions H x D x W: mm (in)	90 x 68 x 18 (3.54 x 2.68 x 0.71)
Module Width	1 M
Weight: kg (lbs)	0.12 (0.26)
Enclosure	DIN 43 880, UL [®] 94V-0 thermoplastic, IP 20 (NEMA [®] -1)
Connection	1 mm ² to 6 mm ² (#18AWG to #10AWG) Line and Neutral Terminals \leq 25 mm ² (#4AWG) stranded \leq 35 mm ² (#2AWG) solid PE Terminal
Mounting	35 mm top hat DIN rail
Back-up Overcurrent Protection	63 AgL, if supply > 63 A
Temperature	-40°C to 80°C (-40°F to 176°F)
Approvals	CE, IEC [®] 61643-1
Surge Rated to Meet	ANSI [®] /IEEE [®] C62.41.2 Cat A, Cat B IEC [®] 61643-1 Class III
Replacement Module	DSD130M275
Replacement Module (Europe)	-

ANSI is a registered trademark of the American National Standards Institute. IEC is a registered trademark of the International Electrotechnical Commission. IEEE is a registered trademark of the Institute of Electrical and Electronics Engineers, Incorporated. NEMA is a registered trademark of the National Electrical Manufacturers Association. UL is a registered certification mark of UL LLC.

Dinline Surge Diverter

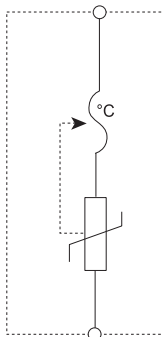
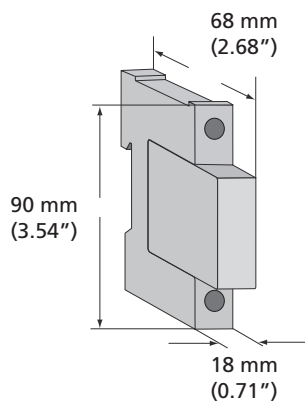

Features

- 10kA 8/20 μ s maximum surge rating – provides protection suitable for small sub-distribution panels or point-of-use applications
- 35 mm DIN 43 880 profile – matches common circuit breakers
- Indication flag – provides clear visual indication of life status
- Various operating voltages – to suit most common power distribution systems*

* Other operating voltages may be available upon application.

The DSD110 series of surge suppressors is designed to provide economical protection to small sub-distribution panel boards or locations classified for devices tested to IEC 61643-1 test Class II or III (or VDE classification D). They are also ideal for the installation in wiring termination boxes at the equipment's final point-of-use.

Model	DSD110S275
Item Number for Europe	702560
Nominal Voltage, U_n	220-240 V
Distribution System	TN-C, TN-C-S, TN-S, TT
Max Cont. Operating Voltage, U_c	275 VAC, 350 VDC
Frequency	0-60 Hz
Max Discharge Current, I_{max}	10 kA 8/20 μ s
Nominal Discharge Current, I_n	5 kA 8/20 μ s
Protection Modes	Single mode
Technology	MOV with thermal disconnect
Short Circuit Current Rating, I_{sc}	25 kA
Voltage Protection Level, U_p	930 V @ 3kA 1.0 kV @ I_n
Status	Mechanical flag
Dimensions H x D x W: mm (in)	90 x 68 x 18 (3.54 x 2.68 x 0.71)
Module Width	1 M
Weight: kg (lbs)	0.12 (0.26)
Enclosure	DIN 43 880, UL® 94V-0 thermoplastic, IP 20 (NEMA®-1)
Connection	≤ 25 mm ² (#4AWG) stranded ≤ 35 mm ² (#2AWG) solid
Mounting	35 mm top hat DIN rail
Back-up Overcurrent Protection	100 Agl if supply >100 A
Temperature	-40°C to 80°C (-40°F to 176°F)
Approvals	CE, IEC® 61643-1
Surge Rated to Meet	ANSI®/IEEE® C62.41.2 Cat A, Cat B IEC® 61643-1 Class III
Replacement Module	DSD110M275
Replacement Module (Europe)	702566

Dinline Surge Diverter



Features

- 40kA 8/20µs surge rating – suitable for exposed DC wiring
- 35 mm DIN 43 880 profile – matches common circuit breakers
- Indication flag – provides clear visual indication of life status
- Suitable for both 24VDC and 48VDC distribution systems

The DSD140 2BR 24/48 surge protection device is designed to provide economical and reliable protection to DC power systems used in such applications as photovoltaic and telepower distribution. It is intended for locations classified for devices tested to IEC 61643-1 test Class II (or VDE Classification C). Internal thermal disconnect devices help ensure safe isolation at end-of-life. A visual indication flag provides user feedback in the event of such operation. In addition, a set of voltage-free contacts is provided for remote signaling if replacement is required.

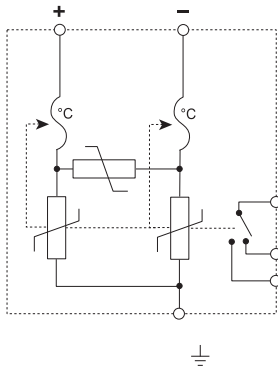
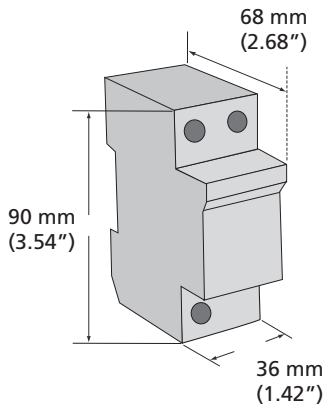

Model	DSD1402BR24/48
Item Number for Europe	702750
Nominal Voltage, U_n	0 to 48 VDC
Max Cont. Operating Voltage, U_c	60 VAC & 60 VDC
Frequency	0-60 Hz
Max Discharge Current, I_{max}	40 kA 8/20 µs
Impulse Current, I_{imp}	4.2 kA 10/350 µs per mode
Nominal Discharge Current, I_n	20 kA 8/20 µs
Protection Modes	Differential & Common Mode
Technology	MOV with thermal disconnect
Short Circuit Current Rating, I_{sc}	25 kA
Voltage Protection Level, U_p	280 V @ 3 kA L-N 600 V @ I_n + to -
Status	Mechanical flag Change-over contact (Form C Dry) 250 V---/0.5 A, max 1.5 mm ² (#14 AWG) connecting wire
Dimensions H x D x W: mm (in)	90 x 68 x 36 (3.54 x 2.68 x 1.42)
Module Width	2 M
Weight: kg (lbs)	0.15 (0.33)
Enclosure	DIN 43 880, UL® 94V-0 thermoplastic, IP 20 (NEMA®-1)
Connection	≤25 mm ² (#4AWG) stranded ≤35 mm ² (#2AWG) solid
Mounting	35 mm top hat DIN rail
Back-up Overcurrent Protection	250 Agl if supply >250 A
Temperature	-40°C to 80°C (-40°F to 176°F)
Approvals	CE, IEC® 61643-1
Surge Rated to Meet	ANSI®/IEEE® C62.41.2-2002 Cat A, Cat B, Cat C ANSI®/IEEE® C62.41.2-2002 Scenario II, Exposure 1, 20 kA 8/20 µs, 2 kA 10/350 µs IEC® 61643-1 Class II

Dinline Surge Diverter



Features

- Ease of grounding – through DIN mounting rail or via terminal
- General purpose barrier – protection of 12 / 24V DC systems and equipment
- Large surge rating to 20kA 8/20 μ s – suitable for exposed DC wiring
- Separate plug and base design – facilitates ease of module replacement
- Two stage protection – suitable for the protection of power supply feeds
- High series current rating of 10A

The DSD120 series is designed to provide protection for higher load current circuits that are exposed to higher transient levels, such as those which exit the facility building. The DSD120 series provides a high series current rating of 10A, making it especially useful on power supply circuits and higher current relay control circuits.

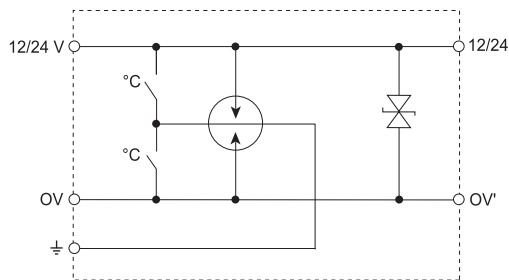
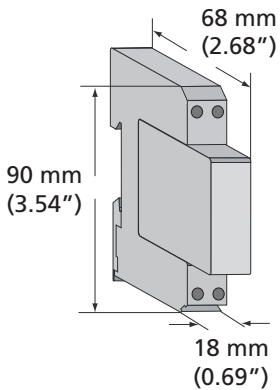

Model	DSD1201S12	DSD1201S24
Item Number for Europe	702670	702680
Nominal System Voltage, U_n	12 VDC	24 VDC
Max Cont. Operating Voltage, U_c	24 VDC	28 VDC
Max Line Current, I_L	10 A	
Max Discharge Current, I_{max}	20 kA 8/20 μ s (L+L)-PE	
Protection Modes	Differential & Common Mode	
Technology	GDT Silicon	
Voltage Protection Level	L-L 30 V @ 3 kA	L-L 40 V @ 3 kA
Loop Resistance	0.5 Ω	
Dimensions H x D x W: mm (in)	90 x 68 x 18 (3.54 x 2.68 x 0.69)	
Module Width	1 M	
Weight: kg (lbs)	0.1 (0.22)	
Enclosure	DIN 43 880, UL® 94V-0 thermoplastic, IP 20 (NEMA®-1)	
Connection	1 mm ² to 6 mm ² (#18AWG to #10AWG) Grounding via terminal or DIN rail connection	
Mounting	35 mm top hat DIN rail	
Temperature	-25°C to 70°C (-13°F to 158°F)	
Approvals	CE	
Surge Rated to Meet	ANSI®/IEEE® C62.41.2-2002 Cat A, Cat B, Cat C	
Replacement Module	DSD1201S12M	DSD1201S24M
Replacement Module (Europe)	(702675)	(702685)



ANSI is a registered trademark of the American National Standards Institute. IEEE is a registered trademark of the Institute of Electrical and Electronics Engineers, Incorporated. NEMA is a registered trademark of the National Electrical Manufacturers Association. UL is a registered certification mark of UL LLC.

Dinline Surge Filter

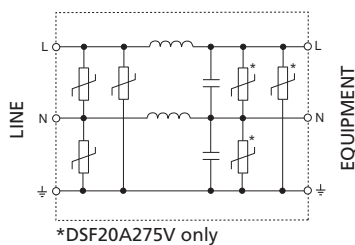
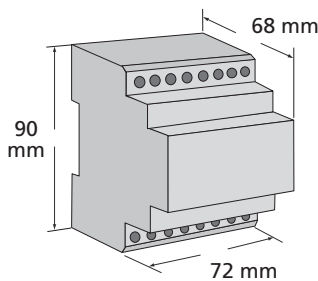
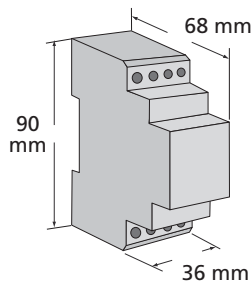

Features

- In-line series protection
- EMI/RFI noise filtering – protects against industrial electrical noise
- Compact design – fits into motor control and equipment panels
- Three modes of protection: L-N, L-PE & N-PE
- 35 mm DIN rail mount – simple installation
- LED power indicator

The “two port” DSF series has been specifically designed for process control applications to protect the switched mode power supply units on devices such as PLC controllers, SCADA systems and motor controllers. The 30V unit is suitable for 12V and 24VAC/DC signaling and control systems.

The 6A DSF series incorporates a space efficient, low pass, series filter which provides attenuation to high frequency interference. The larger 20A model provides status indication and a higher surge rating, making this ideal for the protection of higher risk equipment.

Model	DSF6A30V	DSF6A150V	DSF6A275V	DSF20A275V
Item Number for Europe	702090	701000	701030	701020
Nominal Voltage, U _n	24 V	110 V-120 V	220 V-240 V	
Distribution System	1Ph 2W+G			
System Compatibility	TN-S, TN-C-S			
Max Cont. Operating Voltage, U _c	30 VAC, 38 VDC	150 VAC	275 VAC	
Frequency	0-60 Hz	50/60 Hz		
Max Line Current, I _l	6 A			20 A
Operating Current @ U _n	7 mA			-
Max Discharge Current, I _{max}	4 kA 8/20 per mode	16 kA 8/20 per mode		15 kA 8/20 μs L-N 15 kA 8/20 μs L-PE 25 kA 8/20 μs N-PE
Protection Modes	All modes protected			
Technology	In-line series filter MOV			
Voltage Protection Level, U _p	110 V @ 3 kA	400 V @ 3 kA	750 V @ 3 kA	710 V @ 3 kA
Filtering	-3 dB @ 300 kHz			-3 dB @ 62 kHz
Status	LED power indicator			Status indicator
Dimensions H x D x W: mm (in)	90 x 68 x 36 (3.54 x 2.68 x 1.42)			90 x 68 x 72 (3.54 x 2.68 x 2.83)
Module Width	2 M			4 M
Weight: kg (lbs)	0.2 (0.44)			0.7 (1.54)
Enclosure	DIN 43 880, UL® 94V-0 thermoplastic, IP 20 (NEMA®-1)			
Connection	1 mm ² to 6 mm ² (#18AWG to #10AWG)			
Mounting	35 mm top hat DIN rail			
Back-up Overcurrent Protection	6 A			20 A
Temperature	-35°C to 55°C (-31°F to 131°F)			
Approvals	C-Tick, CE, NOM, UL 1449 Edition 3 Recognized Component Type 2		C-Tick, CE	
Surge Rated to Meet	ANSI®/IEEE® C62.41.2 Cat A, Cat B			

ANSI is a registered trademark of the American National Standards Institute. IEEE is a registered trademark of the Institute of Electrical and Electronics Engineers, Incorporated. NEMA is a registered trademark of the National Electrical Manufacturers Association. UL is a registered certification mark of UL LLC.

Transient Discriminating Filter



Features

- Transient Discriminating (TD) Technology provides increased service life
- In-line series protection
- High efficiency low pass sine wave filtering – ideal for the protection of switched mode power supplies
- Three modes of protection: L-N, L-PE & N-PE
- 35 mm DIN rail mount – simple installation
- LED status indication and opto-isolated output – for remote status monitoring
- CE, UL® 1449 Edition 3 Listed

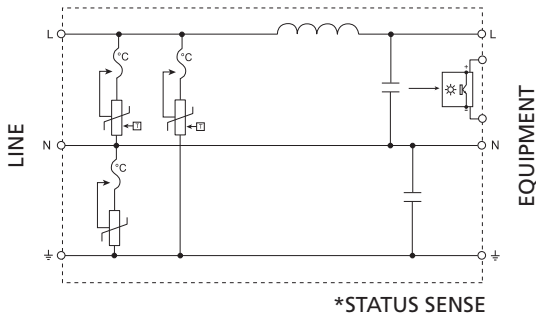

The TDF series has been specifically designed for process control applications to protect the switched mode power supply units on devices such as PLC controllers, SCADA systems and motor controllers. Units are UL Recognized and available for 3A, 10A and 20A loads and suitable for 110-120VAC/DC and 220-240VAC circuits.

The TDF is a series connected, single phase surge filter providing an aggregate surge capacity of 50kA (8/20 μ s) across L-N, L-PE, and N-PE. The low pass filter provides up to 65dB of attenuation to voltage transients. Not only does this reduce the residual let-through voltage, but it also helps further reduce the steep voltage rate-of-rise providing superior protection for sensitive electronic equipment.

Model	TDF3A120V	TDF3A240V	TDF10A120V	TDF10A240V	TDF20A120V	TDF20A240V
Item Number for Europe	700001	700002	700003	700004	700005	700006
Nominal Voltage, U _n	110-120 V	220-240 V	110-120 V	220-240 V	110-120 V	220-240 V
Distribution System	TN-C-S, TN-S					
Max Cont. Operating Voltage, U _c	170 V AC	340 V AC	170 V AC	340 V AC	170 V AC	340 V AC
Stand-off Voltage	240 V	400 V	240 V	400 V	240 V	400 V
Frequency	0-60 Hz	50/60 Hz	0-60 Hz			50/60 Hz
Max Line Current, I _l	3 A		10 A		20 A	
Operating Current @ U _n	135 mA	250 mA	240 mA	480 mA	240 mA	480 mA
Max Discharge Current, I _{max}	10 kA 8/20 μs N-PE 20 kA 8/20 μs L-N 20 kA 8/20 μs L-PE					
Protection Modes	All modes protected					
Technology	In-line series low pass sine wave filter TD Technology					
Voltage Protection Rating (VPR)	500 V @ 500 A 330 V @ 3 kA	700 V @ 500 A 600 V @ 3 kA	500 V @ 500 A 330 V @ 3 kA	700 V @ 500 A 500 V @ 3 kA	500 V @ 500 A 400 V @ 3 kA	700 V @ 500 A 900 V @ 3 kA
Filtering	-62 dB @ 100 kHz		-65 dB @ 100 kHz		-53 dB @ 100 kHz	
Status ⁽¹⁾	Green LED. On=Ok. Isolated opto-coupler output					
Dimensions H x D x W: mm (in)	90 x 68 x 72 (3.54 x 2.68 x 2.83)		90 x 68 x 144 (3.54 x 2.68 x 5.67)			
Module Width	4 M		8 M			
Weight: kg (lbs)	0.7 (1.54)		1.48 (3.25)		1.57 (3.46)	
Enclosure	DIN 43 880, UL® 94V-0 thermoplastic, IP 20 (NEMA®-1)					
Connection	1 mm ² to 6 mm ² (#18AWG to #10)					
Mounting	35 mm top hat DIN rail					
Back-up Overcurrent Protection	3 A		10 A		20 A	
Temperature	-35°C to 55°C (-31°F to 131°F)					
Approvals	C-Tick, CE (NOM 3A, 120V), CSA 22.2, UL 1283, UL 1449 Edition 3 Recognized Component Type 2					
Surge Rated to Meet	ANSI®/IEEE® C62.41.2 Cat A, Cat B, Cat C					

(1) Opto-coupler output can be connected to DINLINE Alarm Relay (DAR275V) to provide Form C dry contacts.

Triggered Spark Gap Surge Reduction Filter



Backplane version available upon request.

Features

- Incorporates TSG and TD Technologies – high performance protection
- High surge rating – ideal for exposed critical service entrance applications
- Surge Reduction Filters dramatically reduce let-through voltage – provides optimum protection
- Surge Reduction Filters reduce rate-of-voltage rise (dv/dt) – improved protection for electronic equipment
- Small size/weight – aids installation
- Escutcheon panel – improved safety

Triggered Spark Gap Surge Reduction Filters are designed to provide high-energy surge diversion, making them ideal for primary service protection applications. The units also provide efficient low pass filtering to substantially reduce the risk of physical equipment damage by reducing the rate-of-voltage rise.

The high energy diversion ability of the spark gap has allowed the size and weight of the units to be considerably reduced.

Single Phase

Model	TSG-SRF140	TSG-SRF163	TSG-SRF1125
Nominal Voltage, U_n	220-240 V		
Distribution System	1Ph 2W+G		
System Compatibility	TN-C, TN-S, TT		
Max Cont. Operating Voltage, U_c	275 V AC		
Stand-off Voltage	440 V		
Frequency	50/60 Hz		
Max Line Current, I_L	40 A	63 A	125 A
Max Discharge Current I_{max}	130 kA 8/20 μ s (NEMA-LS1 per mode)		
Impulse Current, I_{imp}	50 kA 10/350 μ s		
Protection Modes	All modes protected		
Technology	Triggered Spark Gap In-line series, true L-C low pass sine wave tracking filter 40kA 8/20 μ s tertiary TD Technology		
Voltage Protection Level, U_p	L-N 210 V @ 3 kA 180 V @ 20 kA	L-N 262 V @ 3 kA 247 V @ 20 kA	L-N 413 V @ 3 kA 392 V @ 20 kA
Filtering	-40 dB @ 100 kHz		
Status	Change-over contact (Form C dry), 125V/~600mA. 4kV isolation Primary Protection LED Tertiary Protection LED		
Dimensions H x D x W: mm (in)	400 x 170 x 300 (16 x 7 x 12)		
Weight: kg (lbs)	11 (24)		13 (29)
Enclosure	Metal, IP55 (NEMA®-12)		
Heat Dissipation @ I_L	13 W		19 W
Connection Input	\leq 50 mm ² (1/0 AWG)		8 mm stud
Connection Output	\leq 35 mm ² (#2 AWG)		8 mm stud
Mounting	Wall mount		
Back-up Overcurrent Protection	See Table		125 A
Approvals	AS3100, C-Tick, Certificate of Suitability		
Surge Rated to Meet	ANSI®/IEEE® C62.41.2-2002 Cat A, Cat B, Cat C ANSI®/IEEE® C62.41.2-2002 Scenario II, Exposure 3, 100 kA 8/20 μ s, 10 kA 10/350 μ s		



Single Phase

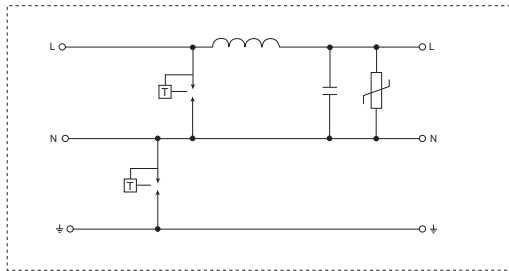

Three Phase

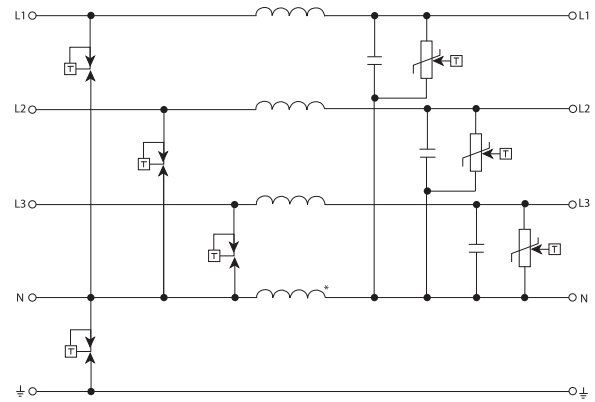

* Neutral inductor omitted in 40A and 63A models

Back-up overcurrent protection for 40A and 63A rated units:

Supply Rating	Min. Circuit Breaker Rating	Min. Fuse Rating
500 A (<10 kAIC)	100 A	40 A
750 A (<15 kAIC)	100 A	63 A
1000 A (<20 kAIC)	125 A	80 A
2000 A (<43 kAIC)	160 A	100 A

Three Phase

Model	TSG-SRF340	TSG-SRF363	TSG-SRF3125	TSG-SRF3200	TSG-SRF3400	TSGSRF3630	TSG-SRF31250	TSG-SRF32000
Nominal Voltage, U_n	220/480 VAC to 240/415 VAC							
Distribution System	3Ph Y 4W+G							
System Compatibility	TN-C, TN-S, TN-C-S, TT							
Max Cont. Operating Voltage, U_c	275/476 VAC							
Stand-off Voltage	440/762 VAC							
Frequency	50/60 Hz							
Max Line Current, I_L	40 A	63 A	125 A	200 A	400 A	630 A	1,250 A	2,000 A
Max Discharge Current I_{max}	130 kA 8/20 μ s (NEMA-LS1 per mode)							
Impulse Current, I_{imp}	50 kA 10/350 μ s							
Protection Modes	All modes protected							
Technology	Triggered Spark Gap In-line series, true L-C low pass sine wave tracking filter 40kA 8/20 μ s tertiary TD Technology					Triggered Spark Gap In-line series, true L-C low pass sine wave tracking filter 80kA 8/20 μ s tertiary TD Technology		
Voltage Protection Level, U_p	L-N 210 V @ 3 kA 180 V @ 20 kA	L-N 352 V @ 3 kA 282 V @ 20 kA	L-N 325 V @ 3 kA 404 V @ 20 kA	L-N 347 V @ 3 kA 447 V @ 20 kA	L-N 500 V @ 3 kA 500 V @ 20 kA			
Filtering	-40 dB @ 100 kHz							
Status	Change-over contact (Form C dry), 125V/-600mA. 4kV isolation Primary Protection LED Tertiary Protection LED							
Dimensions H x D x W: mm (in)	500 x 170 x 400 (19.7 x 6.7 x 15.8)		650 x 175 x 500 (25.6 x 6.9 x 19.7)	780 x 215 x 500 (30.7 x 8.5 x 19.7)	1,100 x 233 x 650 (43.3 x 9.2 x 25.6)	1,300 x 235 x 850 (51.2 x 9.3 x 33.5)	1,650 x 315 x 1,200 (65 x 12.4 x 47.2)	
Weight: kg (lbs)	20 (44)		38 (84)	52 (115)	98 (216)	115 (254)	288 (635)	360 (794)
Enclosure	Metal, IP55 (NEMA®-12)					IP32		
Heat Dissipation @ I_L	29 W	36 W	63 W	90 W	175 W	225 W	350 W	600 W
Connection Input	\leq 50 mm ² (1/0 AWG)		8 mm stud	10 mm stud	Inquire			Inquire
Connection Output	\leq 35 mm ² (#2 AWG)		8 mm stud	10 mm stud	Inquire			Inquire
Mounting	Wall mount							
Back-up Overcurrent Protection	See Table		125 A	200 A	400 A	630 A	1250 A	2000 A
Approvals	A53100, C-Tick, Certificate of Suitability							
Surge Rated to Meet	ANSI®/IEEE® C62.41.2-2002 Cat A, Cat B, Cat C ANSI®/IEEE® C62.41.2-2002 Scenario II, Exposure 3, 100 kA 8/20 μ s, 10 kA 10/350 μ s							

Universal Transient Barrier Single Pair



Features

- General purpose barrier – protection of low-voltage circuits and transducers
- Separate plug and base design – hot swappable feature allows ease of module replacement
- Multi stage protection – fine over-voltage protection, helps ensure lowest residual surge voltages reach sensitive equipment
- Common-mode and differential-mode protection – protects against both possible surge conditions
- Ease of grounding – through DIN mounting rail or via terminal
- Surge rating to 20 kA 8/20 μ s – ideal for exposed wiring
- Allows for protection of 25 analog signals or 50 digital signals per linear foot of DIN rail space

The UTB series is designed to provide transient protection for equipment from surges induced onto balanced pair signal lines. They are well suited to the protection of industrial equipment such as PLCs and SCADA systems. Other uses include the protection of fire and security alarms, industrial monitoring and control equipment.

The UTB-SP (single pair) employs a hybrid multistage clamping circuit, to help ensure the best possible protection to sensitive electronic equipment while maintaining a minimum of line interference and insertion loss.

The UTB-SPG (single pair - isolated ground) provides isolation between the shield/common return and protective ground at the point of connection.

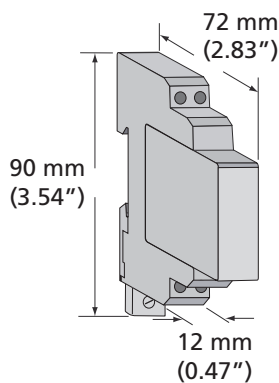

UTB Single Pair

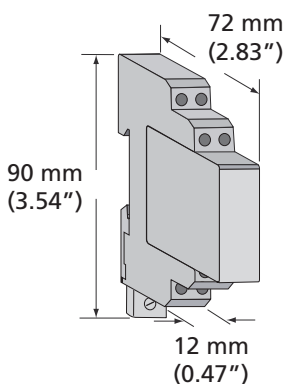
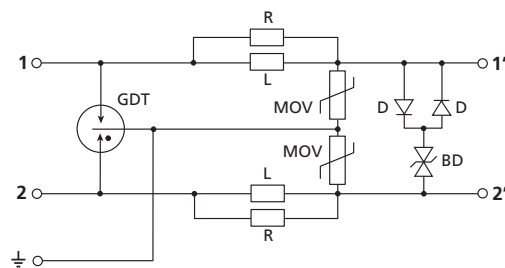

UTB Single Pair - Isolated Ground

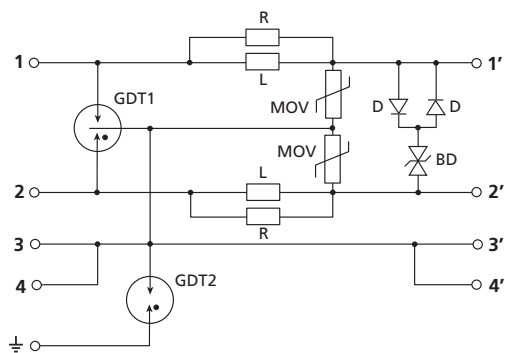

UTB Single Pair

Model	UTB55P	UTB155P	UTB30SP	UTB60SP	UTB110SP
Item Number for Europe	702861	702862	702863	702864	702866
Nominal Voltage	0 V to 3 VAC 0 V to 5 VDC	3 V to 10 VAC 5 V to 15 VDC	10 V to 21 VAC 15 V to 30 VDC	21 V to 42 VAC 30 V to 60 VDC	100 V to 120 VAC 60 V to 154 VDC
Max Cont. Operating Voltage, U_c	5 VAC 7 VDC	12 VAC 18 VDC	23 VAC 33 VDC	45 VAC 64 VDC	150 VAC 170 VDC
Max Line Current, I_L	2 A				
Frequency	0.5 MHz	1 MHz	2 MHz	3 MHz	
Loop Resistance	1.0 Ω				
Max Discharge Current, I_{max}	20 kA 8/20 μ s (L+L)-PE				
Protection Modes	Differential & Common Mode				
Technology	GDT, MOV, Silicon				
Voltage Protection Level (8/20 μ s)	L-L 10 V @ 3 kA	L-L 25 V @ 3 kA	L-L 44 V @ 3 kA	L-L 85 V @ 3 kA	L-L 220 V @ 3 kA
Dimensions H x D x W: mm (in)	90 x 72 x 12 (3.54 x 2.83 x 0.47)				
Weight: kg (lbs)	0.07 (0.15)				
Enclosure	DIN 43 880, UL [®] 94V-0 thermoplastic, IP 20 (NEMA [®] -1)				
Connection	1 mm ² to 2.5 mm ² (#18AWG to 14AWG) Grounding via terminal or DIN rail connection				
Mounting	35 mm top hat DIN rail				
Temperature	-20°C to 65°C (-4°F to 149°F)				
Approvals	CE, UL 497B				
Surge Rated to Meet	ANSI [®] /IEEE [®] C62.41.2-2002 Cat A, Cat B, Cat C				
Replacement Module	UTB55SPM	UTB155SPM	UTB30SPM	UTB60SPM	UTB110SPM
Replacement Module (Europe)	(702867)	(702868)	(702869)	(702871)	(702872)

UTB Single Pair - Isolated Ground

Model	UTB55SPG	UTB155SPG	UTB30SPG	UTB60SPG	UTB110SPG
Item Number for Europe	702873	702874	702876	702877	702878
Nominal Voltage	0 V to 3 VAC 0 V to 5 VDC	3 V to 10 VAC 5 V to 15 VDC	10 V to 21 VAC 15 V to 30 VDC	21 V to 42 VAC 30 V to 60 VDC	100 V to 120 VAC 60 V to 154 VDC
Max Cont. Operating Voltage, U_c	5 VAC 7 VDC	12 VAC 18 VDC	23 VAC 33 VDC	45 VAC 64 VDC	150 VAC 170 VDC
Max Line Current, I_L	2 A				
Frequency	0.5 MHz	1 MHz	2 MHz	3 MHz	
Loop Resistance	1.0 Ω				
Max Discharge Current, I_{max}	20 kA 8/20 μ s (L+L)-PE				
Protection Modes	Differential & Common Mode				
Technology	GDT, MOV, Silicon				
Voltage Protection Level (8/20 μ s)	L-L 10 V @ 3 kA	L-L 25 V @ 3 kA	L-L 44 V @ 3 kA	L-L 85 V @ 3 kA	L-L 220 V @ 3 kA
Dimensions H x D x W: mm (in)	90 x 72 x 12 (3.54 x 2.83 x 0.47)				
Weight: kg (lbs)	0.07 (0.15)				
Enclosure	DIN 43 880, UL 94V-0 thermoplastic, IP 20 (NEMA [®] -1)				
Connection	1 mm ² to 2.5 mm ² (#18AWG to 14AWG) Grounding via terminal or DIN rail connection				
Mounting	35 mm top hat DIN rail				
Temperature	-20°C to 65°C (-4°F to 149°F)				
Approvals	CE, UL 497B				
Surge Rated to Meet	ANSI [®] /IEEE [®] C62.41.2-2002 Cat A, Cat B, Cat C				
Replacement Module	UTB55SPGM	UTB155SPGM	UTB30SPGM	UTB60SPGM	UTB110SPGM
Replacement Module (Europe)	(702879)	(702881)	(702882)	(702883)	(702884)

Universal Transient Barrier Dual Pair



Features

- Compact design universal transient barrier – protection of low-voltage circuits and transducers
- Separate plug and base design – hot swappable feature allows ease of module replacement
- Compact, slimline two pair housing 12 mm wide
- Multi stage protection – fine over-voltage protection helps ensure lowest residual surge voltages reach sensitive equipment
- Common-mode and differential-mode protection – protects against both possible surge conditions
- Ease of grounding – through DIN mounting rail or via terminal
- Surge rating to 20 kA 8/20 μ s – ideal for exposed wiring
- “UTB-DPS” model designed for compact protection of signal and power supply in one compact housing
- Allows for protection of 50 analog signals or 100 digital signals per linear foot of DIN rail space

The UTB series is designed to provide transient protection for equipment from surges induced onto balanced pair signal lines or low-voltage AC or DC power supplies. The compact series is well suited to applications where panel space is limited, yet provides similar protection performance when compared to the UTB Modular series. They are well suited to the protection of industrial equipment such as PLCs and SCADA systems.

The UTB-DP (dual pair) employs a hybrid, multi-stage clamping circuit to help ensure the best possible protection to sensitive electronic equipment while maintaining a minimum of line interference and insertion losses.

The UTB-DPS (dual pair - single power supply, single data pair) is specifically designed for applications where compact protection is required for one signal pair and one power supply, common in powered transducer applications. The UTB-DPS combines both these protection circuits in one compact package.

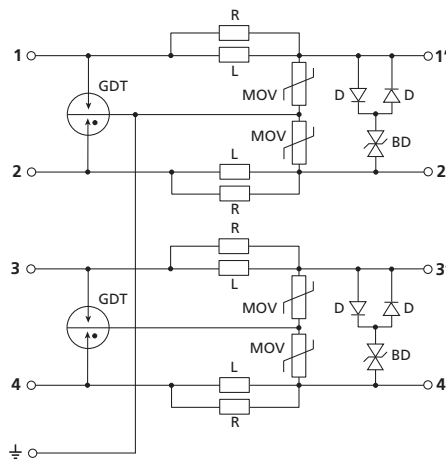
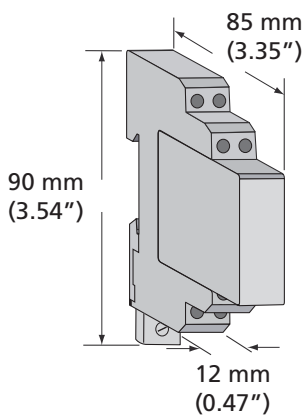

UTB Dual Pair

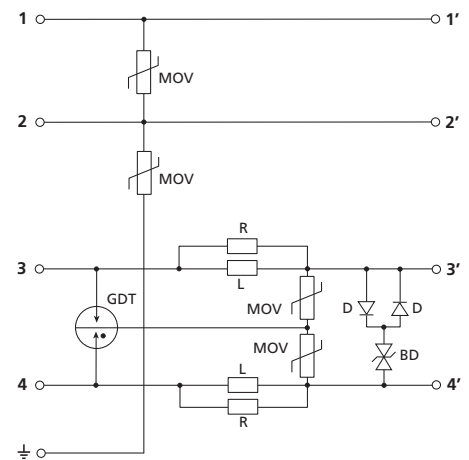

UTB Dual Pair -
Single Power Supply,
Single Data Pair



UTB Dual Pair

Model	UTB5DP	UTB15DP	UTB30DP	UTB60DP	UTB110DP	UTB30DPS
Item Number for Europe	702886	702887	702888	702889	702891	702892
Nominal Voltage	0 V to 3 VAC 0 V to 5 VDC	3 V to 10 VAC 5 V to 15 VDC	10 V to 21 VAC 15 V to 30 VDC	21 V to 42 VAC 30 V to 60 VDC	100 V to 120 VAC 60 V to 154 VDC	24 V to 48 VAC 12 V to 60 VDC
Max Cont. Operating Voltage, U _c	5 VAC 7 VDC	12 VAC 18 VDC	23 VAC 33 VDC	45 VAC 64 VDC	150 VAC 170 VDC	48 V~AC 60 VDC
Max Line Current, I _L	800 mA					5 A
Frequency	0.5 MHz	1 MHz	2 MHz	3 MHz	0-60 Hz	
Loop Resistance	0.6 Ω					0.0 Ω
Max Discharge Current, I _{max}	20 kA 8/20 μs (L+L)-PE					15 kA 8/20 μs/mode
Protection Modes	Differential & Common Mode					
Technology	GDT MOV Silicon					MOV
Voltage Protection Level (8/20μs)	L-L 10 V @ 3 kA	L-L 25 V @ 3 kA	L-L 44 V @ 3 kA	L-L 85 V @ 3 kA	L-L 220 V @ 3 kA	
Dimensions H x D x W: mm (in)	90 x 85 x 12 (3.54 x 3.35 x 0.47)					
Weight: kg (lbs)	0.09 (0.20)					
Enclosure	DIN 43 880, UL® 94V-0 thermoplastic, IP 20 (NEMA®-1)					
Connection	1 mm² to 2.5 mm² (#18AWG to 14AWG) Grounding via terminal or DIN rail connection					
Mounting	35 mm top hat DIN rail					
Temperature	-20°C to 65°C (-4°F to 149°F)					
Approvals	CE, UL 497B					
Surge Rated to Meet	ANSI®/IEEE® C62.41.2-2002 Cat A, Cat B, Cat C					
Replacement Module	UTB5DPM	UTB15DPM	UTB30DPM	UTB60DPM	UTB110DPM	UTB30DPSM
Replacement Module (Europe)	(702893)	(702894)	(702896)	(702897)	(702898)	(702899)

(1) UTB30DPS has one data/signal pair circuit equal in electrical specification rating to one pair of the UTB30DP product. The electrical specifications shown for the UTB30DPS is specific to the power supply (PS) circuit of the product.



Features

- General purpose barrier – protection of low-voltage circuits and transducers
- Separate plug and base design – hot swappable feature allows ease of module replacement
- Multi stage protection – fine over-voltage protection, helps ensure lowest residual surge voltages reach sensitive equipment
- Common-mode and differential-mode protection – protects against both possible surge conditions
- Ease of grounding – through DIN mounting rail or via terminal
- Surge rating to 20 kA 8/20 μ s – ideal for exposed wiring
- EX series for use in intrinsically safe areas

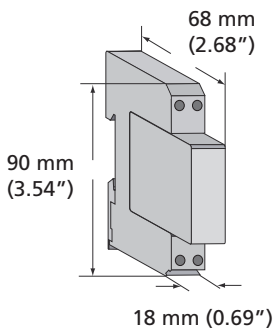

The UTB-TA and UTB-SA are specifically designed to protect telephone / modem circuits.

The UTB15EX and UTB30EX are BASEEFA approved versions for hazardous area applications (ATEX Category II 1G EEx ia IIC T4). They can be inserted without recertification into any IS loop where input <1.3W.

Telecommunications Line Protection

Model	UTBSA	UTBTA
Item Number for Europe	702860	702850
Frequency	15 MHz	
Max Discharge Current I_{max}	20 kA 8/20	500 A 8/20
Max Line Current, I_L	160 mA	
Technology	GDT, PTC	
Voltage Protection Level (8/20 μ s)	L-L: 340 V @ 3 kA	L-L: 480 V @ 3 kA
Loop Resistance	1.0 Ω	
Weight: kg (lbs)	0.1 (0.22)	
Enclosure	DIN 43 880, UL [®] 94V-0 thermoplastic, IP 20 (NEMA [®] -1)	
Connection	1 mm ² to 6 mm ² (#18AWG to #10AWG) Grounding via terminal or DIN rail connection	
Mounting	35 mm top hat DIN rail	
Temperature	-25°C to 65°C (-13°F to 149°F)	
Approvals	CE	CE, UL 497
Surge Rated to Meet	ANSI [®] /IEEE [®] C62.41.2-2002 Cat A, Cat B, Cat C	

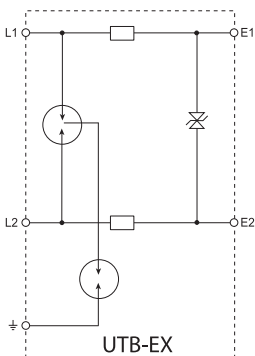
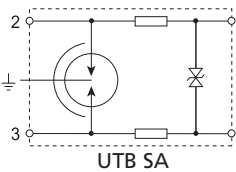
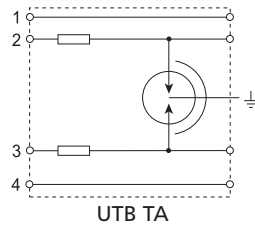

Data and Signal Line Protection

Model	UTB15EX	UTB30EX
Item Number for Europe	702811	702821
Nominal Voltage	3 V to 10 VAC, 5 V to 15 VDC	10 V to 21 VAC, 15 V to 30 VDC
Max Cont. Operating Voltage, U_c	12 VAC, 17VDC	23 VAC, 33 VDC
Frequency	1 MHz	2 MHz
Max Discharge Current I_{max}	20 kA 8/20	
Max Line Current, I_L	400 mA	80 mA
Technology	GDT, Silicon	
Voltage Protection Level (8/20 μ s)	L-L: 25 V @ 3 kA	L-L: 44 V @ 3 kA
Loop Resistance	1.0 Ω	
Weight: kg (lbs)	0.1 (0.22)	
Enclosure	DIN 43 880, UL 94V-0 thermoplastic, IP 20 (NEMA [®] -1)	
Connection	1 mm ² to 6 mm ² (#18AWG to #10AWG) Grounding via terminal or DIN rail connection	
Mounting	35 mm top hat DIN rail	
Temperature	-30°C to 65°C (-22°F to 149°F)	
Approvals	CE, UL 497B, UL 913	
Surge Rated to Meet	ANSI [®] /IEEE [®] C62.41.2-2002 Cat A, Cat B, Cat C	



ANSI is a registered trademark of the American National Standards Institute. IEEE is a registered trademark of the Institute of Electrical and Electronics Engineers, Incorporated. NEMA is a registered trademark of the National Electrical Manufacturers Association. UL is a registered certification mark of UL LLC.

Remote Transmitter Protector



Features

- 3 stage protection – fine over-voltage protection helps ensure lowest residual surge voltage reaches sensitive equipment
- Flexible installation – enclosure can be installed “dead ended”, “T” configured or in-line
- Optimized for protection of 2-wire industrial 4-20mA loops – suitable for exposed locations
- Supports line currents up to 145mA – protect 24VDC powered equipment

The RTP is designed for the protection of industrial 4-20 mA loop connected transducers. The stainless steel enclosure can be installed in-line with the field conduit, or fitted to the spare transducer connection port. Installation is simplified as the protection circuit can be removed from the enclosure to connect field wiring to the screw terminals. The RTP employs a hybrid three stage clamping circuit to help ensure the best possible protection to sensitive field equipment.

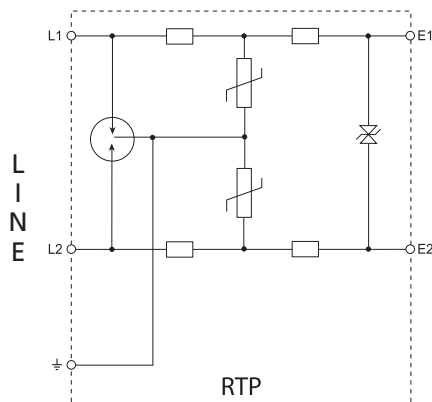
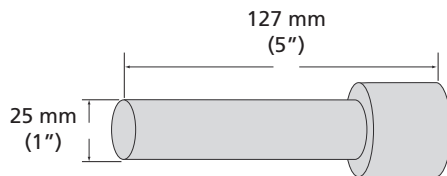

E
Q
U
I
P
M
E
N
T

Model	RTP3034
Item Number for Europe	700865
Nominal System Voltage, U_n	30 VDC & 21 VAC
Max Cont. Operating Voltage, U_c	33 VDC & 23 VAC
Max Line Current, I_L	145 mA
Frequency	3 dB @ 2 MHz (120 Ω)
Max Discharge Current, I_{max}	20 kA 8/20 μ s (L+L)-PE
Protection Modes	Differential & Common Mode
Technology	GDT MOV Silicon
Voltage Protection Level (8/20μs)	L-L 44 V @ 3 kA
Loop Resistance	14.0 Ω
Dimensions Dia. x L: mm (in)	25 x 127 (1 x 5)
Weight: kg (lbs)	0.34 (0.75)
Enclosure	304 Stainless Steel
Connection	\leq 2.5 mm ² (#14AWG)
Mounting	3/4" NPT thread (14 threads per inch)
Temperature	-40°C to 65°C (-40°F to 149°F)
Humidity	0% to 90%
Approvals	CE
Surge Rated to Meet	ANSI®/IEEE® C62.41.2-2002 Cat A, Cat B, Cat C

ANSI is a registered trademark of the American National Standards Institute.
IEEE is a registered trademark of the Institute of Electrical and Electronics Engineers, Incorporated.

Loadcell Protector



Features

- 6 wires and shield protection – works with 4 or 6 wire systems
- Suitable for compression or tension cells
- Low series impedance – loadcells do not need recalibration
- NEMA®-12 (IP-55) rated – suitable for outdoor use
- Helps protect against excitation over-voltage – helps prevent loadcell damage

The Load Cell Protector (LCP) series is designed to provide protection to load cells from lightning induced transients. Experience has shown that the strain gauge bridge is easily damaged by surge and transients. Industrial cranes are also prime targets for lightning strikes. The LCP is well suited to such

applications to help provide protection for plate cells, tension cells and load pin cells installed on cranes. The LCP is designed for 4 or 6 wire systems. Protection of the bridge, as well as the excitation voltage source is provided, using low capacitance clamping devices in order to avoid ground loop problems.

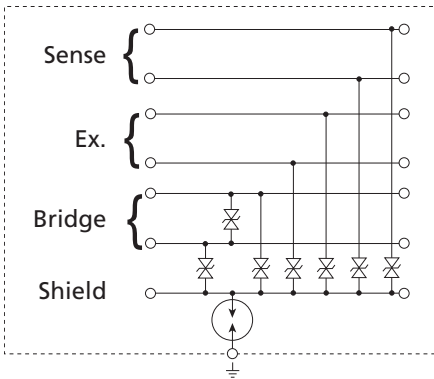

Model	LCP01A
Item Number for Europe	701610
Technology	Silicon Avalanche Diode
Max Discharge Current, I_{max}	300 A 8/20 μ s (signal to shield) 10 kA 8/20 μ s (shield to ground)
Dimensions H x D x W: mm (in)	75 x 56 x 110 (2.95 x 2.20 x 4.33)
Weight: kg (lbs)	0.25 (0.55)
Enclosure	ABS, IP55 (NEMA®-12)
Connection	Screw terminals for 4 or 6 wire loadcells
Voltage Protection Level, U_p	30 V (signal to shield) 15 V 8/20 μ s (signal to signal) 90 V (shield to ground)
Temperature	-40°C to 80°C (-40°F to 176°F)
Loop Resistance	0.3 Ω

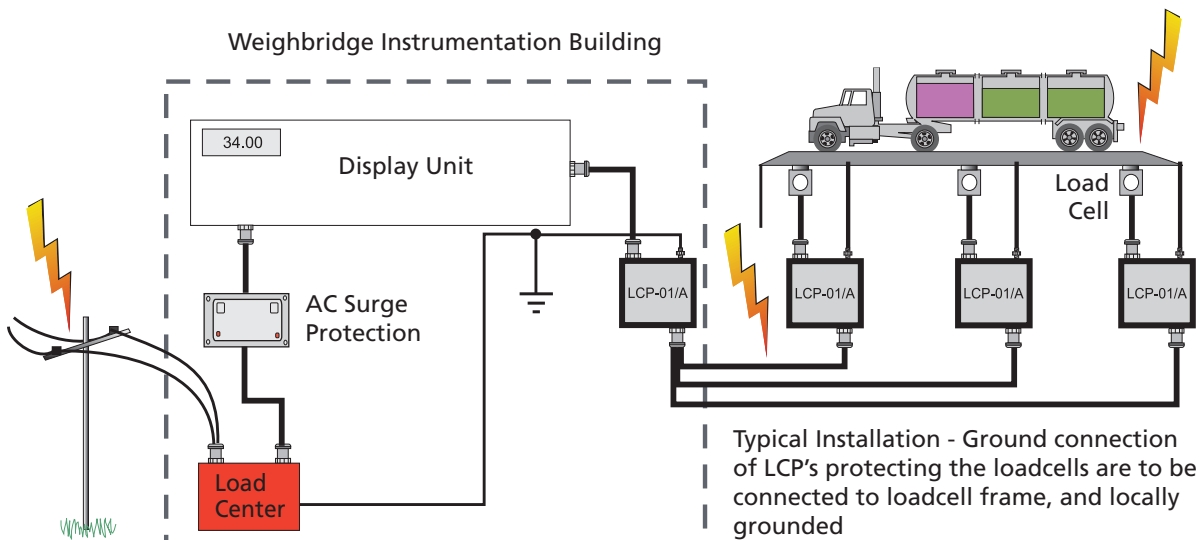

Subscriber Line / High Speed Data Line Protection

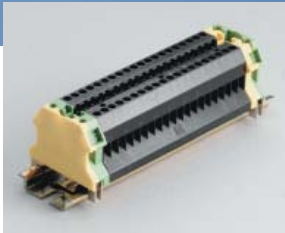

DLT (#702721) available where screw terminal connections are required (2.5 mm²)

Features

- Single and multi stage protection – primary or combination primary/secondary protectors
- Single pair and 10 pair protectors
- Simple installation into Krone-LSA® disconnect block
- L-L & L-G protection – for comprehensive protection
- HSP High Speed Protectors support 8Mbit/s digital and 12MHz analog networks

The Subscriber Line Protector (SLP) and High Speed Protector (HSP) are designed for the protection of telecommunication and data circuits that terminate on 10 pair Krone-LSA plus disconnect blocks. The DIN rail mount Data Line Termination (DLT) screw terminal block allows these protectors to be used in applications where disconnect blocks are not fitted.

The SLP1 K2 is a single pair protector, suited to protection of traditional voice circuits. The SLP10K1F is a 10 pair protector for voice and high speed data circuits.

The HSP series feature multiple protection stages providing enhanced protection. The K12, 36 and 72 are low voltage units suited to industrial/ signalling applications. The K230 is suited to protection of sensitive voice and high speed data circuits.

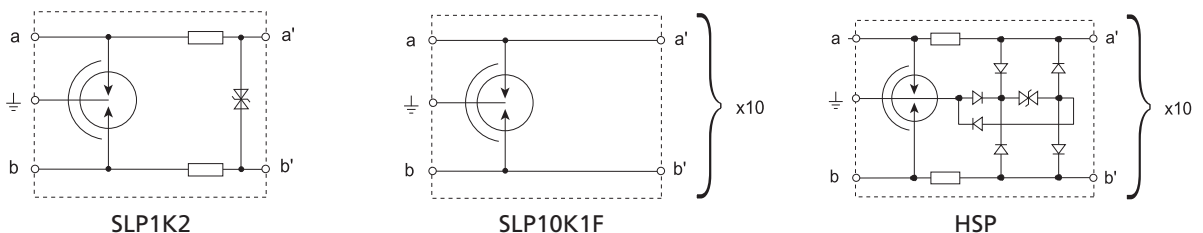

Model	HSP10K12	HSP10K36	HSP10K72	HSP10K230	SLP10K1F	SLP1K2*
Item Number for Europe	700815	700805	700850	700860	701540	
Max Cont. Operating Voltage, U _c	13 VDC	40 VDC	65 VDC	190 VDC		
Max Discharge Current, I _{max}	20 kA 8/20 μs (L+L)-E					
Technology	Multi stage				Single stage	Multi stage
Connection	Krone LSA Plus termination system					
Frequency	12 MHz; 8 Mbits					3 MHz; 2 Mbits
Dimensions H x D x W: mm (in)	35 x 21 x 125 (1.36 x 0.83 x 4.92)					35 x 21 x 10 (1.38 x 0.83 x 0.37)
Weight: kg (lbs)	.02 (.05)					.01 (.005)
Max Line Current, I _L	150 mA				1,000 mA	120 mA
Temperature	-20°C to 60°C (-4°F to 140°F)					
Impedance Balance	<55 dB				<48 dB	
Insertion Loss	<0.40 dB				<0.75 dB	
Return Loss	<20 dB				<22 dB	
Loop Resistance	16.4 Ω		6.6 Ω		0.2 Ω	20.0 Ω
Approvals	C-Tick, CE			A-Tick, C-Tick, CE, UL497		A-Tick, C-Tick, CE

*Ground bar accessory, (P/N SLP-EB), required per 10 pair Krone-LSA block when using SLP1K2 protector.

RJ11 Telephone Line Protection



Features

- RJ11 sockets – simple plug-in connection for 4 or 6 position RJ plugs
- 6.5" patch cord included – no additional cables required
- SLP RJ11 is UL 497A Listed
- L-L & L-G protection – for comprehensive protection
- Automatic over-current protection

The SLP1 RJ11 series of surge suppressors are designed to provide protection to telecommunication equipment connecting via RJ11 plugs. Designed for traditional (2 wire) telephone circuits, the product is also compatible with modems and ADSL circuits.

The SLP1 RJ11 is a UL Listed secondary protector intended for use in facilities where primary protective devices have been installed at the service entrance. The SLP1 RJ11A is a high-energy multi-stage primary protector intended for non-UL applications where higher surge ratings are required.

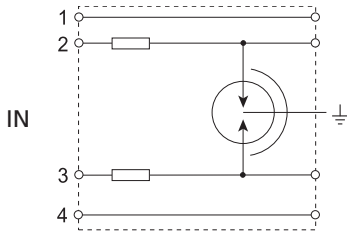

SLP1RJ11

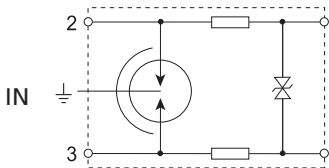

SLP1RJ11A

Model	SLP1RJ11	SLP1RJ11A
Max Cont. Operating Voltage, U_c	<280 V	
Max Discharge Current, I_{max}	500 A 8/20 μ s	20 kA 8/20 μ s
Dimensions H x D x W: mm (in)	38 x 28 x 76 (1.50 x 1.10 x 2.99)	
Weight: g (lbs)	50 (0.11)	
Connection	150 mm (6") 0.8 mm ² (#18AWG) with earth 4 mm ring lug 165 mm (6.5") patch cord included 6 position RJ, 2 pins protected	
Mounting	Adhesive backing	
Approvals	UL	A-Tick
Voltage Protection Level, U_p	110 V T-R 500 V @ 125 A (T+R)-G	
Max Line Current, I_L	160 mA	120 mA
Temperature	-40°C to 65°C (-40°F to 149°F)	



Data Equipment Protection



Features

- Premium 1500 Watt (>100 Amps 8/20µs) capability – robust protection
- Models to cover RS-232, RS-423, RS-422 and RS-485 protocols
- Designed to provide both line to signal-ground and signal-ground to protective-earth protection
- DEP RS232/25/25 protects all wires – circuit wiring/pin configuration does not need to be known
- Plug-in protection – simple to install

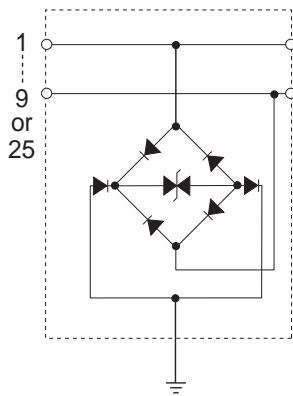

The entire line of Data Equipment Protectors has been designed to protect serial I/O interface equipment from the damaging effects of induced surges and transients. The DEP protectors are packaged in male-to-female DB9 and DB25 cases for simple installation at the serial ports of terminal equipment. For RS232/423 circuits, DEP models will allow peak working voltage of up to 15 volts, with 9 or 25 pin protection. For RS422/ 485 circuits, the DEP RS422/9/9 allows up to 9 volts working, and is packaged in a DB9 case. A flying earth lead is provided for connection to protective earth.

Model	DEPRS2322525D	DEPRS23299D	DEPRS42299D
Max Cont. Operating Voltage, U_c	15 VDC	15 VDC	9 VDC
Nominal Discharge Current, I_n	100 A 8/20 µs		
Protection Modes	All pins to ground		
Connection	DB25 Male/Female	DB9 Male/Female	

Local Area Network Protection



LANRJ45POE/C6

Features

- A range of RJ45 based surge protection products
- Compact, in-line installation
- High speed, high energy handling capability
- Low shunt capacitance to reduce signal loss.
- Adaptability to most industry applications



LANRJ45RAK
(19" rack mount kit)



Modular 19"
rack application

The Local Area Network Protector RJ45 series suits a range of applications from 10BaseT, 100BaseT, 1000BaseT to Power over Ethernet networks. The LANRJ45C6 is designed for up to 1000BaseT Category 6 Ethernet application for the protection of single circuits. It can be used individually, DIN Rail mounted

or used with the LANRJ45RAK frame for 19" rack mount applications of up to 16 units per frame. The LANRJ45POE is designed for up to Category 6 Ethernet application for the protection of single circuits in addition to the application of Power over Ethernet making this product extremely versatile.

Model	LANRJ45POE	LANRJ45C6	LANRJ45RAK
Item Number for Europe	700529	700528	700531
Clamping Voltage	60 VDC	7.5 VDC	
Frequency	100 Mbits	Cat 6	
Nominal Discharge Current, I _n	500 A 8/20 μs		
Connection	RJ45		
Mounting	Din Rail		19" rack mount
Approvals	CE		
Surge Rated to Meet	ANSI®/IEEE® C62.41.2 Cat A IEC 61643-21		



ANSI is a registered trademark of the American National Standards Institute.
IEEE is a registered trademark of the Institute of Electrical and Electronics Engineers, Incorporated.

Community Antenna and Closed Circuit Television Protection



Features

- Robust high energy protection
- Compact package for limited space requirements
- Isolated ground – does not introduce unwanted noise
- The CATVHF is designed for high frequency applications in addition to indoor or outdoor installation - suitable for digital cable.

The Closed Circuit and Community Antenna Television range of surge protectors offers a variety of protection solutions for such applications. The CATV/CCTV surge protection range is designed to protect sensitive electronic equipment from damage due to voltage transients from either the direct or indirect effects of lightning or ground potential rise.

Model	CATVMF	CATVF	CCTV12	CATVHF
Item Number for Europe	702525	702535	703000	700746
Max. Operating Voltage/Spark Over	48 VDC/60 VDC	48 VDC/60 VDC	+/- 14 VDC/30-36 V	180 V @ 10k V/μs
Nominal Discharge Current, I _{max}	5 kA 8/20 μs	5 kA 8/20 μs	10 kA 8/20 μs	5 kA 8/20 μs
Frequency	1 GHz	1 GHz	100 MHz/16 Mbits	2 GHz
Attenuation	<0.5dB 47MHz - 860MHz	<0.5dB 47MHz - 860MHz	100 MHz	-1dB @ 1GHz -2dB @ 1GHz
Impedance	50 - 75 Ω	50 - 75 Ω	50 - 75 Ω	50 - 75 Ω
Voltage Protection Level (8/20μs)	600 V @ 5 kA	600 V @ 5 kA	60 V @ 500 A	90 V @ 500 A
Dimensions H x D x W: mm (in)	70 x 17 x 17 (2.76 x 0.67 x 0.67)	78 x 17 x 17 (3.07 x 0.67 x 0.67)	90 x 28 x 22 (3.54 x 1.10 x 0.87)	96 x 31 x 63 (3.78 x 1.22 x 2.48)
Weight: g (oz)	26 (0.92)	30 (1.06)	60 (2.12)	115 (4.06)
Enclosure	Indoor	Indoor	Indoor	Outdoor
Connection	RF 9.5 mm Coax (M/F) 120 mm (4.5") ground lead	F-Type, Female, 120 mm (4.5") ground lead	BNC, Female	F-Type, Female
Mounting	In-line insertion	In-line insertion	In-line insertion	Screw mount
Temperature	-25°C to 70°C (-13°F to 158°F)			
Approvals	CE			

Coaxial Surge Protection



Features

- Simple plug-in installation
- Supplied with adjustable right angled grounded mounting block or flying lead ground.
- Low Insertion and Return Loss
- Wide Operating Frequency Spectrum
- Field serviceable, with replaceable gas arrestor

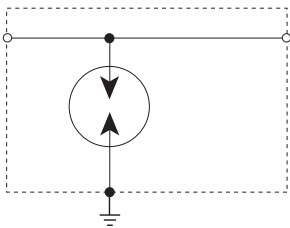

The Coaxial Surge Protector (CSP) family of surge diverters is designed to provide robust and reliable protection from transients on coaxial antenna RF feeder cables. They are comprised of a leadless gas arrestor housed in a chrome plated brass block. Careful design and precision machining has allowed the match between the characteristic impedance of the unit and the cable to be optimized. This attention to detail has resulted in a unit capable of operating at typical power and frequency levels of 900W and 3GHz respectively, while minimizing the insertion and return losses.

Model	CSP1BNC90	CSP1BNC600	CSP1NMF90	CSP1NMF600	CSP1NB90	CSP1NB600
Connection	BNC, Male / Female		N-Type, Male / Female		N-Type, Female / Female	
Spark Over Voltage @100V/μs	450V	1,100V	450V	1,100V	450V	1,100V
Spark-Over Voltage @100V/s	72V-108V	480V-720V	72V-108V	480V-720V	72V-108V	480V-720V
Model	CSP1NBM90	CSP1NBM600	CSP1F90	CSP1F600	CSP1SMA90	CSP1SMA600
Connection	N-bulkhead, Male / Female		F-Type, Male / Female		SMA, Male / Female	
Spark Over Voltage @100V/μs	450V	1,100V	450V	1,100V	450V	1,100V
Spark-Over Voltage @100V/s	72V-108V	480V-720V	72V-108V	480V-720V	72V-108V	480V-720V
Frequency	DC to 3 GHz					
Nominal Discharge Current, I_n	20kA 8/20 μs					
Dimensions H x D x W: mm (in)	25 x 57 x 25 (1 x 2.24 x 1)					
Weight: kg (lbs)	0.2 (0.44)					
Enclosure	IP20 (NEMA®-1)					
Mounting	Separate mounting bracket and ground lead connection provided					
Approvals	CE, UL® 497E					
Impulse Life	400 impulses @ 500A 10/1000μs					
Insulation Resistance	10 GΩ					
Temperature	-40°C to 90°C (-40°F to 194°F)					
Capacitance	1.5 pF					

Note: To select the appropriate protection voltage, use the following procedure:

1. Determine the transmitter power in Watts (P).
2. Determine the VSWR. If unsure, use 1.5.
3. $V_{peak} = VSWR \times 1.4 \times \sqrt{(50P)}$.
4. If $V_{peak} < 72V$, use CSP XXX 90.
If $V_{peak} > 72V$ and $< 480V$, use CSP XXX 600.
5. Taking this value of VSWR and allowing a little margin, this means that typically the 90V protector is used for Receivers and Transmitters up to 20W, while the 600V protector can be used for transmitters up to 900W.



NEMA is a registered trademark of the National Electrical Manufacturers Association.

Outdoor Weatherproof Enclosure



Features

- Polymeric base and housing is impact resistant, UV-stabilized, 94V-0 Flame Class Rating
- Integral mounting base for easy installation
- Quick-release latch with provisions for a lock
- Slots for straps (Part number CABTIESS) allowing mounting on both vertical and horizontal poles
- Grounding lug mounting option
- Two liquid-tight strain reliefs included
- 106 mm long DIN rail included
- Stainless steel mounting hardware for long life and corrosion resistance
- Enclosure meets UL® 497B rain test requirements

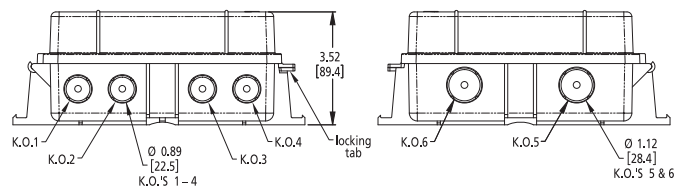
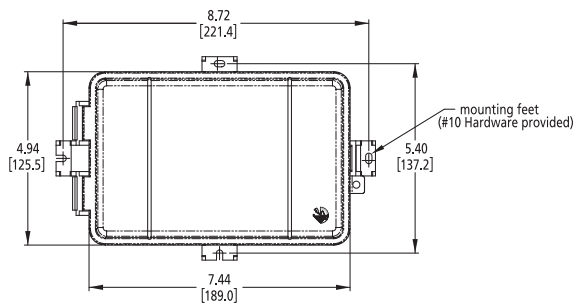

The outdoor weatherproof enclosure, part of the ERITECH® line of facility electrical protection products from ERICO, features a polymeric base and housing that is impact resistant and UV stabilized for superior durability and weatherability.

Straps can be slipped through convenient slots on the housing to allow mounting on both vertical and horizontal poles. The outdoor weatherproof enclosure

also features an integral mounting base and a quick-release latch for easy installation and operation.

For added convenience, the enclosure contains stainless steel mounting hardware, two liquid tight strain reliefs, and a 106 mm long DIN rail. A ground lug provided on the outside of the enclosure allows an attachment point to earth ground.

Model	MWE
Weight: kg (lbs)	0.54 (1.20)
Enclosure	UL® 94V-0 thermoplastic
Connection	Gray strain relief accepts cable diameter 4.6 mm (0.18") thru 11.2 mm (0.44")
Mounting	Pole mount (use CABTIESS sold separately); Wall mount (#10 hardware included)
Useable Interior Space: mm (in)	172.7 x 109.2 x 78.7 (6.8 x 4.3 x 3.1)
Internal Standoffs	Qty 5, 6-32 Tapping, 41 mm (1.61") spacing, 8 mm (0.32") height
Knockout Locations	Qty 4 on side, 2 on opposite side
Knockouts (Qty. 6)	Qty 4, 22.5 mm (0.885") Diameter hole; Qty 2, 28.5 mm (1.12") Diameter hole

Broadband Wireless Power Over Ethernet Surge Protection

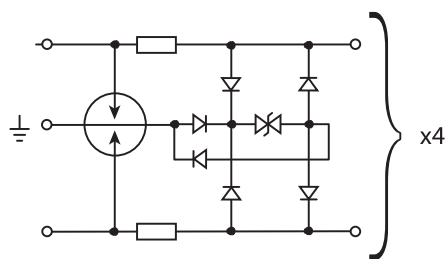

Features

- Ideal for 10/100 Base-T Cat5e protection
- All four twisted pairs protected
- Primary and secondary protection
- Weatherproof enclosure
- High-energy and high-speed capability
- Designed to minimize insertion loss and cross-talk
- Up to 25 kA 8/20 μ s protection
- Two strain reliefs, grounding lug, and #10 mounting hardware included
- Enclosure meets UL® 497B rain test requirements

The MWECSPOE offers economical and reliable protection of Power over Ethernet (PoE)-powered equipment from lightning surges and other transients. The MWECSPOE, part of the ERITECH® line of facility electrical protection products from ERICO, is enclosed in a weatherproof enclosure for protection in harsh environments. It can be easily mounted on a flat surface or pole. It is ideal for 10/100 Base-T Cat5e protection and connects to the service in a pass-through configuration.

Model	MWECSPOE
Nominal System Voltage	IEEE® 802.3 10/100 Base T PoE
Max Continuous Operating Voltage U_c	60 VDC
Frequency	10/100 Base T
Max Line Current, I_L	1 A
Max Discharge Current I_{max}	25 kA 8/20 μ s
Nominal Discharge Current	20 kA 8/20 μ s
Protection Modes	Differential & Common Mode
Technology	Multi stage
Voltage Protection Level (8/20 μs)	<50V L-L @ 3kA
Weight: kg (lbs)	0.60 (1.32)
Enclosure	UL 94V-0 thermoplastic
Connection	Screw terminals (28 AWG to 14 AWG) Gray strain relief accepts cable diameter 4.6 mm (0.18") thru 11.2 mm (0.44")
Mounting	Pole mount (use CABTIESS sold separately); Wall mount (#10 hardware included)
Temperature	-40°C to 80°C (-40°F to 176°F)
Approvals	UL 497B
Surge Rated to Meet	ANSI®/IEEE® C62.41.2 Cat A, Cat B, Cat C
Breakdown Voltage (L-L)	60-90V



ANSI is a registered trademark of the American National Standards Institute.
IEEE is a registered trademark of the Institute of Electrical and Electronics Engineers, Incorporated.
UL is a registered certification mark of UL LLC.

Outdoor Surveillance System Surge Protector



Features

- Surge protection for coaxial-fed video surveillance cameras with PTZ capability
- Weatherproof enclosure
- Designed to protect power, video and data lines
- Up to 25 kA 8/20 μ s protection
- Low clamping voltage
- Four strain reliefs, grounding lug, and #10 mounting hardware included
- Enclosure meets UL[®] 497B rain test requirements

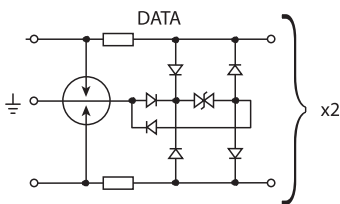
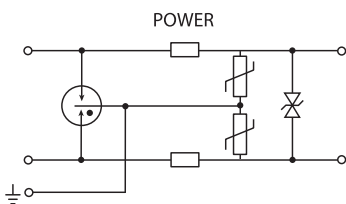
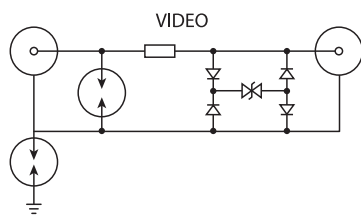

The MWESS is designed to provide economical and reliable surge protection from lightning and other transients for coax-fed video surveillance cameras with PTZ capability. The MWESS, part of the ERITECH[®] line of facility electrical protection products from ERICO, is enclosed in a weatherproof enclosure for protection in harsh environments. It can be easily mounted on a flat surface or pole. The MWESS connects to the service in a pass-through configuration. The MWESS includes four strain reliefs, a grounding lug, and #10 mounting hardware.

Model	MWESS
Nominal System Voltage	24VAC/12VDC (Power), <5VDC (Data), <5Vpp (video)
Frequency	100 MHz/16 Mbits
Max Line Current, I _L	3 A
Max Discharge Current I _{max}	25 kA 8/20 μ s (DATA/POWER)
Nominal Discharge Current	20 kA 8/20 μ s
Protection Modes	Differential & Common Mode
Technology	Multi stage
Voltage Protection Level (8/20 μ s)	Power/Data : <50V L-L @ 3kA; Video: 60 V @ 500 A
Weight: kg (lbs)	0.60 (1.32)
Enclosure	UL 94V-0 thermoplastic
Connection	BNC, Female, Screw terminals (28 AWG to 14 AWG); Gray strain relief accepts cable diameter 4.6 mm (0.18") thru 11.2 mm (0.44"); Black strain relief accepts cable diameter 5.8 mm (0.26") thru 13.9 mm (0.546")
Mounting	Pole mount (use CABTIESS sold separately); Wall mount (#10 hardware included)
Temperature	-40°C to 80°C (-40°F to 176°F)
Approvals	UL 497B
Surge Rated to Meet	ANSI [®] /IEEE [®] C62.41.2-2002 Cat A, Cat B, Cat C
Max Continuous Operating Voltage U _c	28 VAC / 40 VDC (Power) 9 VDC (Data), 33 VDC (Video)
Breakdown Voltage (L-L)	
Video 100V/s	25 - 50 V
Data 100V/s	5 - 10 V
Power 100V/s	30 - 50 V
Breakdown Voltage (L-G)	95 - 110 V

ANSI is a registered trademark of the American National Standards Institute.
 IEEE is a registered trademark of the Institute of Electrical and Electronics Engineers, Incorporated.
 UL is a registered certification mark of UL LLC.

Outdoor Local Area Network Protector

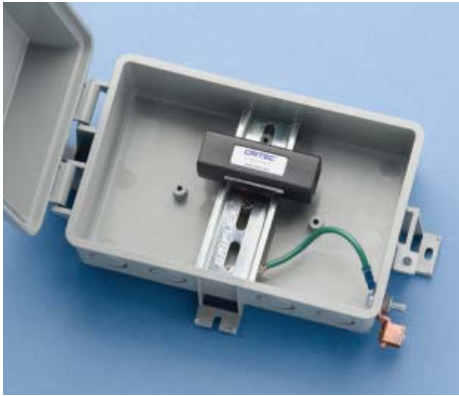

Features

- Designed for the protection of up to two PoE-powered devices, such as surveillance cameras, subscriber units, traffic lights, etc.
- Weatherproof enclosure
- Compact, in-line installation
- High-speed capability
- Low-shunt capacitance to reduce signal loss
- Adaptability to most industry applications
- Enclosure meets UL® 497B rain test requirements

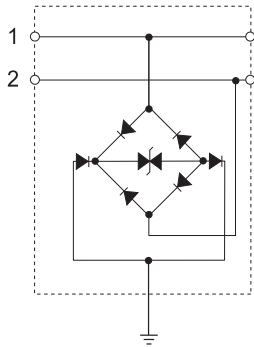

The MWERJ451 and MWERJ452 series of broadband wireless surge protection products are designed to provide economical and reliable protection from lightning and other transients. Part of the ERITECH® line of facility electrical protection products from ERICO, the MWERJ451 and MWERJ452 are enclosed in a weatherproof enclosure for protection in harsh environments. They can be easily mounted on a flat surface or pole. The products connect to the service in a pass-through configuration.

Model	MWERJ451	MWERJ452
Nominal System Voltage	IEEE® 802.3 10/100 Base T PoE	
Max Continuous Operating Voltage U _c	66 VDC	
Frequency	10/100 Base T	
Nominal Discharge Current	500 A 8/20 μs	
Protection Modes	All 8 pins	
Weight: lbs (kg)	1.43 (0.65)	1.54 (0.70)
Enclosure	UL® 94V-0 thermoplastic	
Connection	RJ45	
Mounting	Pole mount (use CABTIESS sold separately); Wall mount (#10 hardware included)	
Temperature	-40°C to 80°C (-40°F to 176°F)	
Surge Rated to Meet	ANSI®/IEEE® C62.41.2 Cat A IEC® 61643-21	
Protectors	1	2



ANSI is a registered trademark of the American National Standards Institute.
IEC is a registered service mark of Independent Electrical Contractors, Inc.
IEEE is a registered trademark of the Institute of Electrical and Electronics Engineers, Incorporated.
UL is a registered certification mark of UL LLC.

Potential Equalization Clamp



Features

- High peak current capability – long service life
- Weatherproof enclosure – suitable for direct burial
- The PEC100 is ATEX approved – suitable for use in potentially explosive atmospheres
- The PEC150 offers a higher surge rating of 50kA 10/350µs specially designed for Class N (Normal Duty) to EN50164-3.

The PEC is an equipotential bonding device that is designed to minimize damage in applications where separated ground systems are required. The PEC100 model is ATEX approved making the device suitable for use in explosion hazard areas

such as the protection of pipeline insulated joints. The PEC150 model is a higher surge rated product for more exposed locations subject to partial direct lightning strike.

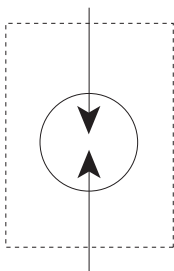

Model	PEC100	PEC150
Item Number for Europe	702900	702901
Spark-Over Voltage @100V/s	350 V*	800 V*
Max Discharge Current, I _{max}	100 kA 8/20 µs	150 kA 8/20 µs
Technology	Gas Discharge Tube (Auto reset)	
Insulation Resistance	>1 GΩ	
Capacitance	<15.0 pF	
Voltage Protection Level, U _p	800 V @ 1 kV/µs	1.5 kV @ 1 kV/µs
Impulse Current, I _{imp}	25 kA 10/350 µs	50 kA 10/350 µs
Dimensions L x Ø: mm (in)	138 x 25 (5.43 x 0.98)	105 x 42 (4.13 x 1.65)
Weight: kg (lbs)	0.5 (1.10)	0.7 (1.54)
Enclosure	Suitable for outdoor or direct burial	
Connection	450 mm of 16 mm ² (17" of #5AWG) conductor	
Temperature	-30°C to 70°C (-22°F to 158°F)	
Approvals	CE, ATEX, BASEEFA Approved, IEC® 60079-0-15	CE, EN50164-3:2004 N (normal duty)

*Spark-over voltage has a tolerance of +/- 20%

DINLINE Decoupling Inductor/ DINLINE Alarm Relay & Surge Counter



Features

- 35 mm² tunnel terminals – accepts large cable size
- 63A model features top and bottom terminals – flexible installation
- The DINLINE Alarm Relay (DAR) is used with TDF products where alarm contacts are required for remote signaling
- The TDS-SC Surge Counter provides a non-resettable record of the number of surges diverted
- Use for decoupling of spark gaps and MOVs – allows correct coordination of different SPD technologies

Decoupling inductors are installed between spark gap and MOV protection devices to help ensure correct coordination. As the decoupling inductors are installed in series with the load, two units are available, a compact unit for circuits up to 35A and a larger unit for 63A circuits.

The DAR (DINLINE Alarm Relay) can be connected to TDF units to provide potential free change-over alarm

contacts. The TDS SC (Surge Counter) unit is designed to provide visual indication of the number of surges registered. It uses a current transformer through which the ground conductor connecting to one, or all, of the surge protection modules is fed. Current diverted by the operation of the surge module, which exceeds a 300A trip threshold, will be registered on the counter.

Model	TDSSC
Status	Maximum count 9999 Non-resettable
Dimensions H x D x W: mm (in)	90 x 68 x 36 (3.54 x 2.68 x 1.42)
Module Width	2 M
Weight: kg (lbs)	0.4 (0.88)
Enclosure	DIN 43 880, UL 94V-0 thermoplastic, IP 20 (NEMA [®] -1)
Connection	1 mm ² to 6 mm ² (#18 AWG to #10)
Mounting	35 mm top hat DIN rail
Temperature	-35°C to 55°C (-31°F to 131°F)
Approvals	AS3260, C-Tick, CE, CSA 22.2



NEMA is a registered trademark of the National Electrical Manufacturers Association.



Features

- 1mA nominal (0.8 - 1.2mA) test current
- 1kV/s nominal (0.8-1.2kV/s) test voltage slwe rate
- 3 digit LCD display
- Test leads supplied with probes and removable crocodile clips

The MGA-TESTER is designed for rapid testing of the integrity of both metal oxide varistors (MOVs) and gas arresters (gas discharge tubes). This portable microprocessor unit is designed to test surge components with ratings up to 900V.

Because standard MOVs and gas arresters do not provide the user with a visual indication of the integrity of the protection capacity an external means of testing is required. It is impossible to predict when these failures will occur without some form of testing.

As MOVs approach the end of their life cycle they exhibit a change in tolerance levels. The MOV & Gas Arrester Test Unit is specifically designed to identify this situation and allows the operator to effect remedial replacement to the devices which are nearing the end of their life cycle. The MOV and Gas Arrester Test Unit will also indicate if a MOV is non functional.

Model	MGATESTER
Dimensions H x D x W: mm (in)	195 x 43 x 99 (7.67 x 1.70 x 3.90)
Weight: kg (lbs)	0.68 (1.50)

ERICO®



www.erico.com



AUSTRALIA
Phone 1-800-263-508
Fax 1-800-423-091

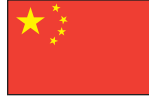

CHINA
Phone +86-21-3430-4878
Fax +86-21-5831-8177



HUNGARY
Phone 06-800-16538
Fax +39-0244-386-107



NORWAY
Phone 800-100-73
Fax 800-100-66



SWITZERLAND
Phone 0800-55-86-97
Fax 0800-55-96-15



BELGIUM
Phone 0800-757-48
Fax 0800-757-60



DENMARK
Phone 808-89-372
Fax 808-89-373



INDONESIA
Phone +62-21-575-0941
Fax +62-21-575-0942



POLAND
Phone +48-71-349-04-60
Fax +48-71-349-04-61



THAILAND
Phone +66-2-267-5776
Fax +66-2-636-6988



BRAZIL
Phone +55-11-3623-4333
Fax +55-11-3621-4066



FRANCE
Phone 0-800-901-793
Fax 0-800-902-024



ITALY
Phone 800-870-938
Fax 800-873-935



SINGAPORE
Phone +65-6-268-3433
Fax +65-6-268-1389



UNITED ARAB EMIRATES
Phone +971-4-881-7250
Fax +971-4-881-7270



CANADA
Phone +1-800-677-9089
Fax +1-800-677-8131



GERMANY
Phone 0-800-189-0272
Fax 0-800-189-0274



MEXICO
Phone +52-55-5260-5991
Fax +52-55-5260-3310



SPAIN
Phone 900-993-154
Fax 900-807-333



UNITED KINGDOM
Phone 0808-2344-670
Fax 0808-2344-676



CHILE
Phone +56-2-370-2908
Fax +56-2-369-5657



HONG KONG
Phone +852-2764-8808
Fax +852-2764-4486



NETHERLANDS
Phone 0800-0200-135
Fax 0800-0200-136



SWEDEN
Phone 020-790-908
Fax 020-798-964



UNITED STATES
Phone 1-800-753-9221
Fax +1-440-248-0723

ANSI is a registered trademark of the American National Standards Institute.
IEEE is a registered trademark of the Institute of Electrical and Electronics Engineers, Inc.
NEMA is a registered servicemark of the National Electrical Manufacturers Association.
UL is a registered certification mark of UL LLC.

WARNING

ERICO products shall be installed and used only as indicated in ERICO's product instruction sheets and training materials. Instruction sheets are available at www.erico.com and from your ERICO customer service representative. Improper installation, misuse, misapplication or other failure to completely follow ERICO's instructions and warnings may cause product malfunction, property damage, serious bodily injury and death.

WARRANTY

ERICO products are warranted to be free from defects in material and workmanship at the time of shipment. NO OTHER WARRANTY, WHETHER EXPRESS OR IMPLIED (INCLUDING ANY WARRANTY OF MERCHANTABILITY OR FITNESS FOR A PARTICULAR PURPOSE), SHALL EXIST IN CONNECTION WITH THE SALE OR USE OF ANY ERICO PRODUCTS. Claims for errors, shortages, defects or nonconformities ascertainable upon inspection must be made in writing within 5 days after Buyer's receipt of products. All other claims must be made in writing to ERICO within 6 months from the date of shipment or transport. Products claimed to be nonconforming or defective must, upon ERICO's prior written approval in accordance with its standard terms and procedures governing returns, promptly be returned to ERICO for inspection. Claims not made as provided above and within the applicable time period will be barred. ERICO shall in no event be responsible if the products have not been stored or used in accordance with its specifications and recommended procedures. ERICO will, at its option, either repair or replace nonconforming or defective products for which it is responsible or return the purchase price to the Buyer. THE FOREGOING STATES BUYER'S EXCLUSIVE REMEDY FOR ANY BREACH OF ERICO WARRANTY AND FOR ANY CLAIM, WHETHER SOUNDING IN CONTRACT, TORT OR NEGLIGENCE, FOR LOSS OR INJURY CAUSED BY THE SALE OR USE OF ANY PRODUCT.

LIMITATION OF LIABILITY

ERICO excludes all liability except such liability that is directly attributable to the willful or gross negligence of ERICO's employees. Should ERICO be held liable its liability shall in no event exceed the total purchase price under the contract. ERICO SHALL IN NO EVENT BE RESPONSIBLE FOR ANY LOSS OF BUSINESS OR PROFITS, DOWNTIME OR DELAY, LABOR, REPAIR OR MATERIAL COSTS OR ANY SIMILAR OR DISSIMILAR CONSEQUENTIAL LOSS OR DAMAGE INCURRED BY BUYER.

Copyright ©2003, 2006, 2011, 2012, 2013 ERICO International Corporation. All rights reserved.
CADDY, CADWELD, CRITEC, ERICO, ERIFLEX, ERITECH, and LENTON are registered trademarks of ERICO International Corporation.

E987C-WWEN E3752CT13WWEN WB1113