

AW LED SERIES AREA WARNING LIGHT



HUBBELL
Industrial Lighting

CAT.#		APPROVALS
JOB	TYPE	

SPECIFICATIONS

Applications -

- For use as obstruction indication for buildings and towers.

Specifications -

- Uses 95% less energy than incandescent, only 6.5 total watts per unit
- Available as a single, dual or retro-fit unit
- Available in 120 - 277VAC
- Lasts years longer than an incandescent
- Weather/corrosion resistant lamp assembly and housing
- Red polycarbonate lens
- Self-contained wiring compartment eliminates additional boxes
- Threaded 1" side and bottom hubs for single unit
- Threaded 1" bottom hub for dual unit
- Both units supplied with adapter for 3/4" mount
- Resistant to shock and vibration
- IP66 / NEMA 4X

Listings -

- UL listed

Certifications/Compliance -

- FAA AC NO: 150/5345-43G (Red Obstruction Lighting)



ORDERING INFORMATION

ORDERING EXAMPLE: AWSP3120



SERIES

AWSP3120	Single AW LED area warning light
AWDP3120	Twin AW LED area warning light
AWRETRO120	Retro-fit AW LED area warning light

SPARE PARTS FOR INCANDESCENT SERIES (ORDER SEPARATELY)

7AP53	Clear Lens
7AP53B	Blue Lens
7AP53G	Green Lens
7AP53R	Red Lens
7AP53Y	Amber Lens
7AP3A	Internal Relay to change lamps on twin unit

DIMENSIONS

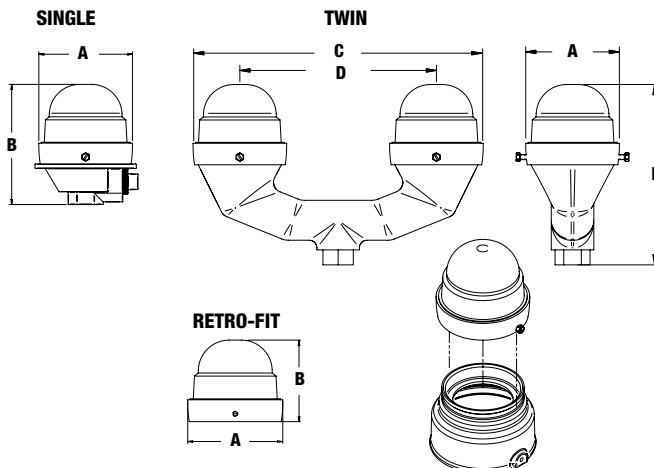

	A	B	C	D
TWIN	4.62"	8.90"	14.40"	9.80"
	117.35mm	226.06mm	365.76mm	248.92mm
SINGLE	4.62"	5.93"	N/A	N/A
	117.35mm	150.62mm	N/A	N/A
RETRO-FIT	4.62"	4.00"	N/A	N/A
	117.35mm	101.60mm	N/A	N/A

Due to our continued efforts to improve our products, specifications are subject to change without notice. Copyright © Hubbell Lighting. All Rights Reserved.

For more information visit our web site: <http://www.hubbellindustrial.com/>
Phone: 1-864-678-1000



HUBBELL
Lighting