

NAMPOWERTM

RESOURCE GUIDE

Information on Tool Selection,
Grit Selection, Suggested RPM's and More

GENERAL APPLICATION AND SELECTION OF

NAMPOWER™

DISC BRUSHES



Brush Research Manufacturing is proud to offer the highest quality professional grade tools for deburring, edge radiusing and surface finishing applications on the market today: Nampower™ Disc Brushes. Composed of flexible abrasive nylon filaments bonded to a fiber reinforced thermoplastic base, these abrasive disc brushes contain a unique combination of both ceramic and silicon carbide abrasive that produce maximum burr removal rates and provides an optimum surface finish at the same time. The brushes are available in 2 different styles: Dot Style for general purpose deburring and surface finish applications and the Turbine Style brush for medium and heavy deburring applications.

These high-performance tools create reliable, consistent and cost effective results. Nampower™ Disc Brushes are easily integrated into today's automated machinery, CNC machining centers, transfer lines and robotic cells.

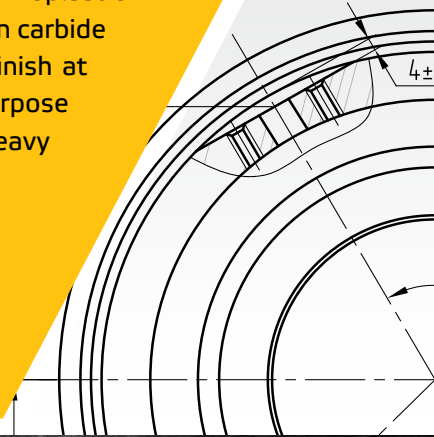

BRUSH SELECTION

DOT STYLE



Used for general purpose edge deburring and surface finishing applications. The Dot style is an economical choice for light deburring applications. Dot style brushes provide greater flexibility and allow entry into small holes and spaces with ease.

TURBINE STYLE



Ideal for medium and heavy deburring applications. The Turbine style brush has a high density fill that is ideal for short cycle times and long tool life.

TRIM LENGTH SELECTION

The Nampower disc brush is available in 18mm and 38mm trim lengths. Trim length selection is about flexibility versus aggressiveness. Longer trim lengths are less aggressive and more flexible while shorter trim lengths are less flexible and more aggressive. Burr size, part shape and conformity, radius requirements and final finish requirements are all factors affecting trim length selection.

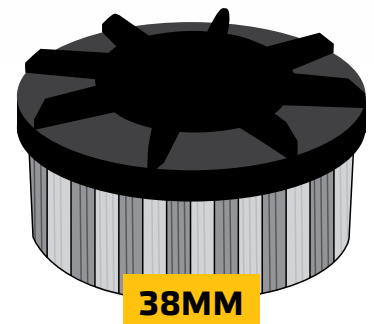
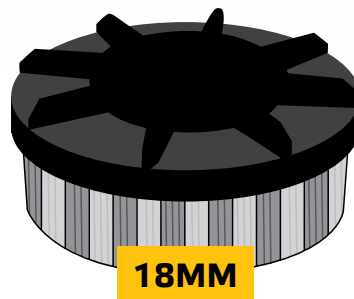
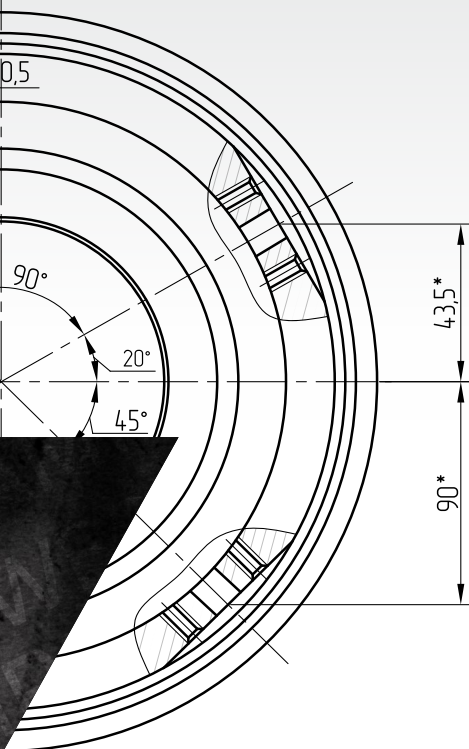

GRIT SELECTION

GRIT SELECTION

STARTING RA

80	50-60
120	40-50
180	30-40
320	20-30

Grit selection is highly dependent on the starting surface finish and the amount of material refinement required. The general rule of thumb is to choose the coarsest grit possible that will still yield the required surface finish. A fine grit tool used on a coarse starting finish will have less effect on the overall finish improvement as a coarse grit tool followed by a finer grit tool. Coarse grits are recommended for use on heavier burrs or where a fine surface finish is not required.

SELECTING BRUSH DIAMETER, PART COVERAGE

Part Coverage: The brush should ideally be three inches larger than the work piece. If a smaller brush is required due to fixture restrictions, the centerline of the brush tool should be aligned with the targeted edge with a minimum of 1-1/2" of overlap.

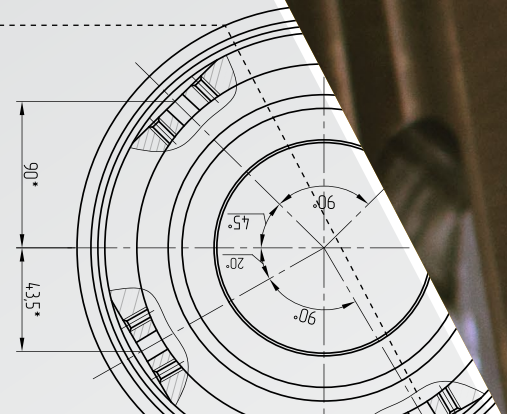
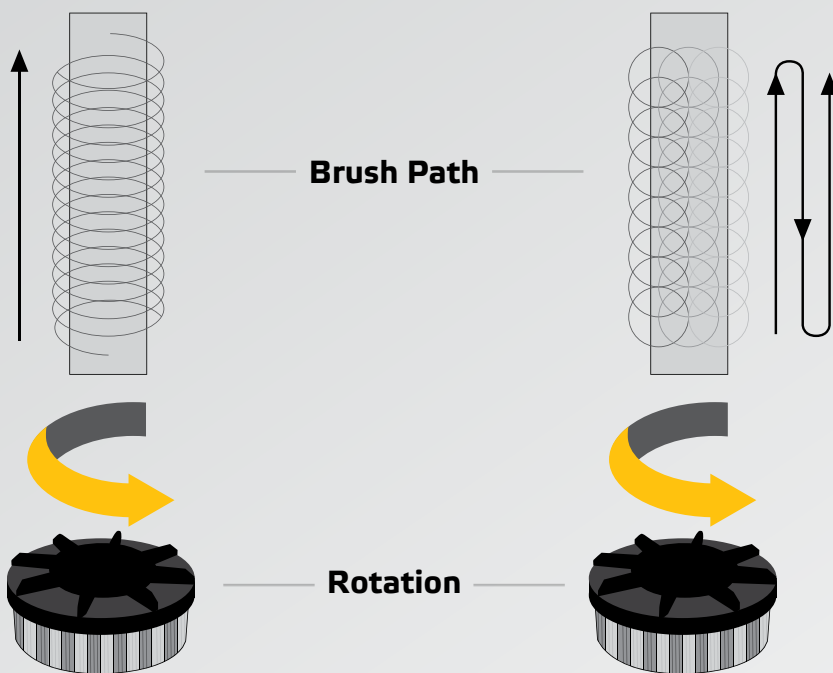

TOOL PATH ROTATIONAL DIRECTION

Tool Path: The brush should be rotating at full speed and start and finish its path completely off the part.

Rotational Direction: The brush should be rotated in the direction opposite of the cutting tool that created the burr on its initial pass.

EASILY INTEGRATED

INTO TODAY'S AUTOMATED MACHINERY,
CNC MACHINING CENTERS, TRANSFER LINES
AND ROBOTIC CELLS

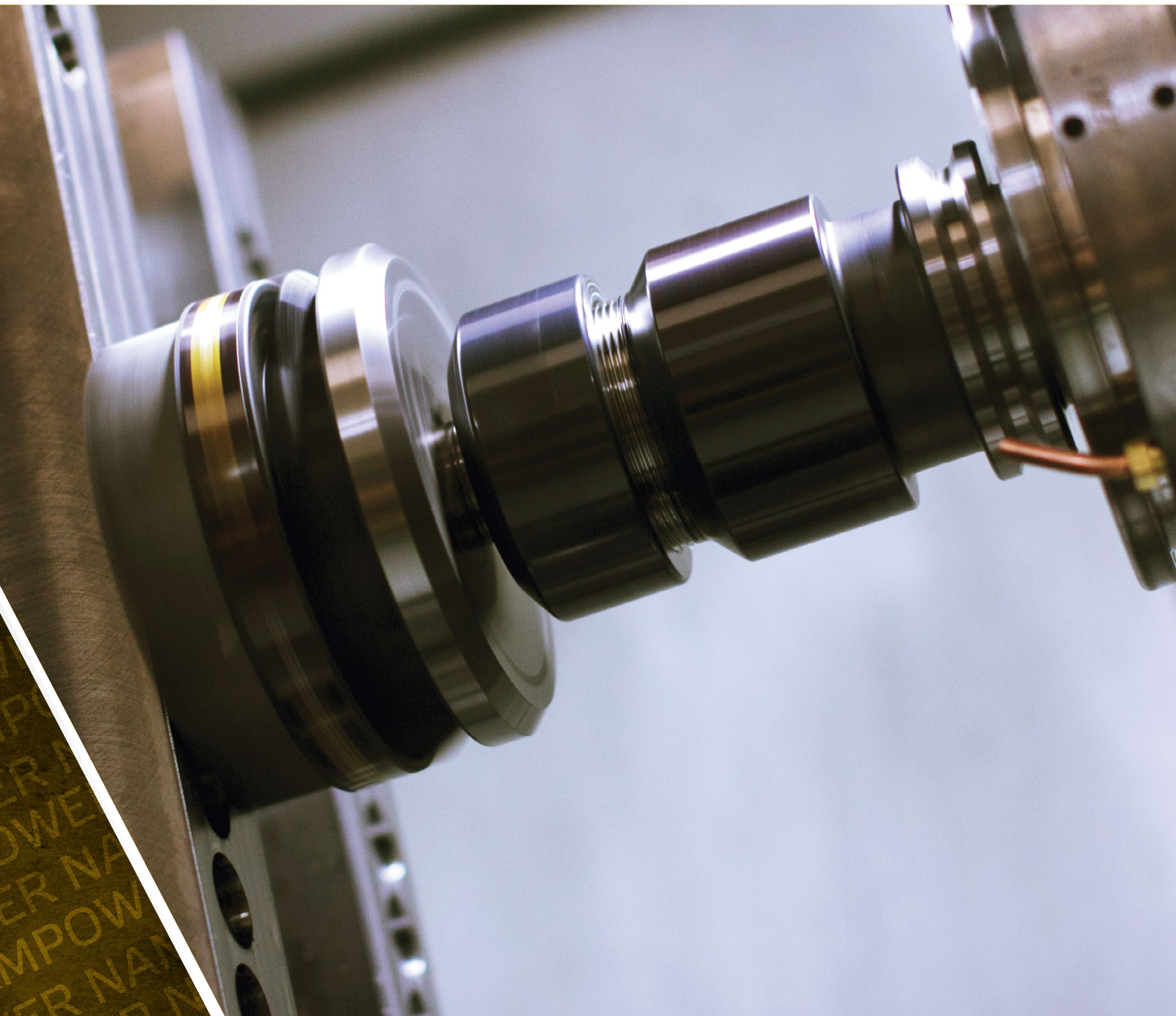

SUGGESTED OPERATING PARAMETERS

SPEED

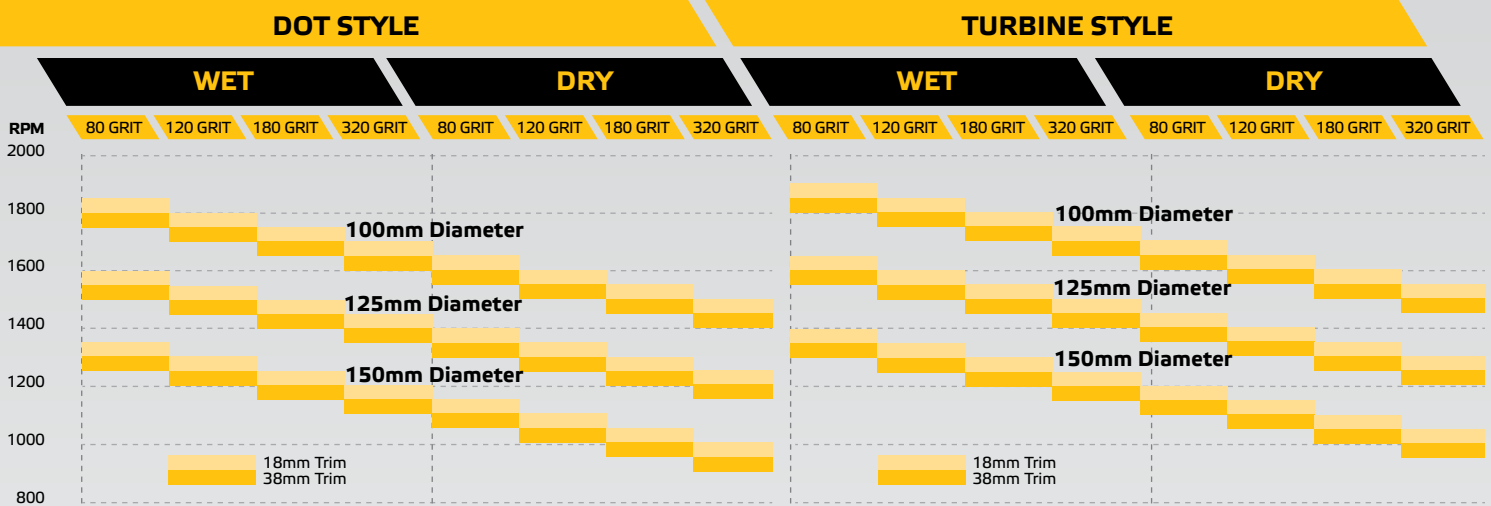

Brushes should be operated at surface speeds lower than the maximum MSFS listed to prevent overheating and smearing of the nylon onto the work surface. The maximum RPM marked on the brush is not the optimum working speed. It is recommended to stay under 2,500 SFPM in dry applications and 3,500 SFPM in wet applications. A 150mm diameter brush running at 1400 RPM is much more effective than one running at 2800 RPM. Excessive speed, especially with longer trim length, causes the filament to flair and bounces off the work piece. Lower surface speed is also important when brush conformability is important. Typically, higher spindle speeds improve the aggression and lower speeds enhance the conformability.

CUT DEPTH

BRUSH STYLE

CUT DEPTH

Dot Style	.015 – .150
Turbine Style	.007 – .093

Cut depth should be set up to 10% penetration of the available trim length on the smaller diameter filaments and up to 5% penetration on larger diameter filaments. Spindle speed is usually decreased with increased depth of interference, so the filaments can conform smoothly to part contours. This combination ensures that filaments do not hit the part and bounce off its surfaces, but are deburring as the filaments are wiping across its surfaces and edges like a file. This brushing action also contributes to longer brush life.

FEED RATE

MATERIAL

FEED RATE

Non-Ferrous	80 in./min.
Cast Iron	60 in./min.
Mild Steel and Ductile Iron	50 in./min.
Stainless and Alloy Steels	30 in./min.
Titanium and High Nickel Alloys	30 in./min.

Feed rate is affected by many factors including burr size, work piece material, surface contours and finish requirements. Contoured surfaces are processed at slower speeds and greater depth of interference than flat surfaces. Starting feed rates between 30fpm and 80fpm are recommended but the final feed rate is application specific and must be developed through deburring trial.

WEAR COMPENSATION

It is possible to automate wear compensation on dedicated equipment, by using electronic controls to monitor the load on drive motors to adjust the position of the brushing tool to maintain a relatively consistent amount of pressure. Standard CNC machines which do not have the possibility of automated load adjustments need to try other methods like automatic indexing, probe control or manual setting.



APPLICATION GUIDELINES

For More Aggression

- Reduce trim length
- Use larger diameter brush
- Increase grit size
- Use heavy density bristle brush
- Increase spindle RPM
- Increase depth

For Less Aggression

- Increase trim length
- Use smaller diameter brush
- Use finer grit size
- Use medium less density bristle brush
- Reduce pressure

For Contouring

- Increase trim length
- Use fine grit bristle
- Use light density bristle brushes
- Increase pressure

For Fine Finishing

- Use brush with a coolant
- Use long bristle brush
- Increase spindle RPM

For Coarse Finishing

- Use brush without coolant
- Increase grit size
- Use smaller diameter brush
- Reduce spindle RPM

For Smear Free

- Use brush with a coolant work piece
- Use smaller diameter brush
- Reduce spindle RPM
- Decrease pressure

GENERAL APPLICATION AND SELECTION OF

NAMPOWER™

COMPOSITE HUB WHEEL BRUSHES



Brush Research's NamPower™ composite hub wheel brushes are abrasive nylon brushing tools for machine-based and offhand deburring, surface finishing, and edge radiusing. These safe, dependable radial wheel brushes feature indestructible cores with higher filament density and balanced construction. An alternative to wire wheels and non-woven abrasive brushes, NamPower composite hub wheel brushes are used in the production of turbine blades, steel gears, machine parts, extrusion cut-offs and shaft finishing and they produce an edge radius on cutting tool inserts. When selecting composite hub wheel brushes, as with all industrial brushes, it is important to consider the proper diameter, face width, and trim length. The brush's face width must be wide enough to deburr a wide edge but the tool's face should be narrow enough to access part recesses that also may finishing. The abrasive grit selected will affect cutting and finish. Grit selection influences flexibility as well. The coarser the abrasive grit (lower number), the larger the filament diameter is.



BRUSH DIAMETER SELECTION

Nampower Composite Hub Wheels comes standard in 6 inch and 8 inch diameters. Larger diameter brushes are less aggressive and more flexible while shorter smaller diameter brushes are less flexible and more aggressive. Burr size, part shape and conformity, radius requirements, final finish requirements and the machinery the brush is used on are all factors affecting brush diameter selection.

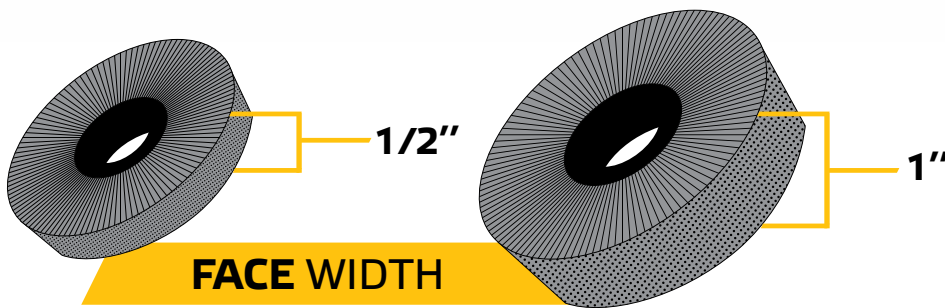
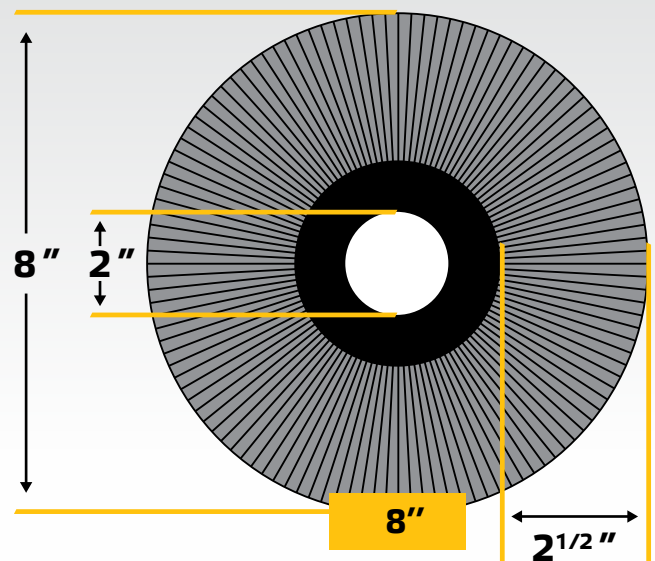
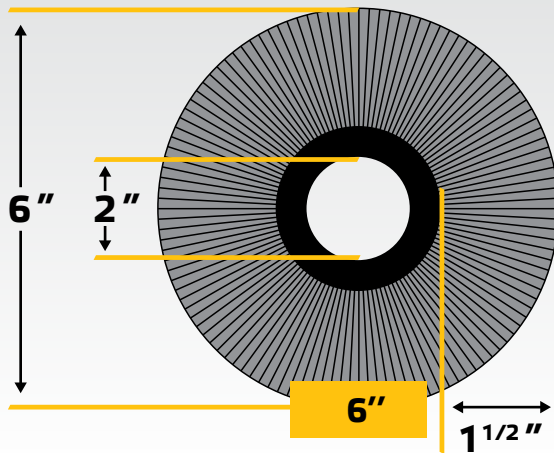

FACE WIDTH

GRIT SELECTION

GRIT SELECTION

STARTING RA

80	50-60
120	40-50
180	30-40
320	20-30

Grit selection is highly dependent on the starting surface finish and the amount of material refinement required. Choose the coarsest grit possible that will still yield the required surface finish. A fine grit tool used on a coarse starting finish will have less effect on the overall finish improvement as a coarse grit tool followed by a finer grit tool. Coarse grits are recommended for use on heavier burrs or where a fine surface finish is not required.



ARBOR ADAPTERS

PART ID	PART DESCRIPTION
CWA2-12	COMPOSITE WHEEL ADAPTER 2" - 1/2"
CWA2-58	COMPOSITE WHEEL ADAPTER 2" - 5/8"
CWA2-34	COMPOSITE WHEEL ADAPTER 2" - 3/4"
CWA2-78	COMPOSITE WHEEL ADAPTER 2" - 7/8"
CWA2-1	COMPOSITE WHEEL ADAPTER 2" - 1"
CWA2-114	COMPOSITE WHEEL ADAPTER 2" - 1-1/4"
CWA2-112	COMPOSITE WHEEL ADAPTER 2" - 1-1/2"



Brush Research produces machined arbor adapters in a variety of sizes. These adapters are designed to offer increased brush support, less brush vibration and longer brush life.

SUGGESTED OPERATING PARAMETERS

WHEEL DIAMETER	RPM		
	DRY	WET	NOMINAL
6"	1500	2250	1750
8"	1250	1650	1500

* It is suggested to stay under 2,500 SFPM in dry applications and 3,500 SFPM in wet applications

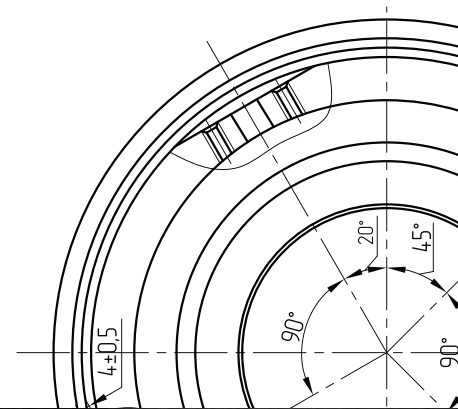

NAMPOWER

WHEEL BRUSHES ARE IDEAL FOR REMOVING SHARP EDGES FROM METAL PARTS AND CREATING A DESIRED EDGE RADIUS.





CUT DEPTH

DIAMETER/GRIT

6" WHEEL

8" WHEEL

.018/500	0.150	0.150
.022/320	0.150	0.150
.022/120	0.150	0.150
.035/180	0.075	0.075
.040/80	0.075	0.075
.040/120	0.075	0.075

*Standard setup is 10% penetration of the available trim length on the smaller diameter filaments and 5% penetration on larger diameter filaments.

FEED RATE

Once brush diameter, grit selection, RPM and depth of cut are established the feed rate can be determined empirically. Set the feed rate at the fastest rate that will produce the desired level of deburring/edge radiusing.

Optimal brush life and finishing properties are obtained by finding the proper balance between brush speed (RPM), part penetration, and line speed. Lower speeds and lighter pressure give longer brush life, generate less heat, and require less power. Where higher brush speeds and pressures are required, it is recommended to use a more aggressive brush tool. Heat adversely affects the life and performance of the nylon filaments. Applying coolant whenever available is recommended.

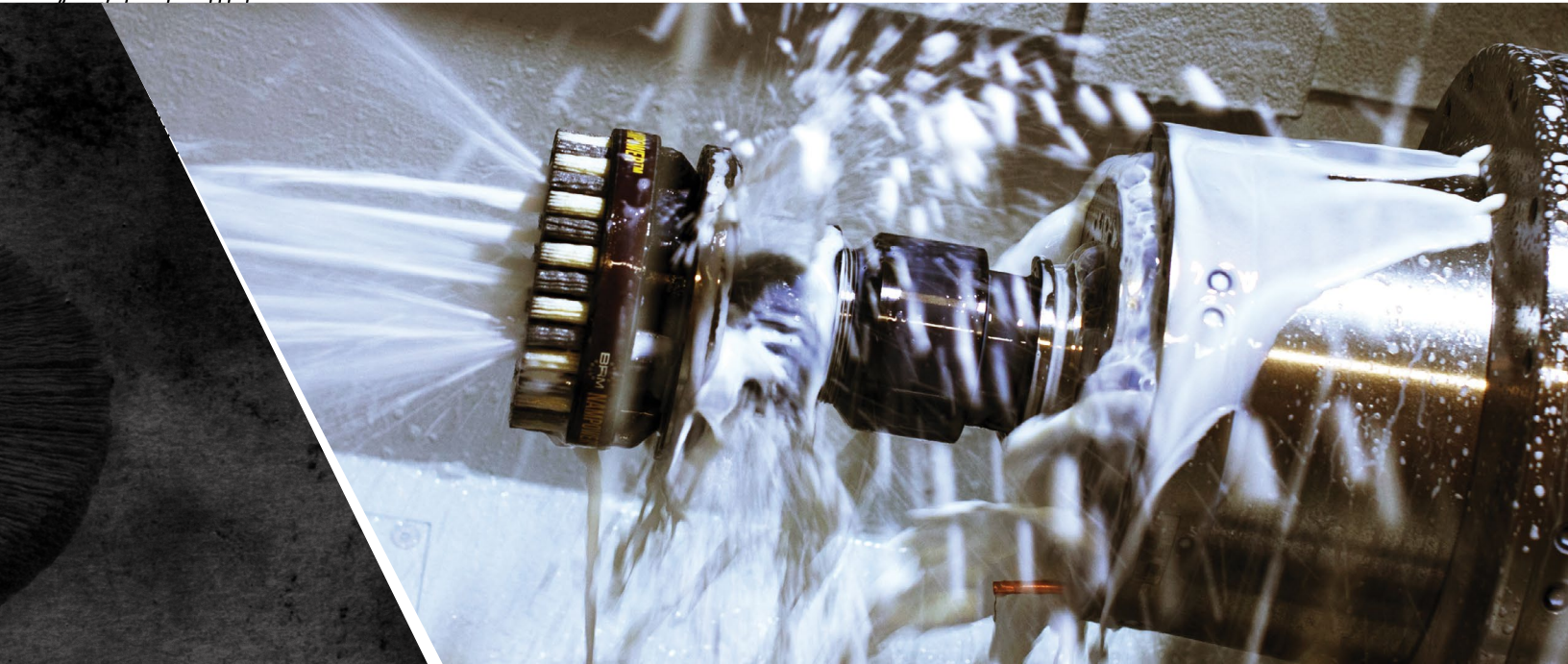
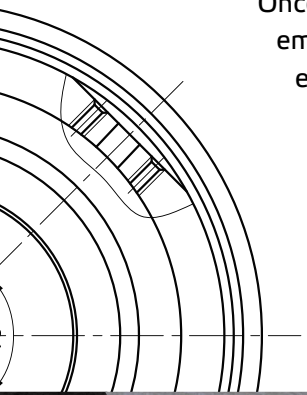



4642 FLORAL DRIVE
LOS ANGELES, CA 90022

