

NOR-LAKE[®] SCIENTIFIC BLOOD BANK REFRIGERATORS

Designed to meet AABB, ANRC and FDA requirements. Advanced engineered design incorporates the latest in cabinet, refrigeration, temperature control and monitoring features. Provides energy efficient, convenient, safe and reliable performance for optimal storage.

Standard Product Features:

- Microprocessor controller with 4x20 character LCD digital display control panel with message center
- Hi/Lo product temperature alarms, audible & visual
- Air probe with air temperature Hi/Lo alarms
- Remote alarm contacts
- Continuous product temperature display
- 2 product sensors with glycerin bottles
- Factory preset temperature at +4°C
- Continuous product temperature display
- Power supply switch
- Temperature chart recorder and chart paper
- 2 levels of user password protection (set points and parameters)
- 100 event alarm logging including date/time stamp and product temperatures. Stored in nonvolatile flash memory
- Integrated Hi/Lo alarm tests
- Door ajar alarm with adjustable delay time period
- Power failure alarm
- 2 to 10 volt DC output for product temperature (selectable to air temperature)
- Digital calibration air and product
- Real time clock with date and time display
- Door opening counter with 24 hour automatic reset
- Adjustable alarm beep or constant on (key pad selectable)
- Alarm volume adjustable manually
- Low battery test switch with buzzer
- Condenser/compressor run time monitor
- Fan motor run time monitor
- Defrost heater time monitor
- Exterior cabinet front, sides and back are painted white
- Exterior cabinet top and bottom are galvanized steel
- Interior cabinet liner is painted white
- Cabinet is foamed-in-place with CFC-free high density polyurethane foam insulation
- Heavy duty door pivot hinges
- Centered key door lock(s) (2 keys)
- Pull door handles, full length, painted white
- Four casters (2 locking) on one door and two door models, six casters (3 locking) on three door models
- 8 solid pull out stainless steel drawers (per door)
- Magnetic door gaskets
- Interior LED light, switch activated
- Air cooled condensing unit
- Top mounted forced air refrigeration system
- Automatic defrost and condensate evaporation
- Sensor access port 1" diameter
- Warranties: 18 month parts and labor, 5 year compressor (US and Canada), 18 months parts (International)
- UL, C-UL listed

Optional Features:

- Legs in lieu of casters
- Shelf
- Wire basket drawer (8 per door)
- Stainless steel exterior
- Stainless steel interior
- 4-20ma output
- RS-485 (modbus-RTU) computer interface
- Export crating



NSBR241WWG/



NSBR241WWG/

NSBR331WWG/

NSBR522WWG/

NSBR803WWG/

NORLAKE SCIENTIFIC



Committed to our environment



Nor-Lake, Inc.
Registered to ISO 9001:2008
File No. 10001816

NOR-LAKE SCIENTIFIC
A Division of
NOR-LAKE, INCORPORATED
727 Second Street
P.O. Box 248
Hudson, Wisconsin 54016
800-477-5253
715-386-2323
800-388-5253 PARTS
715-386-4290 FAX
www.norlakescientific.com

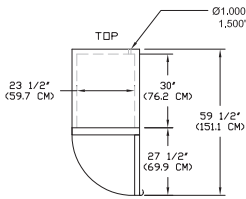

NSBR241WWG/

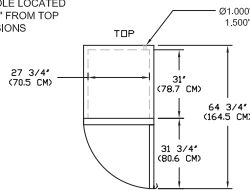

NSBR331WWG/

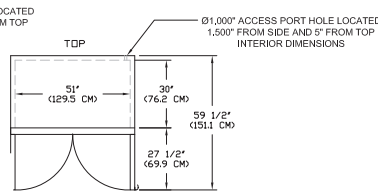

NSBR522WWG/

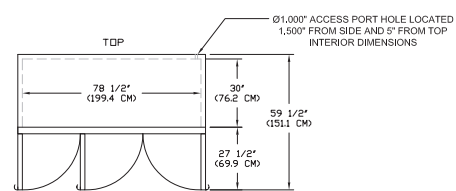

NSBR803WWG/

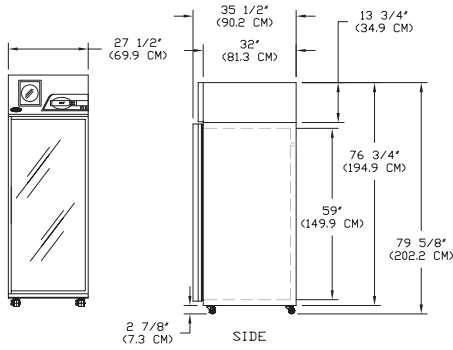

NSBR241WWG/

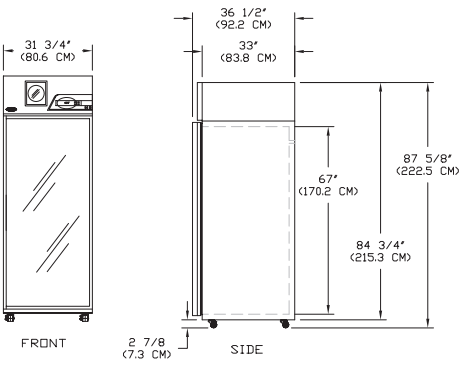

NSBR331WWG/

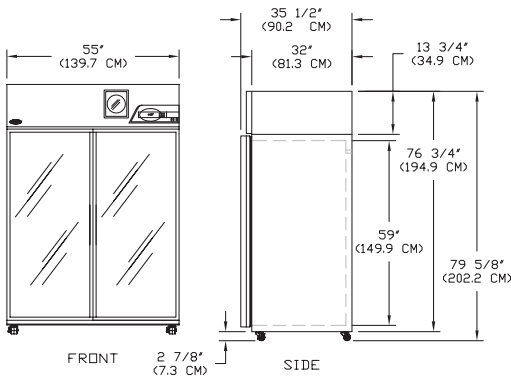

NSBR522WWG/

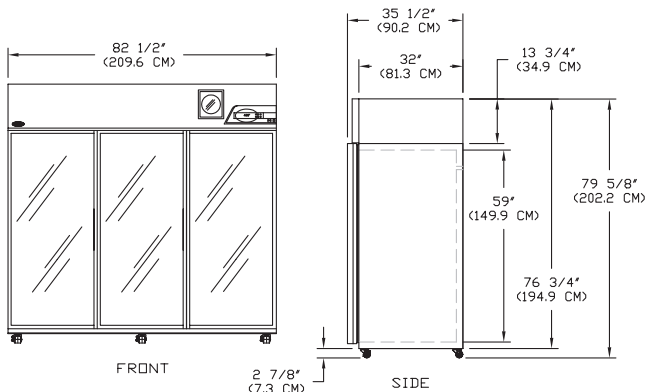

NSBR803WWG/

SPECIFICATIONS

Models	NSBR241WWG/0	NSBR331WWG/0	NSBR522WWG/0	NSBR803WWG/0
	NSBR241WWG/5	NSBR331WWG/5	NSBR522WWG/5	NSBR803WWG/5
Crated Weight (lbs) (kg)	451 (245)	526 (283)	802 (372)	1154 (531)
Crated Height (in) (cm)	83 (208)	91 (233)	83 (208)	83 (208)
Crated Width (in) (cm)	31-7/8 (78)	36-1/4 (89)	59 (149)	86-1/2 (218)
Crated Depth (in) (cm)	38-7/8 (96)	39-3/8 (99)	38-7/8 (96)	38-7/8 (96)
Interior Height (in) (cm)	59 (150)	67 (170)	59 (150)	59 (150)
Interior Width (in) (cm)	23-1/2 (60)	27-3/4 (71)	51 (130)	78-1/2 (199)
Interior Depth (in) (cm)	30 (76)	31 (79)	30 (76)	30 (76)
Overall Height (in) (cm)	79-5/8 (202)	87-5/8 (223)	79-5/8 (202)	79-5/8 (202)
Overall Width (in) (cm)	27-1/2 (70)	31-3/4 (81)	55 (140)	82-1/2 (210)
Overall Depth (in) (cm)	35-1/2 (90)	36-1/2 (92)	35-1/2 (90)	35-1/2 (90)
Gross Cubage (CuFt) (L)	24 (681)	33 (937)	52 (1477)	80 (2272)
450 ML Bag # Units*	416	600	832	1248
Number of Drawers	8	8	16	24
Number of Casters	4	4	4	6
Condensing Unit Size	1/4 HP	1/3 HP	1/3 HP	1/2 HP
Refrigerant	R-134a	R-134a	R-134a	R-134a
Total Amp Draw /0	4.9	8.0	8.0	9.1
Total Amp Draw /5	3.2	3.2	4.2	8.1

Specifications subject to change without notice

* Capacity may vary according to loading preferences and contents

Voltage Model Suffix Code	Voltage Description	NEMA Plug	NEMA Receptacle
/0	115V, 1PH, 60HZ	5-15P	5-15R
/5	230V, 1PH, 50HZ	Power Inlet (IEC 60320) Module	Cord Supplied Locally



NORLAKE SCIENTIFIC

Revision Date: 09/13
 ©2013 NOR-LAKE, INC.
 Printed in the U.S.A.
 Part Number: 090780

