

# NOR-LAKE® SCIENTIFIC

## PREMIER SOLID DOOR LOW TEMPERATURE LABORATORY FREEZER -40°C

Designed to meet the demanding requirements for scientific and laboratory research. Advanced engineered design incorporates the latest in cabinet, refrigeration, temperature control and monitoring features. Provides energy efficient, convenient, safe and reliable performance for optimal storage temperature environments necessary for a wide range of life science, pharmacy, biological, medical, clinical and industrial applications.

### Standard Product Features:

- Digital LED Microprocessor temperature controller with Hi/Lo audible and visual alarm
- Remote alarm contacts
- Adjustable temperature control range from -30°C to -40°C. Factory preset at -35°C
- Continuous product temperature display
- Product sensor with glycerin bottle
- Power supply switch
- Exterior cabinet front, sides and back are painted white
- Exterior cabinet top and bottom are galvanized steel
- Interior cabinet liner and interior door panel are painted white
- Cabinet and solid door are foamed-in-place with CFC Free high density polyurethane foam insulation
- Heavy duty door pivot hinges
- Centered key door lock (2 keys)
- Full length door pull handle
- Four casters (2 locking)
- 3 epoxy coated wire shelves
- Perimeter anti-condensate door frame (temperature selectable) heater wires
- Magnetic door gasket
- Air cooled condensing unit
- Top mounted forced air refrigeration system
- Automatic defrost and condensate evaporation
- Warranties: 18 month parts and labor, 5 year compressor (US and Canada), 18 months parts (International)
- UL/CUL listed

### Optional Features:

- Legs in lieu of casters
- Stainless steel drawer (8 per door)
- Wire basket drawer (6 per door)
- Extra shelf
- Stainless steel exterior
- Stainless steel interior
- 4-20ma output
- Temperature chart recorder with chart paper
- Sensor access port 1" diameter
- Export crating



NSXF221WWW/0



NSXF221WWW/0

NORLAKE SCIENTIFIC



Committed to our environment



Nor-Lake, Inc.  
Registered to ISO 9001:2008  
File No. 10001816

NOR-LAKE SCIENTIFIC  
A Division of  
NOR-LAKE, INCORPORATED  
727 Second Street  
P.O. Box 248  
Hudson, Wisconsin 54016  
800-477-5253  
715-386-2323  
800-388-5253 PARTS  
715-386-4290 FAX  
www.norlakescientific.com

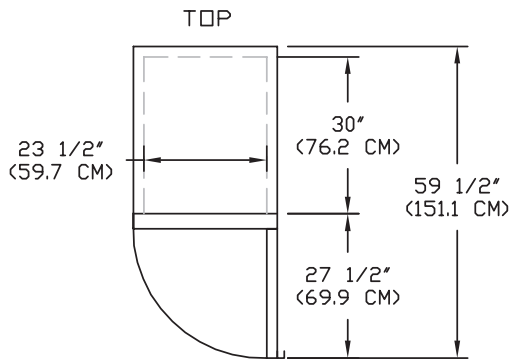

**TOP VIEW - NSXF221WWW/0**

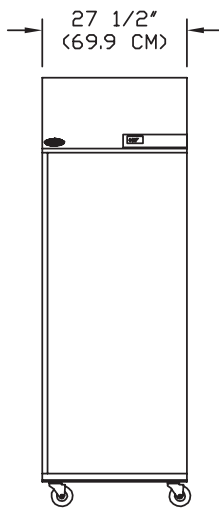

**FRONT VIEW - NSXF221WWW/0**

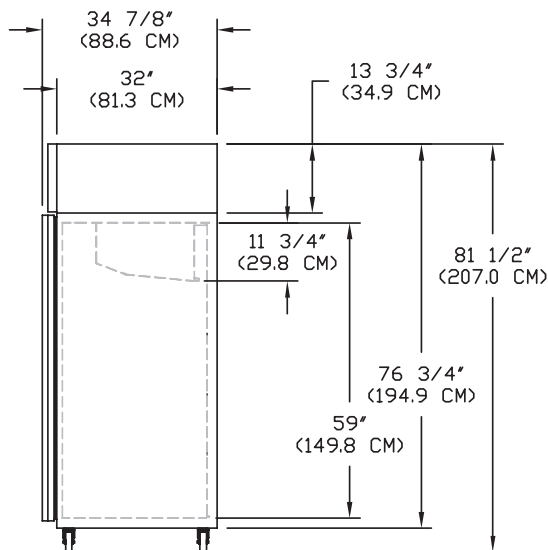

**SIDE VIEW - NSXF221WWW/0**

**SPECIFICATIONS**

<b>Model</b>	<b>NSXF221WWW/0</b>
<b>Crated Height (in) (cm)</b>	84-7/8" (216)
<b>Crated Width (in) (cm)</b>	37" (94)
<b>Crated Depth (in) (cm)</b>	41" (104)
<b>Crated Weight (lbs) (kg)</b>	485 (220)
<b>Interior Height (in) (cm)</b>	59" (149)
<b>Interior Width (in) (cm)</b>	23-1/2" (59)
<b>Interior Depth (in) (cm)</b>	30" (76)
<b>Overall Height (in) (cm)</b>	81-1/2" (207)
<b>Overall Width (in) (cm)</b>	27-1/2" (69)
<b>Overall Depth (in) (cm)</b>	34-7/8" (90)
<b>Gross Cubage (ft.<sup>3</sup>) (L)</b>	22 (623)
<b>Shelf Area (sq. ft.) (m<sup>2</sup>)</b>	18.3 (1.7)
<b>Number of Shelves</b>	3
<b>Number of Casters</b>	4
<b>Condensing Unit Size</b>	3/4 HP
<b>Refrigerant</b>	R-404A
<b>Electrical Characteristics</b>	115/60/1
<b>Cord and Plug Supplied</b>	Yes
<b>Maximum Fuse Size</b>	20 Amps
<b>Total Amp Draw /0</b>	14.3

Specifications subject to change without notice.

<b>Voltage Model Suffix Code</b>	<b>Voltage Description</b>	<b>NEMA Plug</b>	<b>NEMA Receptacle</b>
/0	115V, 1PH, 60HZ	5-20P	5-20R

**NORLAKE SCIENTIFIC**

Revision Date: 05/12  
 ©2012 NOR-LAKE, INC.  
 Printed in the U.S.A.  
 Part Number: 143165

**Standex**  
 Food Service Equipment Group