

# NOR-LAKE<sup>®</sup> SCIENTIFIC

## PREMIER LABORATORY AND PHARMACY FREEZERS

Designed to meet the demanding requirements for scientific and laboratory research. Advanced engineered design incorporates the latest in cabinet, refrigeration, temperature control and monitoring features. Provides energy efficient, convenient, safe and reliable performance for optimal storage temperature environments necessary for a wide range of life science, pharmacy, biological, medical, clinical, and industrial applications.

### Standard Product Features:

- Digital LED display microprocessor temperature controller
- Audible and visual Hi/Lo temperature alarm
- Adjustable control range from -10°C to -25°C factory preset at -20°C
- Remote alarm contacts
- Continuous product temperature display
- Product sensor with glycerin bottle
- Power supply switch
- Exterior cabinet front, sides and back are painted white
- Exterior cabinet top and bottom are galvanized steel
- Interior cabinet liner and interior door panel are painted white
- Cabinet and solid door are foamed-in-place with CFC Free high density polyurethane foam insulation
- Heavy duty solid door(s) with pivot hinges
- Full length pull door handle(s)
- Magnetic door gaskets
- Centered key door lock(s) (2 keys)
- Four casters on one and two door models (2 locking), six casters (3 locking) on three door models
- 3 coated wire shelves per door section
- Perimeter anti-condensate door frame heater wires
- Interior light, switch activated
- Air cooled condensing unit
- Top mounted forced air refrigeration system
- Automatic defrost and condensate evaporation
- Warranties: 18 month parts and labor, 5 year compressor (US and Canada), 18 months parts (International)
- UL/CUL listed

### Optional Features:

- Extra shelf
- Stainless steel drawer (8 maximum per door)
- Wire basket drawer (8 maximum per door)
- Sensor access port 1" diameter
- Legs in lieu of casters
- Stainless steel interior
- Stainless steel exterior
- Reverse door hinge
- Temperature chart recorder with chart paper
- 4-20ma output
- Export crating



NSPF241WWW/

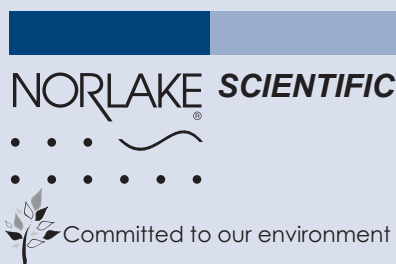

Nor-Lake, Inc.  
Registered to ISO 9001:2008  
File No. 10001816

NOR-LAKE SCIENTIFIC  
A Division of  
NOR-LAKE, INCORPORATED  
727 Second Street  
P.O. Box 248  
Hudson, Wisconsin 54016  
800-477-5253  
715-386-2323  
800-388-5253 PARTS  
715-386-4290 FAX  
www.norlakescientific.com

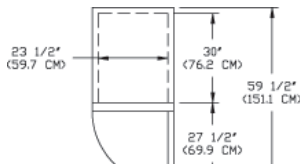

NSPF241WWW/0

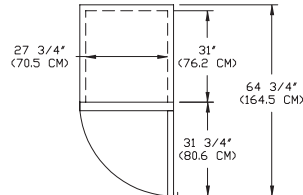

NSPF331WWW/0

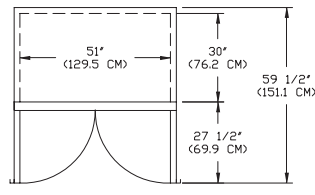

NSPF522WWW/0

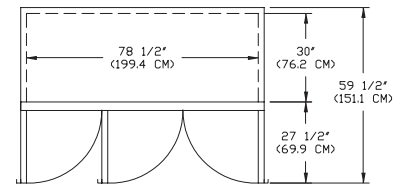

NSPF803WWW/0

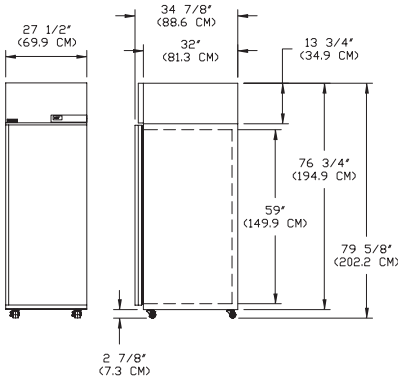

NSPF241WWW/0

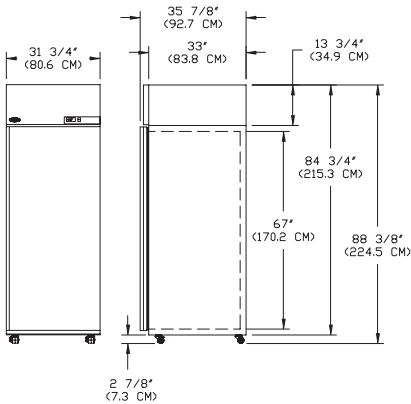

NSPF331WWW/0

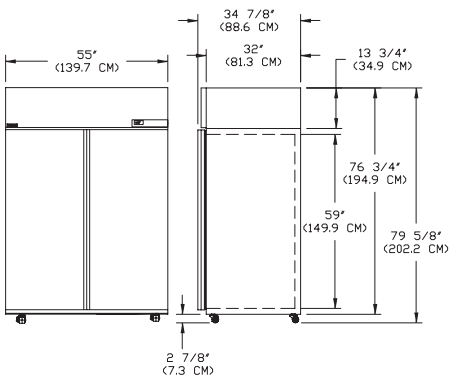

NSPF522WWW/0

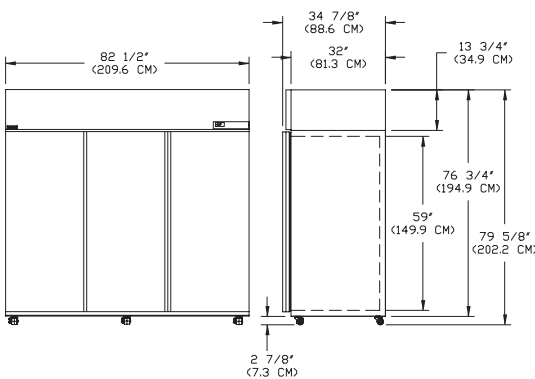

NSPF803WWW/0

FRONT

SIDE

## SPECIFICATIONS

Models	NSPF241WWW/0	NSPF331WWW/0*	NSPF522WWW/0*	NSPF803WWW/0*
	NSPF241WWW/5	NSPF331WWW/5	NSPF522WWW/5	NSPF803WWW/5
Crated Height (in) (cm)	83" (212)	91" (233)	83" (212)	83" (212)
Crated Width (in) (cm)	31-7/8" (96)	36-1/4" (89)	59" (149)	86-1/2" (218)
Crated Depth (in) (cm)	38-7/8" (101)	39-7/8" (99)	40" (101)	38-7/8" (96)
Crated Weight (lbs) (kg)	375 (170)	402 (199)	552 (268)	787 (365)
Interior Height (in) (cm)	59" (149.9)	67" (170)	59" (149)	59" (149)
Interior Width (in) (cm)	23-1/2" (59.7)	27-3/4" (70)	51" (129)	78-1/2" (199)
Interior Depth (in) (cm)	30" (76.2)	31" (78)	30" (76)	30" (76)
Overall Height (in) (cm)	79-5/8" (202)	87-5/8" (224)	79-5/8" (202)	79-5/8" (202)
Overall Width (in) (cm)	27-1/2" (69)	31-3/4" (80)	55" (139)	82-1/2" (209)
Overall Depth (in) (cm)	34-7/8" (88)	35-7/8" (91)	34-7/8" (88)	34-7/8" (88)
Gross Cubage (ft.3) (m3)	24.0 (0.6)	33.1 (0.9)	52.0 (1.4)	80.0 (2.2)
Shelf Area (sq. ft.) (m <sup>2</sup> )	12.83 (1.1)	15.85 (1.4)	28.6 (2.6)	42.84 (3.9)
Number of Shelves	3	3	6	9
Number of Casters	4	4	4	6
Condensing Unit Size	1/2	1/2	3/4	1
Refrigerant	R-404A	R-404A	R-404A	R-404A
Maximum Fuse Size	15 AMPS	20 AMPS	20 AMPS	20 AMPS
Total Amp Draw /0	9.7	12.3*	12.4*	13.8*
Total Amp Draw /5	5.2	5.9	8.96	6.49

Specifications subject to change without notice.

Voltage/Model Suffix Code	Voltage Description	NEMA Plug	NEMA Receptacle
/0	115V, 1PH, 60HZ	5-15P	5-15R
/0*	115V, 1PH, 60HZ	5-20P	5-20R
/5	230V, 1PH, 50HZ	Power Inlet (IEC60320) Module	Cord Supplied Locally

**NORLAKE SCIENTIFIC**

Revision Date: 04/12  
 ©2012 NOR-LAKE, INC.  
 Printed in the U.S.A.  
 Part Number: 073276

