

NOR-LAKE[®] SCIENTIFIC

SELECT[™] LABORATORY AND PHARMACY FREEZERS

Designed to meet the demanding requirements for scientific and laboratory research. Advanced engineered design incorporates the latest in cabinet, refrigeration, temperature control and monitoring features. Provides energy efficient, convenient, safe and reliable performance for optimal storage temperature environments necessary for a wide range of life science, pharmacy, biological, medical, clinical, and industrial applications.

Standard Product Features:

- Digital 4x20 character LCD display microprocessor temperature controller
- Audible and visual Hi/Lo temperature alarm
- Adjustable control range from -10°C to -25°C; factory preset at -25°C
- Remote alarm contacts
- Continuous product temperature display
- 3 sensor system, 2 product, 1 air
- Power supply switch
- Door ajar alarm, audible and visual
- Audible and visual Hi/Lo air and product temperature alarms
- 2 to 10 volt DC output for product temperature (selectable to air temperature)
- Password protection- set-points and factory settings
- 100 event alarm logging
- Integrated Hi/Lo product temperature alarm test
- Digital calibration air and product
- Real time clock with date and time display
- Door opening counter with 24 hour automatic reset
- Adjustable alarm beep or constant on (key pad selectable)
- Alarm volume adjustable manually
- Low battery test switch with buzzer
- Condenser/compressor run time monitor
- Fan motor run time monitor
- Defrost heater time monitor
- Condenser/compressor run time monitor
- Perimeter anti-condensate door frame heater wires
- Sensor failure alarm
- Exterior cabinet front, sides and back are painted white
- Exterior cabinet top and bottom are galvanized steel
- Interior cabinet liner and interior door panel are painted white
- Cabinet and solid door are foamed-in-place with CFC Free high density polyurethane foam insulation
- Heavy duty solid door(s) with pivot hinges
- Full length pull door handle(s)
- Magnetic door gaskets
- Centered key door lock(s) (2 keys)
- Four casters on one and two door models (2 locking), Six casters (3 locking) on three door models
- 3 coated wire shelves per door section
- Interior light, switch activated
- Air cooled condensing unit
- Top mounted forced air refrigeration system
- Automatic defrost and condensate evaporation
- Sensor access port, 1" diameter
- Warranties: 24 months parts and labor, 5 year compressor (US and Canada) 18 months parts (International)
- UL/CUL listed

Optional Features:

- Extra shelf
- Stainless steel drawer (8 maximum)
- Wire basket drawer (8 maximum)
- Legs 6" in lieu of casters
- Stainless steel interior
- Stainless steel exterior
- Reverse hinge door
- Temperature chart recorder with chart paper
- 4-20ma output for product temperature (selectable to air temperature)
- RS-485 digital communications port (MODBUS-RTU)
- Ethernet 10 baseT (HTTP) control monitoring web card
- Secure Guard II[™] Lock ProxKey (Factory Installed)
- Secure Guard II[™] MagKey (Factory Installed)
- Secure Guard II[™] Lock Software
- Seismic mounting kit
- Export crating

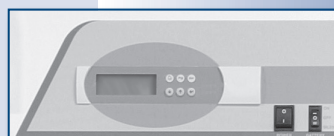

NORLAKE SCIENTIFIC



Committed to our environment



Nor-Lake, Inc.
Registered to ISO 9001:2008
File No. 10001816

NOR-LAKE SCIENTIFIC
A Division of
NOR-LAKE, INCORPORATED
727 Second Street
P.O. Box 248
Hudson, Wisconsin 54016
800-477-5253
715-386-2323
800-388-5253 PARTS
715-386-4290 FAX
www.norlakescientific.com

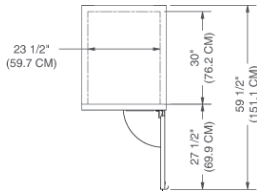

NSSF241WWW/

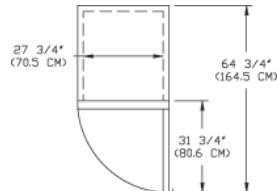

NSSF331WWW/

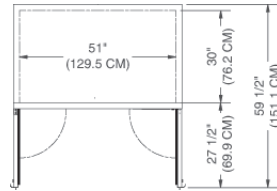

NSSF522WWW/

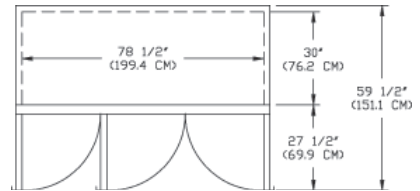

NSSF803WWW/

SPECIFICATIONS

Models	NSSF241WWW/0	NSSF331WWW/0*	NSSF522WWW/0*	NSSF803WWW/0*
	NSSF241WWW/4	NSSF331WWW/4	NSSF522WWW/4	NSSF803WWW/4
	NSSF241WWW/5	NSSF331WWW/5	NSSF522WWW/5	NSSF803WWW/5
Crated Height (in) (cm)	83-7/8" (212)	91-5/8" (233)	83-7/8" (212)	83-7/8" (212)
Crated Width (in) (cm)	31-7/8" (96)	36-1/4" (89)	59" (149)	85-1/4" (218)
Crated Depth (in) (cm)	39" (101)	39-1/2" (99)	39" (101)	38" (96)
Crated Weight (lbs) (kg)	375 (170)	439 (199)	590 (268)	805 (365)
Interior Height (in) (cm)	59" (149)	67" (170)	59" (149)	59" (149)
Interior Width (in) (cm)	23-1/2" (59)	27-3/4" (70)	51" (129)	78-1/2" (199)
Interior Depth (in) (cm)	30" (76)	31" (78)	30" (76)	30" (76)
Overall Height (in) (cm)	79-5/8" (202)	87-5/8" (224)	79-5/8" (202)	79-5/8" (202)
Overall Width (in) (cm)	27-1/2" (69)	31-3/4" (80)	55" (139)	82-1/2" (209)
Overall Depth (in) (cm)	34-7/8" (88)	35-7/8" (91)	34-7/8" (88)	34-7/8" (88)
Gross Cubage (ft.3) (L)	24.0 (681)	33.1 (937)	52.0 (1476)	80.0 (2272)
Number of Shelves	3	3	6	9
Shelf Area (ft ²) (m ²)	12.83 (1.1)	15.85 (1.4)	28.6 (2.6)	42.84 (3.9)
Number of Casters	4	4	4	6
Condensing Unit Size	1/2 HP	1/2 HP	3/4 HP	1 HP
Refrigerant	R-404a	R-404a	R-404a	R-404a
Maximum Fuse Size	15 Amps	20 Amps	20 Amps	20 Amps
Total Amp Draw /0	9.7	12.3*	12.4*	13.8*
Total Amp Draw /4	5.1	5.1	6.1	6.9
Total Amp Draw /5	3.9	3.9	5.0	5.4

Specifications subject to change without notice.

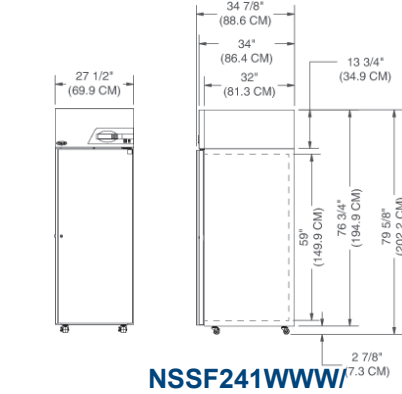

NSSF241WWW/

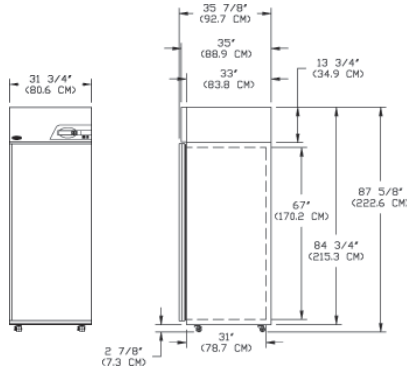

NSSF331WWW/

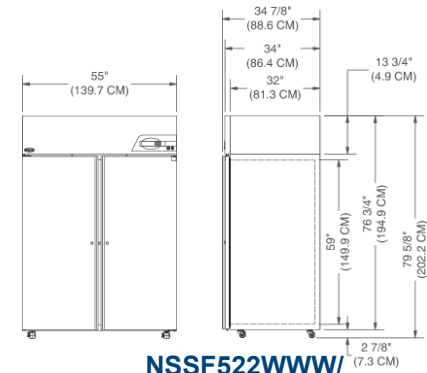

NSSF522WWW/

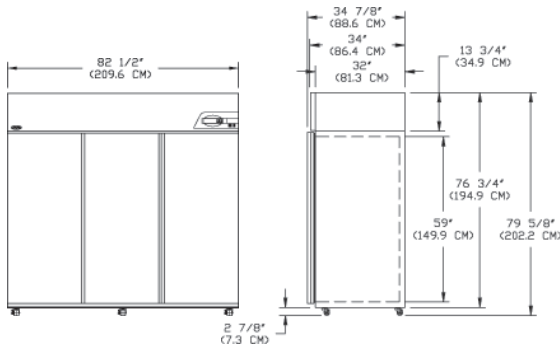

NSSF803WWW/

FRONT

SIDE

Voltage Model Suffix Code	Voltage Description	NEMA Plug	NEMA Receptacle
/0	115V, 1PH, 60HZ	5-15P	5-15R
/0*	115V, 1PH, 60HZ	5-20P	5-20R
/4	208/230, 1PH, 60HZ	6-15P	6-15R
/5	230V, 1PH, 50HZ	Power Inlet (IEC 60320) Module	Cord Supplied Locally



NORLAKE SCIENTIFIC

Revision Date: 05/13
 ©2013 NOR-LAKE, INC.
 Printed in the U.S.A.
 Part Number: 143229

