

Rittal – The System.

Faster – better – worldwide.



Schaltschrank-Kühlgerät
Cooling unit
Climatiseur
Koelaggregat
Kylaggregat
Condizionatori per armadi di comando
Refrigerador para armarios
エンクロージャー用クーリングユニット

SK 3302.xxx
SK 3302.3xx
SK 3303.xxx
SK 3304.xxx
SK 3305.xxx

SK 3328.xxx
SK 3329.xxx
SK 3332.xxx
SK 3361.xxx
SK 3366.xxx

Montage-, Installations- und Bedienungsanleitung
Assembly and operating instructions
Manuel d'installation et de maintenance
Montage- en bedieningshandleiding
Montage- och hanteringsanvisning
Istruzioni di montaggio e funzionamento
Instrucciones de montaje
取扱説明書

ENCLOSURES

POWER DISTRIBUTION

CLIMATE CONTROL

IT INFRASTRUCTURE

SOFTWARE & SERVICES

FRIEDHELM LOH GROUP



Contents

1	Notes on documentation	4	5	Commissioning	20
1.1	Associated documents	4	6	Operation	21
1.2	CE labelling	4	6.1	Control using the Basic controller	21
1.3	Retention of documents	4	6.1.1	Properties	21
1.4	Symbols used	4	6.1.2	Operating and error display	22
2	Safety instructions	4	6.1.3	Test mode for the Basic controller	23
3	Device description	5	6.1.4	Setting the temperature	23
3.1	Functional description	5	6.1.5	Resetting the Basic controller	23
3.1.1	How it works	5	6.2	Control using the e-Comfort controller	23
3.1.2	Control	5	6.2.1	Properties	23
3.1.3	Bus mode (e-Comfort controller only)	5	6.2.2	Eco-mode	24
3.1.4	Safety equipment	6	6.2.3	Launching test mode	24
3.1.5	Condensation	6	6.2.4	General programming information	24
3.1.6	Filter mats	6	6.2.5	Editable parameters	25
3.1.7	Door limit switch	6	6.2.6	Programming overview	26
3.1.8	Additional interface X3	7	6.2.7	Defining system messages for evaluation	27
3.2	Proper usage	7	6.2.8	Setting the master-slave identifier	28
3.3	Scope of supply	7	6.2.9	Evaluating system messages	28
4	Assembly and connection	7	6.2.10	Resetting the e-Comfort controller	30
4.1	Choosing the installation site	7	7	Inspection and maintenance	30
4.2	Assembly instructions	7	7.1	General	30
4.2.1	General	7	7.1.1	Compressed air cleaning SK 3304.xxx, SK 3305.xxx	30
4.2.2	Layout of the electronic components in the enclosure	8	7.1.2	Compressed air cleaning SK 3328.xxx, SK 3329.xxx, SK 3332.xxx	34
4.3	Fitting the cooling unit	8	8	Storage and disposal	39
4.3.1	Cutting out on the enclosure	9	9	Technical specifications	39
4.3.2	External mounting of the cooling unit	9	10	List of spare parts	43
4.3.3	Partial internal mounting of the cooling unit	9	11	Appendix: Cut-out and hole sizes	47
4.3.4	Full internal mounting of the cooling unit	11	11.1	Dimensions for external mounting	47
4.4	Connecting the condensate discharge	12	11.2	Dimensions for partial internal mounting	48
4.5	Notes on electrical installation	12	11.3	Dimensions for full internal mounting	49
4.5.1	Connection data	12			
4.5.2	Overvoltage protection and supply line load	12			
4.5.3	Three-phase devices	12			
4.5.4	Door limit switch	13			
4.5.5	Notes on the flicker standard	13			
4.5.6	Potential equalisation	13			
4.6	Carrying out the electrical installation	13			
4.6.1	Bus connection (only in conjunction with several units with an e-Comfort controller)	13			
4.6.2	Connection X3 for serial interface	13			
4.6.3	Installing external transformers	13			
4.6.4	Installing the power supply	14			
4.7	Finalising assembly	20			
4.7.1	Installing the filter media	20			
4.7.2	Fitting the cooling unit	20			
4.7.3	Setting the filter mat monitor (only with e-Comfort controller)	20			

1 Notes on documentation

1 Notes on documentation

These assembly instructions are aimed at tradespersons who are familiar with assembly and installation of the cooling unit, and at trained specialists who are familiar with operation of the cooling unit.

1.1 Associated documents

There are two sets of instructions for the unit types described here:

- Assembly and installation instructions enclosed with the unit in the form of a paper document
- Assembly, installation and operating instructions enclosed with the unit in the form of a PDF file (Adobe Acrobat) on CD-ROM

We cannot accept any liability for damage associated with failure to observe these instructions. Where applicable, the instructions for any accessories used also apply.

1.2 CE labelling

The declaration of conformity is supplied with the unit as a separate document.

1.3 Retention of documents

These instructions and all associated documents constitute an integral part of the product. They must be given to the plant operator. The plant operator is responsible for storage of the documents so they are readily available when needed.

1.4 Symbols used

Please observe the following safety instructions and other notes in this guide:

Symbol for an instructed action:

- The bullet point indicates that you should perform an action.

Safety and other instructions:



Danger!
Immediate danger to life and limb!



Caution!
Potential threat to the product and its environment.



Note:
Useful information and special features.

2 Safety instructions

Please observe the following general safety instructions when assembling and operating the unit:

- Assembly, installation and servicing may only be performed by properly trained specialists.
- Screw the enclosure to the floor to prevent it from tipping over when the cooling unit is installed.
- Do not obstruct the air inlet and air outlet of the cooling unit inside and outside the enclosure (see also section 4.2.2).
- To ensure problem-free opening and closing of the enclosure door, use a ride-up door roller (refer to the accessories in the Rittal Catalogue). This raises the door slightly and balances out the weight of the cooling unit, to prevent buckling of the door and associated seal problems.
- The heat loss of the components installed in the enclosure must not exceed the specific useful cooling output of the cooling unit.
- When transporting the enclosure with the cooling unit externally mounted, always use an additional shipping brace to support the cooling unit.
- The cooling unit must always be transported in an upright position.
- Use only original spare parts and accessories.
- Do not make any changes to the cooling unit other than those described in these instructions or associated instructions.
- Risk of burn injuries! For cooling units with automatic condensate evaporation, the surface of the thermal element will get very hot during operation, and will remain so for some time afterwards.
- The mains connector of the cooling unit must only be connected and disconnected with the system de-energised. Connect the pre-fuse specified on the rating plate.

3 Device description

Depending on the model chosen, your cooling unit may vary in appearance from the illustrations contained in these instructions. However, the functions are identical in principle.

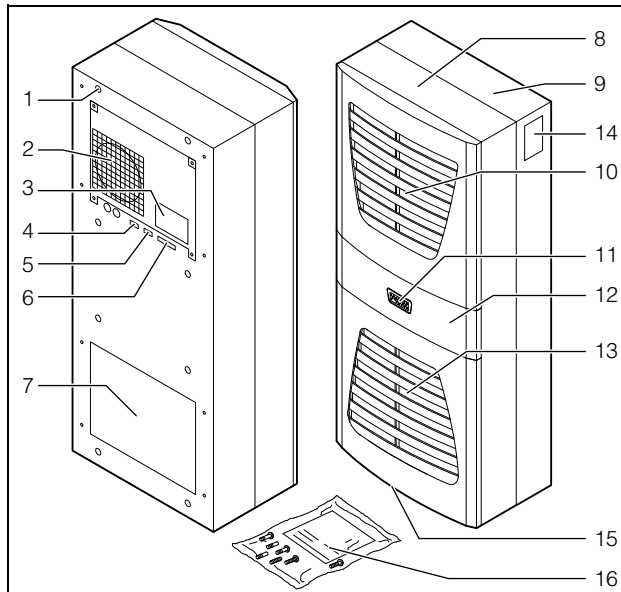

Fig. 1: Device description

Legend

- 1 Blind rivet nut
- 2 Evaporator fan
- 3 Electrical wiring plan
- 4 X2 master-slave connection
- 5 X3 optional serial interface
- 6 X1 terminal strip
- 7 Air outlet hole
- 8 Front half of the enclosure
- 9 Rear half of the enclosure
- 10 Louvred grille for air outlet
- 11 Display
- 12 Infill panel
- 13 Louvred grille for air inlet
- 14 Rating plate
- 15 Condensate discharge
- 16 Dispatch bag

3.1 Functional description

Enclosure cooling units are designed to dissipate heat from enclosures by cooling the air inside the enclosure and so protect the temperature-sensitive components. They are built into the side or rear panel or into the door of the enclosure.

3.1.1 How it works

The cooling unit (compression refrigeration system) is comprised of four main components (cf. Fig. 2): the evaporator (1), the coolant compressor (2), the condenser (3), and the control or expansion valve (4), which are connected by suitable pipework. This circuit is filled with a readily boiling substance, the refrigerant. Coolant R134a (CH_2FCF_3) is chlorine-free. Its ozone destruction potential is 0, making it very eco-friendly. A filter dryer (5) which is integrated

into the hermetically sealed cooling circuit provides effective protection against moisture, acid, dirt particles, and foreign bodies within the cooling circuit.

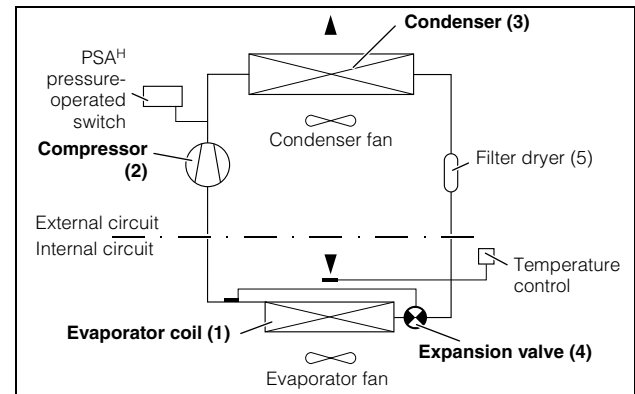

Fig. 2: Cooling circuit

In the evaporator coil (1), the liquid coolant is converted to a gaseous state. The energy needed for this purpose is taken from the enclosure air in the form of heat, which has the effect of cooling the enclosure air. In the compressor (2), the coolant is heavily compressed, so that it achieves a higher temperature inside the condenser (3) than the ambient air. This means that excess heat may be emitted to the ambient air via the surface of the condenser, as a result of which the temperature of the coolant drops and it is converted back into liquid. It is re-injected into the evaporator coil via a thermostatic expansion valve (4), which causes it to cool down further, and is then once again able to absorb the energy from the enclosure air in the evaporator coil. The whole cycle begins again.

3.1.2 Control

Rittal enclosure cooling units are fitted with a controller for setting the functions of the cooling unit. Depending on the design, this is either a Basic controller (display of the operating status via LED) or a e-Comfort controller (display plus extended functions, see chapter "6 Operation", page 21).

3.1.3 Bus mode (e-Comfort controller only)

The serial unit interface X2 allows you to create a bus connection with up to ten cooling units using the master-slave cable (shielded, four-wire cable, Model No. SK 3124.100). This allows you to implement the following functions:

- Parallel unit control (the cooling units in the network can be switched on and off simultaneously)
 - Parallel door status message ("door open")
 - Parallel collective fault message
- Data is exchanged via the master-slave connection. During commissioning, assign an address to each unit that also includes the identifier "master" or "slave".

3 Device description

EN

3.1.4 Safety equipment

- In the cooling cycle, the cooling unit has a tested pressure-operated switch to EN 12 263 which is set to maximum PS (admissible pressure); this operates via an automatic reset device whenever the pressure drops again.
- Temperature monitoring prevents the evaporator coil from icing over. If there is a risk of icing, the compressor switches itself off and automatically switches itself back on again at higher temperatures.
- The refrigerant compressor and the fans are equipped with thermal winding shields to protect against excess current and excess temperatures.
- In order to allow a reduction of pressure inside the compressor and hence a safe restart, once it has been switched off (e.g. upon reaching the set temperature via the door limit switch function or via de-energising), the device will switch back on with a delay of 180 seconds.
- The device has floating contacts on the connection pins (terminals 3 – 5), via which system messages from the device may be polled, e.g. using a PLC (1x change-over contact Basic controller, 2 x normally open contacts e-Comfort controller).

3.1.5 Condensation

At high levels of humidity and low temperatures inside the enclosure, condensation may form on the evaporator coil.

The cooling units (except SK 3302.xxx, SK 3303.xxx and SK 3361.xxx) have automatic, electric condensate evaporation. The thermal component used for this purpose is based on self-regulating PTC technology. Condensate arising on the evaporator coil is collected in a tank in the external circuit of the cooling unit, and partially evaporated via the airflow. When the water level rises, the water enters the PTC thermal component and is evaporated (through-flow heater principle). The water vapour streams out of the cooling unit with the airflow from the external fan. The PTC thermal component is permanently connected and has no switchpoint. It is protected against short-circuits with miniature fuses (F1.1, F1.2). If the fuse has tripped, any condensation is drained off via the safety overflow.

For unit types SK 3302.xxx, SK 3303.xxx and SK 3361.xxx, the condensation is routed downwards out of the unit via a drain pipe on the evaporator coil divider panel. For this purpose, a hose must be connected to the condensate nozzle (see “4.4 Connecting the condensate drain”, page 12). External condensate evaporators are available as accessories for these unit types (refer also to the accessories in the Rittal Catalogue).

3.1.6 Filter mats

The cooling unit condenser is finished all over with a dirt-repelling, easy-to-clean RiNano coating. In many cases, therefore, the use of filter media is unnecessary, particularly in the case of dry dusts.

For dry, coarse dust and lint in the ambient air, we recommend installing an additional PU foam filter mat (available as an accessory) in the cooling unit. Depending on the incidence of dust, you will need to replace the filter from time to time.

For air containing oil condensation, we recommend the use of metal filters (also available as an accessory). These may be cleaned with suitable detergents and reused.

Function of the filter mat monitor:

Dirt on the filter mat is automatically determined by measuring the temperature difference in the external circuit of the cooling unit. As the level of filter mat soiling rises, the temperature difference will increase. The nominal value of the temperature difference in the external circuit adapts automatically to the relevant operating points in the performance diagrams. Hence there is no need to readjust the nominal value for different operating points of the cooling unit.

3.1.7 Door limit switch

The cooling unit may be operated with a floating door limit switch connected. The door limit switch is not included with the supply (available as an accessory, Model No. PS 4127.010).

The door limit switch function causes the fans and the compressor in the cooling unit to be switched off after approximately 15 seconds when the enclosure door is opened (contacts 1 and 2 closed). This prevents the formation of condensation inside the enclosure while the enclosure door is open. In order to prevent damage to the unit, it is equipped with an ON delay: The evaporator fan cuts back in with a delay of approximately 15 seconds after the door has been closed, while the condenser fan and compressor switch on after approximately 3 minutes.



Note:

- No external voltage must be applied to the door contacts (terminals 1 and 2).
- For Basic controller cooling units with 230/115 V and 400 V/2-phase connection, the evaporator fan remains operational even with the door open.

3.1.8 Additional interface X3



Note:

The electrical signals at the interface are of an extra-low voltage (not extra-low safety voltages to EN 60 335).

An additional interface card may be connected to the 9-pole SUB-D connector X3 in order to incorporate the cooling unit into higher-level monitoring systems (available as an accessory, interface card Model No. SK 324.200).

3.2 Proper usage

Rittal enclosure cooling units were developed and designed in accordance with the state-of-the-art and the recognised rules governing technical safety. Nevertheless, if used improperly, they may pose a threat to life and limb or cause damage to property. The unit is only intended for cooling enclosures. Any other use is deemed improper. The manufacturer will not be liable for any damages caused as a result of improper use, or for incorrect assembly, installation or use. All risk is borne solely by the user.

Proper usage also includes the observation of all valid documents and compliance with the inspection and servicing conditions.

3.3 Scope of supply

The unit is supplied in a packaging unit in a fully assembled state.

Please check the delivery for completeness:

Qty.	Description
1	Enclosure cooling unit
1	Dispatch bag:
1	– Assembly and installation instructions
1	– Assembly, installation and operating instructions on CD-ROM
1	– Safety instructions
1	– Self-adhesive tape
1	– Connector X1
4 – 10	– Self-tapping screws
1	– Declaration of conformity
	– Nuts, washers
1	Drilling template

Tab. 1: Scope of supply

4 Assembly and connection

4.1 Choosing the installation site

When choosing the installation site for the enclosure, please observe the following:

- The site for the enclosure, and hence the arrangement of the cooling unit, must be carefully selected so as to ensure good ventilation (distances between units and distances between the unit and the wall must be at least 200 mm in each case).
- The cooling unit must be installed and operated in a vertical position (maximum deviation: 2°).
- The site must be free from excessive dirt and moisture.
- The ambient temperature must not exceed 55°C.
- It must be possible to fit a condensate discharge (see “4.4 Connecting the condensate discharge”, page 12).
- The mains connection data as stated on the rating plate of the unit must be guaranteed.

4.2 Assembly instructions

4.2.1 General

- Check the packaging carefully for signs of damage. Traces of oil on damaged packaging are an indication of refrigerant loss and leakages. Packaging damage may be the cause of a subsequent functional failure.
- The enclosure must be sealed on all sides (IP 54). Increased condensation will occur if the enclosure is not airtight.
- In order to avoid excessive condensation inside the enclosure, we recommend installing a door limit switch (e.g. PS 4127.010) which deactivates the cooling unit when the enclosure door is opened (see “3.1.7 Door limit switch”, page 6).

4 Assembly and connection

4.2.2 Layout of the electronic components in the enclosure



Caution!

Risk of condensation!

When arranging the components inside the enclosure, please ensure that the cold airflow from the cooling unit is not directed at active components. Please also ensure that the cold airflow is not directed at the warm exhaust airflow from active components such as converters. This may lead to an air short-circuit and therefore prevent adequate climate control, or may even cause the cooling unit's internal safety devices to cease cooling operation.

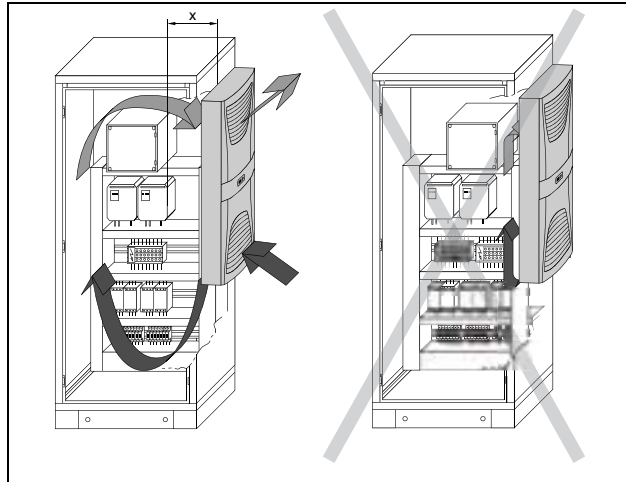

Fig. 4: Air circulation inside the enclosure

4.3 Fitting the cooling unit

The enclosure cooling unit may optionally be externally mounted on the enclosure (1), partially internally mounted (2) or fully internally mounted (3):

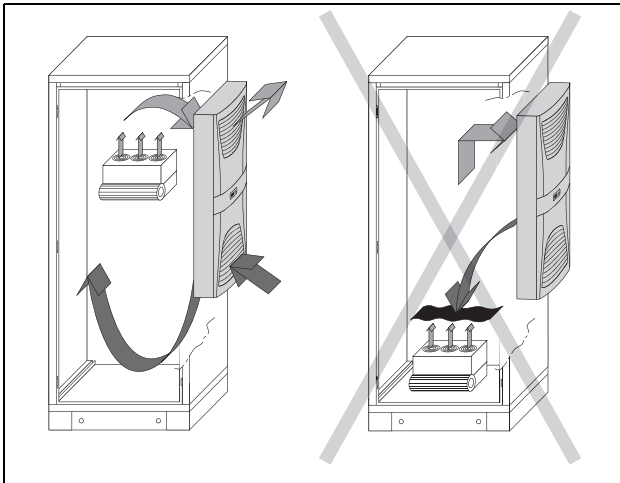

Fig. 3: Never direct the cold airflow at active components

Air diversion components are available as accessories – please refer to the Rittal catalogue.

It is important to ensure even air circulation inside the enclosure. Under no circumstances should air inlet and outlet openings be obstructed, otherwise the cooling performance of the unit will be reduced. Ensure the distance “x” (see Fig. 4) from electronic components and other installed enclosures so that the required air circulation is not obstructed and prevented.

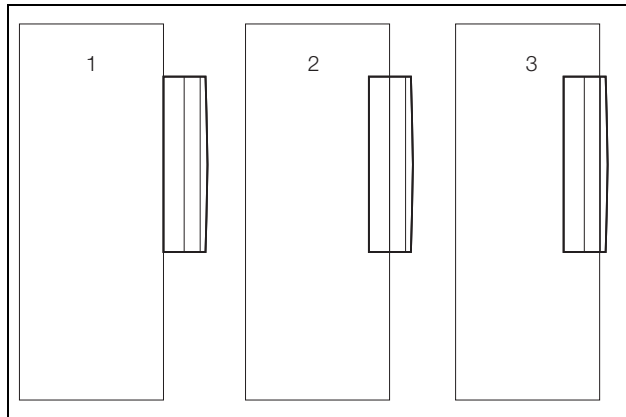

Fig. 5: Installation method

To this end, cut the side panel or door of the enclosure as per the drilling template included with the supply, and drill the relevant holes.



Note:

Units of type SK 3302.xxx can only be either externally mounted or fully internally mounted.

Units of type SK 3332.xxx can only be either externally mounted or partially internally mounted.

For mounting the units SK 3328.xxx, SK 3329.xxx and SK 3332.xxx in the TS side panel or rear panel, we recommend the use of enclosure panel fasteners TS 8800.071 (see Rittal Catalogue).

4.3.1 Cutting out on the enclosure

- Stick the supplied drilling template onto the side panel or door of the enclosure using adhesive tape.

There are dimensioning lines on the drilling template to suit the various installation options for your cooling unit.

- Using the dimension drawings (see Appendix), identify the valid lines and dimensions for your installation type on the drilling template.



Risk of injury!
Carefully deburr all drilled holes and cut-outs to prevent injuries caused by sharp edges.

- Mark, drill and deburr the holes.
- Make the cut-outs including the line width as per the drilling template.
Deburr the cut-outs.

4.3.2 External mounting of the cooling unit

- Cut the supplied sealing tape to the correct length and stick it carefully along the back of the unit so that no gaps are left at the joints.

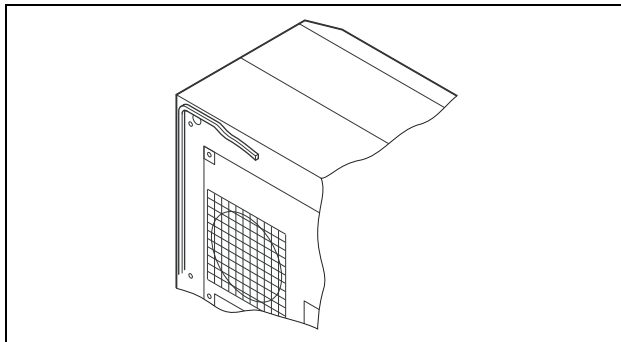

Fig. 6: Attach the sealing tape

- Screw the supplied grub screws into the blind nuts on the rear of the unit.
- Secure the unit using the supplied washers and nuts.

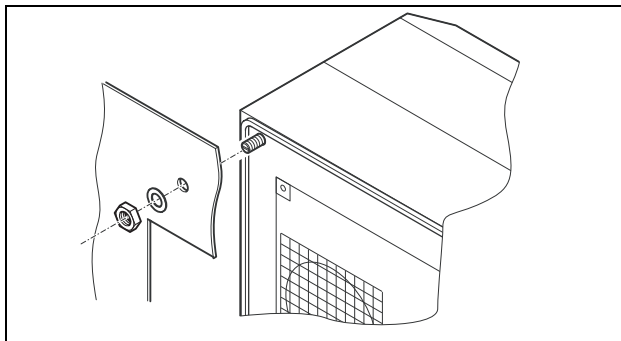

Fig. 7: Secure the cooling unit
(all models except SK 3302.1xx)

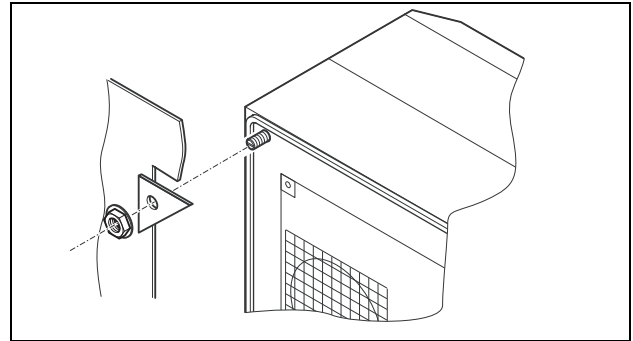

Fig. 8: Secure the cooling unit
(SK 3302.1xx "external mounting" only)

4.3.3 Partial internal mounting of the cooling unit

- Carefully remove the louvred grille and, where applicable, the infill panel, from the enclosure by pulling forwards.
- Carefully disconnect the connector from the rear of the display and gently push it inwards through the cable gland.

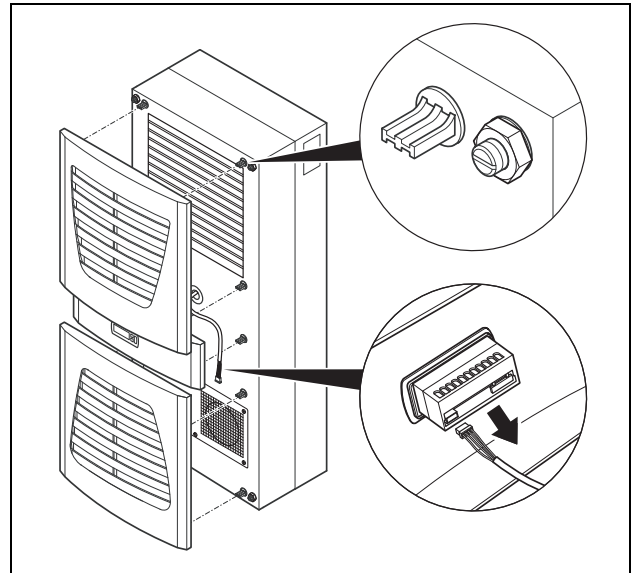

Fig. 9: Remove the louvred grille & disconnect the display



Risk of damage!
Stability of the cooling unit is only guaranteed in its assembled state.
Brace the rear enclosure half to prevent it from falling over before removing the front enclosure half.

- Loosen the four nuts on the front enclosure half and pull the enclosure forwards by approx. 5 cm.
- Loosen the flat-pin connectors of the PE conductor between the two enclosure halves.
- Disconnect the fan connection.
- Remove the front enclosure tray completely.

4 Assembly and connection

EN

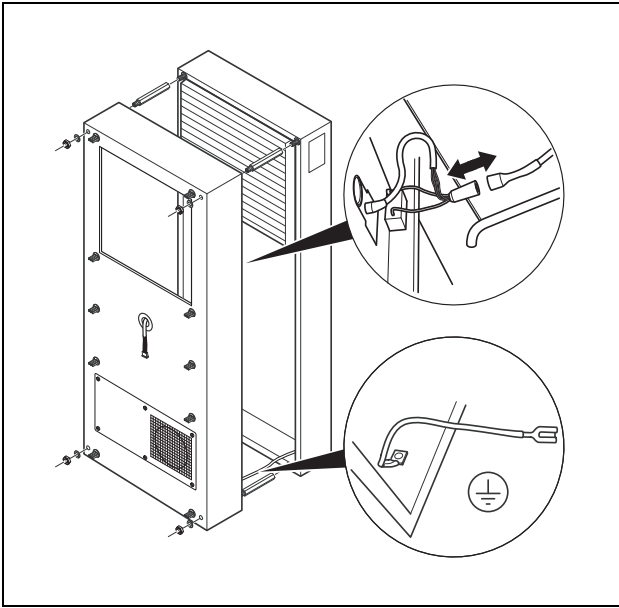

Fig. 10: Remove the cover

- Remove the four spacer bolts.
- Cut the supplied sealing tape to the correct length and stick it carefully along the inside of the rear enclosure half so that no gaps are left at the connection points.

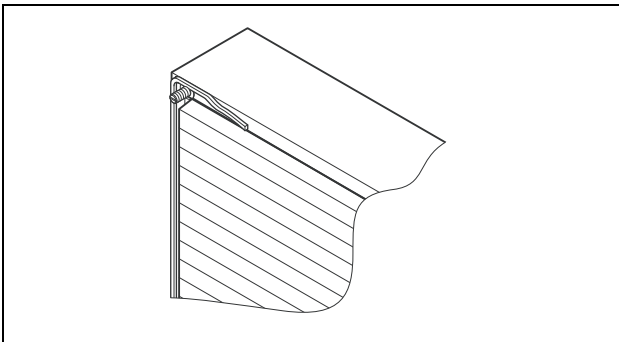

Fig. 11: Attach the sealing tape

- Push the rear enclosure half into the mounting cut-out and secure it with the four spacer bolts.
- Push the display cable through the cable gland of the front enclosure half.

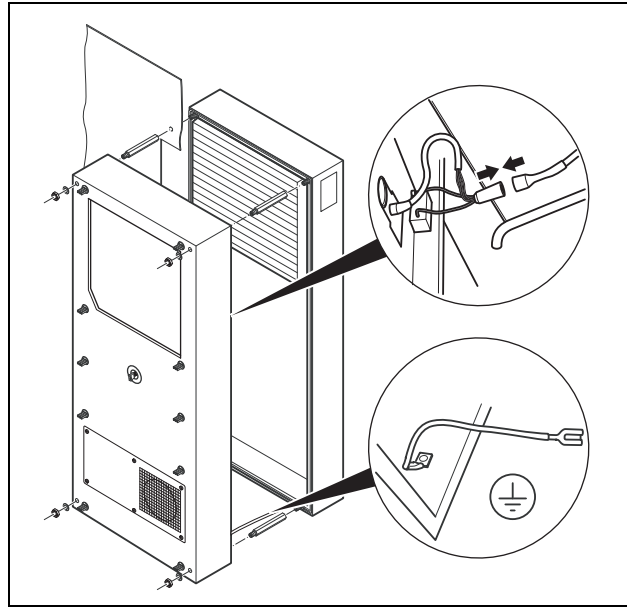

Fig. 12: Secure the cooling unit

- Connect the fan connector and PE conductor.
- Mount the front enclosure tray using the washers and nuts.

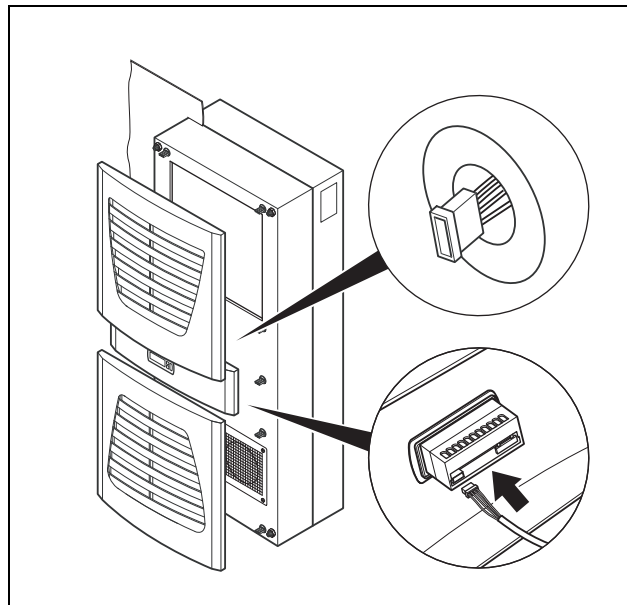

Fig. 13: Connect the display connector

- Carefully connect the display connector.
- Push the louvred grille and, where applicable, the infill panel, onto the enclosure.

4.3.4 Full internal mounting of the cooling unit

- Carefully remove the louvred grille and the infill panel from the enclosure by pulling forwards.
- Carefully disconnect the connector from the rear of the display.

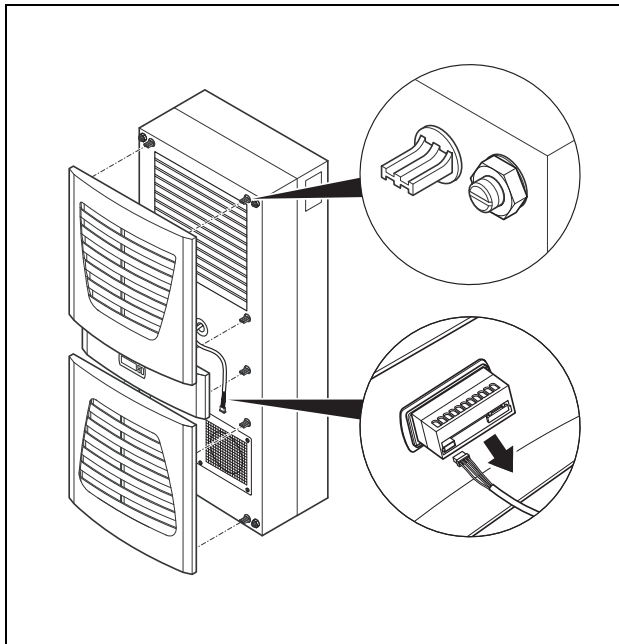

Fig. 14: Remove the louvred grille and disconnect the display

- Cut the supplied sealing tape to the correct length and stick it carefully along the front enclosure half so that no gaps are left at the connection points.

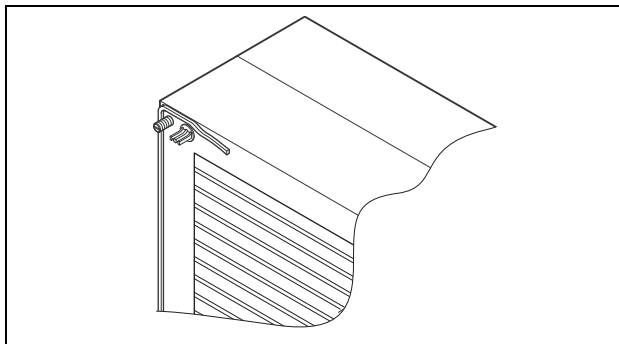

Fig. 15: Attach the sealing tape

- Loosen the four nuts and washers from the front enclosure half.
- Push the unit into the mounting cut-out from the inside of the enclosure, and secure it to the enclosure from the outside using the washers and nuts.

Only for SK 3302.xxx:

- Before installing, remove the four screws as shown.

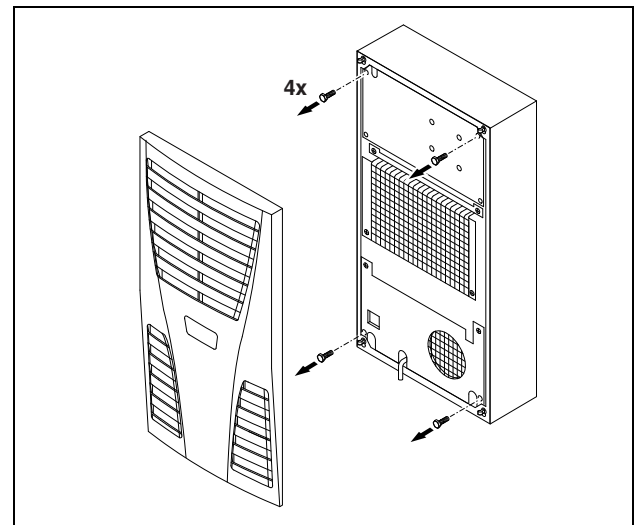

Fig. 16: Only for SK 3302.xxx: Remove the four screws

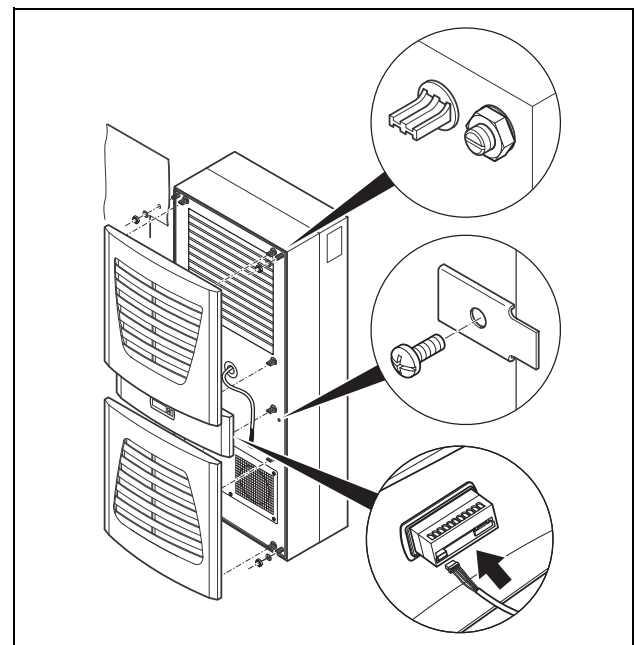

Fig. 17: Secure the cooling unit

- Where necessary, additionally secure the unit using the supplied mounting plates as shown in Fig. 17.
- Carefully connect the display connector.
- Push the louvred grille and, where applicable, the infill panel, onto the enclosure.

4 Assembly and connection

4.4 Connecting the condensate discharge

Unit types SK 3302.xxx, SK 3303.xxx and SK 3361.xxx support the installation of a condensate discharge hose ($\varnothing 1/2''$).

The condensate discharge

- must be laid with a suitable and constant gradient (no siphoning)
- must be laid without kinks
- must not have a reduced cross-section if extended.

The condensate hose is available as an accessory (refer also to Accessories in the Rittal Catalogue).

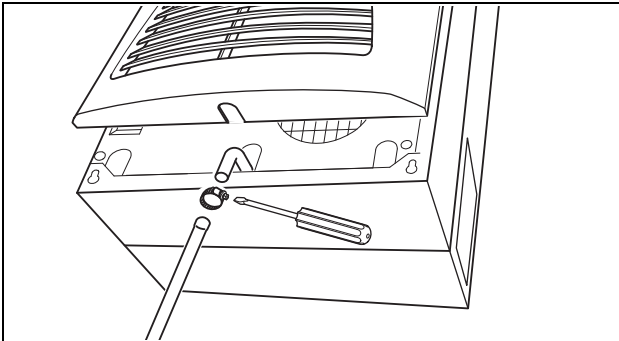

Fig. 18: Connecting the condensate discharge

- Connect a suitable hose to the condensate nozzle and secure using a hose clip.
- Lay the condensate hose into a pay-off or into the external condensate evaporator (refer to accessories in the Rittal Catalogue).

4.5 Notes on electrical installation

When performing the electrical installation, it is important to observe all valid national and regional regulations as well as the provisions of the responsible power supply company. Electrical installation must only be carried out by a qualified electrician who is responsible for compliance with the existing standards and regulations.

4.5.1 Connection data

- The connected voltage and frequency must correspond to the values stated on the rating plate.
- The cooling unit must be connected to the mains via an all-pin isolating device, which ensures at least 3 mm contact opening when switched off.
- No additional temperature control may be connected upstream of the unit at the supply end.
- Install the pre-fuse specified on the rating plate to protect the cable and equipment from short-circuits.
- The mains connection must ensure low-noise potential equalisation.

4.5.2 Overvoltage protection and supply line load

- The unit does not have its own overvoltage protection. Measures must be taken by the operator at the supply end to ensure effective lightning and overvoltage protection. The mains voltage must not exceed a tolerance of $\pm 10\%$.
- In accordance with IEC 61 000-3-11, the unit is intended solely for use at sites with a continuous current-carrying capacity (incoming mains power supply) of more than 100 A per phase and with a supply voltage of 400/230 V. If necessary, the power supply company must be consulted to ensure that the continuous current-carrying capacity at the point of connection to the public grid is sufficient for connection of such a unit.
- The fans and compressors in single- and three-phase units are intrinsically safe (thermal winding protection). The same also applies to the transformer versions of types SK 3304.510, SK 3305.510, SK 3328.510 and SK 3329.510 and to special-voltage units which are likewise equipped with a transformer.
- Install the slow pre-fuse specified on the rating plate (miniature circuit-breaker with appropriate characteristic – e. g. K characteristic – or fuse gG standard type, power circuit-breaker or transformer circuit-breaker) to protect the cable and equipment from short-circuits. Select a suitable circuit-breaker in accordance with the information specified on the rating plate: Set it to the minimum specified value. This will achieve the best short-circuit protection for cables and equipment. Example: Specified setting range 6.3 – 10 A; set to 6.3 A.

4.5.3 Three-phase devices

- The three-phase version of models SK 3304.xxx, SK 3305.xxx, SK 3328.xxx, SK 3329.xxx and SK 3332.xxx must be connected to a TN network with star earthing via a circuit-breaker for plant protection (current setting as per the rating plate). Three-phase units with special voltages must be protected with a circuit-breaker for transformer protection (category AC-3) as per the rating plate.
- Units designed for three phase 400/460 V feature additional monitoring of the rotary field or the absence of a phase. If the rotary field is incorrect or a phase is absent, the unit will not run.

4.5.4 Door limit switch

- Each door limit switch must only be assigned to one cooling unit.
- Several door limit switches may be connected in parallel and operated on one cooling unit.
- The minimum cross-section for the connection cable is 0.3 mm² for a cable length of 2 m.
- The line resistance to the door limit switch must not exceed a maximum of 50 Ω.
- The door limit switch only supports a floating connection; no external voltages.
- The contact of the door limit switch must be closed when the door is open.

The safety extra-low voltage for the door limit switch is provided by the internal power pack: Current approx. 30 mA DC.

- Connect the door limit switch to terminals 1 and 2 of the connector.

4.5.5 Notes on the flicker standard

The flicker limits specified in standard EN 61 000-3-3 or -3-11 are adhered to, provided the supply impedance is less than approx. 1.5 Ω.

Where necessary, the unit operator should measure the connected impedance or consult the responsible power supply company. If there is no way of influencing the supply impedance and sensitive installed components (e.g. BUS) are subjected to interference, a line reactor or starting-current limiting device should be connected upstream of the cooling unit to restrict the startup current of the cooling unit.

4.5.6 Potential equalisation

If, for EMC reasons, the unit is to be integrated into the existing potential equalisation system at the customer, a conductor with a larger nominal cross-section can be connected to the potential equalisation connection point (attachment points) on wall-mounted cooling units.

According to the standard, the PE conductor in the mains connection cable is not classified as an equipotential bonding conductor.

4.6 Carrying out the electrical installation

4.6.1 Bus connection

(only in conjunction with several units with an e-Comfort controller)

When using several cooling units, the serial device interface X2 can be used to connect up to ten cooling units with the bus cable (Model No. SK 3124.100).



Note:

The electrical signals at the X2 interface are of an extra-low voltage (not extra-low safety voltages to EN 60 335-1).

When interconnecting, please note the following:

- De-energise the cooling units to be connected.
- Ensure proper electrical insulation.
- Make sure the cables are not laid in parallel to power lines.
- Make sure that the lines are short.



Caution!

Regarding the last slave unit in the group, do not, under any circumstances, connect the remaining socket of the Y cable SK 3124.100 into interface X3 of the cooling unit!

4.6.2 Connection X3 for serial interface

The interface card (Model No. SK 3124.200) may be connected to X3. This is used to evaluate system messages in a PLC, for remotely setting parameters and monitoring, or for integration into the facility management system.

4.6.3 Installing external transformers

For SK 3361.x40 only.

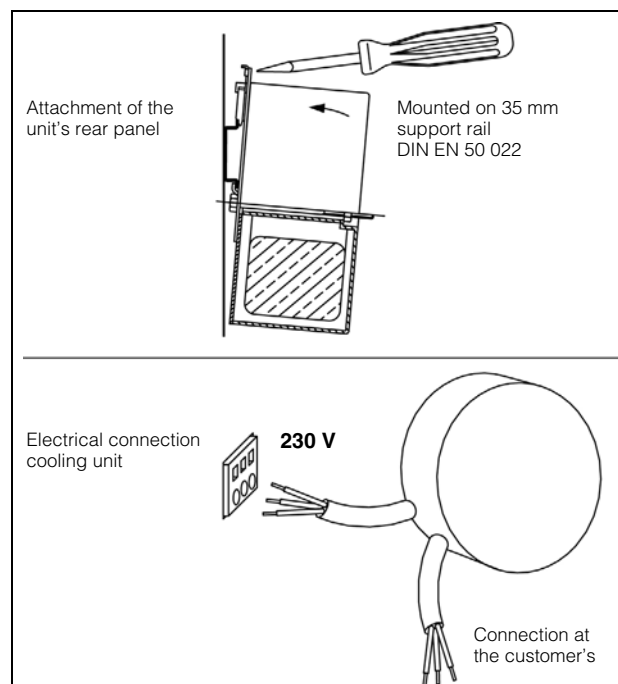

Fig. 19: Installing external transformers (SK 3361.x40 only)

4 Assembly and connection

EN

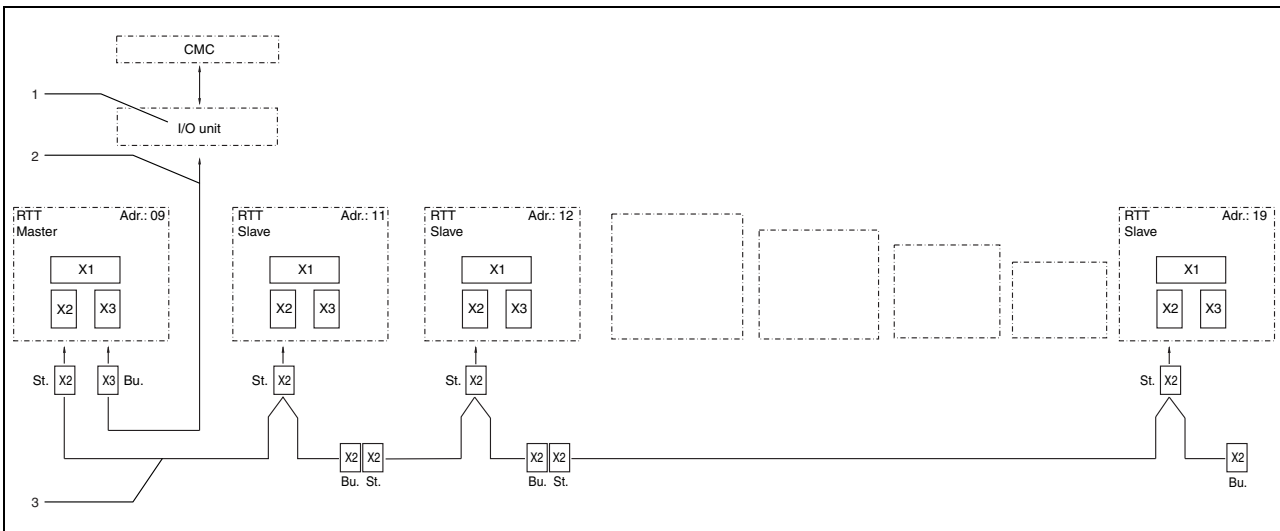

Fig. 20: Connection example: Master-slave operation

Legend

- | | | | |
|-----|--|------|---------------------------------------|
| 1 | Serial interface (Model No. SK 3124.200) | X2 | Master-slave connection Sub-D, 9-pole |
| 2 | Serial interface cable | X3 | Serial interface Sub-D, 9-pole |
| 3 | Master-slave bus cable (Model No. SK 3124.100) | St. | Sub-D connector, 9-pole |
| RTT | Rittal TopTherm cooling units | Bu. | Sub-D jack, 9-pole |
| X1 | Supply connection/door limit switch/alarms | Adr. | Address |

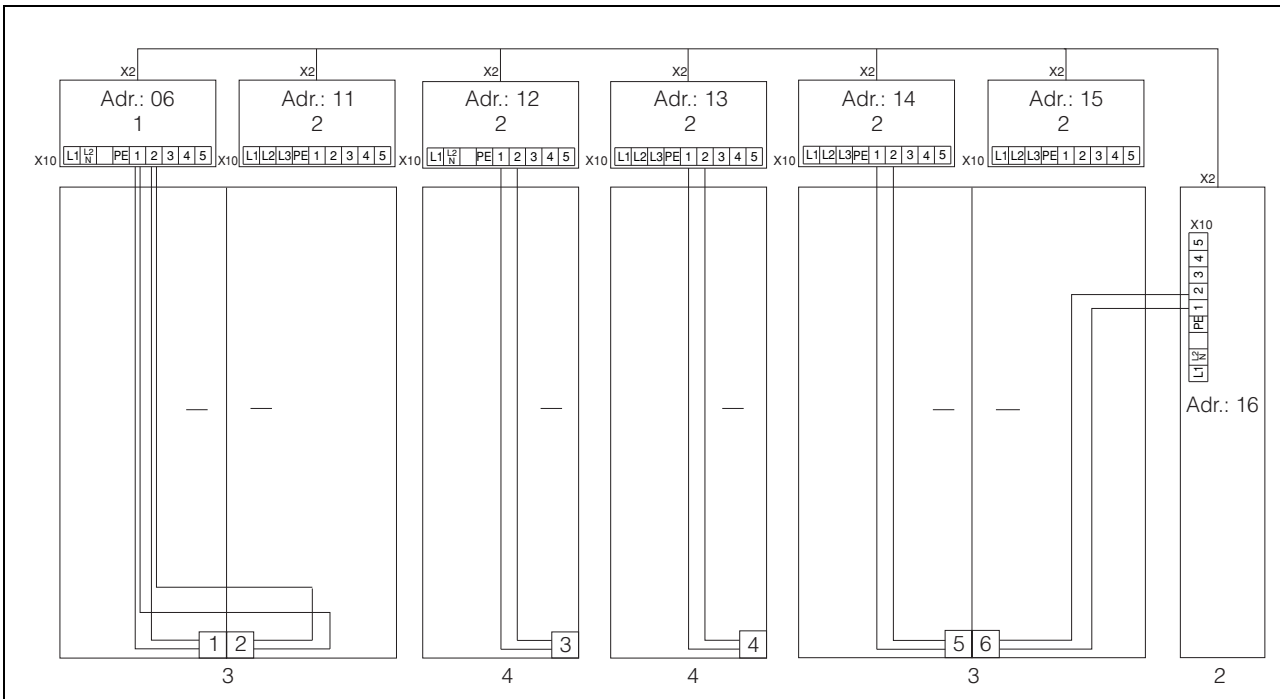

Fig. 21: Connection example: Door limit switch and master-slave operation

Legend

- | | |
|---|---|
| 1 | Master cooling unit |
| 2 | Slave cooling units |
| 3 | 2-door enclosure with two door limit switches |
| 4 | Enclosure with door limit switch |

4.6.4 Installing the power supply

- Complete the electrical installation by following the wiring plan on the rear of the cooling unit (see Fig. 1 on page 5, for key see page 19).
- If you would like the system messages from the cooling unit to be evaluated via the system message relay, you should also connect a suitable low-voltage cable to connection clamps 3 – 5.

SK 3302.100/.110, SK 3302.300/.310

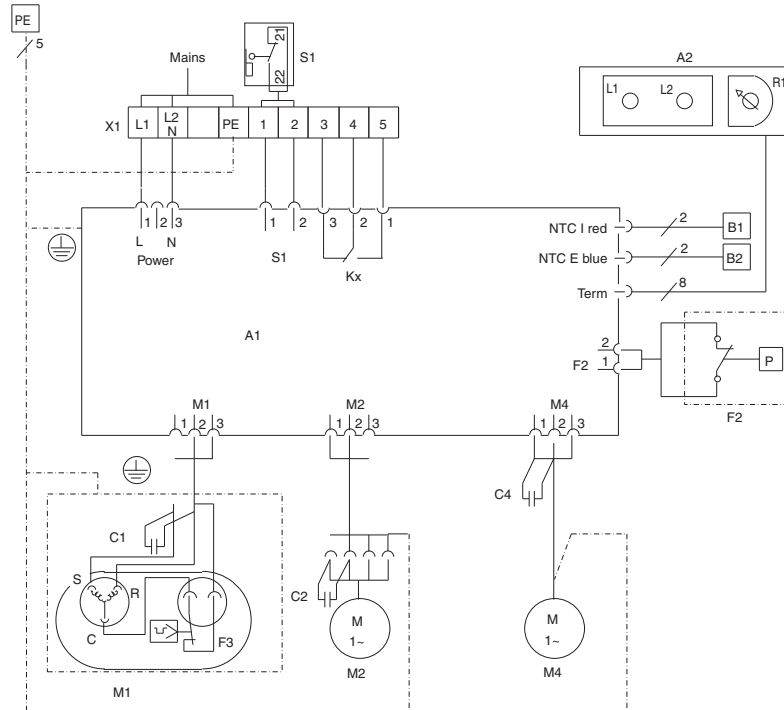

Fig. 22: Electrical wiring plan no. 1

SK 3303.500/.510, SK 3303.600/.610, SK 3361.500/.510, SK 3361.600/.610

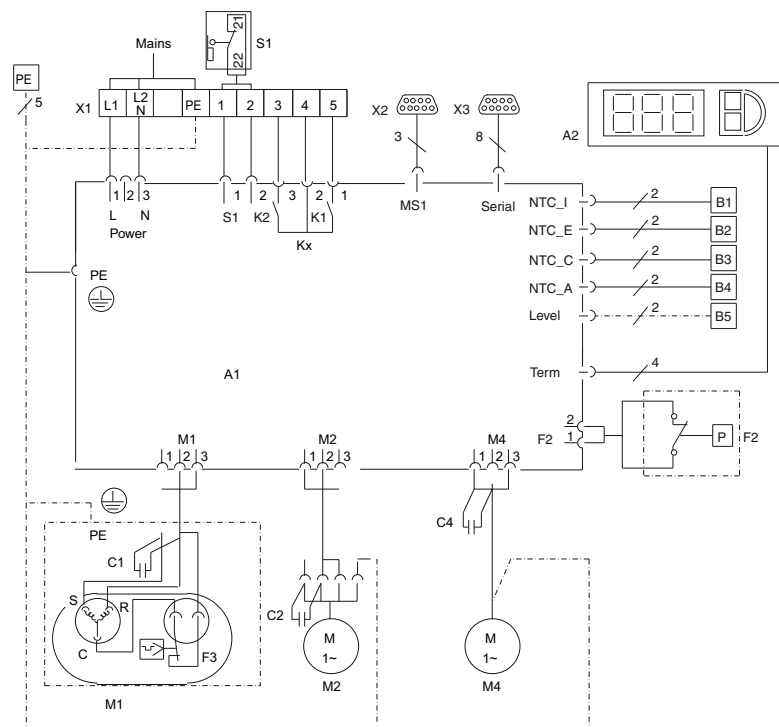

Fig. 23: Electrical wiring plan no. 2

4 Assembly and connection

EN

SK 3305.500/.510/.504/.514/.520, SK 3328.500/.510/.504/.514/.520, SK 3329.500/.510/.504/.514/.520, SK 3305.600/.610, SK 3328.600/.610, SK 3329.600/.610

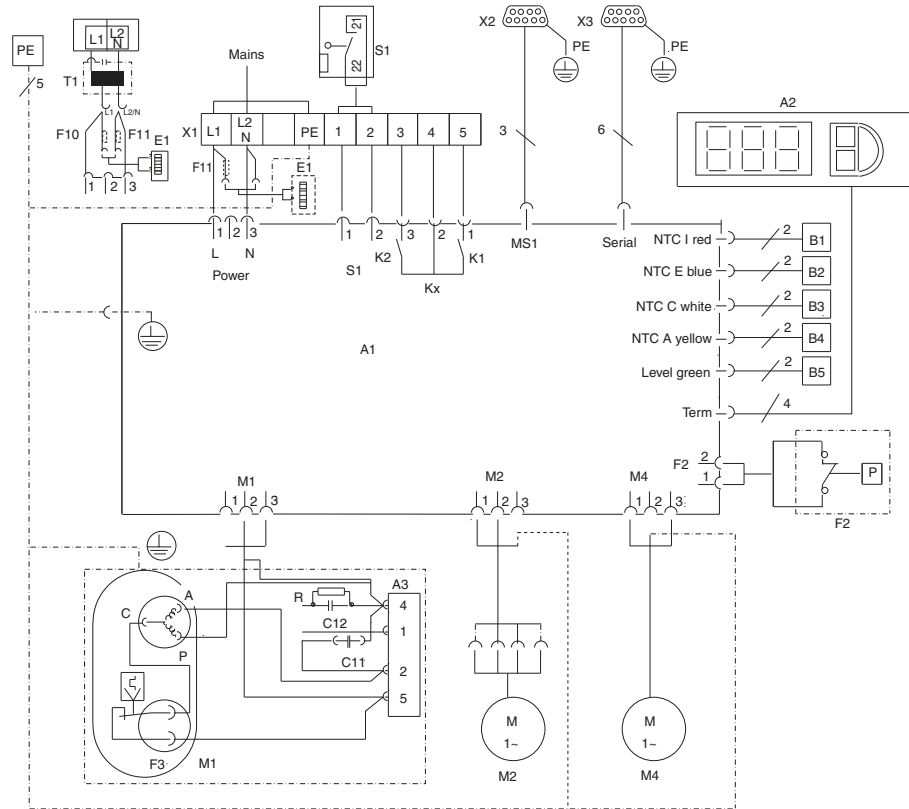

Fig. 26: Electrical wiring plan no. 5

SK 3304.540, SK 3304.544, SK 3305.540, SK 3305.544, SK 3328.540/.544, SK 3329.540/.544, SK 3304.640, SK 3305.640, SK 3328.640, SK 3329.640, SK 3366.540, SK 3366.640

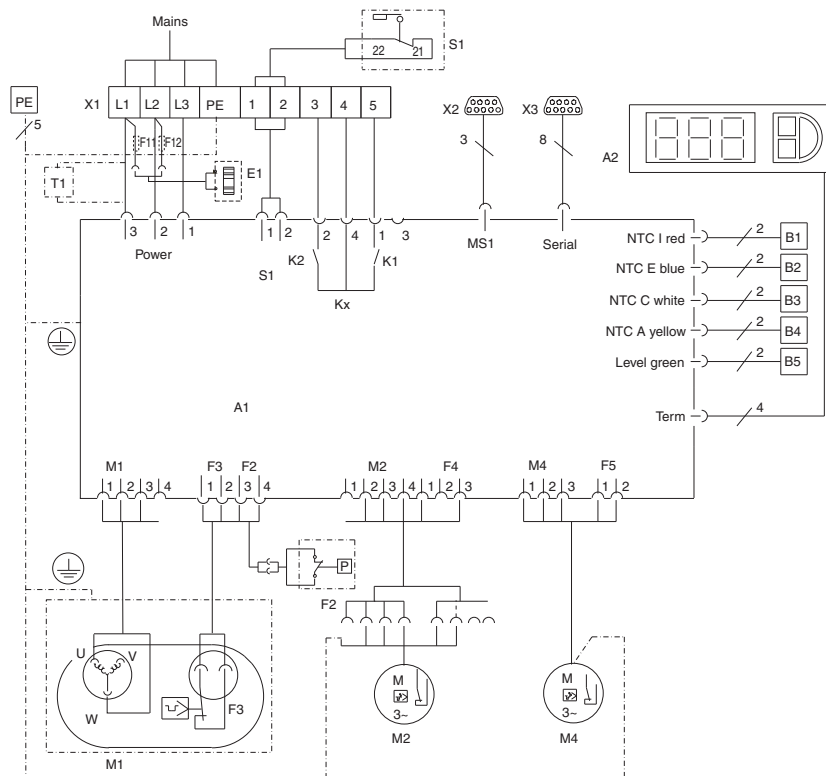

Fig. 27: Electrical wiring plan no. 6

4 Assembly and connection

EN

SK 3366.500/510/600/610

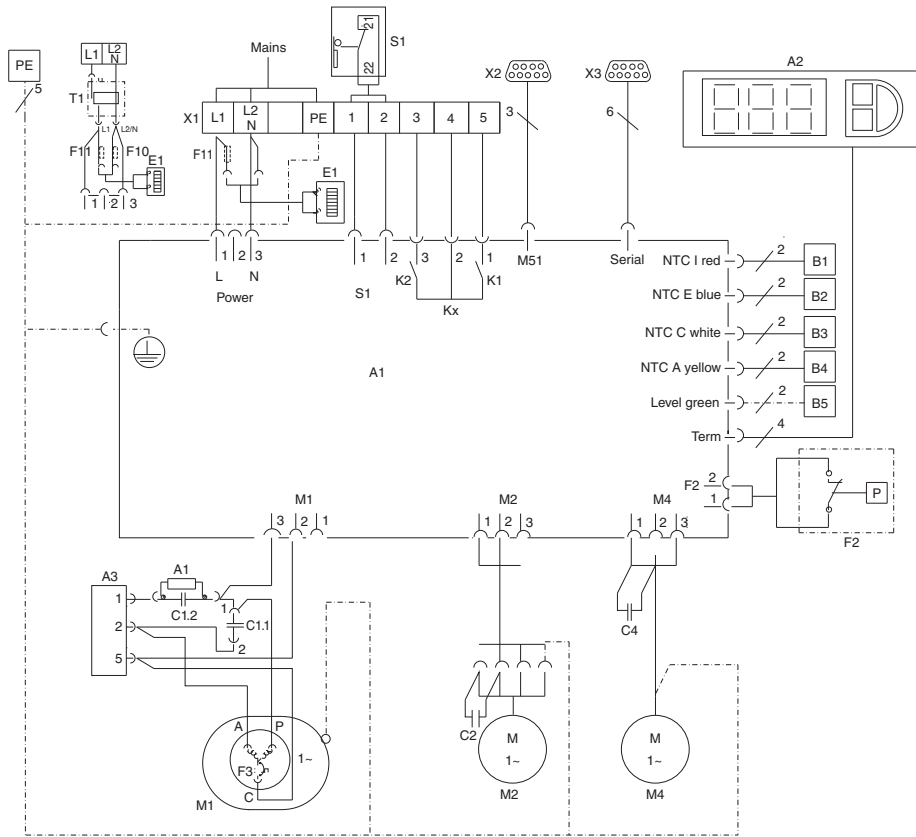

Fig. 28: Electrical wiring plan no. 7

SK 3332.540/640

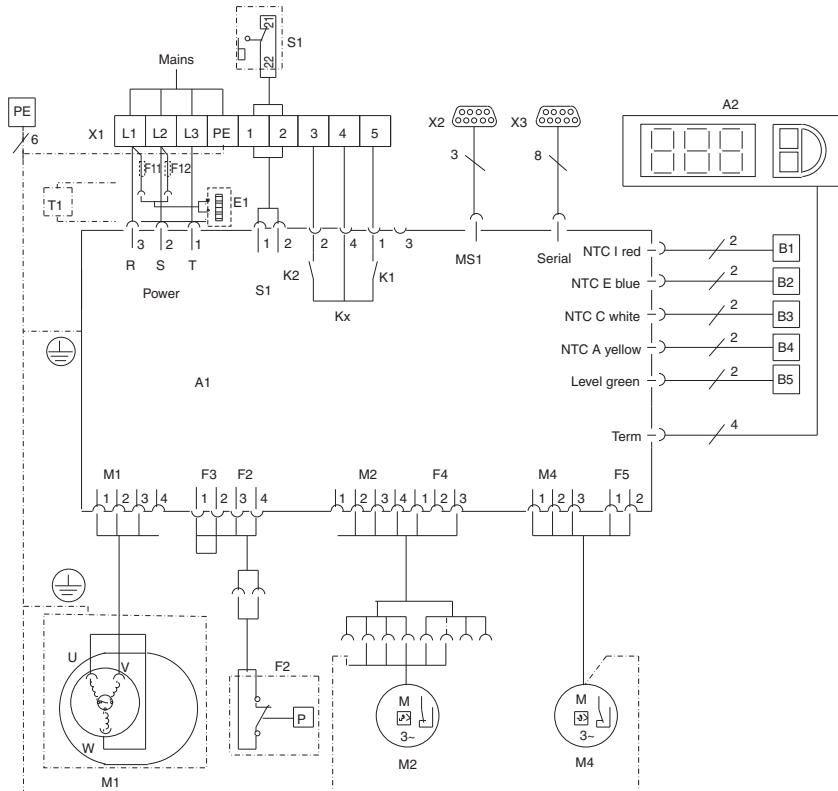

Fig. 29: Electrical wiring plan no. 8

Legend

A1	Power PCB
A2	Display terminal
A3	Starter relay and RC element
B1	Temperature sensor, internal temperature
B2	Icing hazard temperature sensor
B3	Condenser temperature sensor
B4	Ambient temperature sensor
B5	Condensate warning sensor (optional)
C1.2	Start-up capacitor
C1.1, C2, C4	Running capacitors
E1	Condensate evaporator
F2	PSA ^H pressure-operated switch (3302.1x0 has bridge instead of pressostat)
F3	Bimetal contact compressor
F11/F12	Miniature fuses, condensate evaporator
K1	Relay collective fault 1
K2	Relay collective fault 2
L1	LED operational green
L2	LED alarm red
M1	Compressor
M2	Condenser fan
M4	Evaporator fan
R1	Potentiometer for setting the temperature
S1	Door limit switch (without door limit switch: terminal 1, 2 open)
T1	Transformer (optional)
X1	Main terminal strip
X2	Master-slave connection
X3	Optional interface



Note:

For technical data refer to the rating plate.

AC cos f = 1	DC L/R = 20 ms
I max. = 2 A U max. = 250 V	I min. = 100 mA U max. = 200 V U min. = 18 V I max. = 2 A

Tab. 2: Contact data

5 Commissioning

4.7 Finalising assembly

4.7.1 Installing the filter media

The cooling unit condenser is finished all over with a dirt-repelling, easy-to-clean RiNano coating. In many cases, therefore, the use of filter media is unnecessary, particularly in the case of dry dusts.

For dry, coarse dust and lint in the ambient air, we recommend installing an additional PU foam filter mat (available as an accessory) in the cooling unit. For air containing oil condensation, we recommend the use of metal filters (also available as an accessory). When used in textile plants with heavy lint contamination, lint screens should be used (available as an optional extra).

- Pull the louvred air inlet grille from the enclosure.
- Insert the filter mat into the louvred grille as shown in Fig. 30 and push it back onto the enclosure.

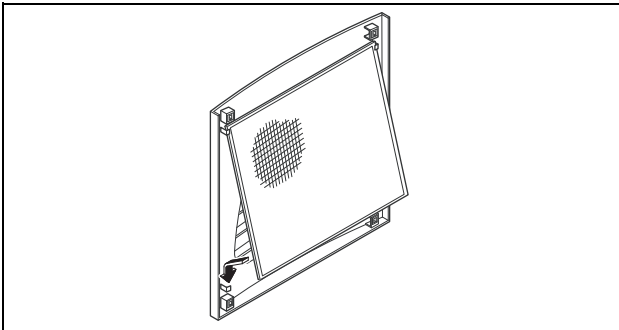

Fig. 30: Installing the filter mat

4.7.2 Fitting the cooling unit

For partial and full internal mounting only.

- Connect the connector to the rear of the display.
- Place the louvred grille onto the unit at the front, and press it down until you hear it snap into place.

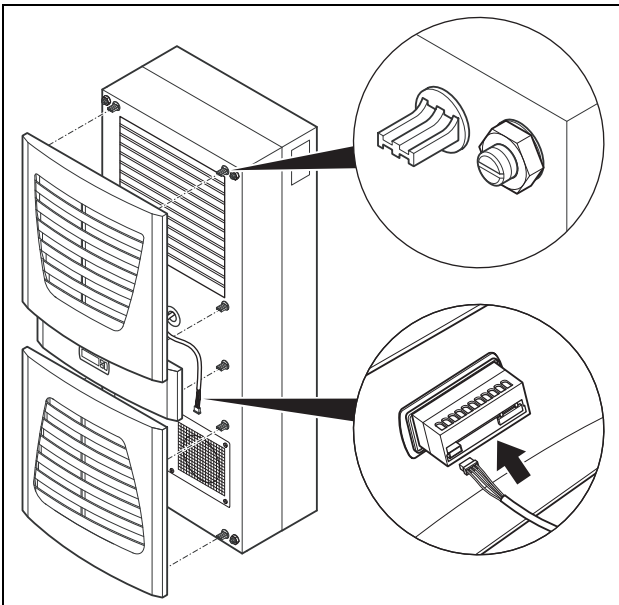

Fig. 31: Connect the display and attach the louvred grille

4.7.3 Setting the filter mat monitor (only with e-Comfort controller)

Function of the filter mat monitor:

Dirt on the filter mat is automatically detected by measuring the temperature difference in the external circuit of the cooling unit (see “6.2.6 Programming overview”, page 26). As the level of filter mat soiling rises, the temperature difference will increase. The nominal value of the temperature difference in the external circuit adapts automatically to the relevant operating points in the performance diagrams. Hence there is no need to readjust the nominal value for different operating points of the cooling unit.

5 Commissioning



Caution! Risk of damage!

The oil must collect in the compressor in order to ensure effective lubrication and cooling.

Do not operate the cooling unit for at least 30 min. after assembling the equipment.

- Once all the assembly and installation work is complete, switch on the power supply to the cooling unit.

The cooling unit starts running:

- With Basic controller: The green operating LED (“line”) is illuminated.
- With e-Comfort controller: The software version of the controller first appears for approx. 2 sec., followed by “ECO” for activated eco-mode. Then the enclosure internal temperature appears in the 7-segment display.

You can now make your individual settings on the unit, e.g. set the temperature or (with e-Comfort controller only) assign the network identifier, etc. (refer to the “Operation” chapter).

6 Operation

You can operate the cooling unit using the controller on the front of the device (Fig. 1, no. 11, page 5). Depending on the model, the unit is equipped with a Basic or an e-Comfort controller.

6.1 Control using the Basic controller

For unit types SK 3302.xxx.

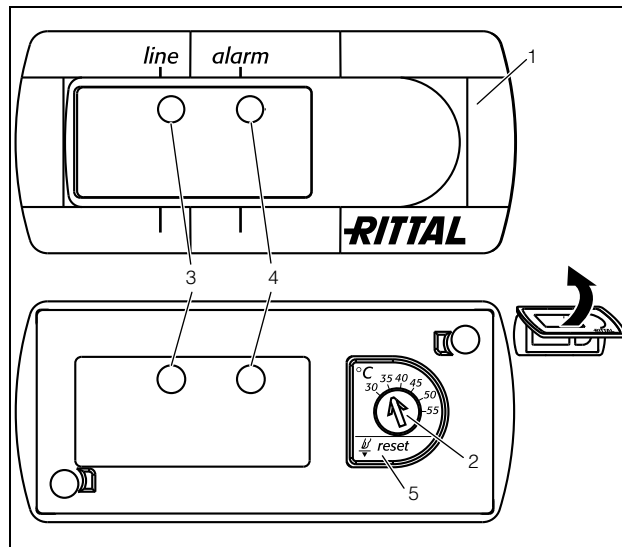

Fig. 32: Basic controller

Legend

- 1 Controller trim panel
- 2 Temperature setting
- 3 LED green ("line")
- 4 LED red ("alarm")
- 5 Reset button

6.1.1 Properties

- Two voltage variants are supported:
 - 115 V
 - 230 V
- Integral start-up delay and door limit switch function
- Protective function to prevent icing
- Monitoring of all motors (compressor, condenser fan, evaporator fan)
- Phase monitoring for three-phase units
- Visualisation of the operating status via LED display:
 - Voltage on, unit operational
 - Door open (only if door limit switch installed)
 - Warning of overtemperature
 - High-pressure-operated switch has switched
- Switching hysteresis: 5 K.

If the cooling unit is oversized and compressor running times are < 1 minute the switching hysteresis is automatically increased to protect the cooling unit.
- Floating system message contact in case of overtemperature
- Temperature setting (setting range 30 – 55°C) via potentiometer
- Test function
- System messages via flashing mode (see "6.1.2 Operating and error system", page 22)

The cooling unit operates automatically i.e. after switching on the power supply, the evaporator fan (see Fig. 2, page 5) will run continuously and permanently circulate the internal enclosure air. The built-in Basic controller ensures automatic normal shut-down operation of the cooling unit by the value of the fixed preset switching difference of 5 K.

6.1.3 Test mode for the Basic controller

The Basic controller is equipped with a test function whereby the cooling unit commences cooling operation independently of the set temperature or door limit switch function.

First you must dismantle the trim panel of the controller.

- Switch off the mains voltage.
- Remove the louvred grille or infill panel in which the controller is installed.
- Release the display lock from behind and pull it forwards slightly.

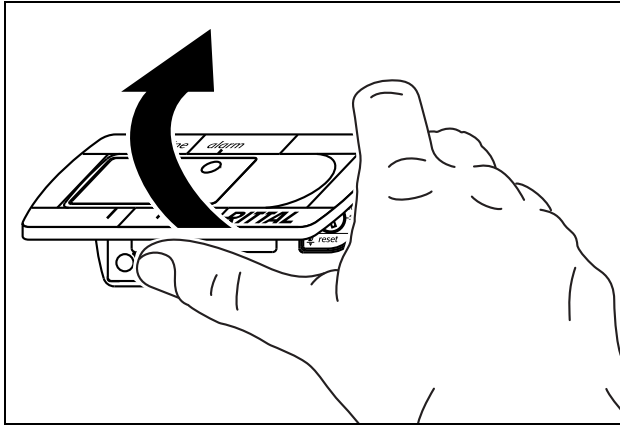

Fig. 33: Loosen the trim panel of the Basic controller

- Carefully raise the trim panel, e.g. using your thumb or a flat screwdriver, and remove it.
- You can now start test mode.
- Rotate the potentiometer to the left-hand stop, then hold the rubberised potentiometer display down while you re-connect the mains voltage.

The cooling unit will commence operation and the green LED will flash (I|_||_||_ . . .). Test mode is completed after approximately 5 minutes. The unit switches off and changes to normal operation.

Key

- I = LED 500 ms on
 _ = LED 500 ms off

In normal operation, the green LED is permanently illuminated.

- Next, rotate the potentiometer back to the required setpoint.

6.1.4 Setting the temperature



Note:

With the Basic controller, the temperature is preset at the factory to +35°C. In order to save energy, do not set the temperature any lower than is actually necessary.

To change the temperature setting:

- Dismantle the trim panel of the controller as described in “6.1.3 Test mode for the Basic controller”, page 23.
- Set the required temperature on the temperature setting device (Fig. 32, page 21).
- Carefully push the trim panel onto the display until you hear it snap into place.
- Push the display back into the infill panel or louvred grille.
- Re-attach the louvred grille or infill panel to the cooling unit.

6.1.5 Resetting the Basic controller

Following a high-pressure alarm in the cooling cycle, and once the cause has been rectified, you will need to manually reset the Basic controller:

- Dismantle the trim panel of the Basic controller as described in “6.1.3 Test mode for the Basic controller”, page 23.
- Press the reset button (Fig. 32, no. 5) for at least 3 sec.

The red LED is extinguished.

- Re-install the Basic controller.

6.2 Control using the e-Comfort controller

For unit types SK 33xx.5xx and SK 33xx.6xx.

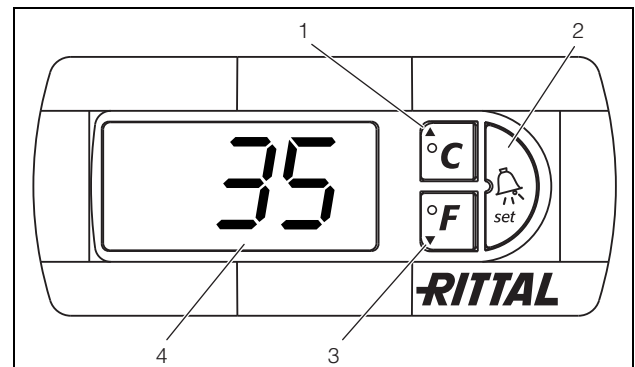

Fig. 34: e-Comfort controller

Legend

- 1 Programming button, also display of the set temperature unit (degrees Celsius)
- 2 Set button
- 3 Programming button, also display of the set temperature unit (degrees Fahrenheit)
- 4 7-segment display

6.2.1 Properties

- Three voltage variants are supported:
 - 115 V
 - 230 V
 - 400/460 V, 3-phase, supports multiple voltages without rewiring
- Integral start-up delay and door limit switch function

6 Operation

- Protective function to prevent icing
- Monitoring of all motors (compressor, condenser fan, evaporator fan)
- Phase monitoring for three-phase units
- Master-slave function with a maximum of ten units. One device functions as a master unit. Once the set temperature is reached by one of the connected slave devices or in the event of the door limit switch function, the affected slave unit will report to the master unit, which will switch all the other cooling units on or off as required.
- Switching hysteresis: Adjustable within the range 2 – 10 K, preset to 5 K.
- Visualisation of the current enclosure internal temperature and all error messages in the 7-segment display.
- Using an interface card (Model No. SK 3124.100), the unit may be incorporated into higher-level remote monitoring systems such as the Rittal Computer Multi Control CMC.

The cooling unit operates automatically i.e. after switching on the power supply, the evaporator fan (see Fig. 2, page 5) starts to run and circulates the internal enclosure air. The compressor and condenser fan are regulated by the e-Comfort controller. The e-Comfort controller has a 7-segment display (Fig. 34, no. 4). After switching on the power supply, the current software version initially appears on this display for approx. 2 seconds, as well as the activated eco-mode. Followed by a preset option (e. g. t10) or the temperature.

In regular operation, the display shows both the temperature (in degrees Celsius or Fahrenheit – users may switch between the two) and any error messages. The current enclosure internal temperature is usually displayed permanently. In the event of an error message, this will alternate with the temperature display. The unit is programmed using buttons 1 – 3 (Fig. 34). The relevant parameters also appear in the display.

6.2.2 Eco-mode

All Rittal TopTherm cooling units with e-Comfort controller from firmware 3.2 have the energy-saving eco-mode, which is activated in the delivered state. The eco-mode is used to save energy in the cooling unit if there is no thermal load, or there is a low thermal load in the enclosure (e. g. standby operation, no production or weekend). During this process the evaporator fan in the internal circuit is switched off as appropriate if the actual enclosure internal temperature drops to 10 K below the setpoint temperature set. To reliably measure the internal temperature also during this process, the fan starts cyclically for 30 sec. (see Fig. 35). If the internal temperature reaches the range 5 K below the setpoint set again, the fan switches back to continuous operation.

If required, the eco-mode can be deactivated via the control display. For this purpose switch the parameter from 1 to 0 in the programming level (see Tab. 4, page 25). The fan then runs continuously.

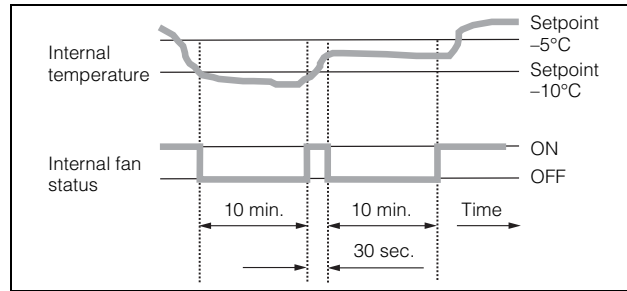

Fig. 35: Diagram of eco-mode

6.2.3 Launching test mode

The e-Comfort controller is equipped with a test function whereby the cooling unit commences cooling operation independently of the set temperature or door limit switch function.

- Simultaneously press buttons 1 and 2 (Fig. 34) for at least 5 sec.

The cooling unit will commence operation.

After approximately 5 minutes, test mode will end.

The unit switches off and changes to normal operation.

6.2.4 General programming information

Using buttons 1, 2 and 3 (Fig. 34) you can change 24 parameters within the preset ranges (min. value – max. value).

Tables 4 and 5 show the parameters which can be altered. Fig. 36 of page 26 shows which buttons must be pressed.



Note on switching hysteresis:

With a low hysteresis and short switching cycles, there is a risk that cooling may not be adequate or that only partial sections of the enclosure are cooled. If the cooling unit is oversized and compressor running times are < 1 minute the switching hysteresis is automatically increased to protect the cooling unit.

Note on temperature settings:

With the e-Comfort controller, the temperature is preset at the factory to +35°C. In order to save energy, and due to the risk of increased condensation, do not set the temperature lower than that actually necessary.

Note on useful cooling output:

Interactive performance diagrams for calculating the useful cooling output may be found at www.rittal.com.

In principle, the programming is identical for all editable parameters.

To enter programming mode:

- Press button 2 (“Set”) for approx. 5 sec.

The controller is now in programming mode. While in programming mode, if you do not press any buttons for approx. 30 sec., the display will first flash, then the controller will switch back to normal display mode. The “Esc” display indicates that any made changes have not been saved.

- Press the programming buttons ▲ (°C) or ▼ (°F) to switch back and forth between the editable parameters (see tables 4 and 5).
- Press button 2 (“Set”) to select the displayed parameter for editing.

The current value of this parameter is displayed.

- Press one of the programming buttons ▲ (°C) or ▼ (°F).

The “Cod” display will appear. In order to be able to change a value, you must enter the authorisation code “22”.

- Keep the programming button ▲ (°C) held down until “22” appears.

- Press button 2 (“Set”) to confirm the code.

You can now alter the parameter within the preset limits.

- Press one of the programming buttons ▲ (°C) or ▼ (°F) until the required value appears.

- Press button 2 (“Set”) to confirm the change.

You can now alter other parameters in the same way. There is no need to re-enter the authorisation code “22”.

- To exit programming mode, press button 2 (“Set”) again for approximately 5 sec.

“Acc” will appear in the display to indicate that the changes have been saved. The display will then switch back to regular operation (enclosure internal temperature).

You can also program the e-Comfort controller using a diagnosis software package (Model No. SK 3159.100), the supply of which also includes a connection cable to the PC. The cable connector on the rear of the e-Comfort controller display serves as an interface.

6.2.5 Editable parameters

See also Fig. 36 on page 26.

Progr. level	Display screen	Parameter	Min. value	Max. value	Factory setting	Description
1	St	Internal enclosure temperature setpoint T_i	20	55	35	The setting of the enclosure internal temperature is preset at the factory to 35°C and may be altered within a range of 20 – 55°C.
2	Fi	Filter mat monitoring	10	60	99 (= off)	To activate filter mat monitoring, set the display to at least 10 K above the temperature differential displayed in programming mode “Fi”. Filter mat monitoring is preset to “deactivated” in the factory (99 = off).
3	Ad	Master-slave identifier	0	19	0	See “6.2.8 Setting the master-slave identifier”, page 28.
4	CF	Temperature conversion °C/°F	0	1	0	The temperature display can be switched from °C (0) to °F (1). The corresponding LED displays the current unit of temperature.
5	H1	Setting for switching difference (hysteresis)	2	10	5	The cooling unit is preset in the factory to a switching hysteresis of 5 K. This parameter should only be changed in consultation with us. Please contact us for advice.
6	H2	Differential for error message A2	3	15	5	If the internal enclosure temperature exceeds the set value by more than 5 K, then error message A2 (enclosure internal temperature too high) appears on the display terminal. If necessary, the differential may be altered here within the range of 3 – 15 K.
26	ECO	Eco-mode operation	0	1	1	Eco-mode OFF: 0 / Eco-mode ON: 1

Tab. 4: Editable parameters

6 Operation

6.2.6 Programming overview

EN

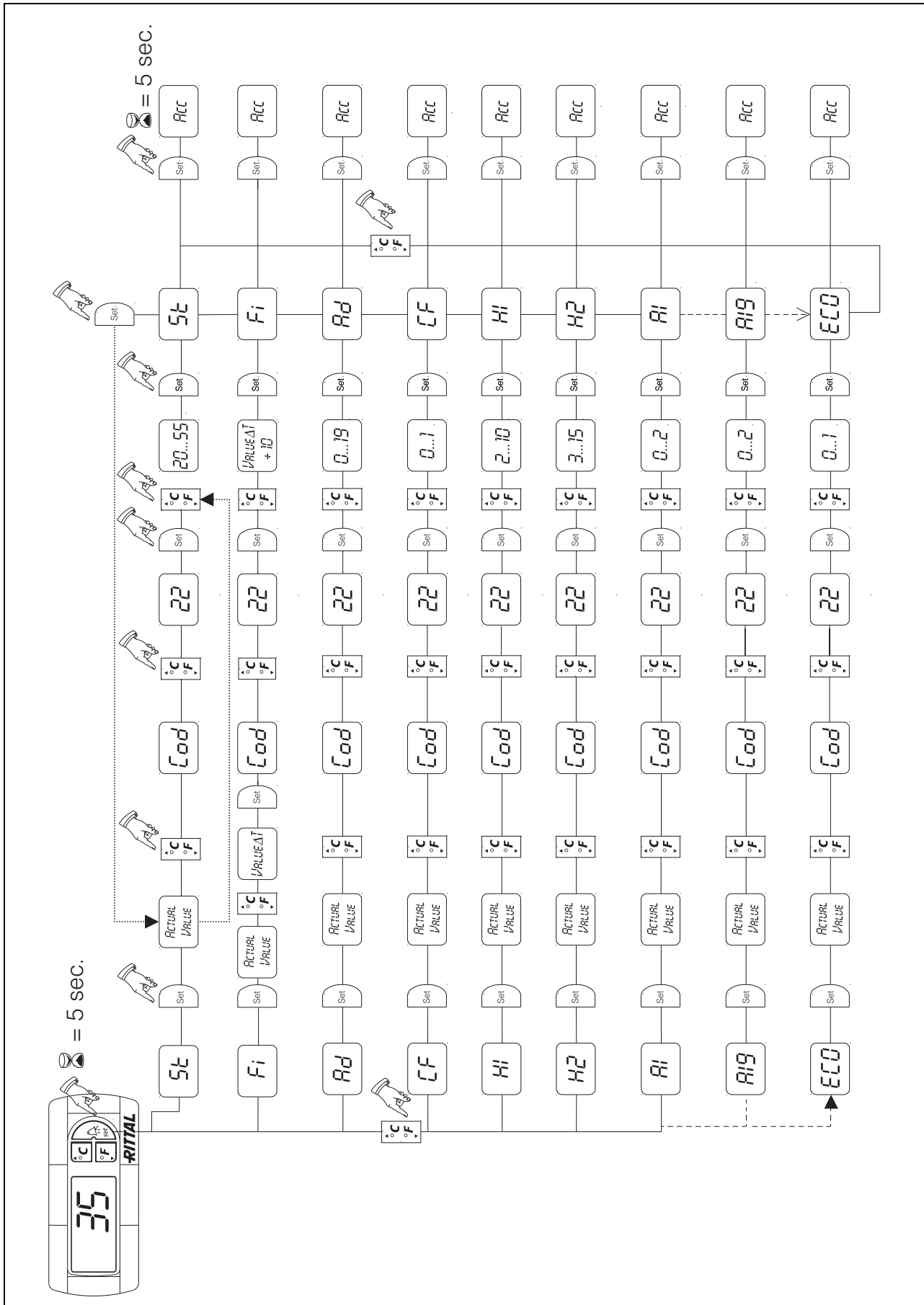

Fig. 36: Programming overview

6.2.7 Defining system messages for evaluation

System messages are shown on the display screen of the e-Comfort controller via the displays A1 to A20 and E0.

A more detailed explanation of the system messages may be found in section “6.2.9 Evaluating system messages”, page 28.

See also Fig. 36 on page 26.

Progr. level	Display screen	Min. value	Max. value	Factory setting	Type or location of fault
7	A1	0	2	0	Enclosure door open
8	A2	0	2	0	Internal temperature of enclosure too high
9	A3	0	2	0	Filter monitoring
10	A4	0	2	0	Ambient temperature too high/too low
11	A5	0	2	0	Icing hazard
12	A6	0	2	1	PSA ^H pressure-operated switch
13	A7	0	2	2	Evaporator coil
14	A8	0	2	1	Condensate warning
15	A9	0	2	1	Condenser fan blocked or defective
16	A10	0	2	1	Evaporator fan blocked or defective
17	A11	0	2	2	Compressor
18	A12	0	2	1	Condenser
19	A13	0	2	1	Ambient temperature sensor
20	A14	0	2	1	Icing temperature sensor
21	A15	0	2	1	Condensate warning temperature sensor
22	A16	0	2	1	Internal temperature sensor
23	A17	0	2	1	Phase monitoring
24	A18	0	2	0	EPROM
25	A19	0	2	0	LAN/Master-Slave

Tab. 5: System messages which may be evaluated via relays

The system messages A1 – A19 may additionally be evaluated via two floating system message relays. In this way, one of the two system message relays may be allocated to each system message.

System alarm relay with normally open contact: see connection diagrams under “4.6.4 Installing the power supply”, page 14:

- Terminal 3: NO (normally open, relay 2)
- Terminal 4: C (connection of the supply voltage to the system message relay)
- Terminal 5: NO (normally open, relay 1)

The definition NO refers to the de-energised state. As soon as power is applied to the cooling unit, both system message relays (relay 1 and 2) energise.

This is the normal operating state of the cooling unit. As soon as a system message occurs or the power supply is interrupted, the corresponding relay will drop out and open the contact.

Program system messages with the value

- 0: System message is not sent to the system message relay, but merely appears in the display
- 1: System message is evaluated by relay 1
- 2: System message is evaluated by relay 2

6 Operation

EN

6.2.8 Setting the master-slave identifier

When several cooling units are connected together (maximum ten), one of the cooling units must be defined as the “master” and the others as “slaves”. For this purpose, assign a corresponding identifier (address) to each cooling unit which will enable the cooling unit to be identified in the network.

If one of the slave units reaches the set temperature or if the door limit switch function is activated, the affected slave unit will report to the master unit, which then deactivates all the other cooling units.



Notes:

- Only one unit may be configured as master, and its identifier must match the number of slave units connected.
- The slave units must have different identifiers.
- The identifiers must be numbered in ascending order without any gaps.

On the **master cooling unit** (00 = factory setting), set the number of slave units present in the network:

- 01: Master with 1 slave cooling unit
- 02: Master with 2 slave cooling units
- 03: Master with 3 slave cooling units
- 04: Master with 4 slave cooling units
- 05: Master with 5 slave cooling units
- 06: Master with 6 slave cooling units
- 07: Master with 7 slave cooling units
- 08: Master with 8 slave cooling units
- 09: Master with 9 slave cooling units

On the **slave cooling unit** (00 = factory setting), set its own address:

- 11: Slave cooling unit no. 1
- 12: Slave cooling unit no. 2
- 13: Slave cooling unit no. 3
- 14: Slave cooling unit no. 4
- 15: Slave cooling unit no. 5
- 16: Slave cooling unit no. 6
- 17: Slave cooling unit no. 7
- 18: Slave cooling unit no. 8
- 19: Slave cooling unit no. 9

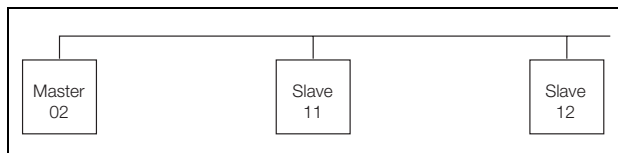

Fig. 37: Master-slave connection (example)

For further connection examples, see “4.6.1 Bus connection (only in conjunction with several units with an e-Comfort controller)”, page 13.

For details of how to set the identifier, see “6.2.5 Editable parameters”, page 25 or “6.2.6 Programming overview”, page 26, parameter “Ad”.

6.2.9 Evaluating system messages

In the e-Comfort controller, system messages are indicated by a number in the display.

Following the appearance of messages A03, A06 and A07 and after rectifying their cause, you will need to reset the e-Comfort controller (see “6.2.10 Resetting the e-Comfort controller”, page 30).

Display screen	System message	Possible cause	Measures to rectify the fault
A01	Enclosure door open	Door open or door limit switch incorrectly positioned	Close door, position door limit switch correctly, check connection if necessary
A02	Internal temperature of enclosure too high	Cooling capacity inadequate/unit undersized. Error as a consequence of messages A03 to A17.	Check cooling capacity
A03	Filter monitoring	Filter mat soiled	Clean or replace; reset the e-Comfort controller
A04	Ambient temperature too high/too low	Ambient temperature outside of admissible operating range (+10°C to +60°C)	Raise or lower the ambient temperature (e.g. heat or ventilate the room)
A05	Icing hazard	Operational display in case of icing hazard. Evaporator coil fan may be mechanically blocked, defective, or cold air outlet obstructed.	Set the enclosure interior temperature to a higher value. Check the evaporator fan; release or exchange if necessary.
A06	PSA ^H pressure-operated switch	Ambient temperature too high	Lower the ambient temperature; reset the e-Comfort controller
		Condenser soiled	Clean the condenser; reset the e-Comfort controller
		Filter mat soiled	Clean or replace; reset the e-Comfort controller
		Condenser fan defective	Replace; reset the e-Comfort controller
		E-valve defective	Have the sensor repaired by a refrigeration engineer; reset the e-Comfort controller
A07	Evaporator coil	Lack of coolant; sensor in front of or behind condenser defective.	Have the sensor repaired by a refrigeration engineer; reset the e-Comfort controller
		PSA ^H pressure-operated switch defective	Have the switch replaced by a refrigeration engineer; reset the e-Comfort controller
A08	Condensate warning	Condensate discharge kinked or blocked	Check condensate discharge; repair any kinks or blockages in the hose as necessary
		Only in units with optional condensate evaporation	Check the evaporation unit, exchange if necessary
A09	Condenser fan	Blocked or defective	Clear the blockage; replace if necessary
A10	Evaporator fan	Blocked or defective	Clear the blockage; replace if necessary
A11	Compressor	Compressor overloaded (internal winding protection)	No action required; unit switches back on automatically.
		Defective (check by measuring the winding resistance)	Exchange by refrigeration engineer
A12	Condenser temperature sensor	Open or short-circuit	Replace
A13	Ambient temperature sensor	Open or short-circuit	Replace
A14	Icing temperature sensor	Open or short-circuit	Replace
A15	Condensate warning temperature sensor	Open or short-circuit	Replace
A16	Internal temperature sensor	Open or short-circuit	Replace
A17	Phase monitoring	For three-phase devices only: Incorrect rotary field/phase absent	Exchange two phases
A18	EPROM error	New board obstructed	Software update needed (only following board installation with more recent software): Enter the programming level with Code 22; press button 1 and confirm with "Set" until "Acc" appears. Next, disconnect the unit from the mains and reconnect.
A19	LAN/Master-Slave	Master and slave not connected	Check setting and/or cable
A20	Voltage drop	Error display not shown	Event is stored in the log file
E0	Display message	Connection problem between the display and the controller board	Reset: Switch power supply off, then switch on again after approx. 2 sec.
		Cable defective; connection loose	Exchange the boards
OL	Overload	Ambient parameters or heat loss outside of the applicable limits	
b07	Cooling circuit leak	Sensor B3 and B4 mixed up	Correct sensor position
rSt	Reset	Manual device reset required, see "6.2.10 Resetting the e-Comfort controller", page 30.	

Tab. 6: Troubleshooting with the e-Comfort controller

7 Inspection and maintenance

EN

6.2.10 Resetting the e-Comfort controller

After the occurrence of faults A03, A06 and A07, you will need to reset the e-Comfort controller.

- Press buttons 1 (▲) and 3 (▼) (Fig. 34) simultaneously for 5 sec.

The system messages will disappear and the temperature display will be shown.

7 Inspection and maintenance



Risk of electric shock!

The unit is live.

Switch off the power supply before opening, and take suitable precautions against it being accidentally switched back on.

7.1 General

The cooling circuit is designed in the form of a maintenance-free, hermetically sealed system. The cooling unit is filled with the required quantity of refrigerant at the factory, checked for leaks, and subjected to a functional test run.

The installed maintenance-free fans are mounted on ball bearings, protected against moisture and dust, and fitted with a temperature monitor. The life expectancy is at least 30,000 operating hours. The cooling unit is thus largely maintenance-free. All that may be required from time to time is to clean the components of the external air circuit using a vacuum cleaner or compressed air if they become visibly dirty. Any stubborn, oily stains may be removed using a non-flammable detergent, such as degreaser.

Maintenance interval: 2000 operating hours. Depending on the level of contamination in the ambient air, the maintenance interval may be reduced to suit the air pollution intensity.



Caution!

Risk of fire!

Never use flammable liquids for cleaning.

Sequence of maintenance measures:

- Check the level of dirt.
- Filter soiling? Replace the filter if necessary.
- Cooling membranes soiled? Clean if necessary.
- Activate test mode; cooling function OK?
- Check noise generation of compressor and fans.

7.1.1 Compressed air cleaning SK 3304.xxx, SK 3305.xxx



Fig. 38: Disconnect the power cord



Fig. 39: Remove the upper louvred grille

7 Inspection and maintenance

EN



Fig. 40: Remove the lower louvred grille



Fig. 42: Disconnect the connector from the display (1)



Fig. 41: Remove the infill panel

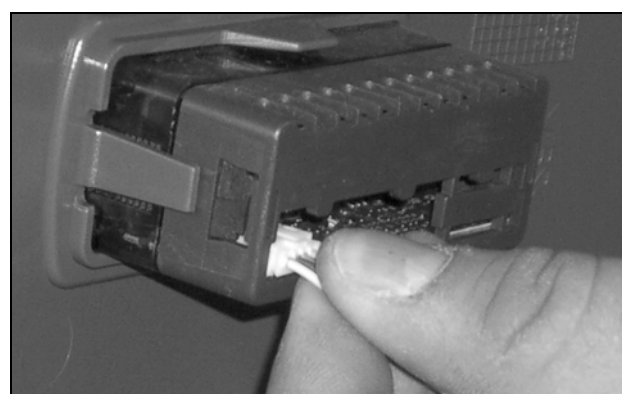

Fig. 43: Disconnect the connector from the display (2)

7 Inspection and maintenance

EN



Fig. 44: Cooling unit without grille

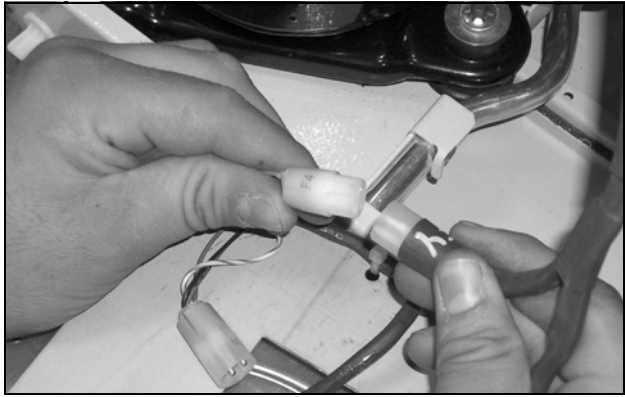

Fig. 47: Disconnect the fan connectors

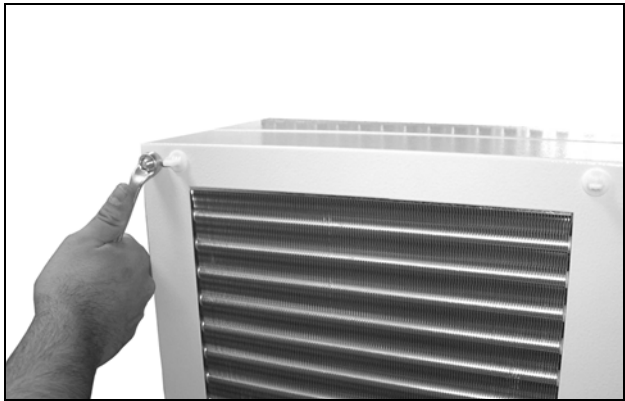

Fig. 48: Dismantle cover (loosen 4 nuts)

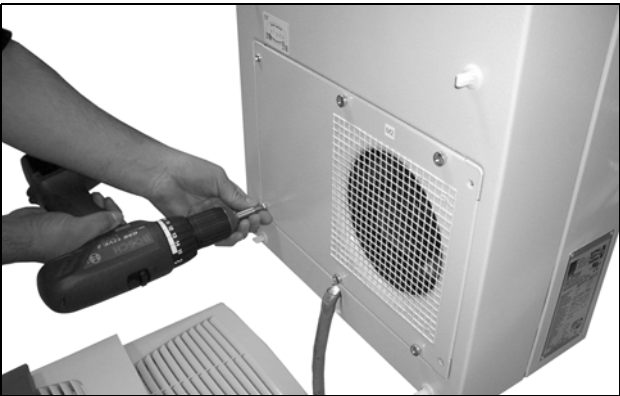

Fig. 45: Remove the external circuit fan (loosen the four screws)

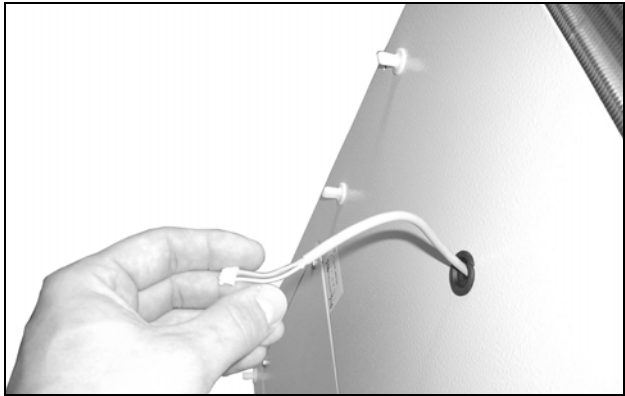

Fig. 49: Push back the display cable

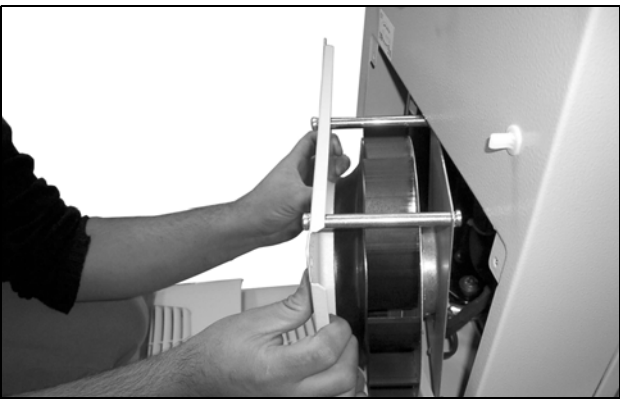

Fig. 46: Remove the fan

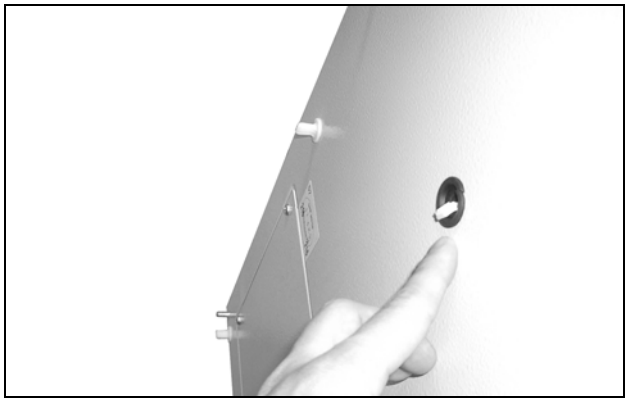

Fig. 50: Push the display cable through the cable gland

7 Inspection and maintenance

EN



Fig. 51: Remove the cover (1)

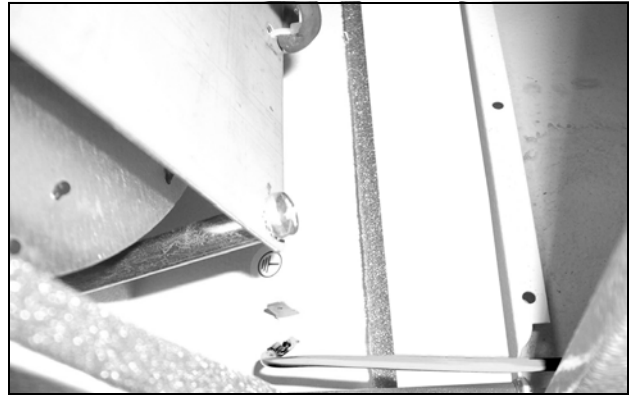

Fig. 53: Loosen the earthing cable between the cover and the chassis (1)



Fig. 54: Loosen the earthing cable between the cover and the chassis (2)



Fig. 52: Remove the cover (2)



Fig. 55: Clean out the heat exchanger coil and compressor chamber using compressed air (1)

7 Inspection and maintenance

EN



Fig. 56: Clean out the heat exchanger coil and compressor chamber using compressed air (2)



Fig. 58: Remove the upper louvred grille (1)

7.1.2 Compressed air cleaning SK 3328.xxx, SK 3329.xxx, SK 3332.xxx



Fig. 57: Disconnect the power cord



Fig. 59: Remove the upper louvred grille (2)

7 Inspection and maintenance

EN



Fig. 60: Remove the upper louvred grille (3)



Fig. 62: Remove the lower louvred grille (2)



Fig. 61: Remove the lower louvred grille (1)



Fig. 63: Remove the infill panel

7 Inspection and maintenance

EN



Fig. 64: Disconnect the display cable



Fig. 68: Remove the external circuit fan

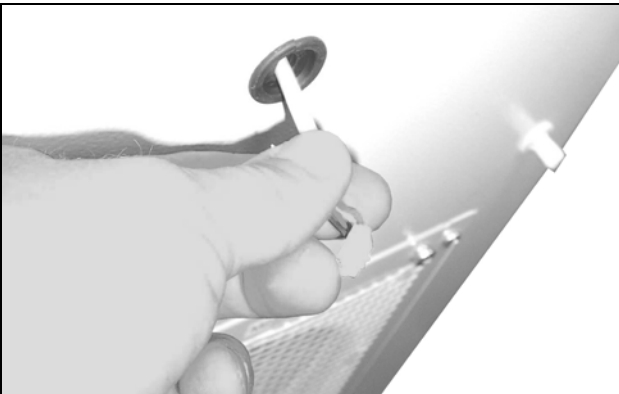

Fig. 65: Push back the display cable and press it through the cable gland (1)



Fig. 69: Disconnect the fan connectors (1)

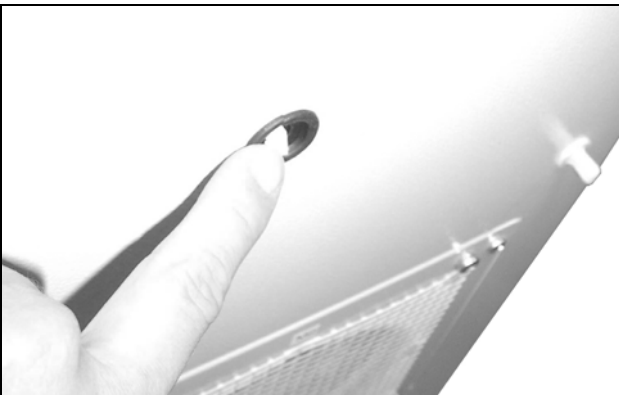

Fig. 66: Push back the display cable and press it through the cable gland (2)

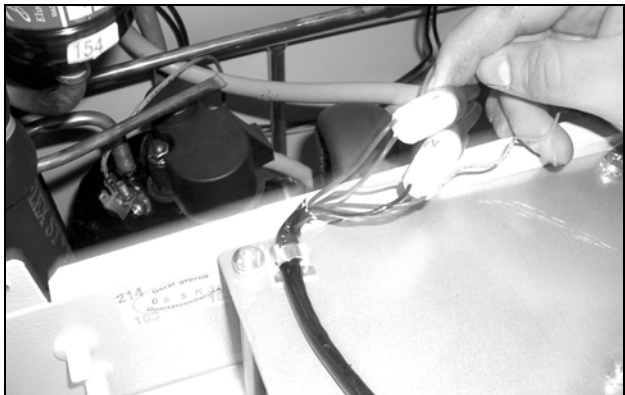

Fig. 70: Disconnect the fan connectors (2)



Fig. 67: Loosen the four screws of the external circuit fan

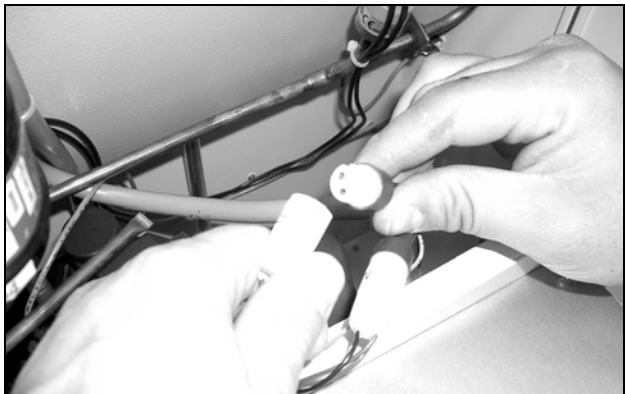

Fig. 71: Disconnect the fan connectors (3)

7 Inspection and maintenance

EN

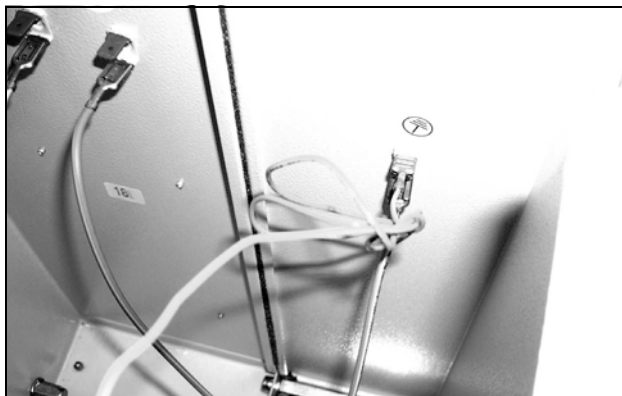

Fig. 72: Disconnect the fan earthing cable (1)



Fig. 73: Disconnect the fan earthing cable (2)



Fig. 75: Remove the cover



Fig. 74: Loosen the four nuts of the cover



Fig. 76: Disconnect the earthing cable (1)

7 Inspection and maintenance

EN



Fig. 77: Disconnect the earthing cable (2)



Fig. 79: Clean out the heat exchanger coil and compressor chamber using compressed air (2)

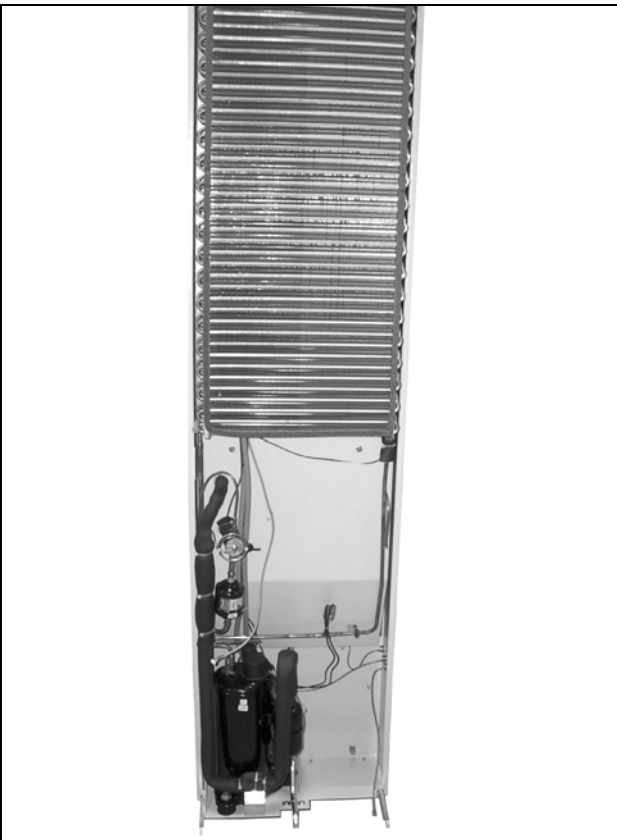

Fig. 78: Clean out the heat exchanger coil and compressor chamber using compressed air (1)

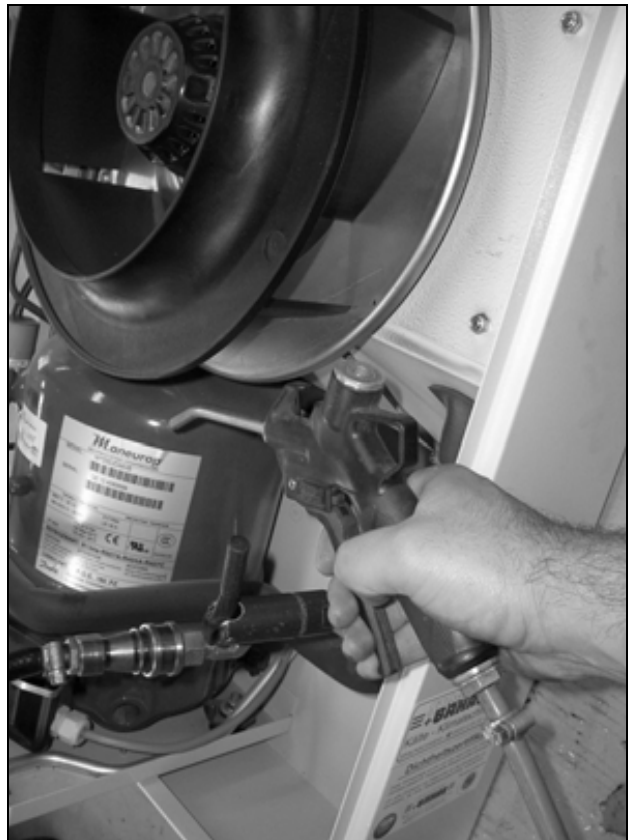

Fig. 80: Clean out the heat exchanger coil and compressor chamber using compressed air (3)

8 Storage and disposal



Caution! Risk of damage!
The cooling unit must not be subjected to temperatures above +70°C during storage.

During storage, the cooling unit must stand upright. The closed cooling circuit contains refrigerant and oil which must be properly disposed of for the sake of the environment. Disposal can be performed at the Rittal plant. Please contact us for advice.

9 Technical specifications

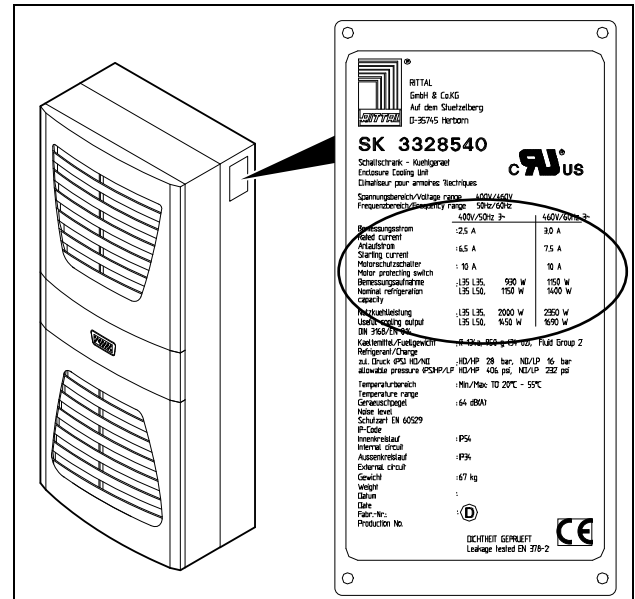

Fig. 81: Rating plate (technical specifications)

- Observe the mains connection data (voltage and frequency) as per the rating plate.
- Observe the pre-fuse as per the specifications on the rating plate.

9 Technical specifications

EN

	Unit	Model No. SK							
		3302.100	3302.110	3302.300	3302.310	–	–	–	–
Basic controller, RAL 7035	–	3302.100	3302.110	3302.300	3302.310	–	–	–	–
Basic controller, stainless steel	–	3302.200	3302.210	–	–	–	–	–	–
e-Comfort controller, RAL 7035	–	–	–	–	–	3303.500	3303.510	3304.500	3304.510
e-Comfort controller, NEMA 4X	–	–	–	–	–	3303.504	3303.514	3304.504	3304.514
e-Comfort controller, stainless steel cover	–	–	–	–	–	3303.600	3303.610	3304.600	3304.610
Rated voltage	V Hz	230, 1~, 50/60	115, 1~, 60	230, 1~, 50/60	115, 1~, 60	230, 1~, 50/60	115, 1~, 60	230, 1~, 50/60	115, 1~, 50/60
Rated current	A	1.6/1.7	3.3	1.6/1.7	4.0	2.6/2.6	5.7	3.9/4.3	8.0/8.8
Start-up current	A	3.0/3.4	8.0	4.3/5.3	12.0	5.1/6.4	11.5	12.0/14.0	26.0/28.0
Pre-fuse T	A	10.0	10.0	10.0	10.0	10.0	10.0	10.0	11.0 – 16.0
Motor circuit-breaker	–	–	–	–	–	–	–	–	–
Transformer circuit-breaker	–	–	–	–	–	–	–	–	■
Miniature circuit breaker or fuse gG (T)	–	■	■	■	■	■	■	■	–
Useful cooling output \dot{Q}_k L 35 L 35 to DIN 3168 L 35 L 50	W W	300/320 150/170	300 150	300/320 150/160	300 150	500/610 280/350	500 280	1000/1450 1050/1100	1000/1450 980/1050
Power consumption P_{el} L 35 L 35 to DIN 3168 L 35 L 50	W W	245/255 255/275	290 340	285/300 320/340	290 340	360/380 420/390	470 500	640/720 750/850	670/750 780/880
Refrigeration factor $\epsilon = \dot{Q}_k/P_{el}$		1.2	1.2	1.1	1.1	1.4	1.4	1.6	1.6
Refrigerant – Type – Filling	– g	R134a 100	R134a 100	R134a 100	R134a 95	R134a 170	R134a 170	R134a 325	R134a 325
Admissible pressure	bar	25	25	25	25	28	28	25	25
Temperature setting range	°C	+20 to +55	+20 to +55	+20 to +55	+20 to +55	+20 to +55	+20 to +55	+20 to +55	+20 to +55
Setting range	°C	+30 to +55	+30 to +55	+30 to +55	+30 to +55	+20 to +55	+20 to +55	+20 to +55	+20 to +55
Noise level	dB (A)	< 61	< 61	< 61	< 61	< 61	< 61	< 64	< 64
Protection category to EN 60 529 – Internal circuit – External circuit	– –	IP 54 IP 34							
Protection category	–	(NEMA 4X) ¹⁾							
Dimensions (W x H x D)	mm	280 x 550 x 140		525 x 340 x 153		280 x 550 x 206 (285 x 620 x 298) ¹⁾		400 x 950 x 260 (405 x 1020 x 358) ¹⁾	
Weight	kg	13	13	13	17	17 (25) ¹⁾	17 (25) ¹⁾	39 (49) ¹⁾	44 (54) ¹⁾

¹⁾ Information relevant for NEMA 4X

9 Technical specifications

EN

	Unit	Model No. SK									
e-Comfort controller, RAL 7035	–	3304.540	3305.500	3305.510	3305.540	3328.500	3328.510	3328.540	3329.500		
e-Comfort controller, NEMA 4X	–	3304.544	3305.504	3305.514	3305.544	3328.504	3328.514	3328.544	3329.504		
e-Comfort controller, stainless steel cover	–	3304.640	3305.600	3305.610	3305.640	3328.600	3328.610	3328.640	3329.600		
Rated voltage	V, Hz	400, 3~, 50/460, 3~, 60	230, 1~, 50/60	115, 1~, 50/60	400, 3~, 50/460, 3~, 60	230, 1~, 50/60	115, 1~, 50/60	400, 3~, 50/460, 3~, 60	230, 1~, 50/60		
Rated current	A	2.2/2.1	5.5/5.8	11.5/12.5	2.5/2.8	6.1/6.6	13.4/14.8	2.8/3.3	8.2/9.3		
Start-up current	A	11.5/12.7	22.0/24.0	26.0/28.0	12.2/11.3	20.0/22.0	40.0/38.0	6.8/7.8	20.0/24.0		
Pre-fuse T	A	6.3 – 10.0	16.0	14.0 – 20.0	6.3 – 10.0	16.0	18.0 – 25.0	6.3 – 10.0	16.0		
Motor circuit-breaker	–	■	–	–	■	–	–	■	–		
Transformer circuit-breaker	–	–	–	■	–	–	■	–	–		
Miniature circuit breaker or fuse gG (T)	–	–	■	–	–	■	–	–	■		
Useful cooling output \dot{Q}_k to DIN 3168	L 35 L 35 W W L 35 L 50	1000/1460 880/990	1500/1510 1150/1200	1500/1660 1150/1270	1500/1510 1230/1250	2000/2360 1620/1745	2000/2360 1620/1745	2000/2350 1450/1690	2500/2660 1840/1920		
Power consumption P_{el} to DIN 3168	L 35 L 35 W W L 35 L 50	670/820 760/930	870/980 1030/1150	1010/900 1180/1060	820/1000 980/1170	935/1055 1080/1250	965/1085 1110/1280	920/1145 1145/1395	1270/1410 1470/1700		
Refrigeration factor $\varepsilon = \dot{Q}_k/P_{el}$		1.7	1.7	1.5	1.8	2.1	2.1	2.2	2.0		
Refrigerant – Type – Filling	– g	R134a 325	R134a 600	R134a 600	R134a 600	R134a 950	R134a 950	R134a 950	R134a 950		
Admissible pressure	bar	25	25	25	25	28	28	28	28		
Temperature setting range	°C	+20 to +55	+20 to +53	+20 to +53	+20 to +55	+20 to +55 (+20 to +50) ¹⁾					
Setting range	°C	+20 to +55	+20 to +50	+20 to +50	+20 to +55	+20 to +55 (+20 to +50) ¹⁾					
Noise level	dB (A)	< 64	< 64	< 64	< 64	< 64	< 64	< 64	< 64		
Protection category to EN 60 529 – Internal circuit – External circuit	– –	IP 54 IP 34									
Protection category	–	(NEMA 4X) ¹⁾									
Dimensions (W x H x D)	mm	400 x 950 x 260 (405 x 1020 x 358) ¹⁾					400 x 1580 x 295 (405 x 1650 x 388) ¹⁾				
Weight	kg	40 (50) ¹⁾	41 (51) ¹⁾	46 (56) ¹⁾	42 (52) ¹⁾	66 (80) ¹⁾	73 (87) ¹⁾	67 (80) ¹⁾	69 (83) ¹⁾		

¹⁾ Information relevant for NEMA 4X

9 Technical specifications

EN

	Unit	Model No. SK					
e-Comfort controller, RAL 7035	–	3329.510	3329.540	3332.540	3361.500	3361.510	3361.540
e-Comfort controller, NEMA 4X	–	3329.514	3329.544	–	–	–	–
e-Comfort controller, stainless steel cover	–	3329.610	3329.640	3332.640	3361.600	3361.610	3361.640
Rated voltage	V, Hz	115, 1~, 50/60	400, 3~, 50/460, 3~, 60	400, 3~, 50/460, 3~, 60	230, 1~, 50/60	115, 1~, 60	400, 2~, 50/60
Rated current	A	17.0/20.0	3.7/3.8	4.2/4.2	2.7/2.7	5.3	1.2/1.4
Start-up current	A	44.0/42.0	6.8/7.6	9.2/11.0	6.0/9.6	12.0	3.1/3.3
Pre-fuse T	A	18.0 – 25.0	6.3 – 10.0	6.3 – 10.0	10.0	10.0	6.3 – 10.0
Motor circuit-breaker	–	–	■	■	–	–	–
Transformer circuit-breaker	–	■	–	–	–	–	■
Miniature circuit breaker or fuse gG (T)	–	–	–	–	■	■	–
Useful cooling output \dot{Q}_k to DIN 3168	L 35 L 35 L 35 L 50	W W	255/2660 1840/1920	2500/2700 1900/1950	4000/4400 3070/3570	750/790 570/570	750/790 570/570
Power consumption P_{el} to DIN 3168	L 35 L 35 L 35 L 50	W W	1300/1440 1500/1730	1295/1495 1545/1845	1720/2120 1990/2460	420/450 480/510	570 670
Refrigeration factor $\varepsilon = \dot{Q}_k/P_{el}$			1.9	1.9	2.3	1.8	1.3
Refrigerant – Type – Filling	– g	R134a 950	R134a 950	R134a 3000	R134a 280	R134a 260	R134a 280
Admissible pressure	bar	28	28	28	28	28	28
Temperature setting range	°C	+20 to +55 (+20 to +50) ¹⁾				+20 to +52	+20 to +55
Setting range	°C	+20 to +55 (+20 to +50) ¹⁾				+20 to +52	+20 to +55
Noise level	dB (A)	< 64	< 64	< 64	< 64	< 64	< 64
Protection category to EN 60 529 – Internal circuit – External circuit	– –	IP 54 IP 34					
Protection category	–	(NEMA 4X) ¹⁾					
Dimensions (W x H x D)	mm	400 x 1580 x 295 (405 x 1650 x 388) ¹⁾		500 x 1580 x 340	280 x 550 x 206		
Weight	kg	76 (90) ¹⁾	70 (83) ¹⁾	91	22	22	22

¹⁾ Information relevant for NEMA 4X

	Unit	Model No. SK		
e-Comfort controller, RAL 7035	–	3366.500	3366.510	3366.540
e-Comfort controller, stainless steel cover	–	3366.600	3366.610	3366.640
Rated voltage	V, Hz	230, 1~, 50/60	115, 1~, 50/60	400, 3~, 50/460, 3~, 60
Rated current	A	6.7/6.9	13.6/13.8	2.7/2.9
Start-up current	A	22.0/24.0	43.0/47.0	8.0/8.8
Pre-fuse T	A	10.0	14.0 – 20.0	6.3 – 10.0
Motor circuit-breaker	–	–	–	■
Transformer circuit-breaker	–	–	■	–
Miniature circuit breaker or fuse gG (T)	–	■	–	–
Useful cooling output \dot{Q}_k to DIN 3168	L 35 L 35 L 35 L 50	W W	1500/1500 1050/1100	1500/1500 980/1080
Power consumption P_{el} to DIN 3168	L 35 L 35 L 35 L 50	W W	940/1070 1115/1230	970/1120 1140/1310
Refrigeration factor $\varepsilon = \dot{Q}_k/P_{el}$			1.6	1.5
Refrigerant – Type – Filling	– g	R134a 700		
Admissible pressure	bar	28		
Temperature setting range	°C	+20 to +55		
Setting range	°C	+20 to +55		
Noise level	dB (A)	72		
Protection category to EN 60 529 – Internal circuit – External circuit	– –	IP 54 IP 34		
Dimensions (W x H x D)	mm	450 x 1590 x 195		
Weight	kg	45	49	46

10 List of spare parts

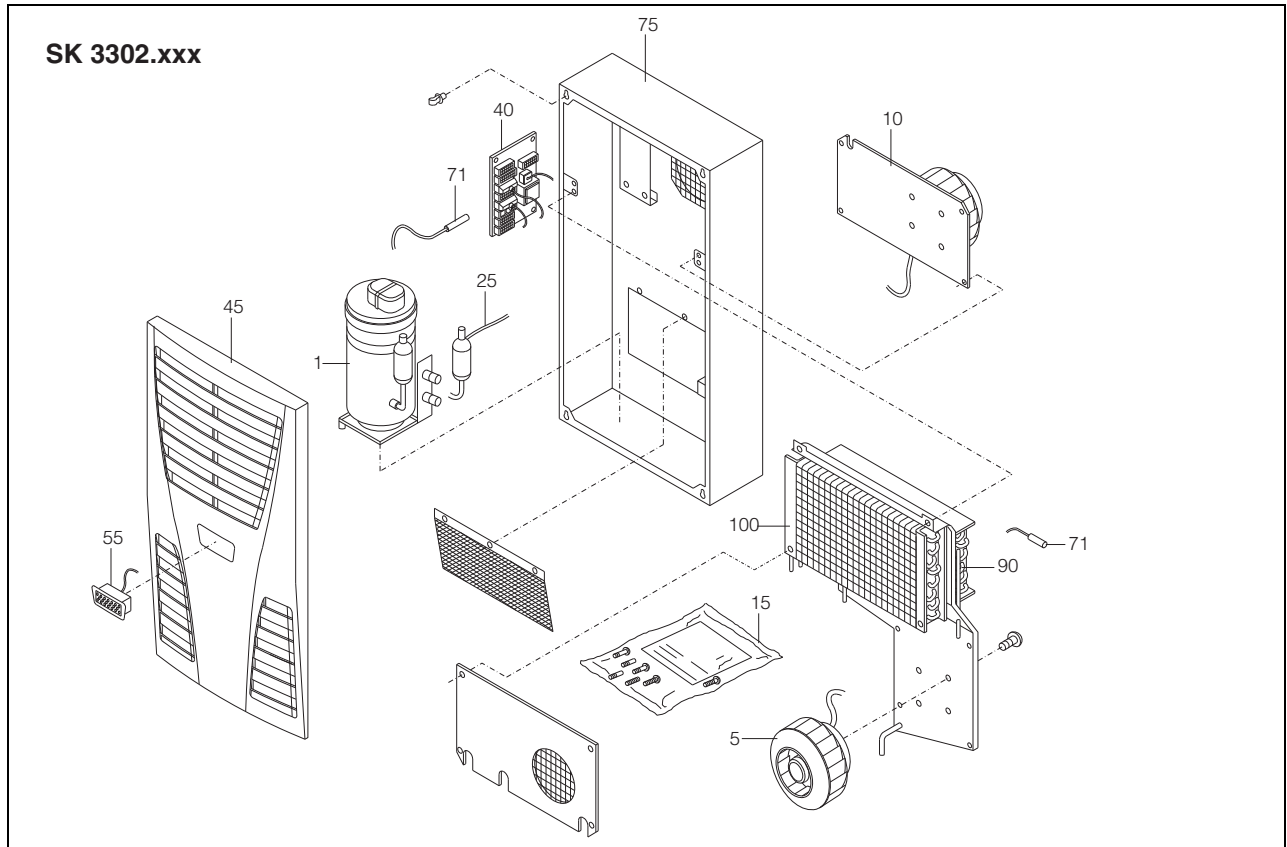

Fig. 82: Spare parts for SK 3302.xxx

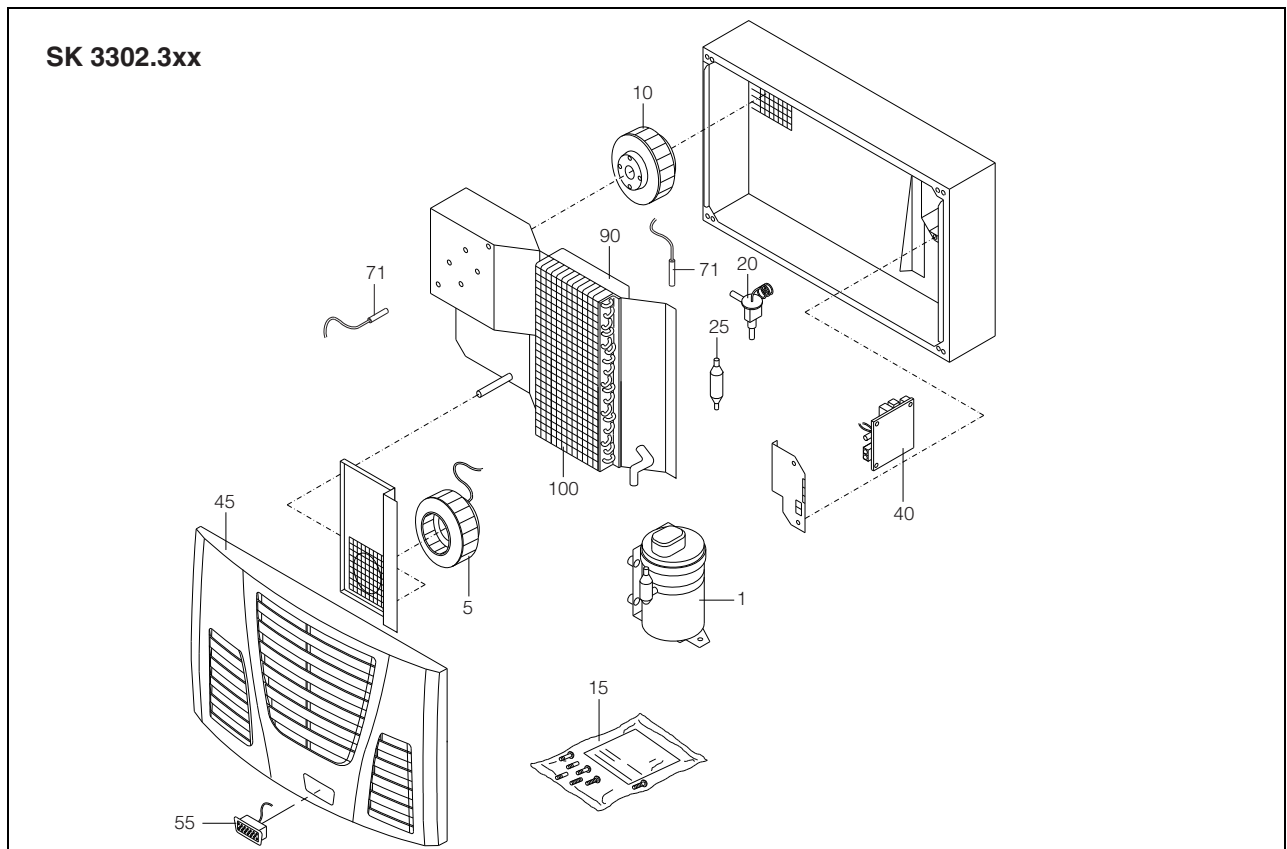

Fig. 83: Spare parts for SK 3302.3xx

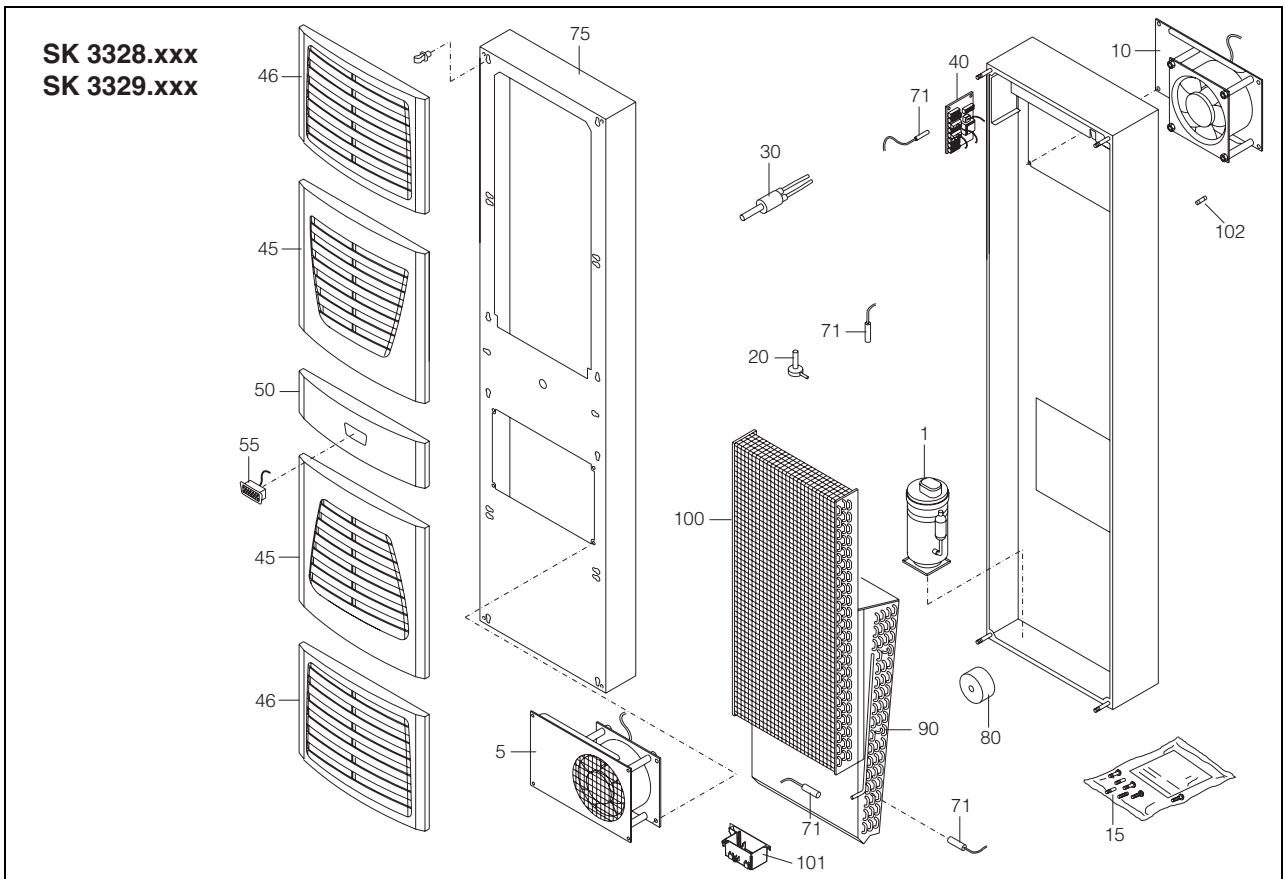

Fig. 86: Spare parts for SK 3328.xxx, SK 3329.xxx

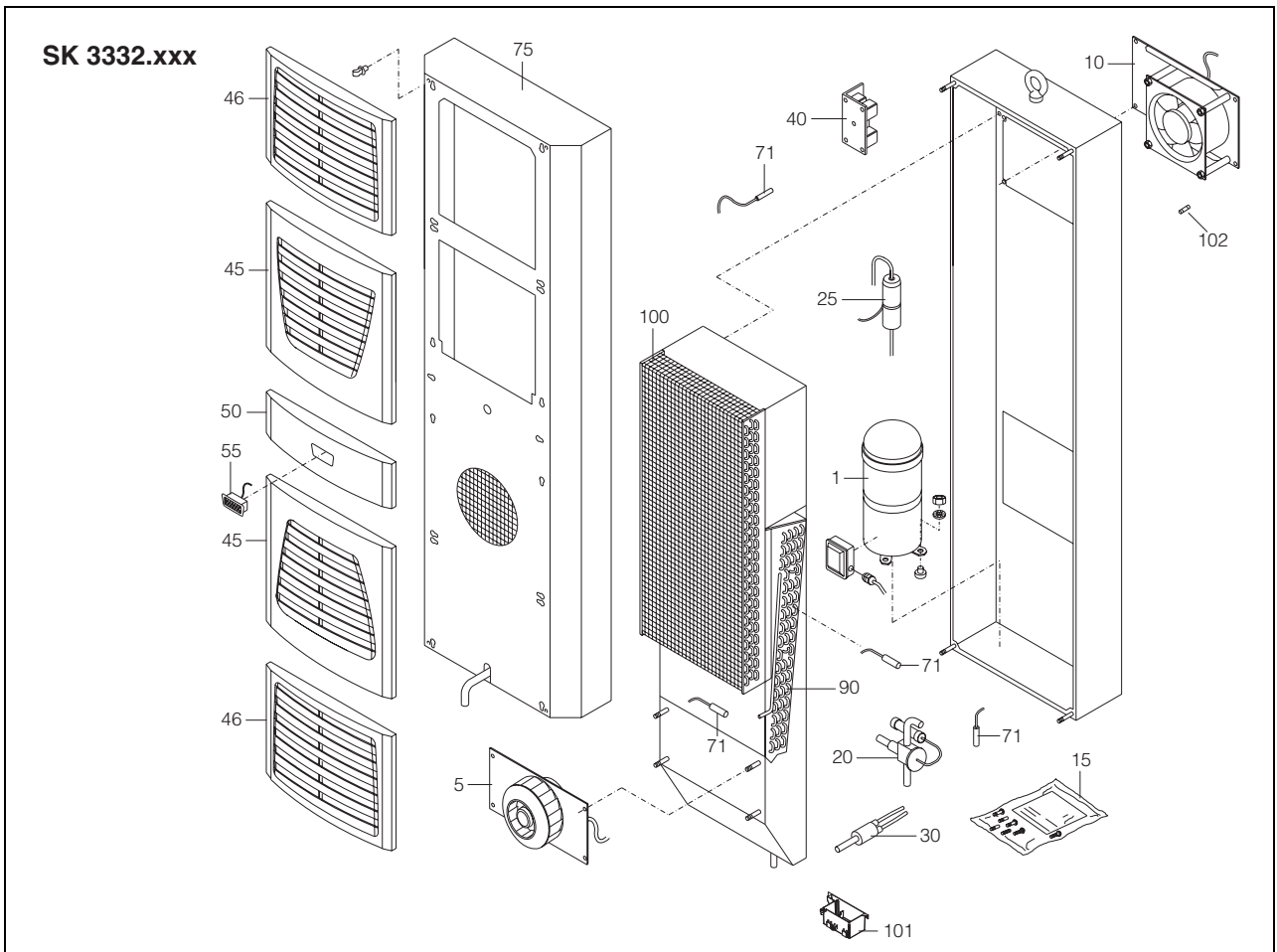

Fig. 87: Spare parts for SK 3332.xxx

10 List of spare parts

EN

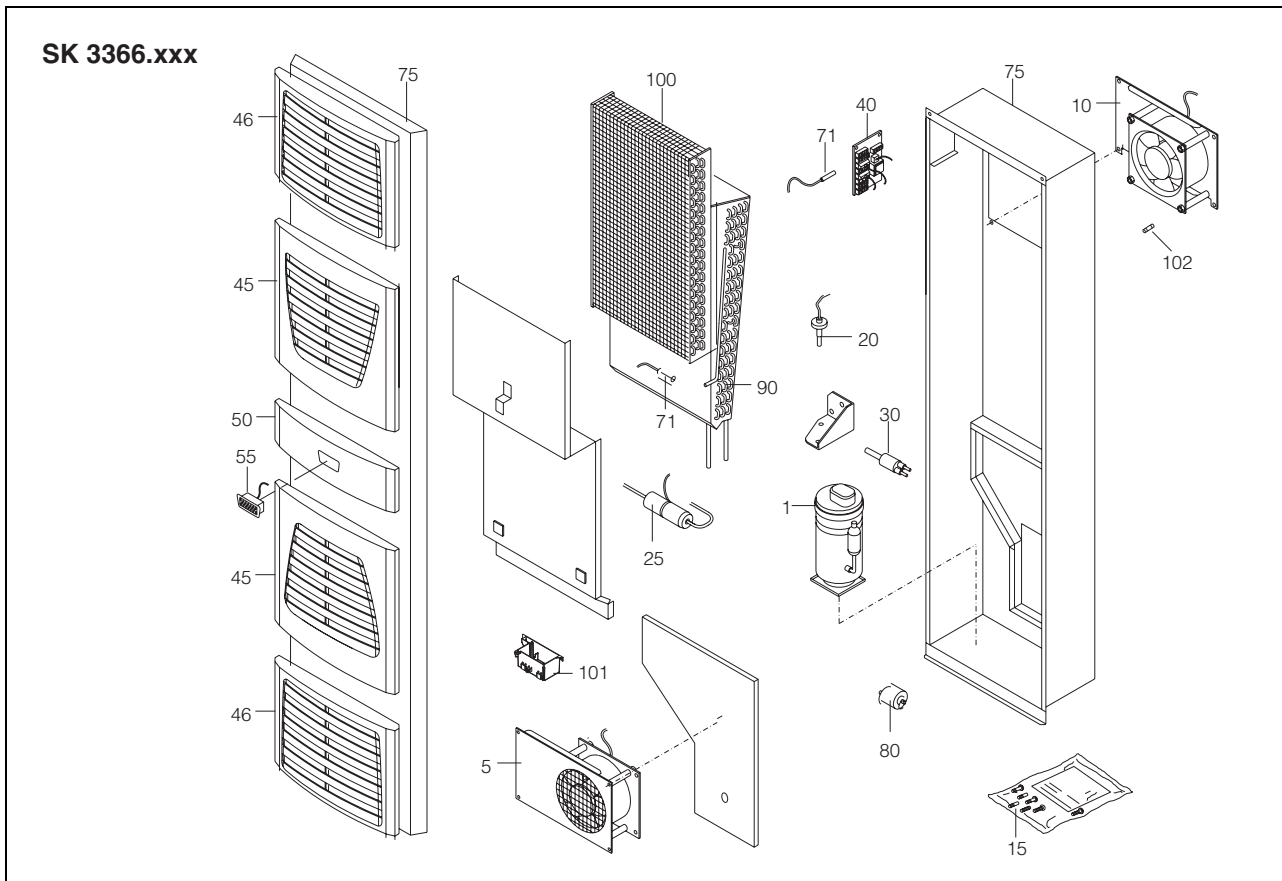

Fig. 88: Spare parts for SK 3366.xxx, SK 3377.xxx

Legend

- 1 Compressor
- 5 Condenser fan
- 10 Evaporator fan
- 15 Dispatch bag
- 20 Expansion valve
- 25 Filter dryer
- 30 PSA^H pressure-operated switch
- 40 Controller board
- 45 Louvred grille 1
- 46 Louvred grille 2
- 50 Infill panel
- 55 Display
- 71 Temperature sensor
- 75 Enclosure tray
- 80 Transformer
- 90 Evaporator coil
- 100 Condenser
- 101 Condensate evaporator
- 102 Miniature fuse, condensate evaporator (T4A; 6.3 x 32 mm)



Note:

As well as the spare part number, when ordering spare parts the following information must be provided:

- Unit model
- Fabrication number
- Date of manufacture

This information may be found on the rating plate.

11 Appendix: Cut-out and hole sizes

11.1 Dimensions for external mounting

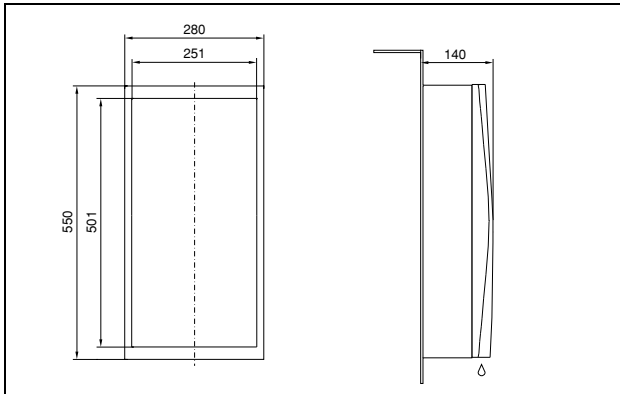

Fig. 89: SK 3302.xxx external mounting (except SK 3302.3xx)

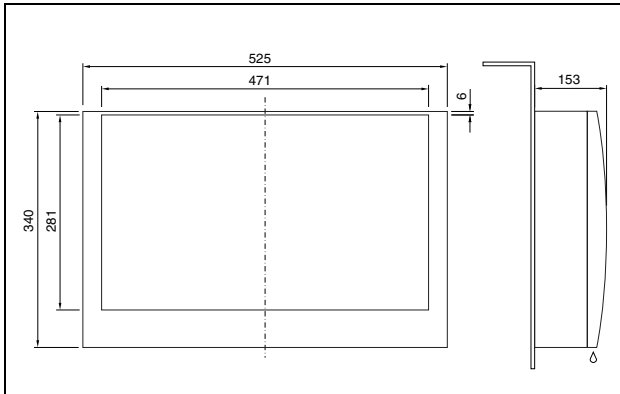

Fig. 90: SK 3302.3xx external mounting

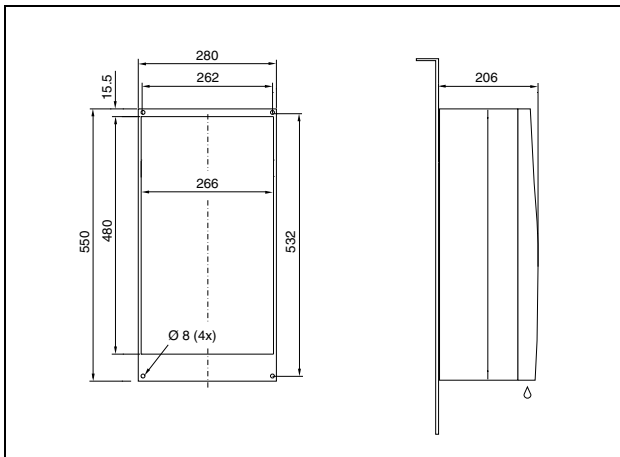

Fig. 91: SK 3303.xxx, SK 3361.xxx external mounting

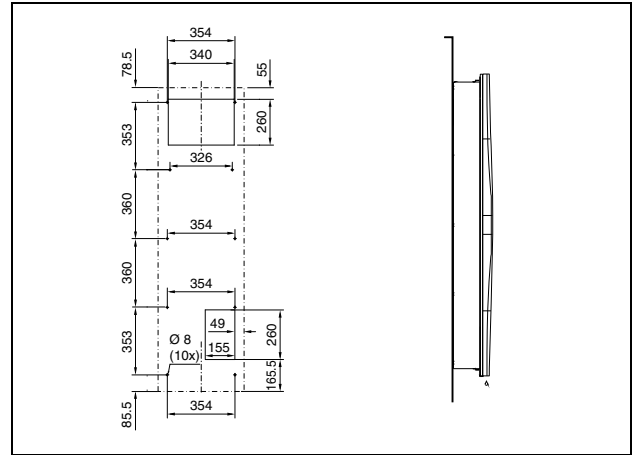

Fig. 92: SK 3366.xxx, SK 3377.xxx external mounting

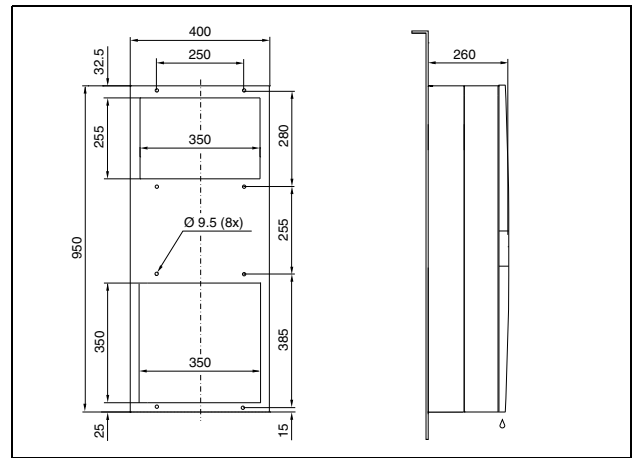

Fig. 93: SK 3304.xxx, SK 3305.xxx external mounting

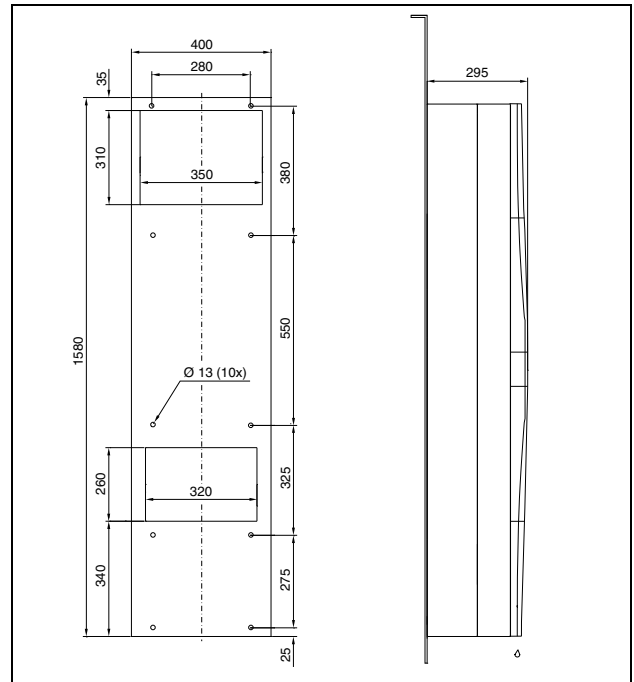

Fig. 94: SK 3328.xxx, SK 3329.xxx external mounting

11 Appendix: Cut-out and hole sizes

EN

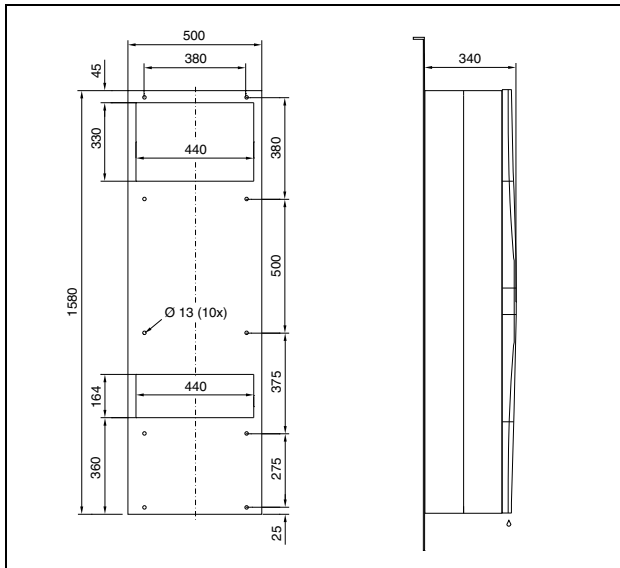

Fig. 95: SK 3332.xxx external mounting

11.2 Dimensions for partial internal mounting

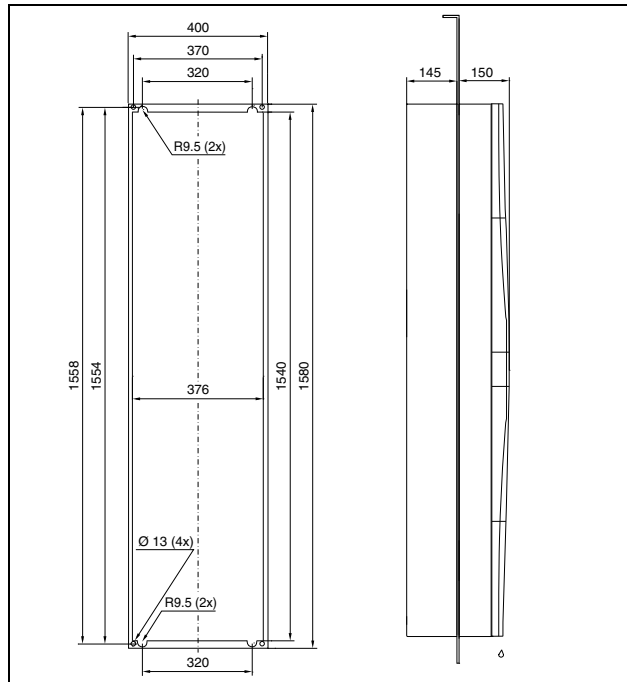

Fig. 98: SK 3328.xxx, SK 3329.xxx partial internal mounting

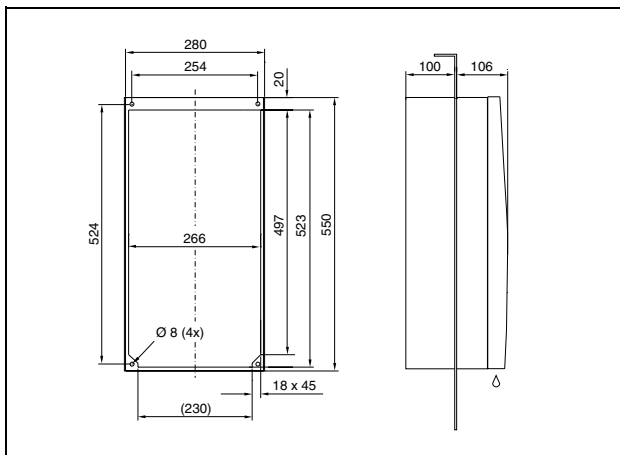

Fig. 96: SK 3303.xxx, SK 3361.xxx partial internal mounting

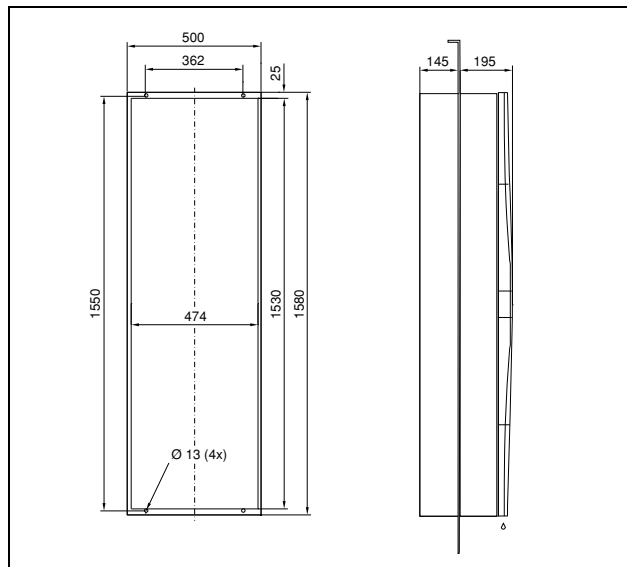

Fig. 99: SK 3332.xxx partial internal mounting

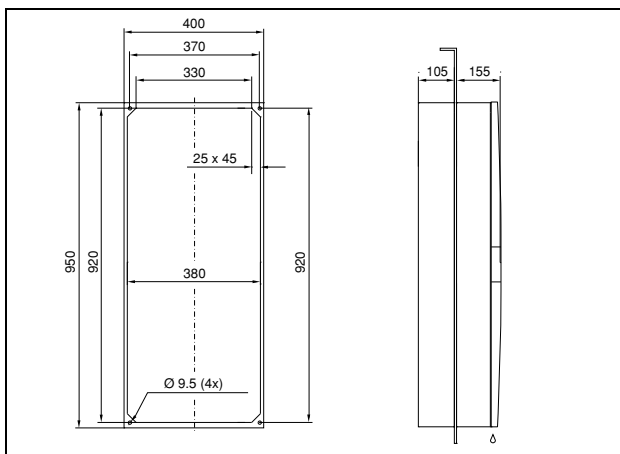

Fig. 97: SK 3304.xxx, SK 3305.xxx partial internal mounting

11 Appendix: Cut-out and hole sizes

EN

11.3 Dimensions for full internal mounting

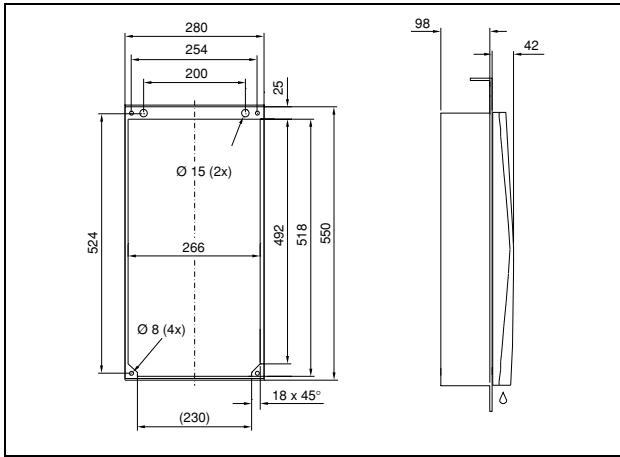

Fig. 100: SK 3302.1xx full internal mounting

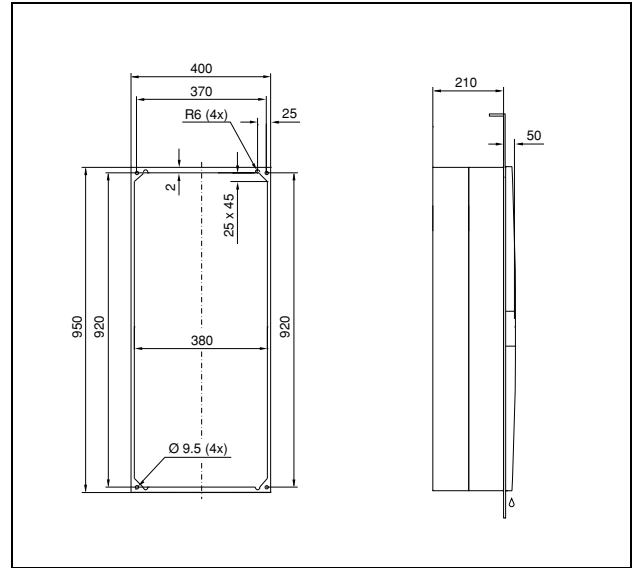

Fig. 103: SK 3304.xxx, SK 3305.xxx full internal mounting

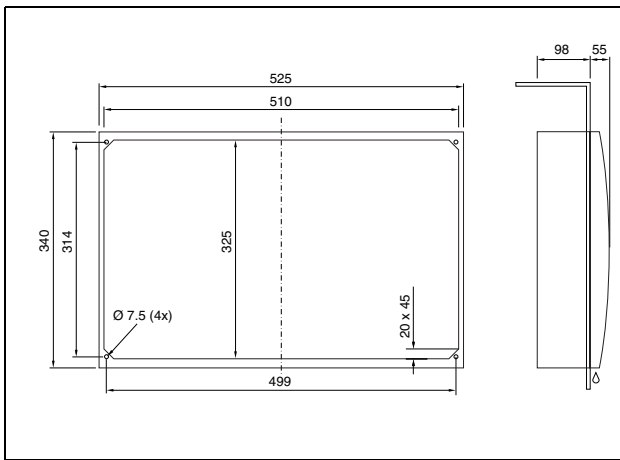

Fig. 101: SK 3302.3xx full internal mounting

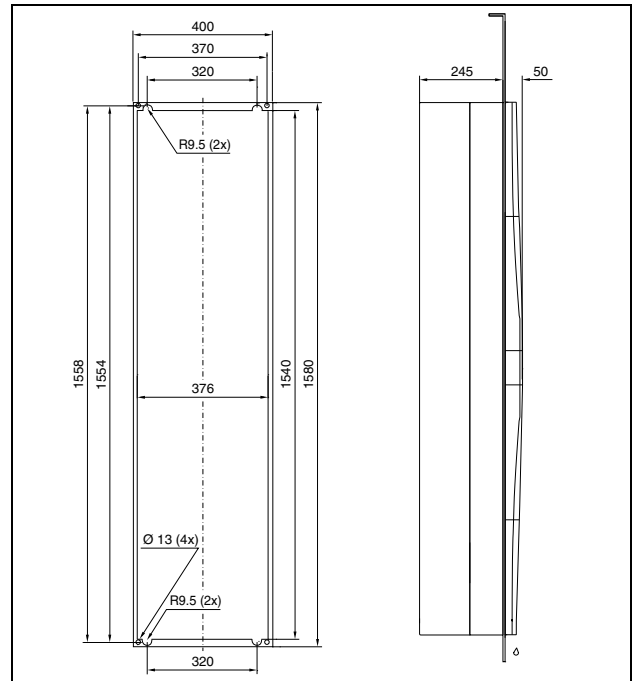

Fig. 104: SK 3328.xxx, SK 3329.xxx full internal mounting

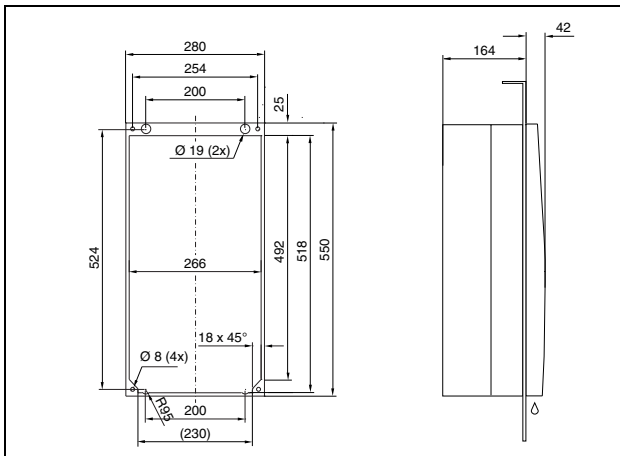

Fig. 102: SK 3303.xxx, SK 3361.xxx full internal mounting

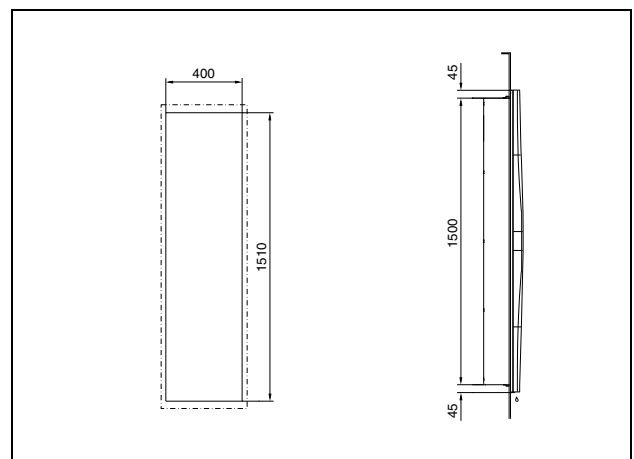

Fig. 105: SK 3366.xxx, SK 3377.xxx full internal mounting

Rittal – The System.

Faster – better – worldwide.

- Enclosures
- Power Distribution
- Climate Control
- IT Infrastructure
- Software & Services

RITTAL GmbH & Co. KG
Postfach 1662 · D-35726 Herborn
Phone +49(0)2772 505-0 · Fax +49(0)2772 505-2319
E-mail: info@rittal.de · www.rittal.com

ENCLOSURES

POWER DISTRIBUTION

CLIMATE CONTROL

IT INFRASTRUCTURE

SOFTWARE & SERVICES

FRIEDHELM LOH GROUP

