

Raychem QuickNet-RK

QUICKNET AND CERAPRO HEATING CABLE REPAIR KIT INSTALLATION INSTRUCTIONS

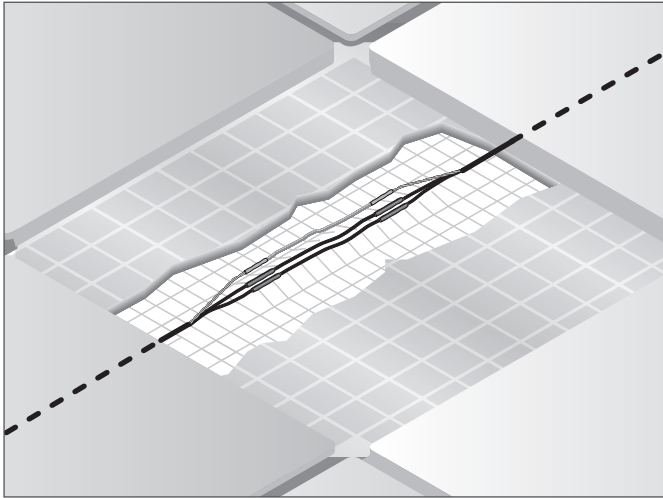

DESCRIPTION

The QuickNet-RK repair kit is for repairing QuickNet or CeraPro heating cable that is damaged during installation. The kit includes jumper wires to bridge the heating element after the damaged section is removed. The kit contents are sufficient to repair one damaged section up to 5 inches long. If more than 5 inches of cable has been damaged, the mat or cable must be replaced.

TOOLS REQUIRED

- Wire Strippers 16-26 AWG
- Gloves
- Scissors
- Heat gun (1000°F air temp with heat deflector required)
- Multimeter (capable of 200K ohms)

ADDITIONAL MATERIALS REQUIRED

- QuickNet System Installation Manual (H57704)
- CeraPro System Installation Manual (H58956)
- QuickStat-TC Thermostat Installation and Operation Manual (H58517)

OPTIONAL TILE REMOVAL TOOLS

- Grout removal tool
- Hammer

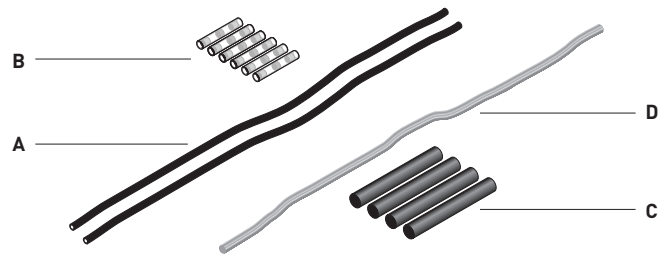

APPROVALS



KIT CONTENTS

Item	Qty	Description
A	2	Jumper wires (blue)
B	6	SolderSleeve connectors
C	4	Heat-shrinkable tubing
D	1	Ground wire (non-insulated)

WARRANTY & APPROVALS DISCLAIMER

The QuickNet-RK Repair Kit is for making minor repairs to the QuickNet and CeraPro heating cable if it is damaged during or after installation. Because the condition of the damaged mat, site conditions and installer capability can vary, Pentair Thermal Management does not warrant the

repair or warrant that the repaired floor heating system will function properly. Use of this kit voids the warranty of the repaired portion of the heating cable. Repairs should only be attempted by a qualified electrician or experienced craftsmen familiar with good electrical practices and

techniques for tile installation and removal. Contact Pentair Thermal Management for assistance.

WARNING:

SHOCK AND FIRE HAZARD. If the QuickNet mat or CeraPro cable is damaged or not installed properly, fire or shock could occur resulting in serious personal injuries or damage to property. You must carefully follow the warnings and instructions contained in these instructions and the QuickNet Installation Manual (H57704) or CeraPro System Installation Manual (H58956). Contact Pentair Thermal Management for assistance.

- The QuickStat-TC thermostat must be used. It has a ground-fault circuit interrupter (GFCI) to prevent electric shock.
- The QuickNet-RK repair kit must be installed by qualified personnel familiar with generally accepted construction techniques and safe electrical practices. The installation must comply with all national and local electrical codes. If you are

unfamiliar with these requirements, contact a licensed electrician.

- Electric wiring and the heating mat are installed in the floor. Be sure that the floor is not penetrated by nails, screws, or similar devices that can cause damage on first installation or during subsequent floor repairs in the future.
- Do not use this Repair Kit to splice different QuickNet mats or CeraPro cable kits together. It is designed only to repair a damaged section of heating cable in a single mat or cable kit.
- The QuickNet and CeraPro heating cable cannot be cut to length, crossed over itself, or installed closer than the spacing in the mat or specified in the installation manuals.
- QuickNet mats and CeraPro cables can be installed over wood, with or without a backer-board; or on concrete. The mat is then

INSTALLATION GUIDELINES:

- embedded in mortar and covered with your particular flooring type following the manufacturer's instructions. QuickNet and CeraPro **MUST NOT** be installed beneath carpeted, linoleum or other types of floors not mentioned previously.
- Do not step directly on or damage the heating cable during installation.
- Do not install the QuickNet mat and CeraPro cable mat across expansion joints.
- Follow the manufacturer's instructions for installing your finished flooring.
- Do not allow heating cable, cold lead, or floor temperature sensor to cross over themselves or each other.

1

- Turn off the power to the floor heating system at the circuit breaker before starting any repair work.

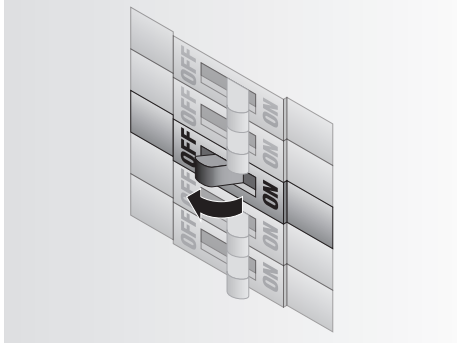

2

- Disconnect the cold leads, power wires and floor sensor leads from the the QuickStat-TC Thermostat. This provides additional safety and allows for the testing required in later steps.

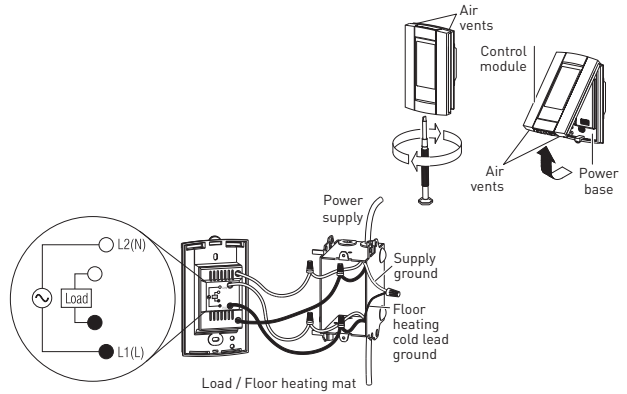

3

- If the damaged section has not been installed in mortar, proceed to Step 7.
- Remove the tile above the damaged section by removing the grout with a removal tool, being careful not to further damage the heating cable. Do not use a knife or chisel.

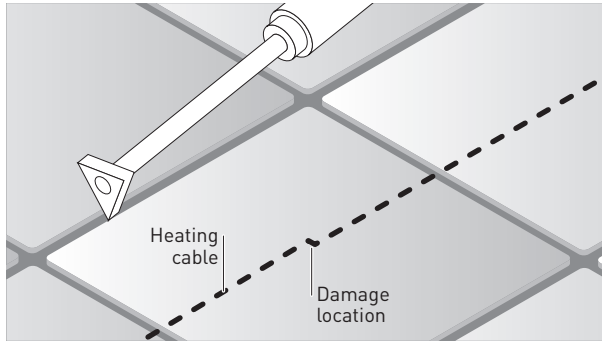

4

- Once the grout is removed, carefully break away the tile using a hammer.

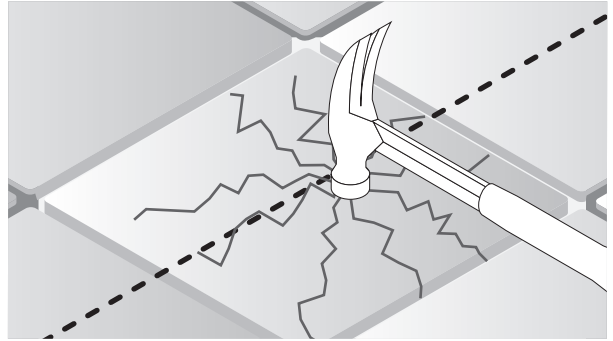

5

- Remove any broken tile and vacuum other debris from the exposed surface to locate the damaged heating cable section.

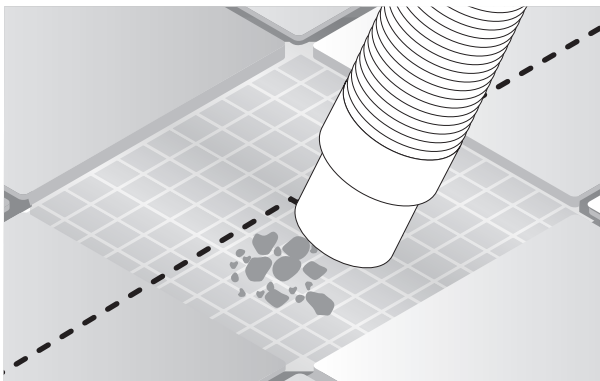

6

- To expose the damaged section, break mortar away from the heating cable with the hammer, making sure not to damage the cable.

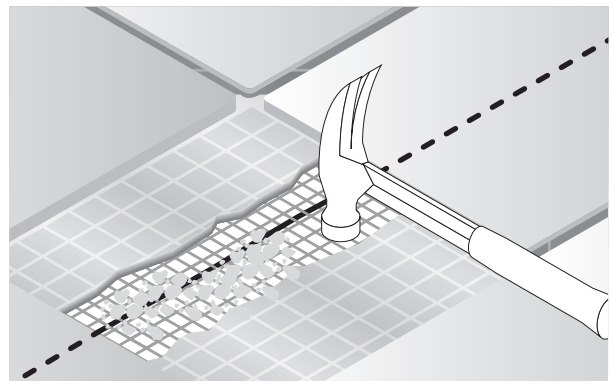

7

- Remove sufficient mortar to expose 4-5 inches of heating cable on either side of the damage. Using scissors, cut the mesh from the cable to provide room to install the splice.

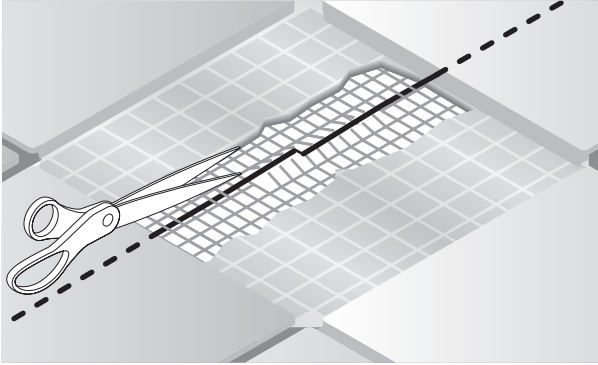

8

- Remove at least 3 inches, and up to 5 inches of heating cable including the damaged section leaving two protruding ends of heating cable. If more than 5 inches of cable has been damaged, the mat or cable must be replaced.

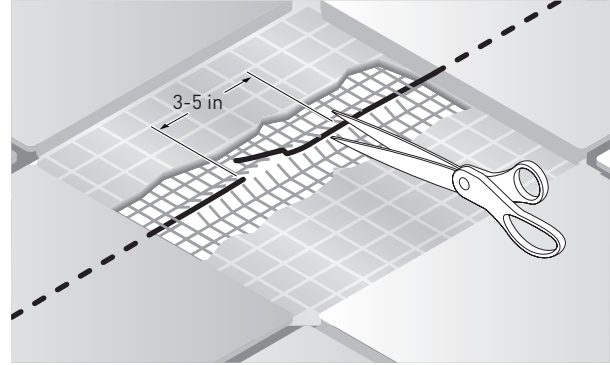

9

- Remove the damaged section.

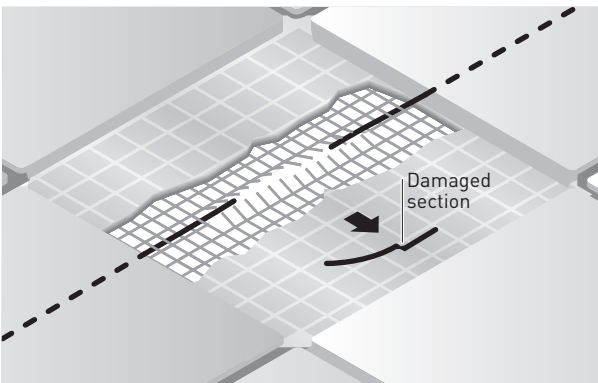

10

- Using the 16 AWG opening on the wire strippers carefully score the outer jacket, 2 inches from the end of both exposed heating cable ends.

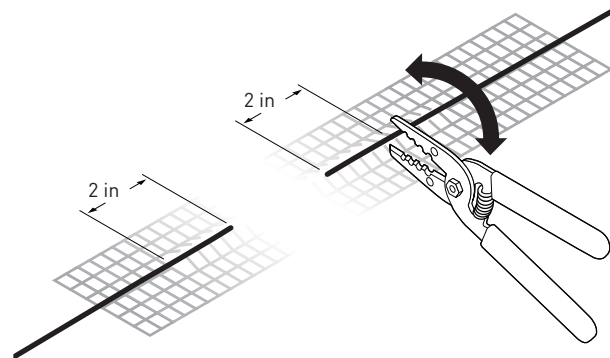

11

- Flex the cable to break the insulation at the score.

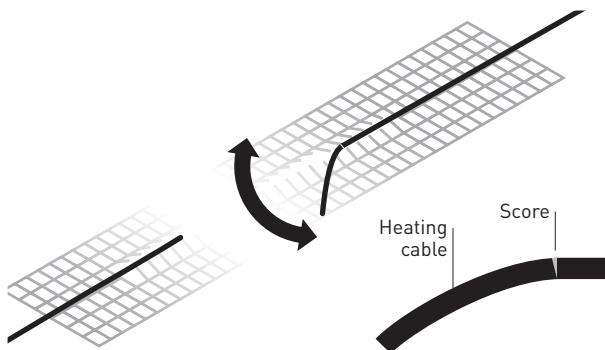

12

- Using the high setting on the heat gun, heat the jacket to loosen the insulation.

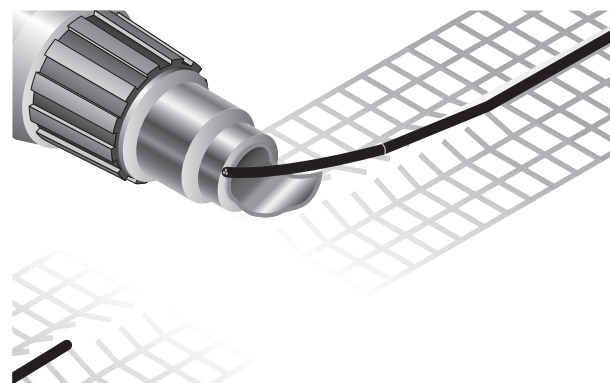

13

- While the cable is still hot, use strippers to remove the outer jacket and foil layer to expose the heating elements.
- Cut off the colored thread.

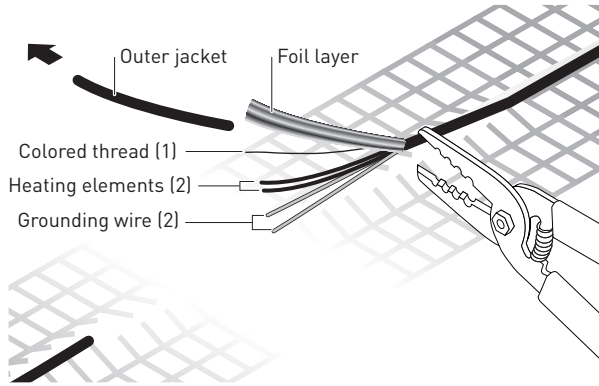

14

- Twist two ground wires together.

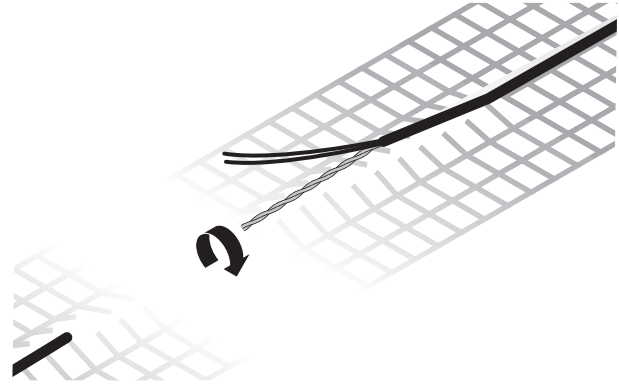

15

- Heat only 1/2 inch of the insulated ends of the heating elements to soften.

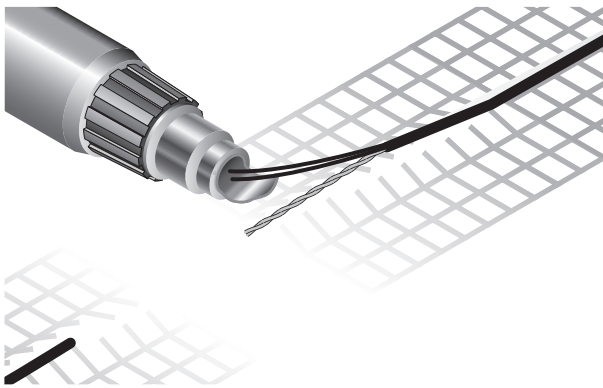

16

- While the wires are still hot, use the wire strippers to remove 1/2 inch of the outer insulation to expose the heating elements.

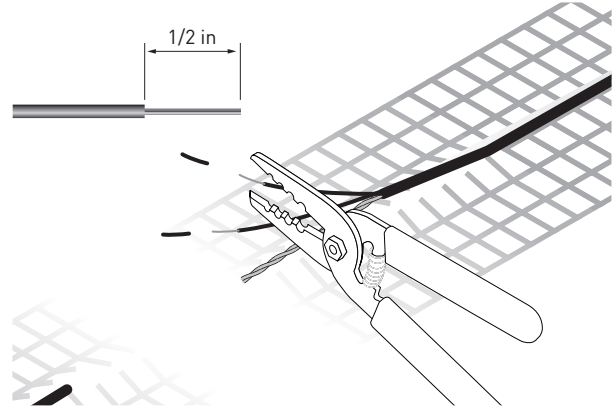

17

- Repeat steps 10 - 16 for other exposed heating cable end.

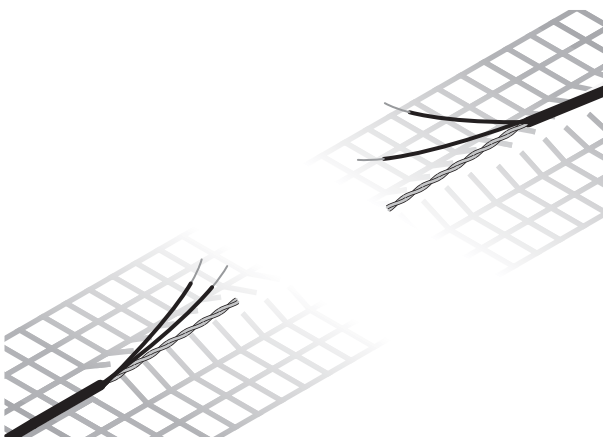

18

- Test both ends of the heating cable using this insulation resistance test to verify there is not further damage to the heating cable.
 1. Connect the ground wire to the black lead and both power wires to the red lead of the multimeter.
 2. Make sure the meter reads "Open" or "OL". If you get a different reading, contact Pentair Thermal Management at (800) 545-6258.
 3. Record these readings on the Commissioning Record (page 8).

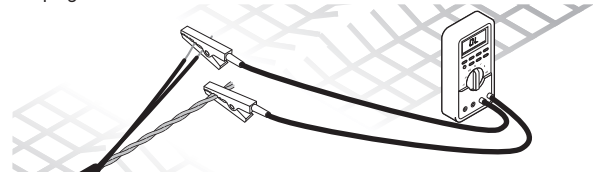

19

- Cut jumper wires to length allowing for 1/2 inch overlap on each end as shown.

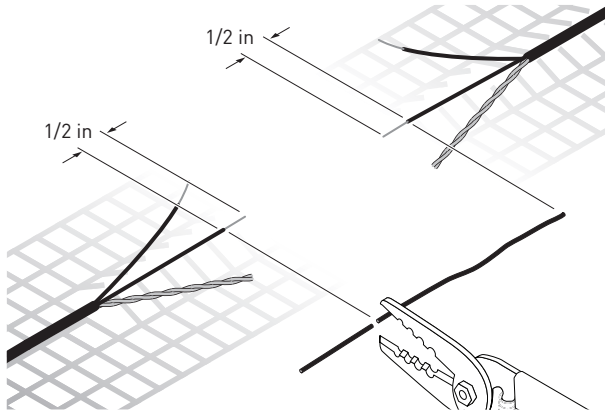

20

- Strip 1/2 inch of insulation off both ends of each jumper wire.

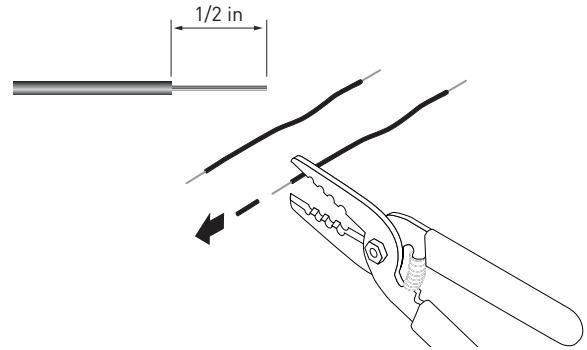

21

- Slide SolderSleeve connector onto one heating wire.
- Insert jumper wire into SolderSleeve connector.

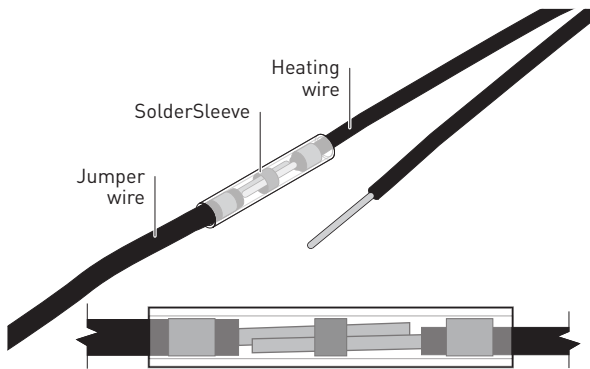

22

- Heat SolderSleeve connectors until solder and adhesive have melted. (The colored solder ring will turn clear when melted.)
- Allow to cool, then repeat for second jumper wire.

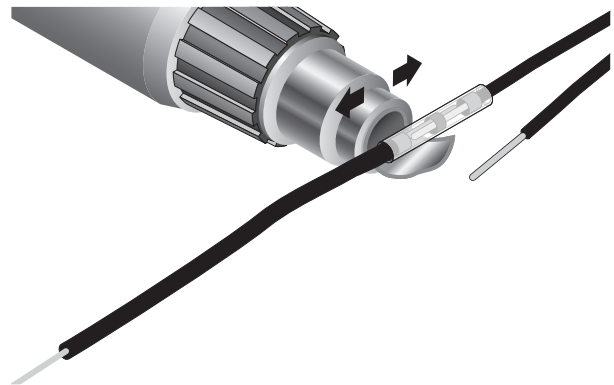

23

- Slide two heat-shrinkable tubes onto each jumper wire.

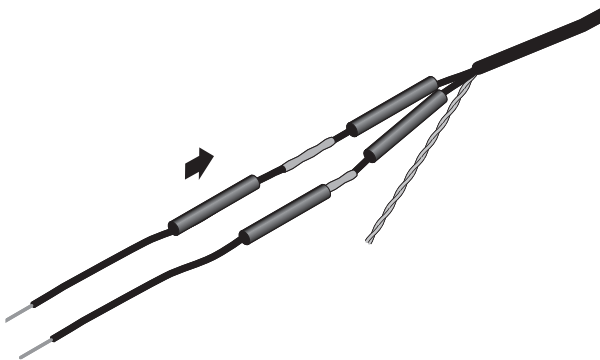

24

- Slide SolderSleeve connector onto one heating wire.
- Insert jumper wire into SolderSleeve connector.

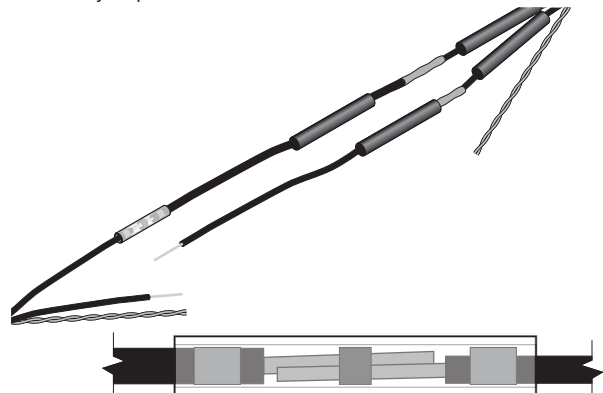

25

- Heat SolderSleeve connector until solder and adhesive have melted.
- Allow to cool, then repeat for second jumper wire.

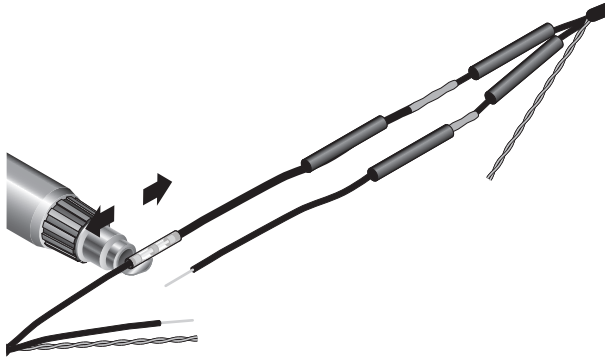

26

- Center the 4 black heat-shrinkable tubes over the installed SolderSleeve connectors.
- Using the heat gun, shrink in place.

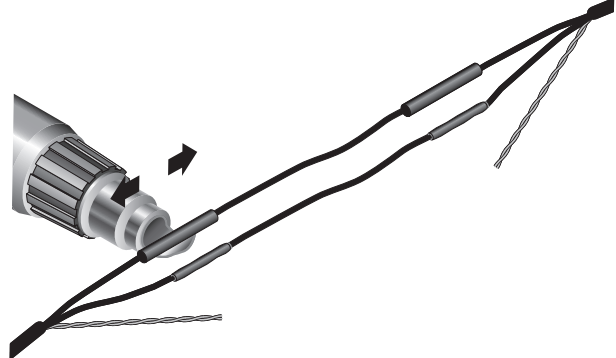

27

- Cut ground jumper to length, allowing 1/2 inch overlap on each end of twisted grounding wire.

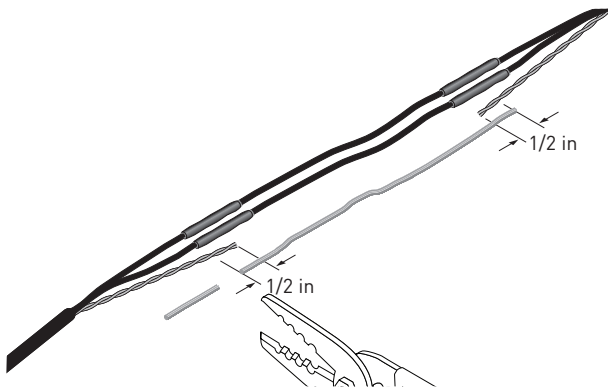

28

- Slide SolderSleeve connectors onto ground wires and jumper.



29

- Heat SolderSleeve connectors until solder has melted.

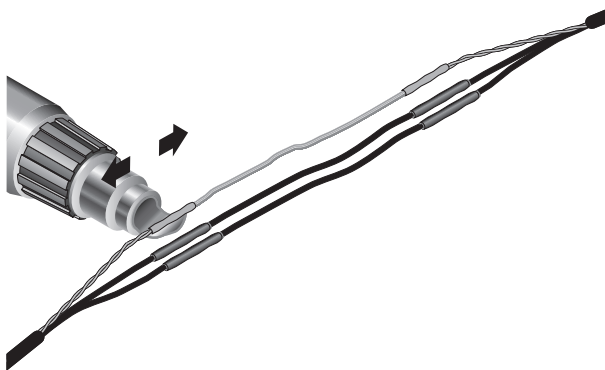

30

- Before and after re-installing the mortar and tile perform the three standard commissioning tests from the cold lead at the QuickStat-TC Thermostat and record the results in the commissioning log.
- Continue the installation following the appropriate system (QuickNet or CeraPro) and QuickStat-TC Installation manuals.

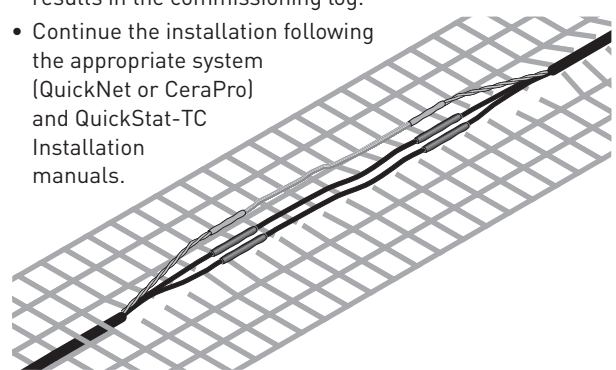

Once the splice is completed, conduct the following three commissioning tests on this page and record the values on the QuickNet-RK Commissioning Record (on page 9). Retain these readings with the original Commissioning Record.

Commissioning Tests

1 Insulation Resistance Test

 **Note:** For the extended 15-year limited warranty to apply, you must perform these tests, record the results on the Commissioning Record, and retain a copy of the record. You must perform the Insulation Resistance Test, the Heating Cable Resistance Test, and the Sensor Resistance Test three times during the installation process:

1. After you make the repair.
2. After you embed the mat or cable in mortar but before you install the flooring material.
3. After the flooring material has been installed.

This test ensures that the insulating jackets of the mat are not damaged. A low value indicates the mat has been damaged and must be replaced.

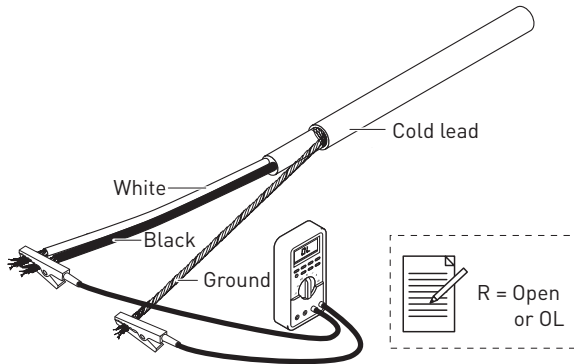

1. Set your multimeter to the highest range.
2. Connect the ground wire to the black lead and both power wires to the red lead of the multimeter.
3. Make sure the meter reads "Open" or "OL."
4. Record these readings on the Commissioning Record.

2 Heating Cable Resistance Test

This test measures the resistance of the mat and is used to determine circuit integrity.

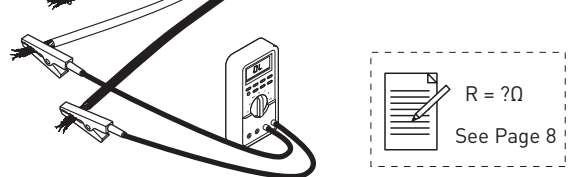

1. Set your multimeter to the 200 ohm range.
2. Connect the multimeter leads to the black and white cold lead wires.
3. Compare this resistance reading to the resistance specified in the table on page 8. The value should be within $\pm 10\%$. If you get a different reading, contact Pentair Thermal Management at 800-545-6258.
4. Note these readings on the Commissioning Record.

3 Sensor Resistance Test

This test measures the resistance of the floor sensor and is used to verify the sensor integrity.

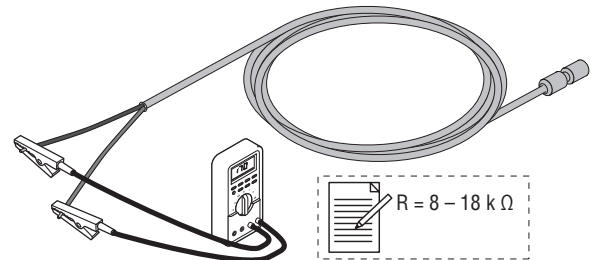

1. Set your multimeter to the 200 K ohm range.
2. Connect the multimeter leads to the sensor.
3. Make sure the meter reads between 8–18 KΩ. If you get a different reading, contact Pentair Thermal Management at 800-545-6258.
4. Record these readings on the Commissioning Record.

 **Note:** The range used in the Sensor Resistance Test (K ohm) is different from the one used in the other two commissioning tests.

AVAILABLE QUICKNET HEATING MAT SIZES

Catalog number	Heated area		Mat dimensions	Power Output (W)			Current (A)	Resistance (Ohms)
	ft ²	m ²		120 V	208 V	240 V		
120 V QuickNet Standard Kit (with thermostat)								
QUICKNET-010-1	10	0.9	20 in x 6.2 ft	120			1	120
QUICKNET-015-1	15	1.4	20 in x 9.2 ft	180			1.5	80
QUICKNET-020-1	20	1.9	20 in x 12.1 ft	240			2	60
QUICKNET-025-1	25	2.3	20 in x 15.1 ft	300			2.5	48
QUICKNET-030-1	30	2.8	20 in x 18.4 ft	360			3	40
QUICKNET-035-1	35	3.3	20 in x 21.3 ft	420			3.5	35
QUICKNET-040-1	40	3.7	20 in x 24.3 ft	480			4	30
QUICKNET-045-1	45	4.2	20 in x 27.5 ft	540			4.5	27
QUICKNET-050-1	50	4.6	20 in x 30.5 ft	600			5	24
QUICKNET-060-1	60	5.6	20 in x 36.4 ft	720			6	20
QUICKNET-070-1	70	6.5	20 in x 42.7 ft	840			7	17
QUICKNET-080-1	80	7.4	20 in x 48.9 ft	960			8	15
QUICKNET-090-1	90	8.4	20 in x 55 ft	1080			9	13
QUICKNET-100-1	100	9.3	20 in x 61 ft	1200			10	12
120 V Extension Kit (without thermostat)								
QUICKNET-010X-1	10	0.9	20 in x 6.2 ft	120			1	120
QUICKNET-015X-1	15	1.4	20 in x 9.2 ft	180			1.5	80
QUICKNET-020X-1	20	1.9	20 in x 12.1 ft	240			2	60
QUICKNET-025X-1	25	2.3	20 in x 15.1 ft	300			2.5	48
QUICKNET-030X-1	30	2.8	20 in x 18.4 ft	360			3	40
QUICKNET-035X-1	35	3.3	20 in x 21.3 ft	420			3.5	35
QUICKNET-040X-1	40	3.7	20 in x 24.3 ft	480			4	30
QUICKNET-045X-1	45	4.2	20 in x 27.5 ft	540			4.5	27
QUICKNET-050X-1	50	4.6	20 in x 30.5 ft	600			5	24
QUICKNET-060X-1	60	5.6	20 in x 36.4 ft	720			6	20
QUICKNET-070X-1	70	6.5	20 in x 42.7 ft	840			7	17
QUICKNET-080X-1	80	7.4	20 in x 48.9 ft	960			8	15
QUICKNET-090X-1	90	8.4	20 in x 55 ft	1080			9	13
QUICKNET-100X-1	100	9.3	20 in x 61 ft	1200			10	12
208 V or 240 V QuickNet Standard Kit (with thermostat)								
QUICKNET-050-2	50	4.6	20 in x 30.5ft		450	600	2.5	96
QUICKNET-060-2	60	5.6	20 in x 36.4 ft		540	720	3	80
QUICKNET-080-2	80	7.4	20 in x 48.9 ft		720	960	4	60
QUICKNET-100-2	100	9.3	20 in x 61 ft		900	1200	5	48
208 V or 240 V Extension Kit (without thermostat)								
QUICKNET-050X-2	50	4.6	20 in x 30.5 ft		450	600	2.5	96
QUICKNET-060X-2	60	5.6	20 in x 36.4 ft		540	720	3	80
QUICKNET-080X-2	80	7.4	20 in x 48.9 ft		720	960	4	60
QUICKNET-100X-2	100	9.3	20 in x 61 ft		900	1200	5	48

AVAILABLE CERAPRO HEATING CABLES

Catalog number	Heated area		Cable Length		Power Output (W)			Current (A)	Resistance (Ohms)
	ft ²	m ²	ft	m	120 V	208 V	240 V		
120 V CeraPro Cable Kits									
CPCABLE-010-1	10	0.9	38.1	11.6	120			1	120
CPCABLE-015-1	15	1.4	61.0	18.6	180			1.5	80
CPCABLE-020-1	20	1.9	76.4	23.3	240			2	60
CPCABLE-025-1	25	2.3	95.9	29.2	300			2.5	48
CPCABLE-030-1	30	2.8	114.5	34.9	360			3	40
CPCABLE-035-1	35	3.3	137.2	41.8	420			3.5	35
CPCABLE-040-1	40	3.7	152.6	46.5	480			4	30
CPCABLE-045-1	45	4.2	168.2	51.3	540			4.5	27
CPCABLE-050-1	50	4.6	190.6	58.1	600			5	24
CPCABLE-060-1	60	5.6	228.3	69.6	720			6	20
CPCABLE-070-1	70	6.5	266.7	81.3	840			7	17
CPCABLE-080-1	80	7.4	304.8	92.9	960			8	15
CPCABLE-090-1	90	8.4	342.8	104.5	1080			9	13
CPCABLE-100-1	100	9.3	380.9	116.1	1200			10	12
208 V/240 V CeraPro Cable Kits									
CPCABLE-050-2	50	4.6	190.6	58.1		450	600	2.5	120
CPCABLE-060-2	60	5.6	228.3	69.6		540	720	3	80
CPCABLE-080-2	80	7.4	304.8	92.9		720	960	4	120
CPCABLE-100-2	100	9.3	380.9	116.1		900	1200	5	80

QUICKNET-RK CABLE REPAIR COMMISSIONING RECORD (retain this record)

Installer

Date of commissioning	Company
Name of installer	
Street	
City	Postal code
Phone (office)	Phone (mobile)
Fax	Email
Website	

Project Data

Customer name					
Address					
Product	QuickNet			CeraPro	
Subfloor type (circle one)	Wood	Concrete			
Floor covering (circle one)	Ceramic tile	Natural stone	Laminate	Engineered wood	
Wood flooring installation method (circle one)	Floating		Gluedown		
Room type (circle one)	Kitchen	Bathroom	Entryway	Shower	Other
Rated voltage (circle one)	120 V	208 V	240 V		

	Number	Mat 1	Mat 2
Product details	Catalog number		
	Batch date (from box or cord label)		

Insulation resistance (see Figure on page 7)	After making the repair
	After embedding in mortar
	After floor covering

Heating cable resistance (see Figure on page 7)	After making the repair
	After embedding in mortar
	After floor covering

Sensor resistance (see Figure on page 7)	After making the repair
	After embedding in mortar
	After floor covering

Installer:	Please leave this record with homeowner
Homeowner:	You must keep a copy of the completed Commissioning Record in order for the 15-year limited warranty extension to apply.



WWW.PENTAIRTHERMAL.COM

NORTH AMERICA
PENTAIR THERMAL MANAGEMENT LLC

Tel: +1.800.545.6258
Fax: +1.800.527.5703
Tel: +1.650.216.1526
Fax: +1.650.474.7711
thermal.info@pentair.com

EUROPE, MIDDLE EAST, AFRICA
PENTAIR THERMAL MANAGEMENT BELGIUM NV

Tel: +32.16.213.511
Fax: +32.16.213.603
thermal.info@pentair.com

ASIA PACIFIC
PENTAIR THERMAL (SHANGHAI) CO. LTD

Tel: +86.21.2412.1688
Fax: +86.21.5426.2917
cn.thermal.info@pentair.com

LATIN AMERICA
PENTAIR THERMAL MANAGEMENT LLC

Tel: +1.713.868.4800
Fax: +1.713.868.2333
thermal.info@pentair.com

Pentair, QuickNet, CeraPro and QuickStat are owned by Pentair or its global affiliates. All other trademarks are the property of their respective owners. Pentair reserves the right to change specifications without prior notice.