

TORK[®]

INSTRUCTION MANUAL



DIGITAL TIME SWITCH 24 HOUR

DG180A
DG280A
DG280A-24



FOR TECHNICAL SUPPORT:
888.500.4598

A DIVISION OF **NSI** NSI INDUSTRIES, LLC
USA • 800.321.5847 • www.nsiindustries.com



MLI-199(A)

TABLE OF CONTENTS

Section	Page
Installation Instructions and Capabilities	1
1.0 Clock Format	2
2.0 Clock Set Mode	2
3.0 Date Set Mode	2
4.0 Daylight Saving Time.	3
4.1 To Modify Daylight Savings Dates	3
5.0 Duty Cycle and Signal	4
5.1 To set Duty Cycle and Signal	5
6.0 Schedule Set Mode	6
6.1 Setting Hours and Minutes	6
7.0 Skip Day Mode	7
7.1 To set Skip Day Mode	8
8.0 Review, Modify, and Delete	10
Override Mode.	10
Wiring Diagram	13
Schedule Sheets	14-16

**TORK MODEL
DG180A/DG280A/DG280A-24
7 DAY DIGITAL TIME SWITCH**

**READ INSTRUCTIONS CAREFULLY BEFORE
ATTEMPTING TO INSTALL TIME SWITCH. SEE**

WARNING ON FRONT PANEL – Failure to comply with instructions could result in personal injury and/or property damage.

INSTALLATION:

UNIT IS TO BE INSTALLED BY A LICENSED ELECTRICIAN

1. Remove unit from enclosure by pushing the inside tab (located near the outside hasp) to the right. Swing unit to left and remove.
2. Mount the enclosure at eye level using screws or other suitable fastening device. Bring supply and load wires in through or side knockouts. **DO NOT USE TOP.**
3. Reinstall unit by reversing step #1 above and connecting wires to units as per suggested wiring diagrams at back of manual.
4. Unit should be programmed with AC power. Do not program under super cap back up power.

AT POWER UP;

Connect unit to main power source prior to entering the settings. When powering up the unit for the first time, allow 1-2 minutes for super cap to charge and the display will show 12 HOUR. Press reset button after 2 minutes if screen is blank.

CAPABILITIES

- 24 hour scheduling
- 56 set points
- 2 Duty cycle or signal durations (maximum 24 hours)
- Unique "Skip Day" cycle pattern (repeats for up to 31 day cycles)

FEATURES

Daylight saving - Automatic (user selectable)

Leap year - Automatic compensation

Power outage - Permanent schedule retention. Super capacitor provides 7 days of real time back up.

Manual override - Until the next scheduled event

AM/PM or 24 hour format - user selectable

Multi-Voltage Input: 120 – 277VAC

1.0 CLOCK FORMAT

The first time unit is powered up, it will display a flashing 12 Hour. Use **HOUR** key to set clock format to either 12 Hour (AM/PM) or 24 Hour. Press the **ENTER** key.

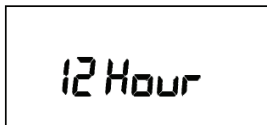

2.0 CLOCK SET MODE

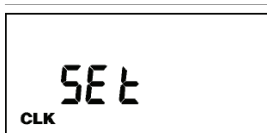

Press **HOUR** and **MIN** to advance to the present hour and minutes. Check AM/PM, and press **ENTER**.

3.0 DATE SET MODE



Press **MONTH**, **DATE**, and **YEAR** key to advance to the desired month, date and year, then press **ENTER**.

NOTE: The day of the week will automatically set once the date is entered.

4.0 DAYLIGHT SAVING TIME

After setting or modifying the date, display will show:

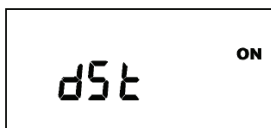

- For standard USA daylight savings (DSt), press **MODE** and go to step 5.0.
- For dates other than standard USA dates, press **MONTH** and go to step 4.1.
- If daylight saving time (DSt) is NOT required, press **DEL** display will show:

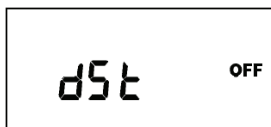

Press **ENTER** then go to step 5.0.

4.1 TO MODIFY STANDARD USA DAYLIGHT SAVINGS DATES

NOTE: The first two digits represent the month and the second set of digits represent the week in the month. Choices for week are 01 (1st), 02 (2nd), 03 (3rd) or L (Last) week of the month. The default day

is Sunday (SU.) Once modified date set, the unit will automatically calculate the correct start dates in the future.

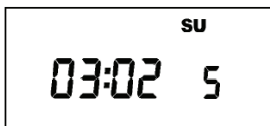

Now press **MONTH** and **DATE** buttons to modify the starting DST settings. Pressing **DAY** changes default day. EXAMPLE: A screen showing "04:01 SU S" represents April (04), the first week (01), Sunday (SU), and the Start (S) of daylight savings time.

Press **ENTER** to save and the display will show:

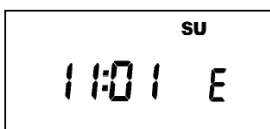

Now press **MONTH** and **DATE** buttons to modify the ending DST settings. Pressing **DAY** changes default day. EXAMPLE: A screen showing "10: L SU E" represents October (10), the Last week (L), Sunday (SU), and the End (E) of daylight savings time.

Press **ENTER** to save and the display will show the modified DSt starting date.

Press **MODE** twice to go to step 5.0.

5.0 DUTY CYCLE AND SIGNAL

The Duty Cycle programming mode begins with a display that shows the ON duration first for Duty Cycle 1 and the OFF duration second. Programming both ON and OFF will enable the load to repeatedly turn ON then OFF.

The Signal Timer operation can be used by setting only the ON duration of each duty cycle. Skip the OFF duration entry. The load will turn ON for the duration of the ON period, and it will not be repeated.

Once you've selected a cycle time, you need to program the schedule in Section 6.0. Schedule the events whenever you need to start and end the duty cycle or to execute a signal, such as school bells.

If not needed, press the **MODE** key

5.1 TO SET DUTY CYCLE AND SIGNAL

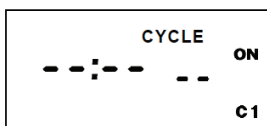

Press either **HOUR**, **MIN**, or **SEC** keys to set the desired ON duration for the cycle (ON C1).

Press the **ENTER** key.

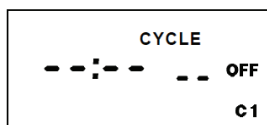

- a) For signal timer application, press the **ENTER** key.
- b) For a cycle program, press the **HOUR**, **MIN**, or **SEC** keys to set the time to the desired OFF duration for the cycle (OFF C1). Press the **ENTER** key.

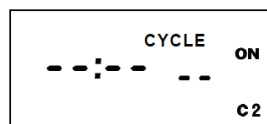

Follow the same procedures above to set the second signal or duty cycle entries.

Press **MODE** key to advance to next screen.

6.0 SCHEDULE SET MODE

Press **MODE** key until display shows:

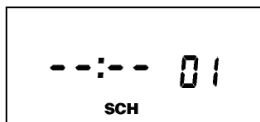

6.1 SETTING HOURS AND MINUTES

Note: A schedule is needed for each event. If a typical ON/OFF pair is required, use SCH 01 for the ON event and SCH 02 for the OFF event.

Press the **HOUR**, and **MIN** keys to set the desired time.
Press **EVENT** to set desired event
(ON or OFF, C1, or C2)

Note: C1 or C2 will not be displayed if the duty cycle durations are not set in Step 5.

Press **CH SELECT** key to select channel on DG280A.

Press **ENTER** to save.

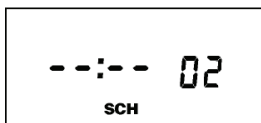

Follow the same procedures above to set more schedule entries.

Press **MODE** when schedules are complete.

7.0 SKIP DAY MODE

The Skip Day programming allows events to be repeated for a certain number of days, and then skipped for a number of days. Both active and skip periods are set by the user from 1 to 31 days. The timer will follow the programmed 24 hour schedule during each day of the active period.

Example: A generator may have an active schedule for 1 day and then skip 29 days to allow operation once a month for testing purposes. On the one active day, a 10 minute schedule may be programmed to start at 4:00am.

The two channels of the DG280A add additional programming capabilities in the Skip Day mode. Alternating days of operation may be set for each channel. This lets one load be active while the second load is skipped.

Example: Two pumps are used to operate at alternate times to extend the life of each pump. An active schedule may be set so Pump A operates 5 days and skip 2 days. Pump B can be set to be active on 2 days and skip the other 5. Care must be taken in programming if the two pumps must not operate at the same time.

If not needed, press the **MODE** key

7.1 SETTING SKIP DAY MODE

Review the Skip Day carefully before using this feature.

Call the Tork Tech Support line if you have any question on set-up 888-500-4598.

Press **MODE** until display shows:

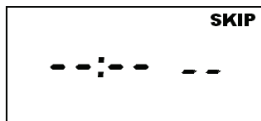

Press **D/ON** button to set the number of days load will be active. The first number pair will change.

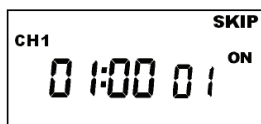

Press **D/OFF** button to set the number of days load will skip. The second number pair will change.

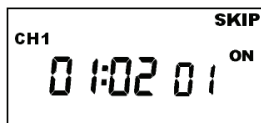

Press **DAY** button to set today's position within the **D/ON** and **D/OFF** pattern. The third number pair will change.

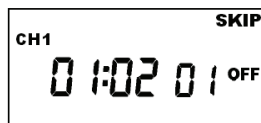

Example 1: The screen below shows a pattern with 3 active days and 2 skip days with today set as the first day of skip (01 OFF).

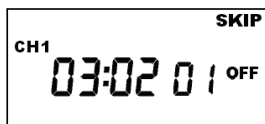

Example 2: For the DG280A with opposite operations, screen below shows channel 2 set for a cycle with 2 active days and 3 skip days with today set as the first active day (01 ON) to be opposite the first example.

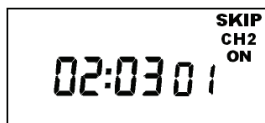

Press **MODE** when Skip Days are complete.

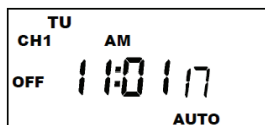

Unit is in the **AUTO** (automatic) mode.

The word **FLASH** may appear to indicate a new program has been written to memory.

Press the **EVENT** key once (or twice for two circuit units) to activate current schedule then **EVENT** key again to return to AUTO mode.

8.0 REVIEW, MODIFY AND DELETE

Press **MODE** to advance to any of the following MODES:

1. **AUTO MODE:** In this automatic mode, the unit will execute the scheduled programs. Time, day, seconds and load status are displayed. C1 or C2 is displayed when Duty Cycle is programmed and operating.

OVERRIDE IN AUTO MODE: The load status of the channel can be manually changed by pressing the **OVRD** key (or **OVR1** and **OVR2** key for DG280A). The unit will stay in this position until the next scheduled event. A flashing LCD load indication (ON, OFF) shows the status was changed by the override not a scheduled event.

Press the **OVRD** (or **OVR1** and **OVR2** key for DG280A) key until ON or OFF stops flashing to return to programmed setting.

OVERRIDE IN MAN MODE: The load status of the channel can be manually changed by pressing the **OVRD** key (or **OVR1** and **OVR2** key for DG280A). The unit will stay in this position until **OVRD** is pressed again. A flashing LCD load indication (ON, OFF) shows the status was changed by the override not a scheduled event.

3. **CLK MODE:** To change the current time press **HOUR** and **MIN** to modify existing settings. Press **ENTER** to save changes.

4. **DATE MODE:** Press **MONTH, DATE** and **YEAR** to modify existing settings. Press **ENTER** to save changes. DAY is automatically adjusted.

5. **DS+ MODE:** Factory default is set at US standard daylight savings dates noted by ON. To remove daylight savings time setting from, press **DEL** to change

screen to show OFF. DST may be activated again by pressing **DEL**. Press **ENTER** to save changes. To change the from the standard DST month/week/day setting press **HOUR** and refer to step 4.1.

6. **CYCLE MODE**: To change duty cycle timing, press either the **HOUR, MIN, or SEC** keys. Press **ENTER** to save changes.

7. **SCH MODE**: To change schedule, press **ENTER** to advance to desired event. Press **HOUR, MIN, EVENT** to modify time settings. Press **DEL** to delete. Press **ENTER** after each modification to save changes.

8. **SKIP MODE**: Press **D/ON, D/OFF** and **DAY** to modify existing settings. Press **ENTER** to save changes.

NOTES:

1. Unit has a look back feature. Press the **EVENT** key once (or twice for two circuit units) to activate current schedule then **EVENT** key again to return to the time (run) screen. Unit will automatically pick up the last schedule.

2. To clear date and time only and provide unit with a soft reboot, press and release the reset button that is recessed under the small hole to right side of LCD screen.

3. To clear all memory, while in the **RUN** mode, press **ENTER**, display will show:

Use the **EVENT** key to display:





Now press **ENTER** briefly and everything in the timer memory is wiped off including real time, date and 12HOUR will flash.

4. A "PF" on the display indicates a Power Failure and the unit requires AC power to operate. The time and date are protected for 7 days by the super cap. The program is retained in permanent memory.

5. A "Lo" on the display indicates that the super cap has run low and the unit needs to be powered with AC. A minimum of 8 hours is required to fully charge the super cap.

6. All programs and cycles will end at 1200 a.m. on the start of a skip day.

7. The CH1 symbol (or CH2 symbol on a two channel) will flash when in skip day/s. No operations will occur on channel with flashing symbol.

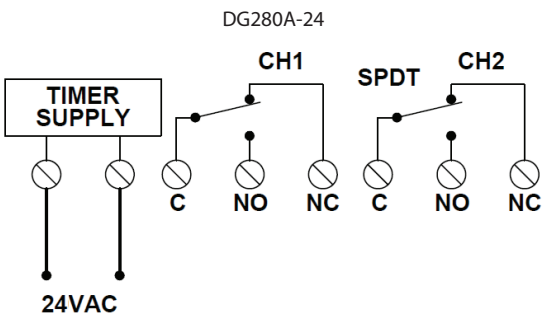
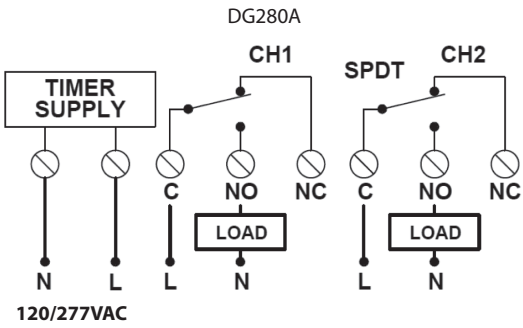
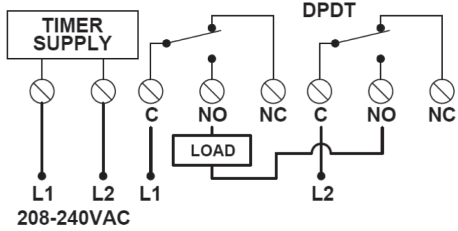
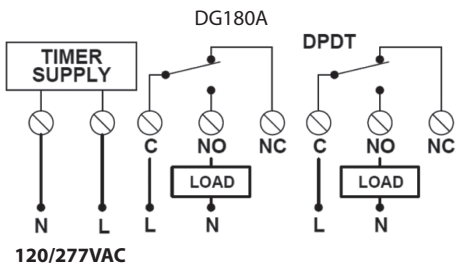

Cycle Times			
#	ON	OFF	Description
C1	:	:	
C2	:	:	

Cycle Days			
#	ON	OFF	Description
Ch.1			
Ch.2			

TORK®

A DIVISION OF **NSI** NSI INDUSTRIES, LLC
USA • 800.321.5847 • www.nsiindustries.com