

INDUSTRIAL DURABLE & VANDAL-RESISTANT HAND DRYERS

TECHNICAL data sheet

INDUSTRIAL DURABLE & VANDAL-RESISTANT HAND DRYERS

Industry standard hand dryers with the longest motor life of all hand dryers in the market. Low sound level. Durable and vandal resistant porcelain enamel finishes won't break, dent or scratch. Automatic or push-button operation. Stationary nozzle can be adjusted to swivel on push button models. 1GVL6 & 1GVL7 are recess mounted units and ADA compliant.



3NXE8, 6H009

3NXE7, 5W630, 5W631, 5W632, 5W633



1GVL7

1GVL6



PRODUCT FEATURES AND BENEFITS

- Automatic or push-button operation
- Surface or recess mounted with ADA compliance
- Longest life of all dryers
- Low sound level
- Durable and vandal resistant
- Classic style design

DESIGN FEATURES

DRYER

- Automatic unit - Activated by infrared sensor, automatic drying cycle.
- Push-button unit - Activated by electro-mechanical timer with 25 Amp switch and 30 second cycle.
- Incorporates a 2100 (optional 1500) watt Nichrome wire heating element Protected by an automatic-resetting, thermal cutoff
- Provides a 70°F temperature rise
- IPX1 ingress protection

MOTOR

- Thermally-protected, universal brush-type motor operating at 7,500 RPM
- Delivering 200 CFM air flow at a velocity of 7,300 LFM

MATERIALS

- Cover material: Cast Iron with porcelain enamel finish. Optional 14GA polished or brushed finish #304S.S. or epoxy enamel finish C.R. Steel.
- The wall-mounted base is constructed of die-cast aluminum
- The nozzle is constructed of die-cast zinc alloy finished in bright chrome

PRODUCT SPECIFICATIONS

	115 V	208 - 230 V
Amps	20	10
Watts	2300	2300
Hz	60	60

DRYER DIMENSIONS:

Unit Size (HxWxD) - 9.5" x 11.3" x 8.3"
 Unit Weight - Cast Iron 27.3 lbs, Steel 15.8 lbs
 Shipping Size (HxWxD) - 12.5" x 14.4" x 10.1"
 Shipping Weight - Cast Iron 29.8 lbs, Steel 18 lbs

PRODUCT DIMENSION DRAWINGS

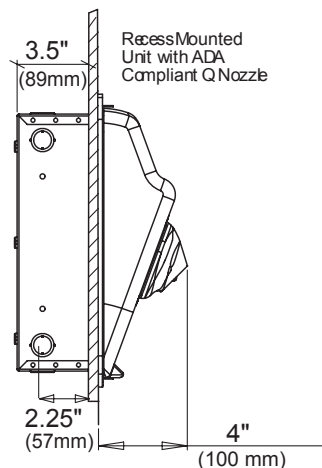
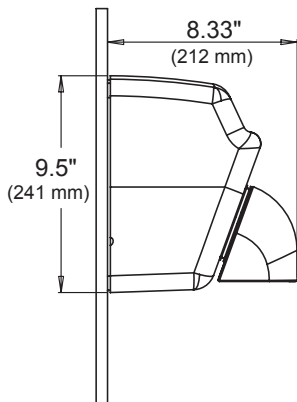
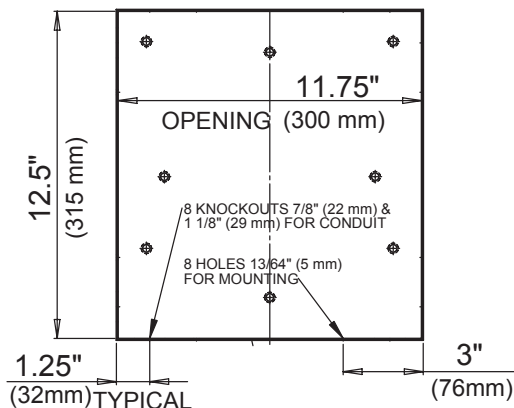
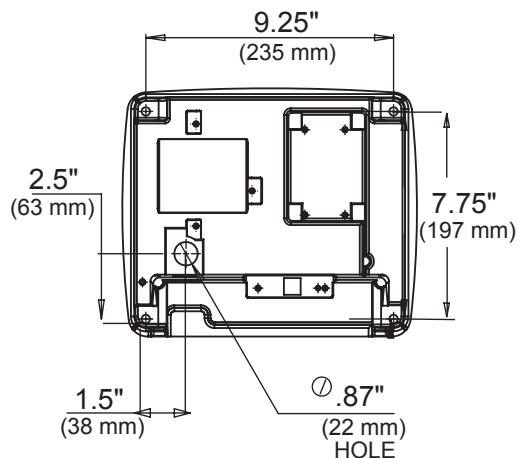

CERTIFICATION APPROVED



IPX1



SKU NO. NOZZLE TYPE COVER MATERIAL COVER FINISH OPERATION VOLTAGE AMPS DRY TIME

DAYTON INDUSTRIAL DURABLE & VANDAL-RESISTANT HAND DRYER							
3NXE7	Fixed	Steel	Epoxy Enamel	Push Button	120 V	20	30 sec.
5W630	Swivel	Cast Iron	Porcelain Enamel	Push Button	120 V	20	30 sec.
5W631	Swivel	Cast Iron	Porcelain Enamel	Push Button	208/230 V	9/10	30 sec.
5W632	Fixed	Cast Iron	Porcelain Enamel	Push Button	120 V	20	30 sec.
5W633	Fixed	Cast Iron	Porcelain Enamel	Push Button	208/230 V	9/10	30 sec.
3NXE8	Fixed	Steel	Epoxy Enamel	Automatic	120 V	20	30 sec.
6H009	Fixed	Cast Iron	Porcelain Enamel	Automatic	120 V	20	30 sec.
1GVL6	Fixed	Cast Iron	Porcelain Enamel	Push Button	120 V	20	30 sec.
1GVL7	Fixed	Cast Iron	Porcelain Enamel	Automatic	120 V	20	30 sec.

Find it at Grainger.

Call or visit your local branch or go to grainger.com/dayton for complete product line information.

