

MODEL	PHS21AJD01	PHS23AJD01	PHS24AJD02	PHS25AJD02	PHS27AJD03	PHS28AJD06	PHS2AAJD08
ACTUATOR	AP10DA	AP10DA	AP20DA	AP20DA	AP30DA	AP73DA	AP148DA
SIZE	1/4 NPT	1/2 NPT	3/4 NPT	1 NPT	1 1/2 NPT	2 NPT	3 NPT
A	1.97	2.95	3.15	3.54	4.72	5.51	7.56
B	1.32	1.38	1.78	2.01	2.95	3.77	5.50
C	0.45	0.59	0.79	0.98	1.50	2.00	3.14
D	1.31	1.38	1.63	1.75	2.17	2.62	4.02
E	4.81	4.88	5.45	5.57	6.54	7.57	10.47
F	4.65	4.65	5.26	5.26	5.53	7.20	8.77
G	2.61	2.61	2.82	2.82	3.23	3.90	4.72
H	3.50	3.50	3.82	3.82	4.37	4.95	6.45
MAX. Δ PSI	500 CWP	500 CWP	500 CWP	500 CWP	300 CWP	300 CWP	300 CWP
WT. LBS	1.55	1.77	3.36	3.83	7.23	12.51	34.38

VALVE DATA

BODY/END CAP	ASTM A351 GR. CF8M (316 SS)
STEM	316 STAINLESS STEEL
BALL	316 STAINLESS STEEL
SEATS	RTFE (CARBON)
THRUSTWASHER	PTFE
STEM SEAL	PTFE / VITON O-RING

UNCONTROLLED DRAWING

THIS PRINT IS THE PROPERTY OF DYNAQUIP CONTROLS AND SHALL NOT BE COPIED, REPRODUCED, LOANED, OR DISPOSED OF DIRECTLY OR INDIRECTLY, NOR USED FOR ANY PURPOSE OTHER THAN THAT FOR WHICH IT IS SPECIFICALLY FURNISHED EXCEPT BY WRITTEN PERMISSION OF DYNAQUIP CONTROLS.

NO. VHS2 SERIES FILE NO. SUB119.1

TITLE
BALL VALVE
316 SS - FULL PORT - NPT
AP-DA ACTUATOR

DR	DATE	CH'KD	DATE	ENGR	DATE
FBA	06-30-05	LJH	09-15-04	LJH	09-15-04



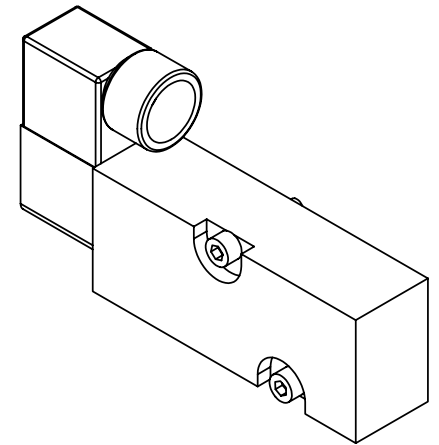
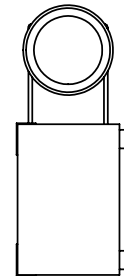
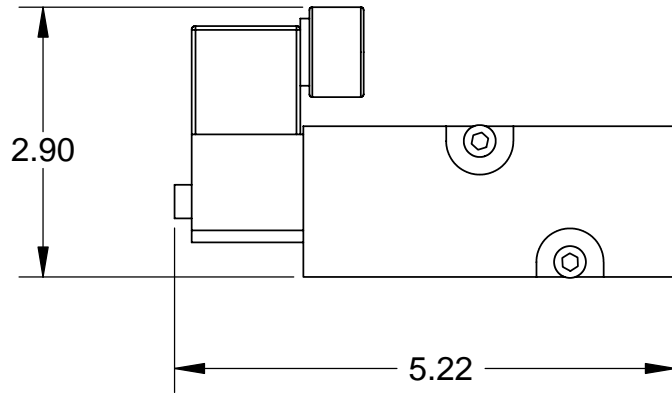
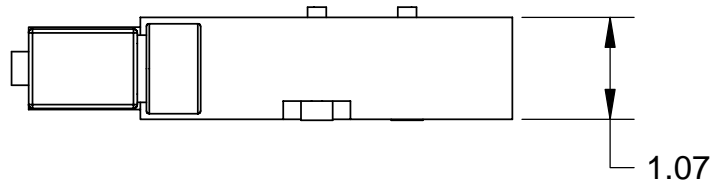

145750



**SOLENOID SPECIFICATIONS; 4-WAY VALVE, CONDUIT ENTRY,
12" WIRE LEADS, NEMA 4**

145750.04	12 VDC
145750.03	24 VDC
145750.02	24 VAC
145750.01	115 VAC
PART NO.	VOLTAGE

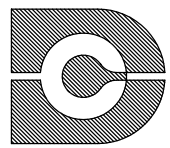
MATERIAL						
FINISH						
UNLESS OTHERWISE SPECIFIED: ALL MACHINED SURFACES TO HAVE 125 RMS FINISH BREAK ALL CORNERS .005/.010 X 45° INTERNAL CORNER RADII .010 MAX. R.	LET	ECO	DATE	LET	ECO	DATE
	UNLESS OTHERWISE SPECIFIED ALL DIMENSIONS ARE IN INCHES. TOLERANCES ARE: X +/- .100 .XX +/- .015 FRACTIONS +/- .015					

NO. 145750		FILE NO.	DO NOT SCALE
SOLENOID VALVE			
DR LJH	DATE 06-05-06	CHKD LJH	DATE 06-05-06
ENGR LJH	DATE 06-05-06		
			

DynaQuip®



AP Series Pneumatic Actuator Manual

Version 2.a

DynaQuip Pneumatic Actuator Engineering Manual

The actuator is designed for pneumatic operation with maximum air pressure of 150 PSIG (10.34 bar) and a temperature range of -10° to +195° F. The use of filtered and lubricated air is recommended.

WARNING

DO NOT APPLY ELECTRIC OR PNEUMATIC POWER UNLESS UNIT IS FULLY ASSEMBLED AND MOUNTED.

ALWAYS DISCONNECT ELECTRICAL AND PNEUMATIC POWER SOURCES AND RELIEVE PRESSURE IN THE SYSTEM BEFORE WORKING ON THIS UNIT.

IT IS RECOMMENDED THAT EYE PROTECTION BE WORN WHILE SERVICING THE SYSTEM.

FAILURE TO COMPLY WITH ABOVE WARNINGS COULD RESULT IN PERSONAL INJURY AND/OR DAMAGE TO THE UNIT.

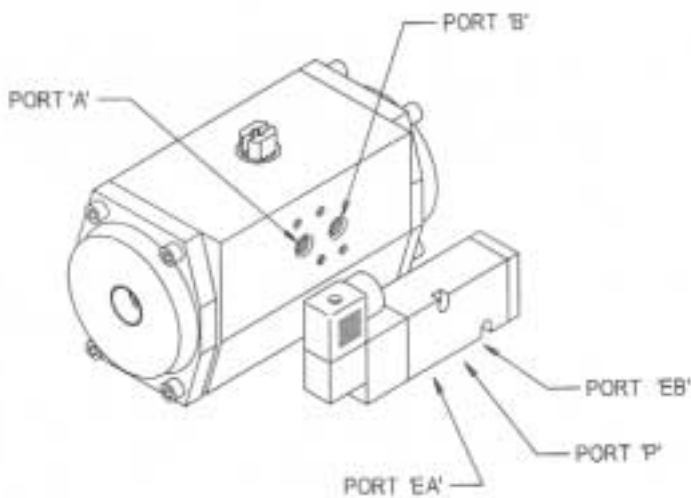

MOUNT SOLENOID IN POSITION SHOWN. USE THE TWO MOUNTING HOLES NOTED TO ALIGN O-RINGS AND SOLENOID TO THE ACTUATOR

Operation

Pressurizing port "A" will cause a counter-clockwise rotation of the shaft and position indicator. For double acting models, a clock-wise rotation is obtained by pressurizing port "B" and venting port "A". For spring return models, a clockwise rotation is obtained by removing supply air and venting port "A" only.

ACTUATORS EQUIPPED WITH DYNAQUIP SOLENOID VALVES

Double Acting (Normally Closed Mounting)

Air is supplied to the 1/4" NPT port on the solenoid. When electric power is applied to the solenoid, air is allowed to enter the center chamber of the actuator, driving the pistons outward, causing a counterclockwise rotation of the shaft. Air in the end chambers is vented to atmosphere. The actuator is in the open position.

When electric power is removed from the solenoid, supply air is shifted to the end chambers, driving the pistons inward, causing a clockwise rotation of the shaft. Air in the center chamber is vented to atmosphere. The actuator is in the closed position.

Spring Return (Fail-Safe Closed Mounting)

Air is supplied to the 1/4" NPT port on the solenoid. When electric power is applied to the solenoid, air is allowed to enter the center chamber of the actuator, driving the pistons outward, compressing the springs in the end chambers and causing a counter-clockwise rotation of the shaft. Air in the end chambers is vented to atmosphere. The actuator is in the open position.

When electric power is removed from the solenoid, supply air is blocked and air in the center chamber is vented to atmosphere. The compressed springs in the end chambers extend, driving the pistons inward, causing a clockwise rotation of the shaft. The valve is in the closed position.

Fail-Safe Features

When electrical failure occurs and the air supply is not interrupted, the solenoid on the double acting model will cycle the actuator to the closed position.

Spring return model actuator will cycle to the closed position in the event of electrical and/or air supply failure.

Valve being actuated can be mounted to the actuator in such a way that the valve can either fail-safe open or fail-safe closed.

Manual Override

In the event of air pressure failure, the DynaQuip actuator may be cycled manually. This is done by removing the position indicator and applying a wrench to the exposed end of the shaft and turning it in the desired direction. For manual operation, the air must be allowed to escape from the actuator. This may require disconnecting air lines at the actuator or solenoid inlet port.

Vérification de cycle

Une routine de vérification de cycle peut être exécutée sur les actionneurs équipés de solénoïde fournis par DynaQuip, en actionnant le bouton de dérivation sur le corps du solénoïde.

Entretien

Sous des conditions nommales d'utilisation, les actionneurs

pneumatiques DynaQuip ne nécessitent aucun programme d'entretien spécifique. Une inspection régulièrement prévue doit être exécutée pour vérifier:

- L'alignement de l'actionneur et de la soupape
- Le logement ou des ferrures de montages endommagés.
- Des pièces usées, desserrées ou décalées par suite de choc, vibrabons, etc.

Voir la page 8 pour le dépannage.

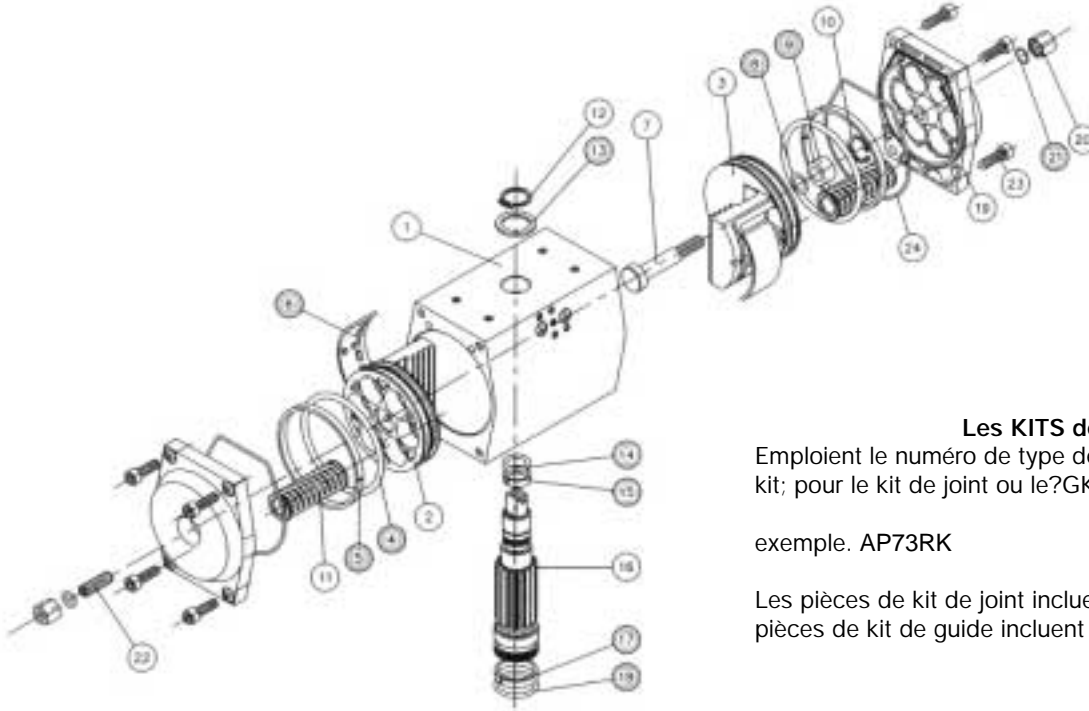

Les KITS de RÉPARATION

Emploient le numéro de type de déclencheur suivi d'un code de kit; pour le kit de joint ou le?GK? pour le kit de guide. par

exemple. AP73RK

Les pièces de kit de joint incluent les numéros 4, 14, 18. Les pièces de kit de guide incluent les numéros 5, 6, 13, 15, 17.

Article	Quantité	Description	Matériel
1	1	Corps	Aluminium Anodisé
2	1	Piston STD	Fonte d'aluminium De Matrice
3	1	Piston DSL	Fonte d'aluminium De Matrice
4	2	Bague De Piston	Buna N
5	2	Guide De Piston	Delrin 500
6	1	Patin De Piston	Delrin 500
7	1	DLS	Acier inoxydable de la Norme ANSI 304
8	1	Bague de DLS	Viton®
9	1	Roulement de DLS	Teflon
10	1	Anneau ressort de DLS	Acier inoxydable de la Norme ANSI 304
11	Max 12	Cartouche De Ressort	Acero Revestido De epoxy
12	1	Anneau ressort	Acier d'ENP ASTM B656
13	1	Rondelle De Pignon	Delrin 500
14	1	Bague Supérieure De Pignon	Buna N
15	1	Roulement Supérieur De Pignon	Delrin 500
16	1	Pignon	Acier d'ENP ASTM B656
17	1	Abaissez Le Roulement De Pignon	Delrin 500
18	1	Abaissez La Bague De Pignon	Buna N
19	2	Monture d'embout	Aluminium Enduit Époxyde
20	2	Écrous De Cachetage	Acier inoxydable de la Norme ANSI 304
21	2	Bague D'Écrou De Cachetage	Buna N
22	1	Arrêt Ouvert De Voyage	Acier inoxydable de la Norme ANSI 304
23	8	Attaches De Monture D'embout	Acier inoxydable de la Norme ANSI 304
24	2	Bague De Monture D'embout	Buna N

Manuel d'ingénierie de l'actionneur Pneumatique DynaQuip

L'actionneur est conçu pour un fonctionnement pneumatique avec une pression d'air maximum de 1034 kPa à la jauge (10.34 bar) dans une gamme de température allant de -20° à +80°C. L'usage d'air filtré lubrifié est recommandé.

AVERTISSEMENT

NE PAS METTRE SOUS TENSION OU SOUS FORCE PNEUMATIQUE SAUF SI L'UNITÉ EST COMPLÈTEMENT ASSEMBLÉE ET MONTÉE.

TOUJOURS DÉCONNECTER LES SOURCES ÉLECTRIQUE ET PNEUMATIQUE ET DÉGAGER LA PRESSIION DU SYSTÈME AVANT DE TRAVAILLER SUR CETTE UNITÉ.

IL EST RECOMMANDÉ DE PORTER UNE PROTECTION DES YEUX PENDANT LE SERVICE DU SYSTÈME

NÉGLIGER DE SUIVRE CES AVERTISSEMENTS PEUT CAUSER DES BLESSURES CORPORELLES ET/OU

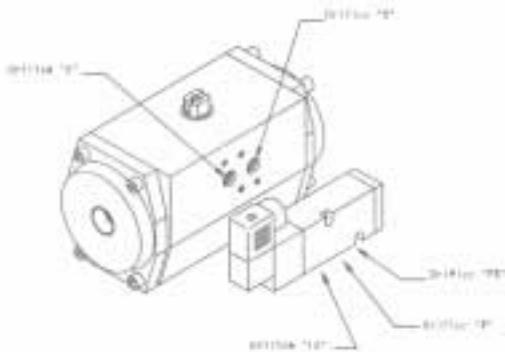

ENDOMMAGER L'UNITÉ.

MONTER LE SOLÉNOÏDE DANS LA POSITION MONTRÉE. SE SERVIR DES DEUX TROUS DE MONTAGE INDICQUÉS POUR ALIGNER LES JOINTS TORIQUES ET LE SOLÉNOÏDE AVEC L'ACTIONNEUR.

Fonctionnement

La mise sous pression de l'orifice "A" cause la rotation de l'arbre et de l'indicateur de position dans le sens inverse des aiguilles d'une montre. Pour les modèles à double action, la rotation dans le sens des aiguilles d'une montre est obtenue en mettant la pression à l'orifice "B" et en ventilant l'orifice "A". Pour les modèles à retour à ressort, la rotation dans le sens des aiguilles d'une montre est obtenue en retirant l'alimentation d'air et en ventilant l'orifice "A" seulement.

Actionneurs équipés de soupapes à solénoïde DynaQuip

Double Action (MONTAGE NORMALEMENT FERMÉ)

L'air arrive à l'orifice de 1/4 NPT sur le solénoïde. Quand le solénoïde est mis sous tension, l'air peut entrer dans la chambre centrale de l'actionneur, poussant les pistons à sortir et causant la rotation de l'arbre dans le sens inverse des aiguilles d'une montre. L'air dans les chambres de sortie se dégage dans l'atmosphère. L'actionneur est en position ouverte. Quand le solénoïde est mis hors tension, l'alimentation d'air est envoyée dans les chambres de sortie, attirant les pistons vers l'intérieur et causant la rotation de l'arbre dans le sens des aiguilles d'une montre. L'air dans la chambre centrale se dégage dans l'atmosphère. L'actionneur est en position fermée.

Retour par ressort (MONTAGE FERMÉ À SÉCURITÉ INTÉGRÉE)

L'air arrive à l'orifice de 1/4 NPT sur le solénoïde. Quand le solénoïde est mis sous tension, l'air peut entrer dans la chambre centrale de l'actionneur, poussant les pistons à sortir, appuyant les ressorts dans les chambres de sortie et causant la rotation de l'arbre dans le sens inverse des aiguilles d'une montre. L'air dans les chambres de sortie se dégage dans l'atmosphère. L'actionneur est en position ouverte.

Quand la solénoïde est mis hors tension, l'alimentation d'air est bloquée et l'air dans la chambre centrale se dégage dans l'atmosphère. Les ressorts compressés dans les chambres de sortie se détendent attirant les pistons vers l'intérieur et causant la rotation de l'arbre dans le sens des aiguilles d'une montre. La soupape est en position fermée.

Caractéristiques de la sécurité intégrée

Quand une panne électrique se produit et que l'alimentation d'air n'est pas interrompue, le solénoïde du modèle à double action cycle la soupape en position fermée

L'actionneur de modèle à retour par ressort cycle en position fermée dans le cas d'une panne électrique et/ou d'alimentation d'air

La soupape actionnée peut être montée sur l'actionneur de telle façon que la sécurité intégrée de la soupape peut être en position ouverte ou en position fermée.

Dérivation manuelle

Dans le cas d'une panne de pression d'air, l'actionneur DynaQuip peut être cyclé manuellement. Ceci se fait en retirant l'indicateur de position et en serrant une clé à molette sur la partie exposée de l'arbre et en tournant dans la direction désirée. Pour une opération manuelle, l'air doit être relâché de l'actionneur. Ceci peut nécessiter le débranchement des conduites d'air à l'actionneur ou à l'orifice d'entrée du solénoïde.

Cycle Check

A routine cycle check can be performed on actuators equipped with DynaQuip supplied solenoids, by activating the override button on the solenoid body.

Maintenance

Under normal operation, DynaQuip pneumatic actuators require no formal maintenance program. Regularly scheduled inspections should be performed to check:

- Actuator-to-valve alignment
- Damaged housing or mounting hardware
- Worn, loose or shifted parts due to shock, vibration etc.

See page 8 for Troubleshooting.

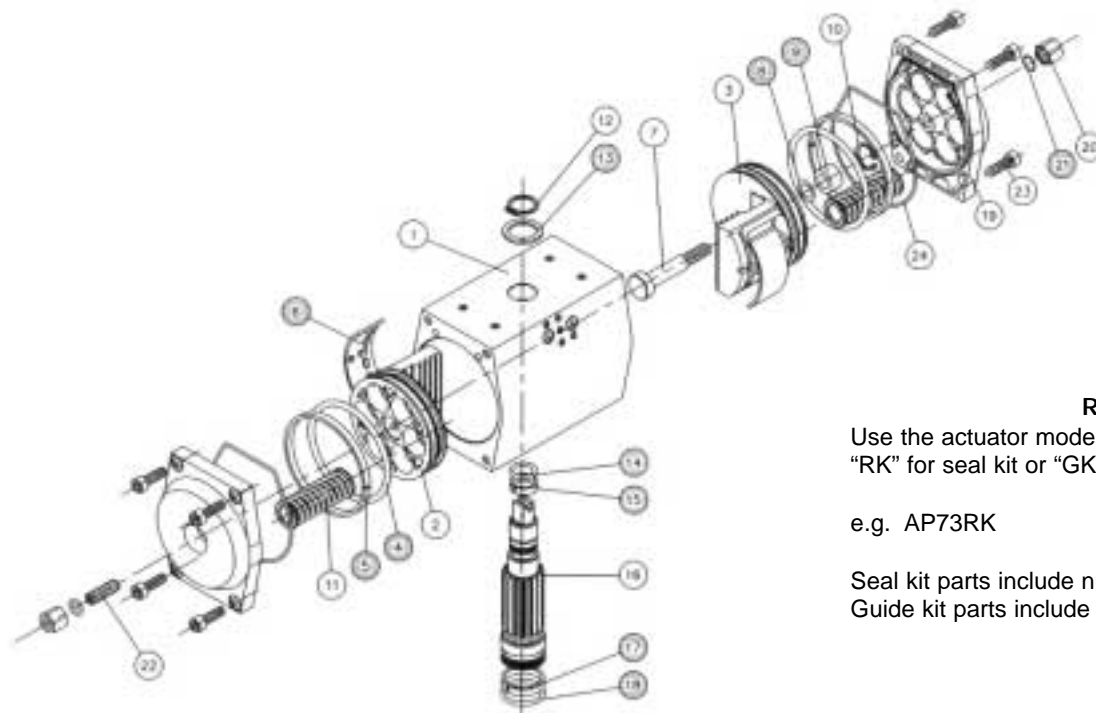

REPAIR KITS

Use the actuator model number followed by a kit code; "RK" for seal kit or "GK" for guide kit.

e.g. AP73RK

Seal kit parts include numbers 4, 14, 18.

Guide kit parts include numbers 5, 6, 13, 15, 17.

Item #	Qty	Description	Material
1	1	Body	Anodized Aluminum
2	1	Piston STD	Die Cast Aluminum
3	1	Piston DLS	Die Cast Aluminum
4	2	Piston O-Ring	Buna N
5	2	Piston Guide	Delrin 500
6	1	Piston Skate	Delrin 500
7	1	DLS	ANSI 304 Stainless Steel
8	1	DLS O-Ring	Viton®
9	1	DLS Bearing	Teflon
10	1	DLS Snap Ring	ANSI 304 Stainless Steel
11	Max 12	Spring Cartridge	Epoxy Coated Steel
12	1	Snap Ring	E.N.P. ASTM B656 Steel
13	1	Pinion Washer	Delrin 500
14	1	Upper Pinion O-Ring	Buna N
15	1	Upper Pinion Bearing	Delrin 500
16	1	Pinion	E.N.P. ASTM B656 Steel
17	1	Lower Pinion Bearing	Delrin 500
18	1	Lower Pinion O-Ring	Buna N
19	2	End Cap	Epoxy Coated Aluminum
20	2	Sealing Nuts	ANSI 304 Stainless Steel
21	2	Seal Nut O-Ring	Buna N
22	1	Open Travel Stop	ANSI 304 Stainless Steel
23	8	End Cap Fasteners	ANSI 304 Stainless Steel
24	2	End Cap O-Ring	Buna N

Revisión del Ciclo

Se puede hacer una revisión del ciclo de rutina en accionadores que vienen con solenoides proporcionados por DynaQuip, si se activa el botón del dispositivo de transferencia de mando en el cuerpo del solenoide.

Mantenimiento

En el caso de la operación normal, los accionadores neumáticos DynaQuip no necesitan de un programa formal de mantenimiento. Se deben hacer inspecciones programadas para revisar lo siguiente:

- Alineamiento del accionador a la válvula
- Caja o artrículos de montaje de ferretería dañados
- Partes despastadas, sueltas o que se han movido al debido al choque, la vibración, etc

Vea la página 8 para localizar averías.

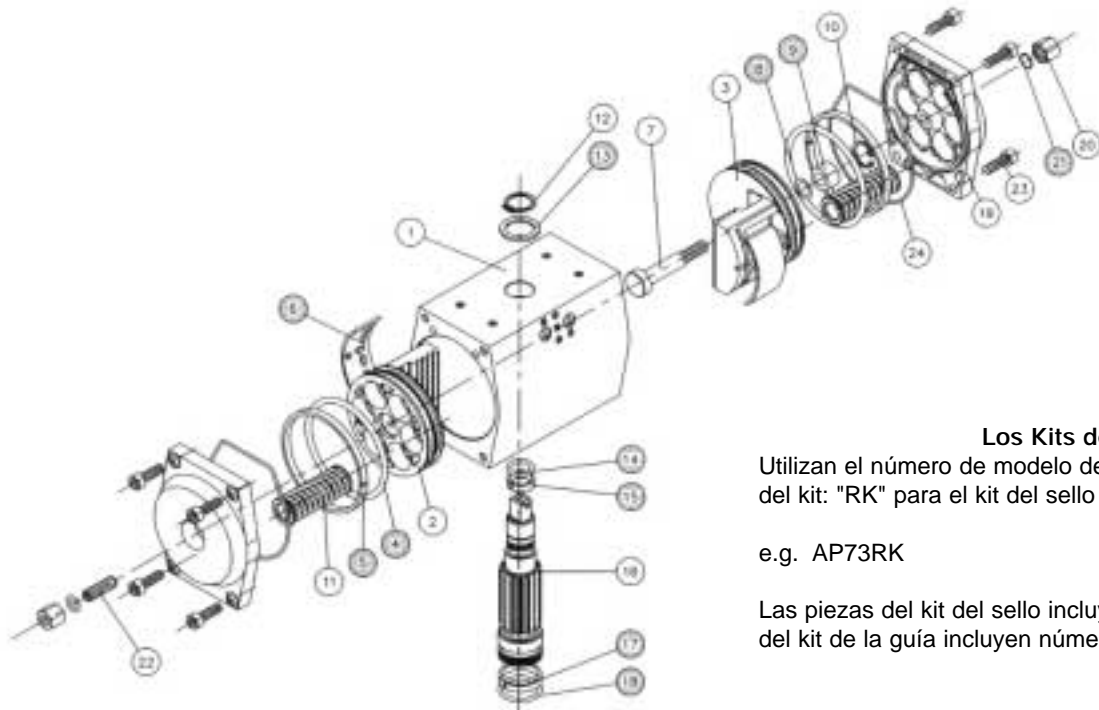

Los Kits de Reparación

Utilizan el número de modelo del actuador seguido por un código del kit: "RK" para el kit del sello o "GK" para el kit de la guía.

e.g. AP73RK

Las piezas del kit del sello incluyen números 4,14,18. Las piezas del kit de la guía incluyen números 5, 6, 13, 15, 17.

Artículo	Qty	Descripción	Material
1	1	Cuerpo	Aluminio Anodizado
2	1	Pistón Std	Aluminio De Molde Del Dado
3	1	Pistón Dsl	Aluminio De Molde Del Dado
4	2	Anillo o Del Pistón	Buna N
5	2	Guía Del Pistón	Delrin 500
6	1	Patín Del Pistón	Delrin 500
7	1	DLS	Acero Inoxidable del ANSI 304
8	1	Anillo o de DLS	Viton®
9	1	Cojinete de DSL	Teflon
10	1	Anillo Rápido de DLS	Acero Inoxidable del ANSI 304
11	Max 12	Cartucho Del Resorte	Acero Revestido De epoxy
12	1	Anillo Rápido	Acero de ENP ASTM B656
13	1	Arandela Del Piñón	Delrin 500
14	1	Anillo o Superior Del Piñón	Buna N
15	1	Cojinete Superior Del Piñón	Delrin 500
16	1	Piñón	Acero de ENP ASTM B656
17	1	Baje El Cojinete Del Piñón	Delrin 500
18	1	Baje El Anillo o Del Piñón	Buna N
19	2	Casquillo de extremo	Aluminio Revestido De epoxy
20	2	Tuercas De Lacre	Acero Inoxidable del ANSI 304
21	2	Anillo o De la Tuerca De Lacre	Buna N
22	1	Parada Abierta Del Recorrido	Acero Inoxidable del ANSI 304
23	8	Sujetadores Del Casquillo De Extremo	Acero Inoxidable del ANSI 304
24	2	Anillo o Del Casquillo De Extremo	Buna N

Trouble Shooting		
SYMPTOM	POSSIBLE PROBLEM	POSSIBLE SOLUTION
Actuator does not respond to control signal	Power interruption (electric)	Check supply power for proper voltage
	Power interruption (air)	Check air supply pressure
Actuator will not fully open and/or close the valve	Travel limit set improperly	Set internal and/or external stops
	Valve torque too high	Check valve for blockage or other malfunction. Check to assure proper sizing of actuator to valve torque
Erratic operation	Over heating due to excessive cycle rate	Rapid and continuous cycling will cause heat build-up and seal failure. Reduce cycle rate.
Actuator operates but valve does not turn	Broken linkage	Check linkage between actuator and valve
	Broken valve stem	Check valve stem

Identificacion de Problemas		
SINTOMA	POSIBLE PROBLEMA	POSIBLE SOLUCION
El accionador no responde a la señal de control	Interrupción de energía (eléctrica)	Revise el abastecimiento de energía para verificar si el voltaje está correcto
	Interrupción de energía (aire)	Revise la presión del abastecimiento de aire
El accionador no se abre completamente ni/o derra la válvula	El límite del recorrido está ajustado incorrectamente	Ajuste el tope interno y/o externo
	La torsión de la válvula es muy alta	Revise la válvula para verificar si está bloqueada o si tiene otro aspecto funcionando mal Revise para verificar si el tamaño del accionador con respecto a la torsión de la válvula está correcto
Operación errática	Sobrecalentamiento debido a una velocidad de ciclo excesiva	El ciclo rápido y continuo producirá una acumulación de calor y falla del sello. Reduzca la vabcidad.
El accionador opera, pero la válvula no gira	Articulación quebrada	Revise la arbulación entre el acdonador y la válvula
	Vástago de la válvula quebrado	Reviselo

Dépannage		
SYMPTOME	CAUSE POSSIBLE	SOLUTION POSSIBLE
L'actionneur ne répond pas au signal de commande	Coupure de courant électrique	Vérifier que le voltage de l'alimentation électrique est correct
	Intemruption d'arrivée d'air	Vérifier la pression de l'arrivée d'air
L'actionneur n'ouvre/ne ferme pas complètement la soupape	Limite de course mal réglée	Régler les butées internes ou externes
	Couplage de la soupape trop élevé	Vérifier la soupape pour blocage ou autre mauvais fonctionnement Vérifier pour assurer que le calibrage de rachonneur est correct pour le couplage de la soupape
Fonctionnement irrégulier	Surchauffe due à un taux de cycle excessif	Des cycles rapides et continus cause une accumulation de chaleur et la-défaillance du joint. Réduire le taux de cyclage.
Le moteur de l'actionneur fonctionne, mais la soupape ne tourne pas	Liaison rompue	Vérifier la liaison entre l'actionneur et la soupape
	Queue de soupape cassée	Vérifier la queue de la soupape

NO. AP10

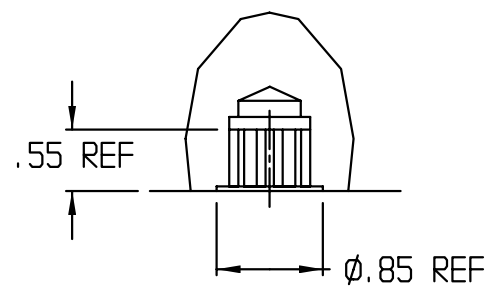

CLEARANCE DEPTH
DETAIL 3

10-32 X .31 DEEP
TYP. 4 PLACES

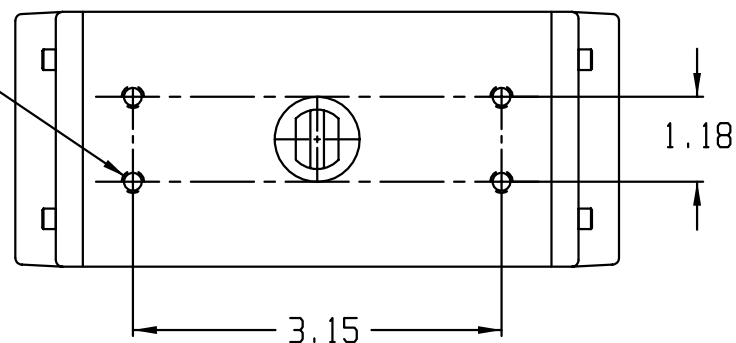

MODEL NUMBER PER
CHART BELOW

TORQUE SPEC. PER
CHART BELOW

DynaQuip Pneumatic Actuator

MODEL

TORQUE (80 psi) in-lbs

MAX. PRESSURE - 150 PSI. CAUTION: BEFORE DISASSEMBLY REFER TO MAINTENANCE INSTRUCTIONS WITH SPECIAL REFERENCE TO SAFETY NOTES.

800-545-3636

www.dynaquip.com

MADE IN ITALY

PORT CONNECTION
DETAIL 1

.39 ACROSS
FLATS

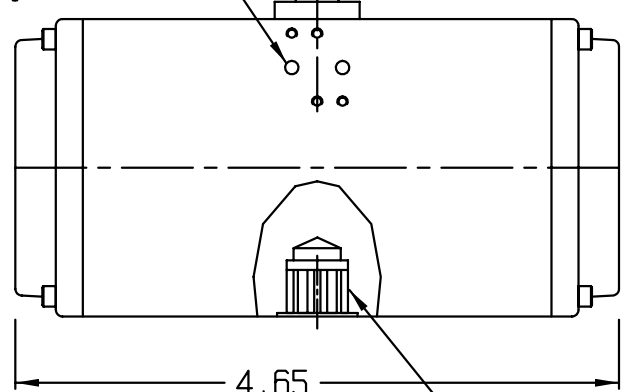

SEE
DETAIL 3

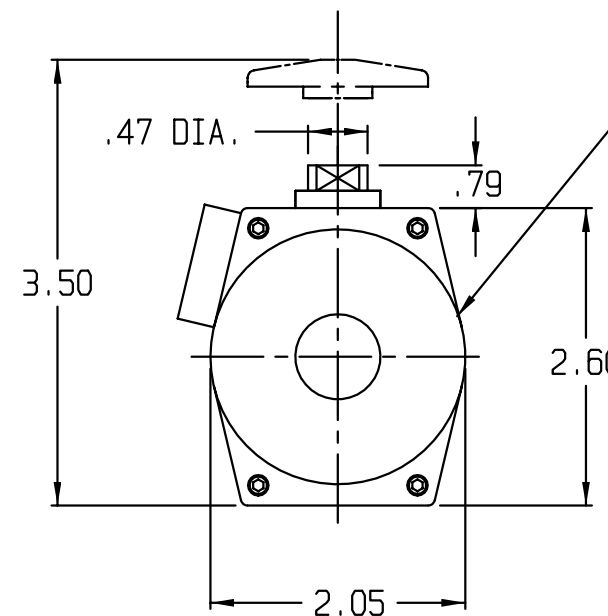

PLACE LABEL 145812
THIS SIDE

DynaQuip Control's
PURCHASE ORDER NUMBER

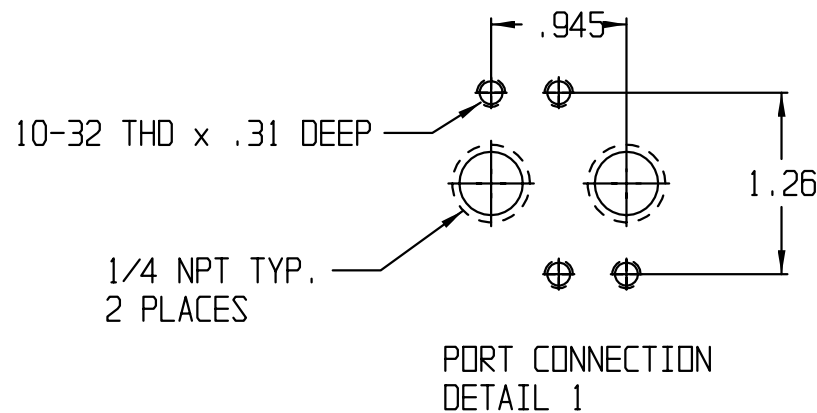

PORT CONNECTION
DETAIL 1

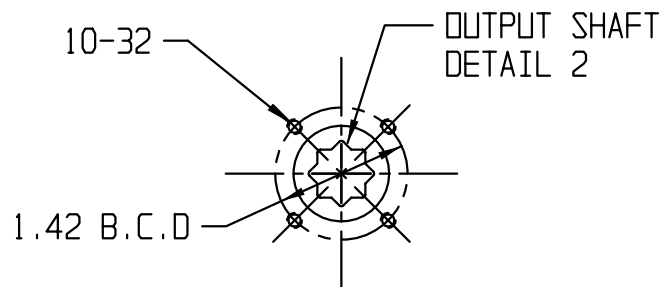

BOTTOM CONNECTION

OUTPUT SHAFT
DETAIL 2

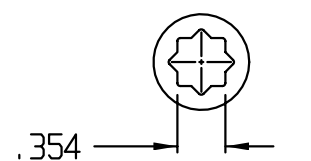

OUTPUT SHAFT
DETAIL 2

MATERIAL SPECIFICATIONS

- BODY.....ALUMINUM
POLYESTER EPOXY COATED
- PISTON.....POLYRILAMIDE
- END CAP.....POLYRILAMIDE
- SEAL, O-RINGS.....BUNA N
- BEARINGS.....DELTRIN 500
- SCREWS.....304 STAINLESS STEEL
- NUTS.....304 STAINLESS STEEL

PRESSURE: 20psig TO 150psig MAX.
TEMPERATURE: FROM -10°F TO +195°F
LUBRICATION: FACTORY LUBRICATED FOR THE
LIFE OF THE ACTUATOR UNDER
NORMAL WORKING CONDITIONS.

AP10SR3	40/57	SPRING RETURN (3 / END)
AP10SR2	60/38	SPRING RETURN (2 / END)
AP10DA	100	DOUBLE ACTING
MODEL NO.	TORQUE (In-Lbs • 80 PSI) (AIR / SPRING)	DESCRIPTION

MATERIAL		NO. AP10		FILE NO.	DO NOT SCALE
FINISH ANODIZE / EPOXY COATED		TITLE PNEUMATIC ACTUATOR			
UNLESS OTHERWISE SPECIFIED: ALL MACHINED SURFACES TO HAVE 125 RMS FINISH BREAK ALL CORNERS .005/.010 X 45° INTERNAL CORNER RADII .010 MAX. R.		DR SSD	DATE 06-19-03	CH'KD LJH	DATE 07-16-03
UNLESS OTHERWISE SPECIFIED ALL DIMENSIONS ARE IN INCHES. TOLERANCES ARE: ANGLES +/- 2 DEG. .X +/- .100 FRACTIONS +/- .015 .XX +/- .015 .XXX +/- .005		LET ECO	DATE	LET ECO	DATE
THIS PRINT IS THE PROPERTY OF DYNAQUIP CONTROLS AND SHALL NOT BE COPIED, REPRODUCED, LOANED, OR DISPOSED OF DIRECTLY OR INDIRECTLY, NOR USED FOR ANY PURPOSE OTHER THAN THAT FOR WHICH IT IS SPECIFICALLY FURNISHED EXCEPT BY WRITTEN PERMISSION OF DYNAQUIP CONTROLS.					

NO. AP14

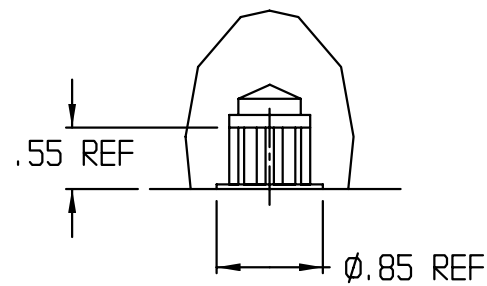

CLEARANCE DEPTH
DETAIL 3

10-32 X .31 DEEP
TYP. 4 PLACES

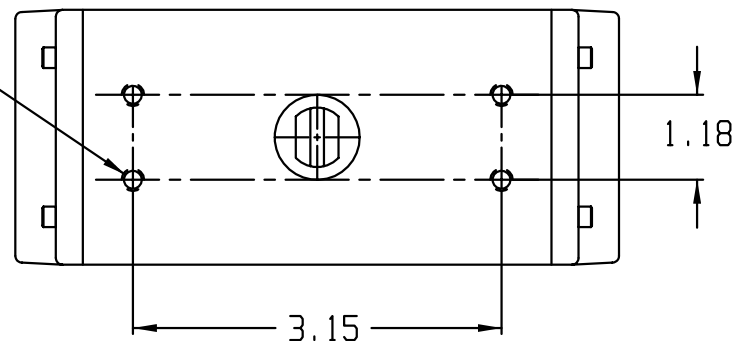

PORT CONNECTION
DETAIL 1

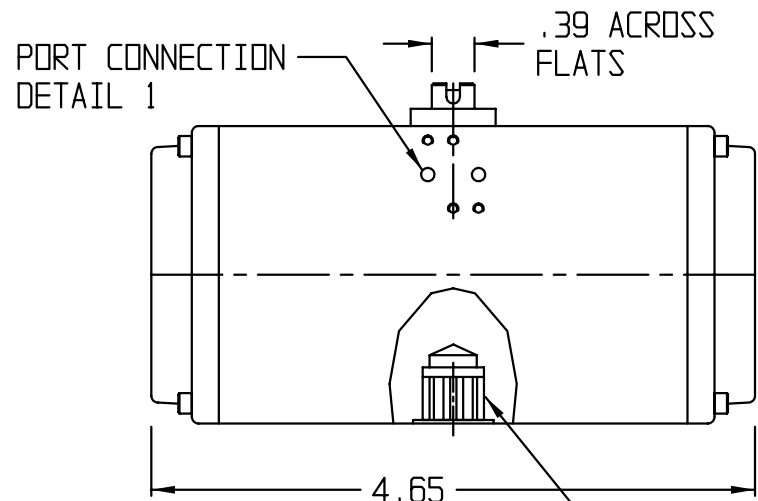

SEE
DETAIL 3

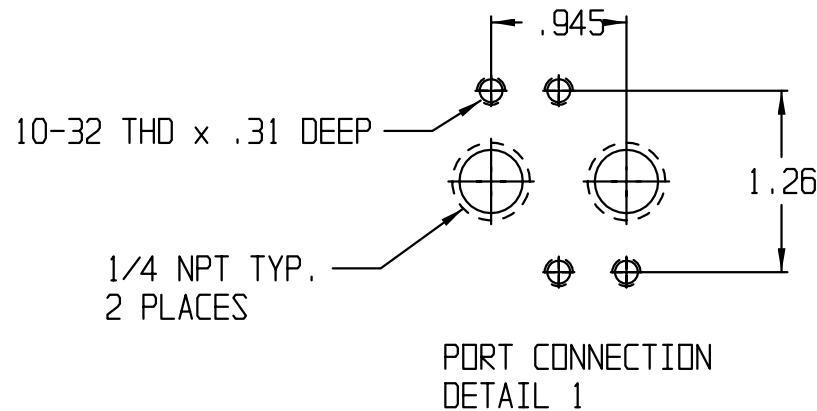

PORT CONNECTION
DETAIL 1

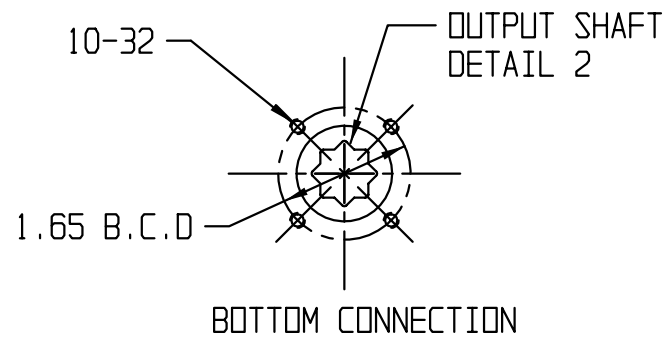

BOTTOM CONNECTION

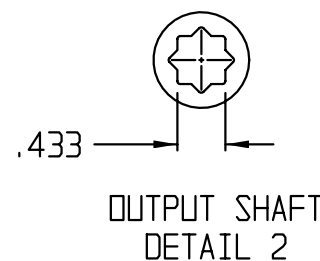

OUTPUT SHAFT
DETAIL 2

MODEL NUMBER PER
CHART BELOW

TORQUE SPEC. PER
CHART BELOW

DynaQuip Pneumatic Actuator

MODEL

TORQUE (80 psi) in-lbs

MAX. PRESSURE - 150 PSI. CAUTION: BEFORE DISASSEMBLY REFER TO MAINTENANCE INSTRUCTIONS WITH SPECIAL REFERENCE TO SAFETY NOTES.

800-545-3636

www.dynaquip.com

MADE IN ITALY

PLACE LABEL 145812
THIS SIDE

DynaQuip Control's
PURCHASE ORDER NUMBER

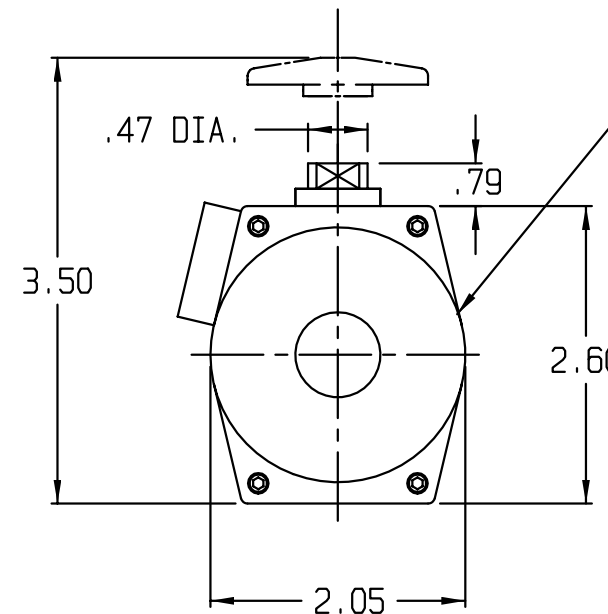

MATERIAL SPECIFICATIONS

- BODY.....ALUMINUM
- POLYESTER EPOXY COATED
- PISTON.....POLYRILAMIDE
- END CAP.....POLYRILAMIDE
- SEAL, O-RINGS.....BUNA N
- BEARINGS.....DELTRIN 500
- SCREWS.....304 STAINLESS STEEL
- NUTS.....304 STAINLESS STEEL

PRESSURE: 20psig TO 150psig MAX.
TEMPERATURE: FROM -10°F TO +195°F
LUBRICATION: FACTORY LUBRICATED FOR THE LIFE OF THE ACTUATOR UNDER NORMAL WORKING CONDITIONS.

AP14SR3	40/57	SPRING RETURN (3 / END)
AP14SR2	60/38	SPRING RETURN (2 / END)
AP14DA	100	DOUBLE ACTING
MODEL NO.	TORQUE (In-Lbs • 80 PSI) (AIR / SPRING)	DESCRIPTION

MATERIAL						NO. AP14		FILE NO.	DO NOT SCALE		
FINISH ANODIZE / EPOXY COATED						TITLE PNEUMATIC ACTUATOR					
UNLESS OTHERWISE SPECIFIED: ALL MACHINED SURFACES TO HAVE 125 RMS FINISH BREAK ALL CORNERS .005/.010 X 45° INTERNAL CORNER RADII .010 MAX. R.						DR L J H	DATE 01-09-04	CH'KD L J H	DATE 01-09-04	ENGR L J H	DATE 01-09-04
UNLESS OTHERWISE SPECIFIED ALL DIMENSIONS ARE IN INCHES. TOLERANCES ARE: ANGLES +/- 2 DEG. .X +/- .100 FRACTIONS +/- .015 .XX +/- .015 .XXX +/- .005						LET E C O	DATE	LET E C O	DATE	THIS PRINT IS THE PROPERTY OF DYNAQUIP CONTROLS AND SHALL NOT BE COPIED, REPRODUCED, LOANED, OR DISPOSED OF DIRECTLY OR INDIRECTLY, NOR USED FOR ANY PURPOSE OTHER THAN THAT FOR WHICH IT IS SPECIFICALLY FURNISHED EXCEPT BY WRITTEN PERMISSION OF DYNAQUIP CONTROLS.	



NO. AP20

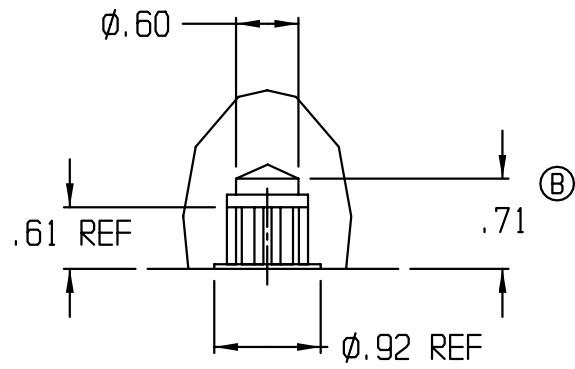

CLEARANCE DEPTH
DETAIL 3

10-32 x .31 DEEP
TYP. 4 PLACES

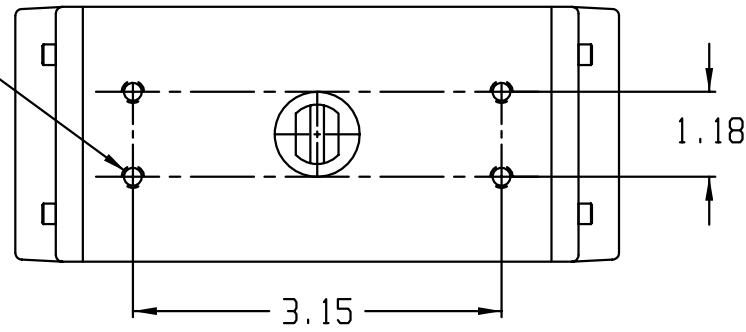

PORT CONNECTION
DETAIL 1

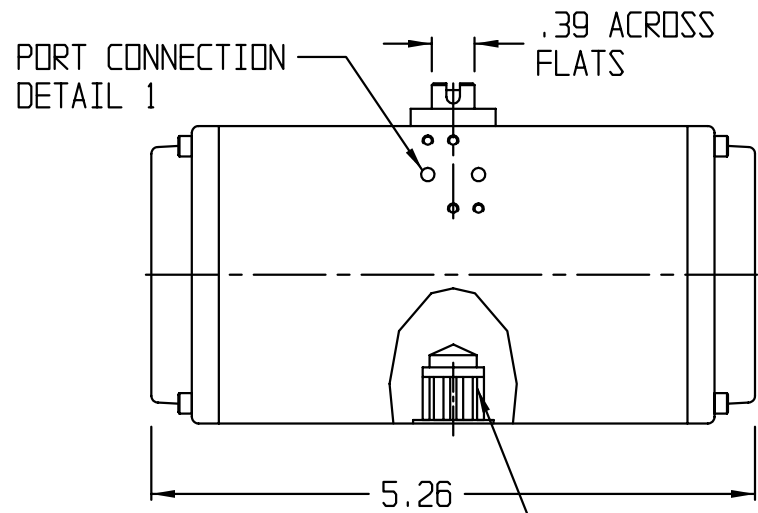

OUTPUT SHAFT
DETAIL 2

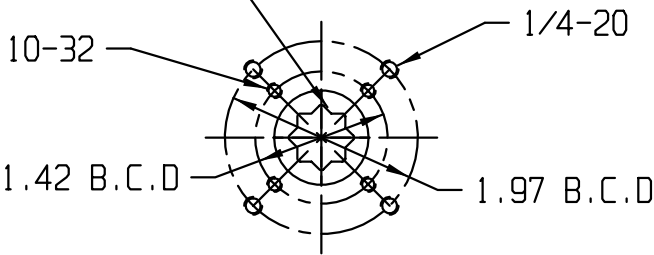

BOTTOM CONNECTION

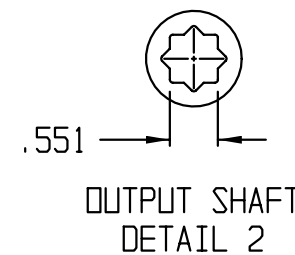

OUTPUT SHAFT
DETAIL 2

MODEL NUMBER PER
CHART BELOW

TORQUE SPEC. PER
CHART BELOW

DynaQuip Pneumatic Actuator

MODEL

TORQUE (80 psi) in-lbs

MAX. PRESSURE - 150 PSI. CAUTION: BEFORE DISASSEMBLY REFER TO MAINTENANCE INSTRUCTIONS WITH SPECIAL REFERENCE TO SAFETY NOTES.

800-545-3636

www.dynaquip.com

MADE IN ITALY

PLACE LABEL 145812
THIS SIDE

DynaQuip Control's
PURCHASE ORDER NUMBER

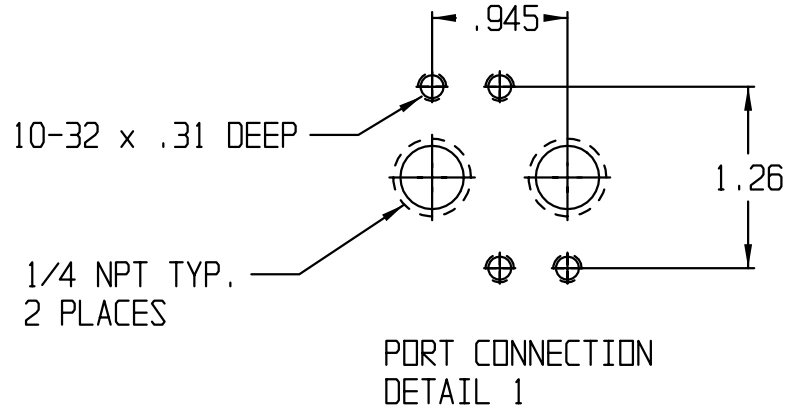
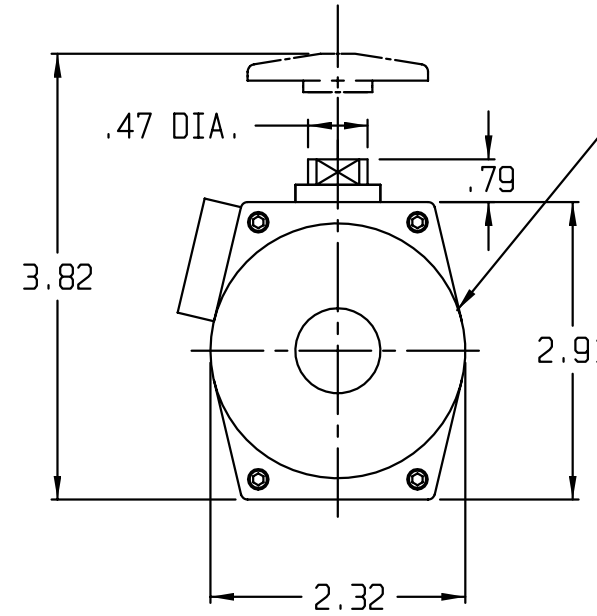

PORT CONNECTION
DETAIL 1

MATERIAL SPECIFICATIONS

- BODY.....ALUMINUM
- PISTON.....POLYESTER EPOXY COATED
- END CAP.....POLYRILAMIDE
- SEAL, O-RINGS.....POLYRILAMIDE
- BEARINGS.....BUNA N
- SCREWS.....DELTRIN 500
- NUTS.....304 STAINLESS STEEL

PRESSURE: 20psig TO 150psig MAX.
TEMPERATURE: FROM -10°F TO +195°F
LUBRICATION: FACTORY LUBRICATED FOR THE LIFE OF THE ACTUATOR UNDER NORMAL WORKING CONDITIONS.

AP20SR6	81/114	SPRING RETURN (6 / END)
AP20SR5	102/95	SPRING RETURN (5 / END)
AP20SR4	122/76	SPRING RETURN (4 / END)
AP20SR3	142/57	SPRING RETURN (3 / END)
AP20SR2	162/38	SPRING RETURN (2 / END)
AP20DA	203	DOUBLE ACTING
MODEL NO.	TORQUE (In-Lbs • 80 PSI) (AIR / SPRING)	DESCRIPTION

MATERIAL						NO. AP20		FILE NO.	DO NOT SCALE
FINISH ANODIZE / EPOXY COATED						TITLE PNEUMATIC ACTUATOR			
UNLESS OTHERWISE SPECIFIED: ALL MACHINED SURFACES TO HAVE 125 RMS FINISH BREAK ALL CORNERS .005/.010 X 45° INTERNAL CORNER RADII .010 MAX. R.						B	A366	02-12-04	DR SSD
UNLESS OTHERWISE SPECIFIED ALL DIMENSIONS ARE IN INCHES. TOLERANCES ARE: ANGLES +/- 2 DEG. .X +/- .100 FRACTIONS +/- .015 .XX +/- .015 .XXX +/- .005						A	A262	07-16-03	DATE 06-20-03
THIS PRINT IS THE PROPERTY OF DYNAQUIP CONTROLS AND SHALL NOT BE COPIED, REPRODUCED, LOANED, OR DISPOSED OF DIRECTLY OR INDIRECTLY, NOR USED FOR ANY PURPOSE OTHER THAN THAT FOR WHICH IT IS SPECIFICALLY FURNISHED EXCEPT BY WRITTEN PERMISSION OF DYNAQUIP CONTROLS.						LET ECO	DATE	LET ECO	DATE
						LJH	07-16-03	LJH	07-16-03



NO. AP30

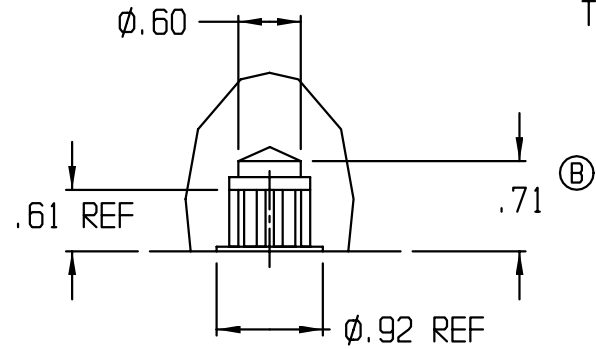

CLEARANCE DEPTH
DETAIL 3

10-32 X .31 DEEP
TYP. 4 PLACES

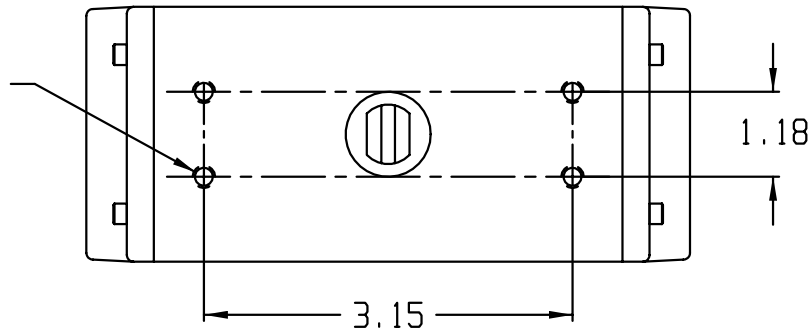

PORT CONNECTION
DETAIL 1

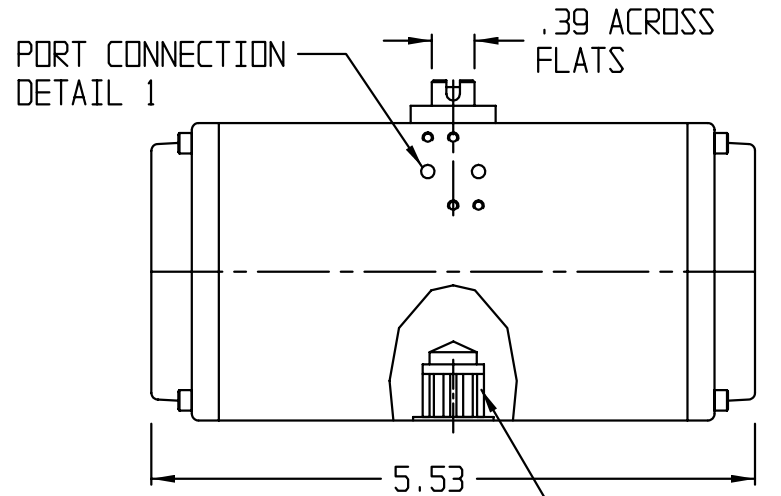

SEE
DETAIL 3

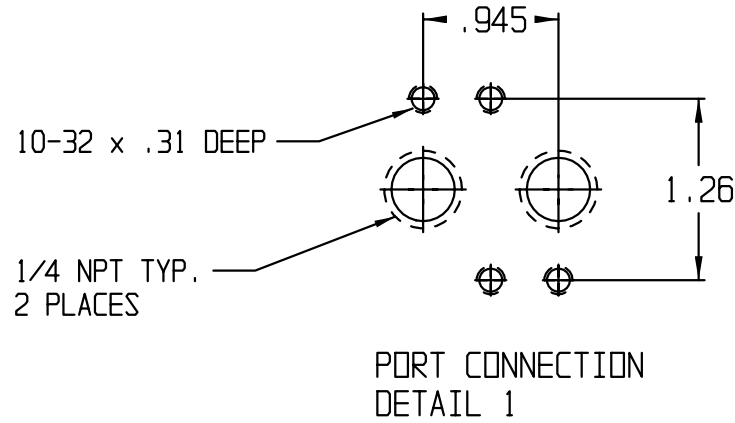

PORT CONNECTION
DETAIL 1

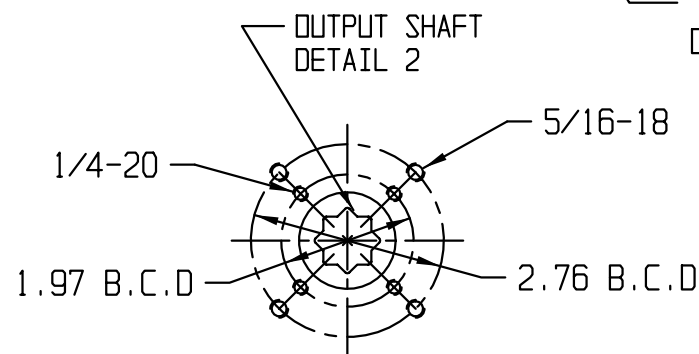

BOTTOM CONNECTION

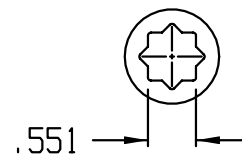

OUTPUT SHAFT
DETAIL 2

MODEL NUMBER PER
CHART BELOW

TORQUE SPEC. PER
CHART BELOW

DynaQuip Pneumatic Actuator

MODEL

TORQUE (80 psi) in-lbs

MAX. PRESSURE - 150 PSI. CAUTION: BEFORE DISASSEMBLY REFER TO MAINTENANCE INSTRUCTIONS WITH SPECIAL REFERENCE TO SAFETY NOTES.

800-545-3636
www.dynaquip.com

MADE IN ITALY

PLACE LABEL 145812
THIS SIDE

DynaQuip Control's
PURCHASE ORDER NUMBER

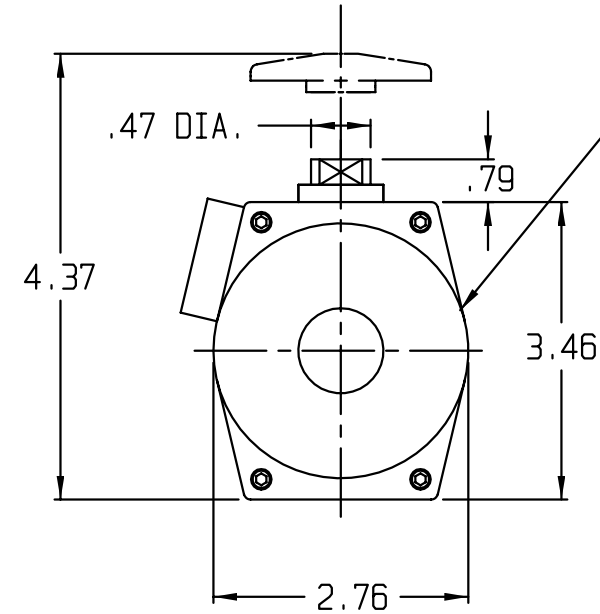

MATERIAL SPECIFICATIONS

- BODY.....ALUMINUM
POLYESTER EPOXY COATED
- PISTON.....ALUMINUM ALLOY
- END CAP.....ALUMINUM ALLOY
EPOXY COATED
- SEAL, ORINGS.....BUNA N
- BEARINGS.....DELRIN 500
- SCREWS.....304 STAINLESS STEEL
- NUTS.....304 STAINLESS STEEL.

PRESSURE: 20psig TO 150psig MAX.
TEMPERATURE: FROM -10°F TO +195°F
LUBRICATION: FACTORY LUBRICATED FOR THE LIFE OF THE ACTUATOR UNDER NORMAL WORKING CONDITIONS.

AP30SR6	131/167	SPRING RETURN (6 / END)
AP30SR5	159/139	SPRING RETURN (5 / END)
AP30SR4	187/111	SPRING RETURN (4 / END)
AP30SR3	215/83	SPRING RETURN (3 / END)
AP30SR2	242/56	SPRING RETURN (2 / END)
AP30DA	302	DOUBLE ACTING
MODEL NO.	TORQUE (In-Lbs • 80 PSI) (AIR / SPRING)	DESCRIPTION

MATERIAL						NO. AP30		FILE NO.	DO NOT SCALE
FINISH ANODIZE / EPOXY COATED						TITLE PNEUMATIC ACTUATOR			
UNLESS OTHERWISE SPECIFIED: ALL MACHINED SURFACES TO HAVE 125 RMS FINISH BREAK ALL CORNERS .005/.010 X 45° INTERNAL CORNER RADII .010 MAX. R.						B	A366	02-12-04	DR SSD
UNLESS OTHERWISE SPECIFIED ALL DIMENSIONS ARE IN INCHES. TOLERANCES ARE: ANGLES +/- 2 DEG. .X +/- .100 FRACTIONS +/- .015 .XX +/- .015 .XXX +/- .005						A	A262	07-16-03	DATE 06-20-03
THIS PRINT IS THE PROPERTY OF DYNAQUIP CONTROLS AND SHALL NOT BE COPIED, REPRODUCED, LOANED, OR DISPOSED OF DIRECTLY OR INDIRECTLY, NOR USED FOR ANY PURPOSE OTHER THAN THAT FOR WHICH IT IS SPECIFICALLY FURNISHED EXCEPT BY WRITTEN PERMISSION OF DYNAQUIP CONTROLS.						LET ECO	DATE	LET ECO	DATE
									CH'KD LJJ
									DATE 07-16-03
									ENGR LJJ
									DATE 07-16-03



NO. AP34

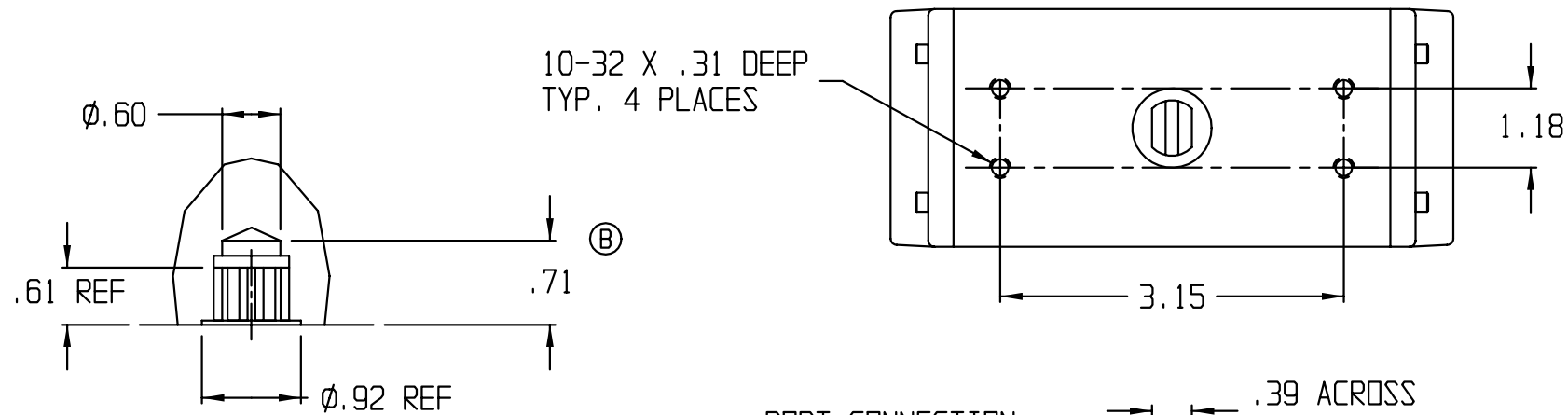

CLEARANCE DEPTH
DETAIL 3

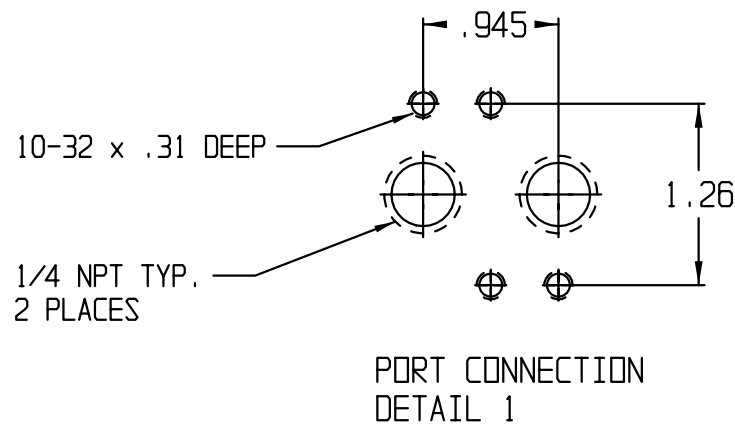

PORT CONNECTION
DETAIL 1

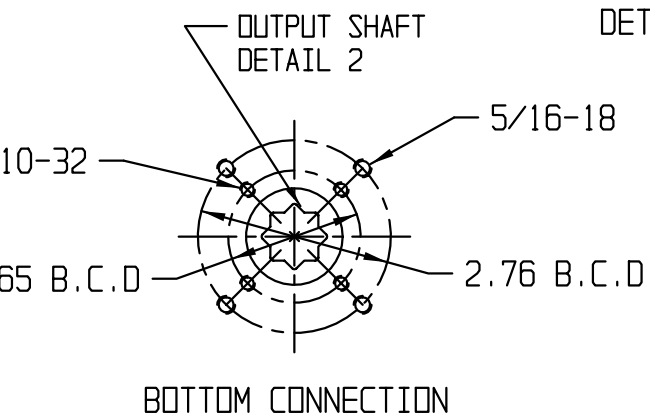
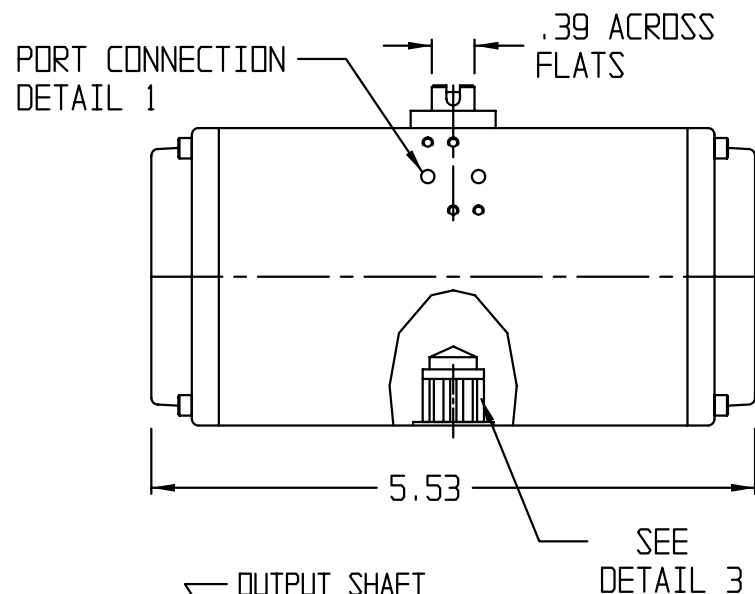

BOTTOM CONNECTION

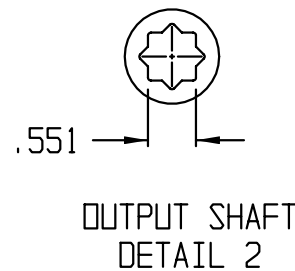

OUTPUT SHAFT
DETAIL 2

MODEL NUMBER PER
CHART BELOW

TORQUE SPEC. PER
CHART BELOW

DynaQuip Pneumatic Actuator

MODEL

TORQUE (80 psi) in-lbs

MAX. PRESSURE - 150 PSI. CAUTION: BEFORE DISASSEMBLY REFER TO MAINTENANCE INSTRUCTIONS WITH SPECIAL REFERENCE TO SAFETY NOTES.

800-545-3636
www.dynaquip.com

MADE IN ITALY

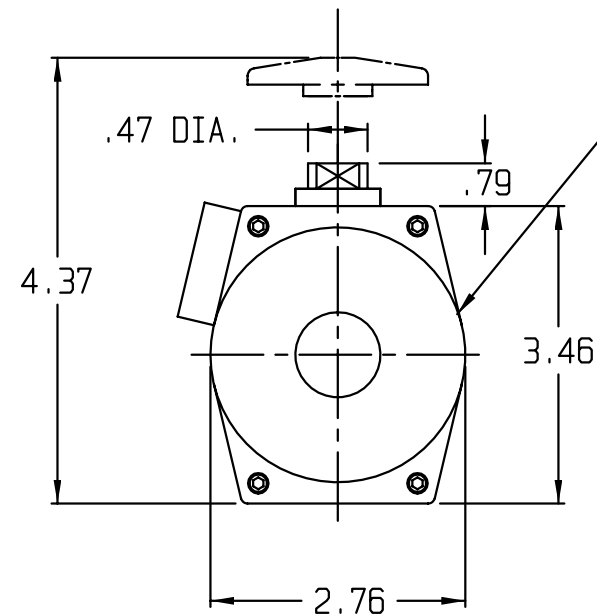

PLACE LABEL 145812
THIS SIDE

DynaQuip Control's
PURCHASE ORDER NUMBER

MATERIAL SPECIFICATIONS

- BODY.....ALUMINUM
POLYESTER EPOXY COATED
- PISTON.....ALUMINUM ALLOY
- END CAP.....ALUMINUM ALLOY
EPOXY COATED
- SEAL, O-RINGS.....BUNA N
- BEARINGS.....DELRIN 500
- SCREWS.....304 STAINLESS STEEL
- NUTS.....304 STAINLESS STEEL.

PRESSURE: 20psig TO 150psig MAX.
TEMPERATURE: FROM -10°F TO +195°F
LUBRICATION: FACTORY LUBRICATED FOR THE LIFE OF THE ACTUATOR UNDER NORMAL WORKING CONDITIONS.

AP34SR6	131/167	SPRING RETURN (6 / END)
AP34SR5	159/139	SPRING RETURN (5 / END)
AP34SR4	187/111	SPRING RETURN (4 / END)
AP34SR3	215/83	SPRING RETURN (3 / END)
AP34SR2	242/56	SPRING RETURN (2 / END)
AP34DA	302	DOUBLE ACTING
MODEL NO.	TORQUE (In-Lbs • 80 PSI) (AIR / SPRING)	DESCRIPTION

MATERIAL						NO. AP34		FILE NO.	DO NOT SCALE					
FINISH ANODIZE / EPOXY COATED						TITLE PNEUMATIC ACTUATOR								
UNLESS OTHERWISE SPECIFIED: ALL MACHINED SURFACES TO HAVE 125 RMS FINISH BREAK ALL CORNERS .005/.010 X 45° INTERNAL CORNER RADII .010 MAX. R.						B	A366	02-12-04	DR SSD	DATE 06-20-03	CH'KD LJH	DATE 07-16-03	ENGR LJH	DATE 07-16-03
UNLESS OTHERWISE SPECIFIED ALL DIMENSIONS ARE IN INCHES. TOLERANCES ARE: ANGLES +/- 2 DEG. .X +/- .100 FRACTIONS +/- .015 .XX +/- .015 .XXX +/- .005						LET ECO	DATE	LET ECO	DATE					
THIS PRINT IS THE PROPERTY OF DYNAQUIP CONTROLS AND SHALL NOT BE COPIED, REPRODUCED, LOANED, OR DISPOSED OF DIRECTLY OR INDIRECTLY, NOR USED FOR ANY PURPOSE OTHER THAN THAT FOR WHICH IT IS SPECIFICALLY FURNISHED EXCEPT BY WRITTEN PERMISSION OF DYNAQUIP CONTROLS.														

NO. AP52

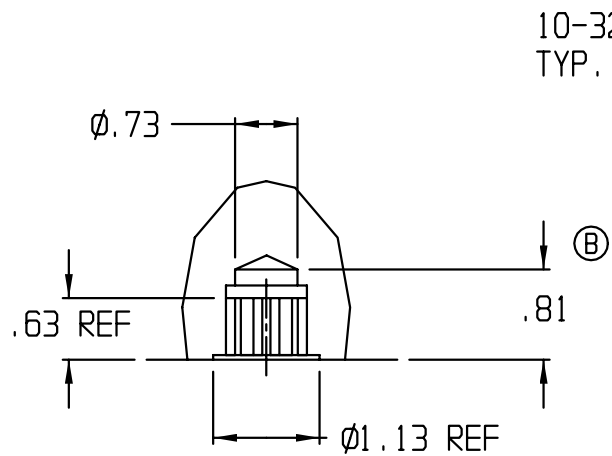

CLEARANCE DEPTH
DETAIL 3

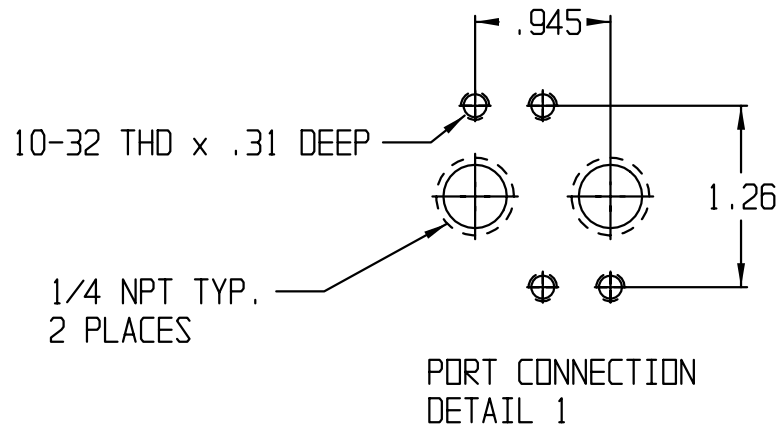

PORT CONNECTION
DETAIL 1

10-32 X .31 DEEP
TYP. 4 PLACES

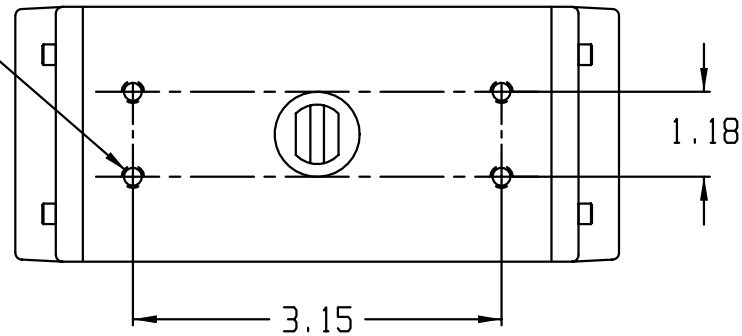

PORT CONNECTION
DETAIL 1

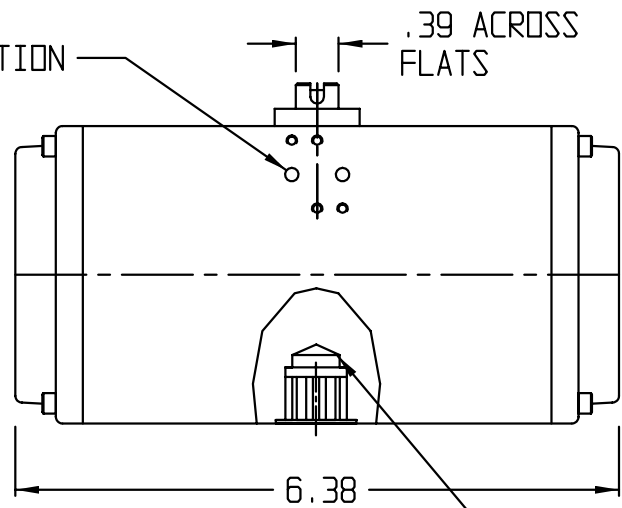

CLEARANCE DEPTH
DETAIL 3

OUTPUT SHAFT
DETAIL 2

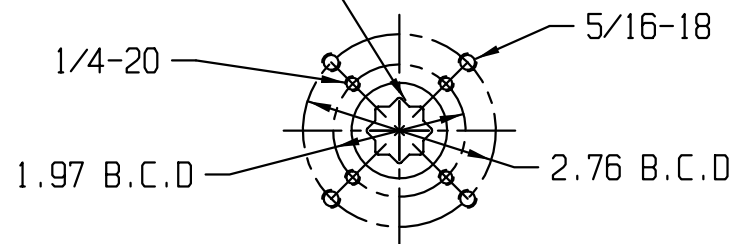

BOTTOM CONNECTION

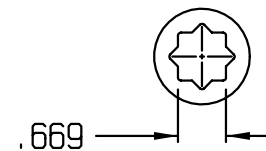

OUTPUT SHAFT
DETAIL 2

MODEL NUMBER PER
CHART BELOW

TORQUE SPEC. PER
CHART BELOW

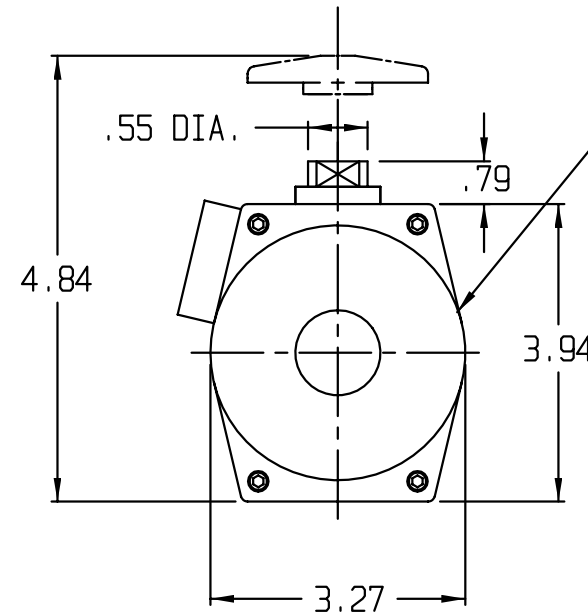

DynaQuip Pneumatic Actuator

MODEL

TORQUE (80 psi) in-lbs

MAX. PRESSURE - 150 PSI. CAUTION: BEFORE DISASSEMBLY REFER TO MAINTENANCE INSTRUCTIONS WITH SPECIAL REFERENCE TO SAFETY NOTES.

800-545-3636
www.dynaquip.com

MADE IN ITALY

PLACE LABEL 145812
THIS SIDE

DynaQuip Control's
PURCHASE ORDER NUMBER

MATERIAL SPECIFICATIONS

- BODY.....ALUMINUM
POLYESTER EPOXY COATED
- PISTON.....ALUMINUM ALLOY
- END CAP.....ALUMINUM ALLOY
EPOXY COATED
- SEAL, O-RINGS.....BUNA N
- BEARINGS.....DELRIN 500
- SCREWS.....304 STAINLESS STEEL
- NUTS.....304 STAINLESS STEEL.

PRESSURE: 20psig TO 150psig MAX.
TEMPERATURE: FROM -10°F TO +195°F
LUBRICATION: FACTORY LUBRICATED FOR THE LIFE OF THE ACTUATOR UNDER NORMAL WORKING CONDITIONS.

AP52SR6	206/312	SPRING RETURN (6 / END)
AP52SR5	259/260	SPRING RETURN (5 / END)
AP52SR4	311/208	SPRING RETURN (4 / END)
AP52SR3	363/156	SPRING RETURN (3 / END)
AP52SR2	415/104	SPRING RETURN (2 / END)
AP52DA	526	DOUBLE ACTING
MODEL NO.	TORQUE (In-Lbs • 80 PSI) (AIR / SPRING)	DESCRIPTION

MATERIAL						NO. AP52		FILE NO.	DO NOT SCALE
FINISH ANODIZE / EPOXY COATED						TITLE PNEUMATIC ACTUATOR			
UNLESS OTHERWISE SPECIFIED: ALL MACHINED SURFACES TO HAVE 125 RMS FINISH BREAK ALL CORNERS .005/.010 X 45° INTERNAL CORNER RADII .010 MAX. R.						B	A366	02-12-04	DR SSD
UNLESS OTHERWISE SPECIFIED ALL DIMENSIONS ARE IN INCHES. TOLERANCES ARE: ANGLES +/- 2 DEG. .X +/- .100 FRACTIONS +/- .015 .XX +/- .015 .XXX +/- .005						A	A262	07-16-03	DATE 06-20-03
THIS PRINT IS THE PROPERTY OF DYNAQUIP CONTROLS AND SHALL NOT BE COPIED, REPRODUCED, LOANED, OR DISPOSED OF DIRECTLY OR INDIRECTLY, NOR USED FOR ANY PURPOSE OTHER THAN THAT FOR WHICH IT IS SPECIFICALLY FURNISHED EXCEPT BY WRITTEN PERMISSION OF DYNAQUIP CONTROLS.						LET ECO	DATE	LET ECO	DATE
						LJH	07-16-03	LJH	07-16-03



NO. AP73

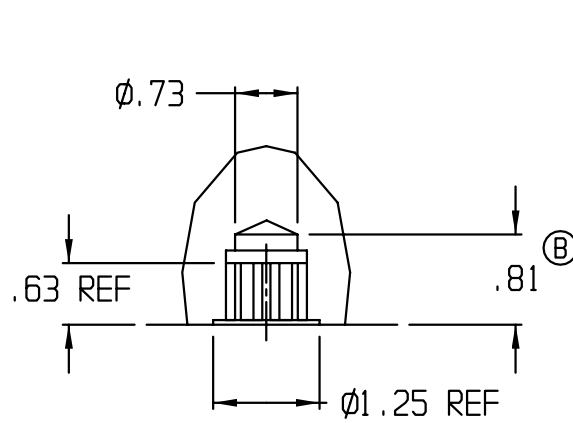

CLEARANCE DEPTH
DETAIL 3

10-32 X .31 DEEP
TYP. 4 PLACES

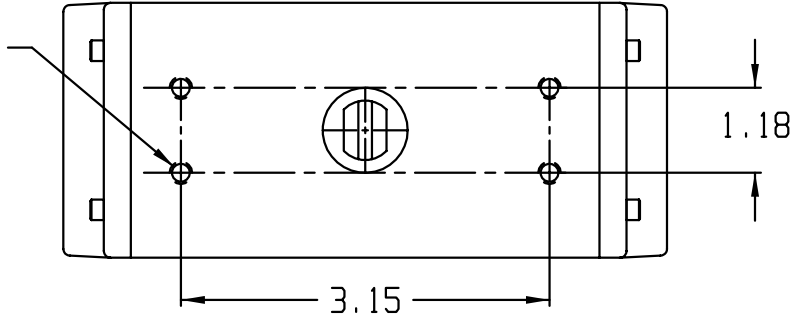

PORT CONNECTION
DETAIL 1

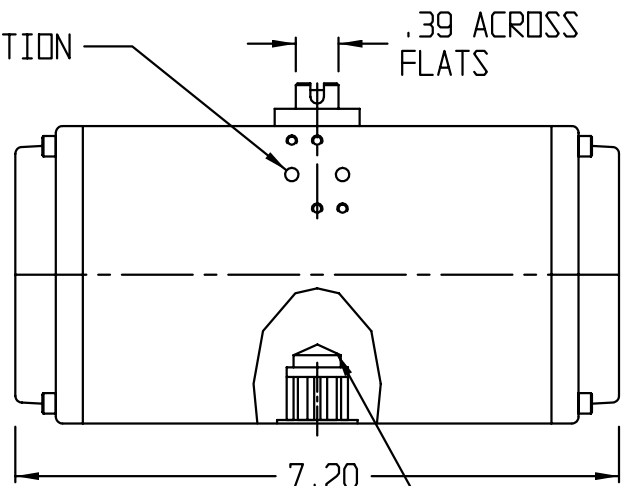

OUTPUT SHAFT
DETAIL 2

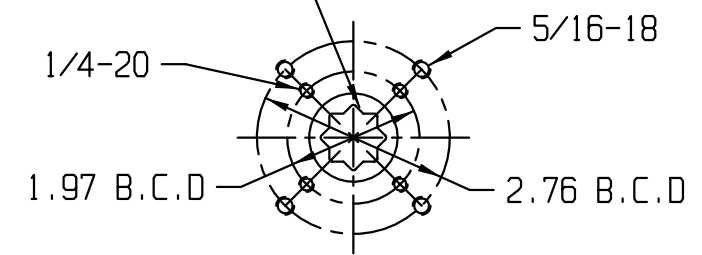

BOTTOM CONNECTION

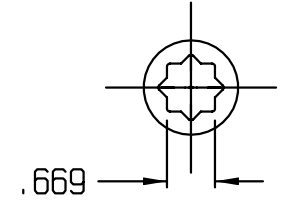

OUTPUT SHAFT
DETAIL 2

MODEL NUMBER PER
CHART BELOW

TORQUE SPEC. PER
CHART BELOW

DynaQuip Pneumatic Actuator

MODEL

TORQUE (80 psi) in-lbs

MAX. PRESSURE - 150 PSI. CAUTION: BEFORE DISASSEMBLY REFER TO MAINTENANCE INSTRUCTIONS WITH SPECIAL REFERENCE TO SAFETY NOTES.

800-545-3636
www.dynaquip.com

MADE IN ITALY

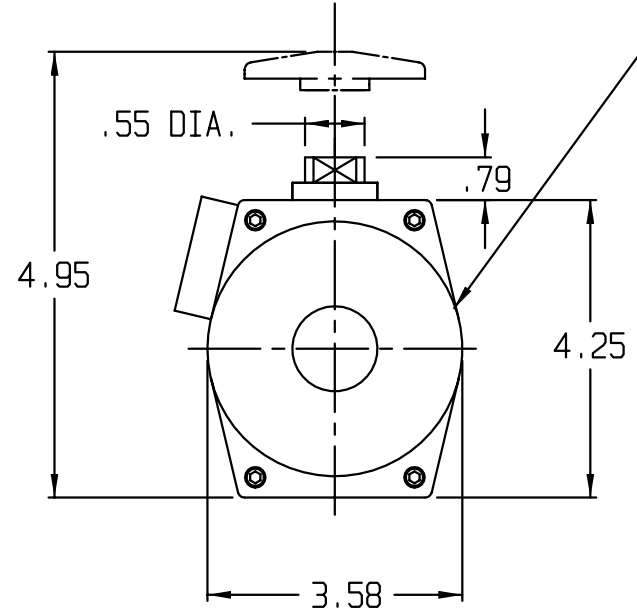

PLACE LABEL 145812
THIS SIDE

DynaQuip Control's
PURCHASE ORDER NUMBER

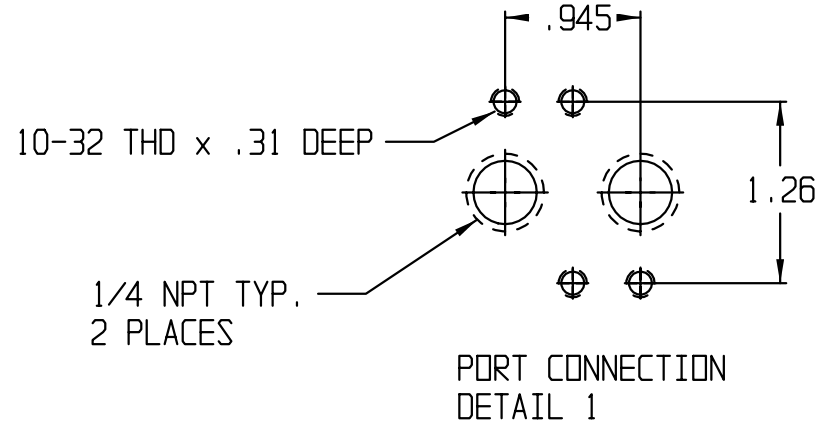

PORT CONNECTION
DETAIL 1

MATERIAL SPECIFICATIONS

- BODY.....ALUMINUM
POLYESTER EPOXY COATED
- PISTON.....ALUMINUM ALLOY
- END CAP.....ALUMINUM ALLOY
EPOXY COATED
- SEAL, O-RINGS.....BUNA N
- BEARINGS.....DELTRIN 500
- SCREWS.....304 STAINLESS STEEL
- NUTS.....304 STAINLESS STEEL.

PRESSURE: 20psig TO 150psig MAX.
TEMPERATURE: FROM -10°F TO +195°F
LUBRICATION: FACTORY LUBRICATED FOR THE LIFE OF THE ACTUATOR UNDER NORMAL WORKING CONDITIONS.

AP73SR6	343/380	SPRING RETURN (6 / END)
AP73SR5	407/317	SPRING RETURN (5 / END)
AP73SR4	471/253	SPRING RETURN (4 / END)
AP73SR3	534/190	SPRING RETURN (3 / END)
AP73SR2	598/127	SPRING RETURN (2 / END)
AP73DA	734	DOUBLE ACTING
MODEL NO.	TORQUE (In-Lbs • 80 PSI) (AIR / SPRING)	DESCRIPTION

MATERIAL						NO. AP73		FILE NO.	DO NOT SCALE					
FINISH ANODIZE / EPOXY COATED						TITLE PNEUMATIC ACTUATOR								
UNLESS OTHERWISE SPECIFIED: ALL MACHINED SURFACES TO HAVE 125 RMS FINISH BREAK ALL CORNERS .005/.010 X 45° INTERNAL CORNER RADII .010 MAX. R. UNLESS OTHERWISE SPECIFIED ALL DIMENSIONS ARE IN INCHES. TOLERANCES ARE: ANGLES +/- 2 DEG. .X +/- .100 FRACTIONS +/- .015 .XX +/- .015 .XXX +/- .005						B	A366	02-12-04	DR SSD	DATE 06-20-03	CH'KD LJH	DATE 07-16-03	ENGR LJH	DATE 07-16-03
						A	A262	07-16-03						
THIS PRINT IS THE PROPERTY OF DYNAQUIP CONTROLS AND SHALL NOT BE COPIED, REPRODUCED, LOANED, OR DISPOSED OF DIRECTLY OR INDIRECTLY, NOR USED FOR ANY PURPOSE OTHER THAN THAT FOR WHICH IT IS SPECIFICALLY FURNISHED EXCEPT BY WRITTEN PERMISSION OF DYNAQUIP CONTROLS.														