

ifm electronic

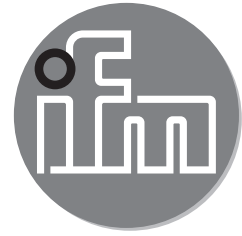

Operating instructions
Diffuse reflection sensor with
background suppression

efector200[®]

OIH5xx

UK

7200015 / 00 03 / 2013

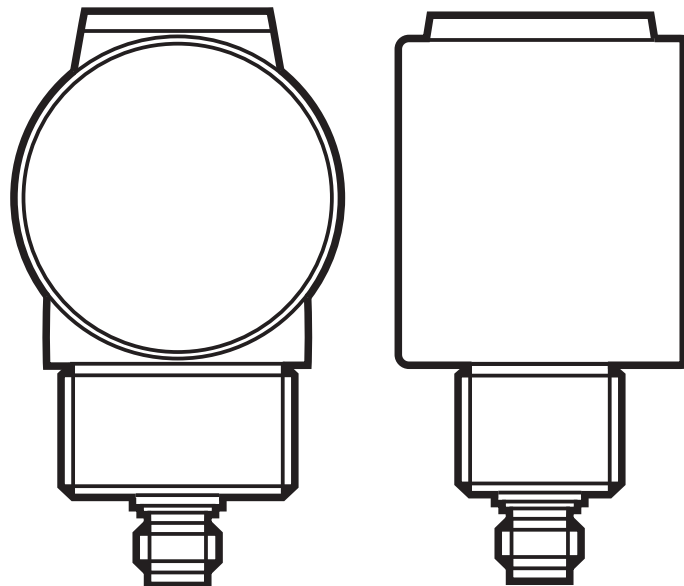

1 Preliminary note

1.1 Symbols used

- ▶ Instruction
- > Reaction, result
- [...] Designation of pushbuttons, buttons or indications
- Cross-reference



Important note

Non-compliance can result in malfunctions or interference.

2 Functions and features

The diffuse reflection sensor detects objects and materials without contact and indicates their presence by a switching signal.

Range: → type label.

3 Installation

- ▶ Align the diffuse reflection sensor to the object to be detected.
- ▶ Secure it to a bracket.

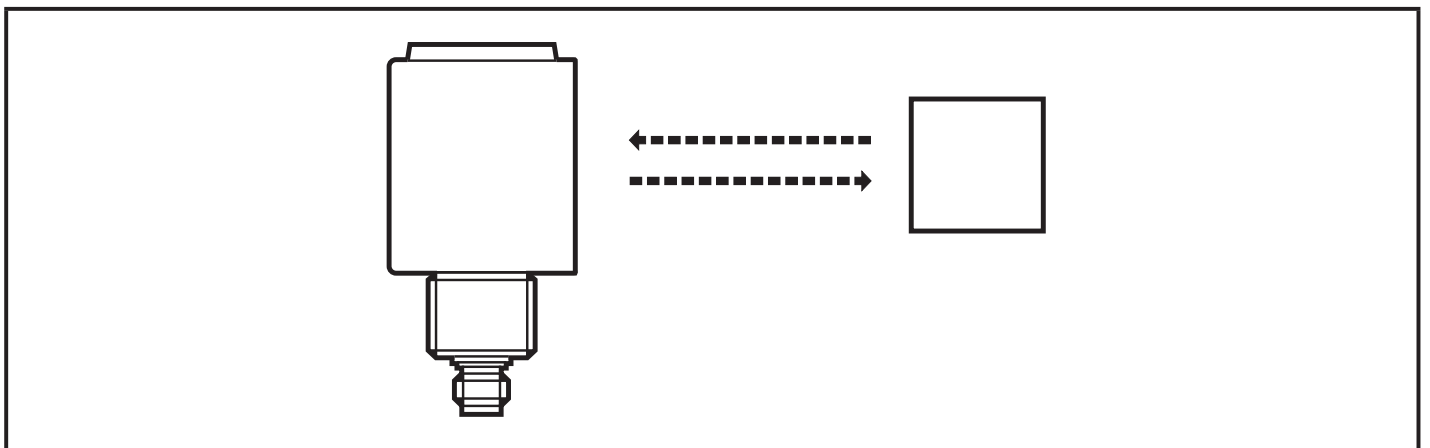

Note:

The objects to be detected are to move transversely to the lens of the sensor.

- ▶ In case of other directions of movement it should be tested before safe switching is guaranteed.

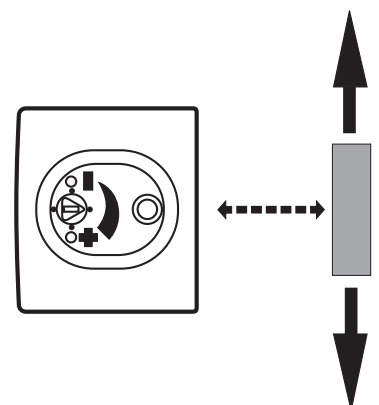

4 Operating and display elements

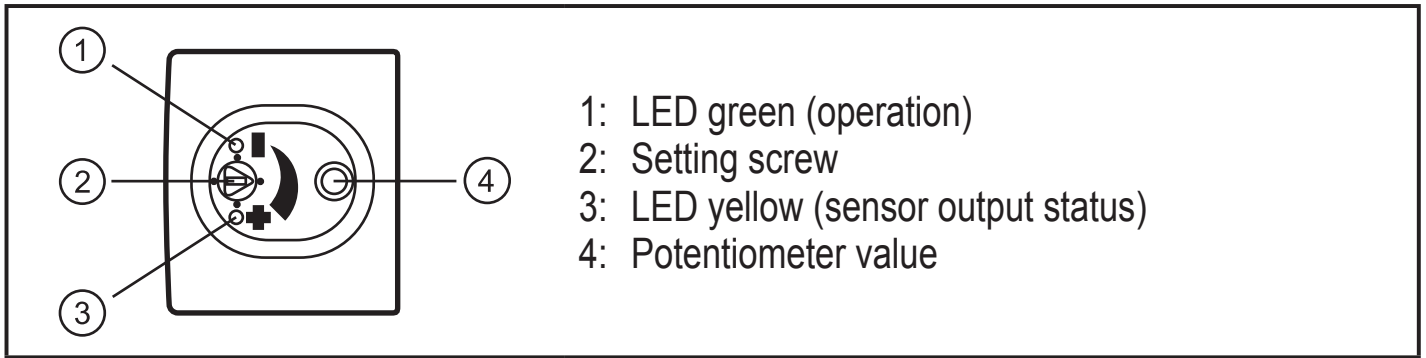

5 Electrical connection

UK



The unit must be connected by a qualified electrician.

- ▶ The national and international regulations for the installation of electrical equipment must be adhered to.
 - ▶ Ensure voltage supply to EN 50178.
- ▶ Disconnect power.
- ▶ Connect the unit as follows:

PNP

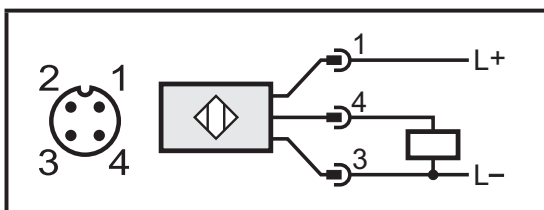

NPN

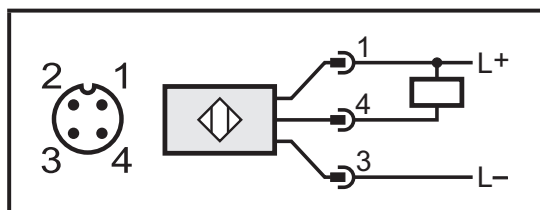

6 Settings

Sensitivity setting

- ▶ Measure the requested range.
Example: object distance 400 mm

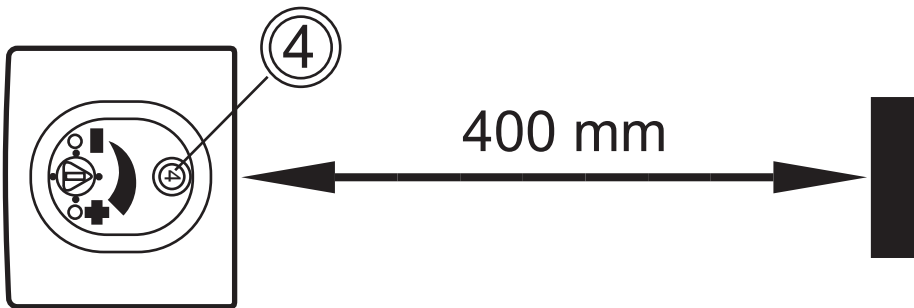

Turn	Sensing range
1	100 mm
2	200 mm
3	300 mm
4	400 mm
5	500 mm
6	600 mm
7	700 mm
8	800 mm

Set the range:

- ▶ Turn the setting screw of the potentiometer clockwise until the required range to the object has been reached. Each figure corresponds to 100 mm.
- ▶ If the setting fails, increase the potentiometer value until the object is detected.

7 Operation

- ▶ Check whether the unit operates correctly.
- > The yellow LED is lit when the switching output is switched.
- > The green LED is lit when the sensor is ready for operation.

8 Maintenance, repair, disposal

- ▶ Keep the lens of the sensor free from soiling.
- ▶ For cleaning do not use any solvents or cleaning agents which could damage the plastic parts.
- ▶ After use dispose of the unit in an environmentally friendly way in accordance with the applicable national regulations.

Faulty sensors must only be repaired by the manufacturer.

Technical data and further information at www.ifm.com

