

ifm electronic



Operating instructions
Combined pressure sensor

efector500[®]

PN22xx

UK

704829 / 00 08 / 2010

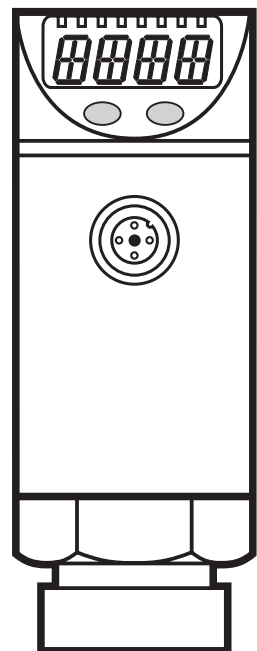

Contents

1	Preliminary note.....	3
1.1	Symbols used	3
2	Safety instructions	3
3	Function and features	4
4	Function.....	5
4.1	Communication, parameter setting and evaluation	5
4.2	Switching function.....	6
4.3	Analogue function	6
5	Installation.....	8
6	Electrical connection.....	8
7	Operating and display elements	9
8	Menu.....	10
8.1	Menu structure.....	10
8.2	Explanation of the menu	11
9	Parameter setting	12
9.1	Parameter setting general	12
9.2	Setting the output signal	14
9.2.1	Setting the output function.....	14
9.2.2	Setting the switching limits	14
9.2.3	Scaling the analogue value	14
9.3	User settings (optional).....	15
9.3.1	Setting the unit of measurement for the system pressure	15
9.3.2	Configuring the display	15
9.3.3	Zero-point calibration.....	15
9.3.4	Setting the delay time for the switching outputs	15
9.3.5	Setting the output polarity.....	16
9.3.6	Setting the damping for the switching outputs.....	16
9.3.7	Setting the damping for the analogue output.....	16
9.4	Service functions	16
9.4.1	Reading the min./max. values for the system pressure.....	16
10	Operation.....	17
10.1	Read the set parameter values	17
10.2	Fault indication	17

11 Scale drawing	18
12 Technical data.....	18
12.1 Setting ranges	20
13 Factory setting	22

1 Preliminary note

1.1 Symbols used

- ▶ Instruction
- > Reaction, result
- [...] Designation of buttons, switches or indications
- Cross-reference



Important note

Non-compliance can result in malfunctions or interference.

UK

2 Safety instructions

- Read this document before installing the unit. Ensure that the product is suitable for your application without any restrictions.
- Non-adherence to the operating instructions or technical data can lead to personal injury and/or damage to property.
- In all applications check compliance of the product materials (→ chapter 12 Technical data) with the media to be measured.
- Use in gases at pressures > 25 bar only after contacting the manufacturer ifm.

For units with cULus approval and the scope of validity cULus:

The device shall be supplied from an isolating transformer having a secondary Listed fuse rated as noted in the following table.

Overcurrent protection		
Control-circuit wire size		Maximum protective device rating Ampere
AWG	(mm ²)	
26	(0.13)	1
24	(0.20)	2
22	(0.32)	3
20	(0.52)	5
18	(0.82)	7
16	(1.3)	10

The Sensor shall be connected only by using any R/C (CYJV2) cord, having suitable ratings.

3 Function and features

The pressure sensor detects the system pressure of machines and installations.

Applications

Type of pressure: relative pressure

Order no.	Measuring range		Permissible overload pressure		Bursting pressure	
	PSI	bar	PSI	bar	PSI	bar
PN2220	0...5 800	0...400	8 700	600	14 500	1 000
PN2221	0...3 630	0...250	5 800	400	12 300	850
PN2222	0...1 450	0...100	4 350	300	9 400	650
PN2223	-14.5...362.5	-1...25	1 450	100	5 075	350
PN2224	-14.5...145	-1...10	1088	75	2 175	150
PN2226	-1.45...36.25	-0.13...2.50	290	20	725	50
	PSI	mbar	PSI	bar	PSI	bar
PN2209	-14.5...14.5	-1 000...1 000	290	20	725	50
PN2227	-0.74...14.5	-50...1 000	145	10	450	30
	inH ₂ O	mbar	inH ₂ O	bar	inH ₂ O	bar
PN2228	-5.0...100.4	-12.5...250.0	4 000	10	12 000	30

MPa = bar ÷ 10 / kPa = bar × 100



Static and dynamic overpressures exceeding the indicated overload pressure are to be avoided by taking appropriate measures.

The indicated bursting pressure must not be exceeded. Even if the bursting pressure is exceeded only for a short time, the unit can be destroyed.

NOTE: Risk of injury!

Use in gases at pressures > 25 bar only after contacting the manufacturer ifm.

4 Function

4.1 Communication, parameter setting and evaluation

- The unit shows the current system pressure on its display.
- It generates 2 output signals according to the parameter setting.

OUT1	• switching signal for pressure limit values.
OUT2	• switching signal for pressure limit values. • analogue signal for pressure (4...20 mA or 0...10V).

- It moreover provides the process data via IO-Link.
 - The unit is laid out for fully bidirectional communication. So, the following options are possible:
 - Remote display: reading and display of the current system pressure.
 - Remote evaluation: transfer of switching signals (only with PP2001).
 - Remote parameter setting: reading and changing current parameter settings with PP2001, FDT service program ifm Container or via IO-Link.
 - Using PP2001 and the FDT service program ifm Container, the current parameter settings can be stored and transferred to other units of the same type.
- The program library of the available DTM objects can be found at www.ifm.com → Service → Download.

Device-specific parameter lists for IO-Link parameter setting are available at: www.ifm.com → Select your country → Data sheet direct:

4.2 Switching function

OUTx changes its switching state if it is above or below the set switching limits (SPx, rPx). The following switching functions can be selected:

- Hysteresis function / normally open: [OUx] = [Hno] (→ fig. 1).
- Hysteresis function / normally closed: [OUx] = [Hnc] (→ fig. 1).

First the set point (SPx) is set, then the reset point (rPx) at the requested distance.

- Window function / normally open: [OUx] = [Fno] (→ fig. 2).
- Window function / normally closed: [OUx] = [Fnc] (→ fig. 2).

The width of the window can be set by means of the distance between SPx and rPx. SPx = maximum value, rPx = minimum value.

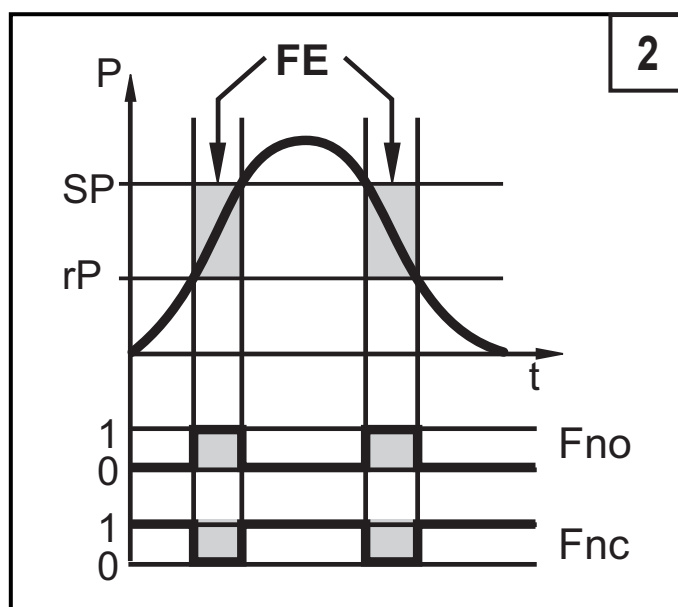
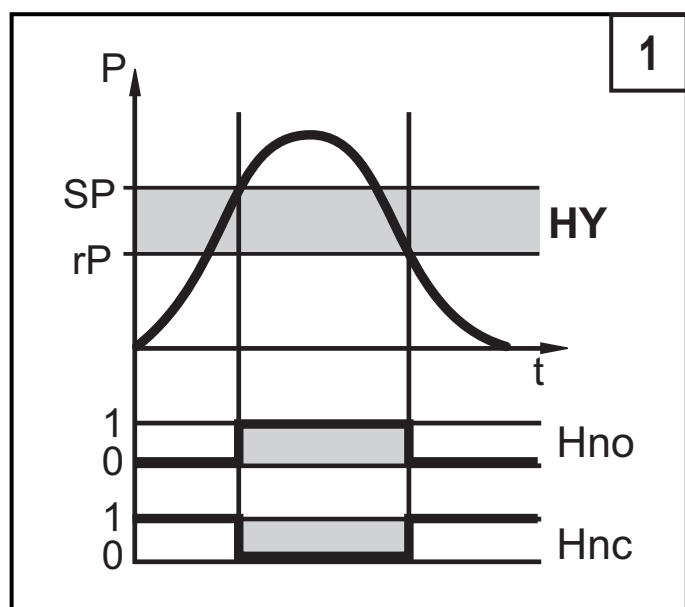

P = system pressure; HY = hysteresis; FE = window

4.3 Analogue function

- [OU2] defines whether the set measuring range is provided as a 4...20 mA signal ([OU2] = [I]) or a 0...10 V signal ([OU2] = [U]).
- The analogue start point [ASP] determines at which measured value the output signal is 4 mA or 0 V.
- The analogue end point [AEP] determines at which measured value the output signal is 20 mA or 10 V.

Minimum distance between [ASP] and [AEP] = 25 % of the span.

Voltage output 0 ... 10 V

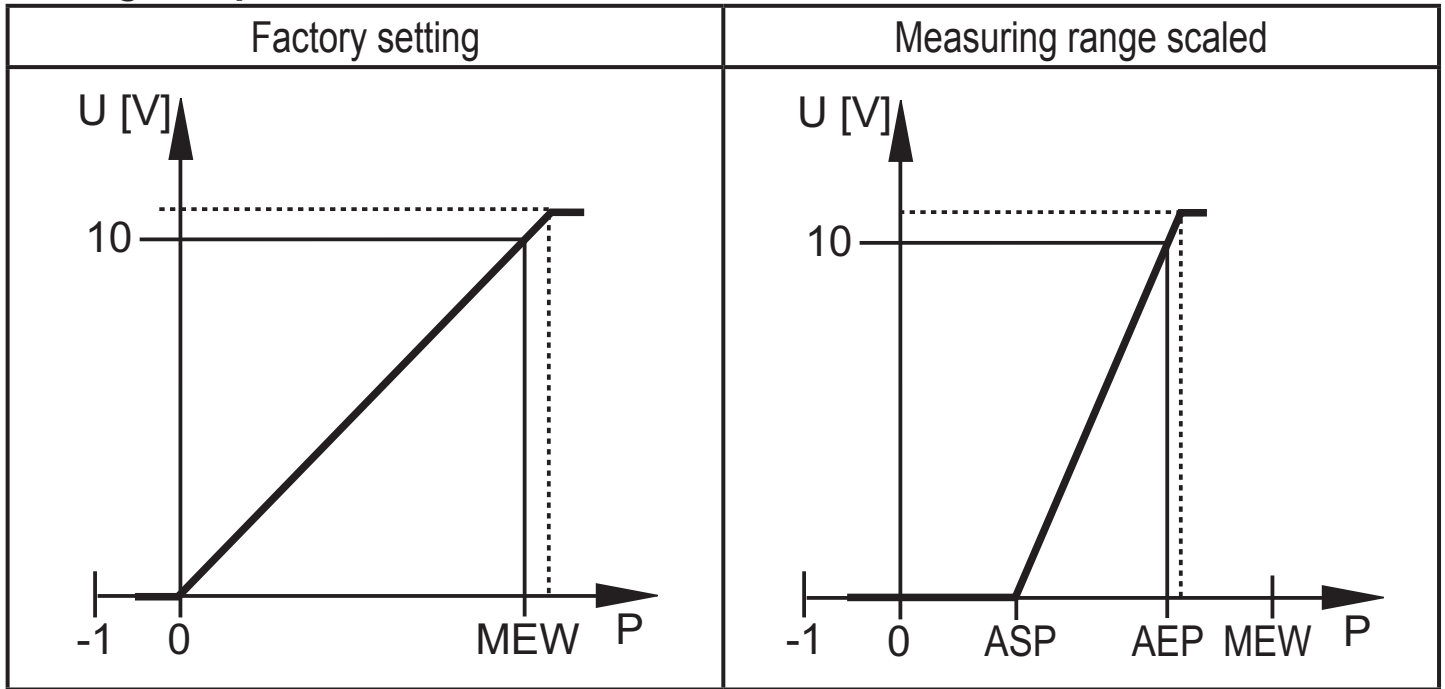

P = system pressure, MEW = final value of the measuring range
 In the set measuring range the output signal is between 0 and 10 V.
 It is also indicated:
 System pressure above the measuring range: output signal > 10 V.

Current output 4 ... 20 mA

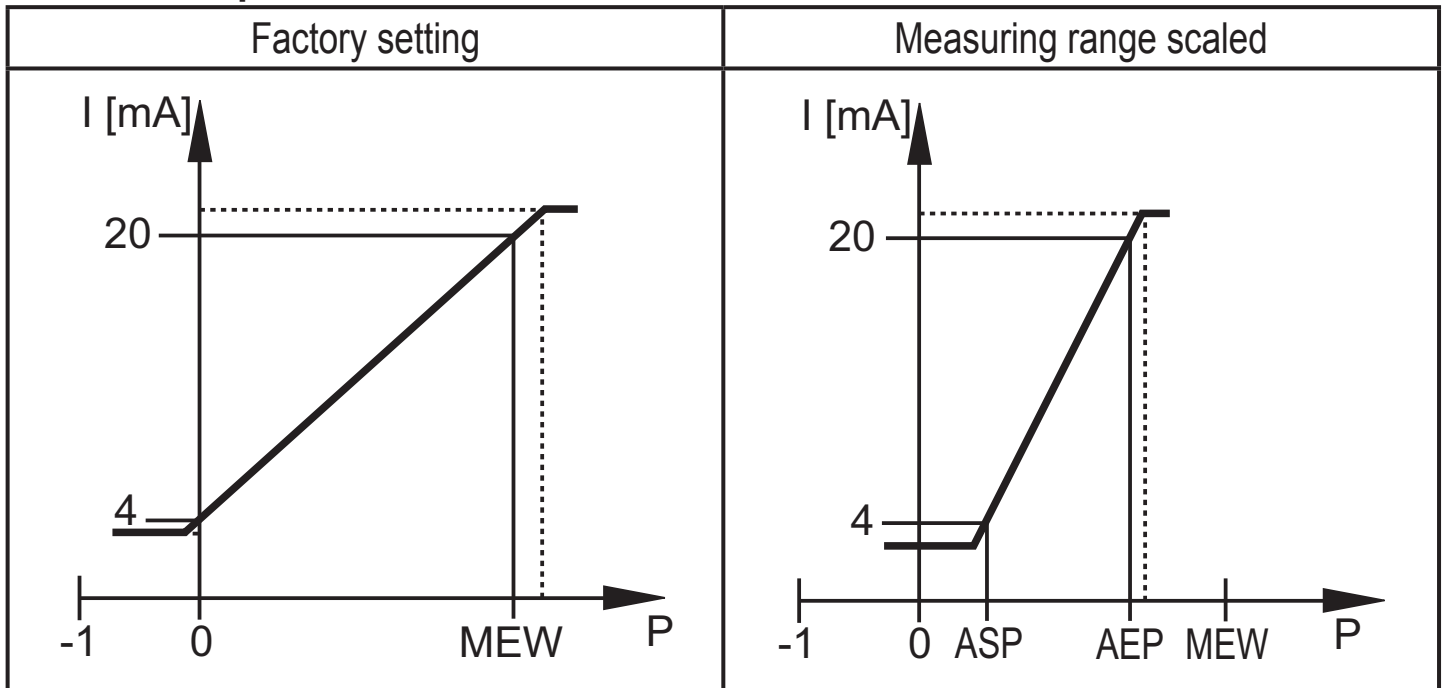

P = system pressure, MEW = final value of the measuring range
 In the set measuring range the output signal is between 4 and 20 mA.

Also signalled:

- System pressure above the measuring range: output signal > 20 mA.
- System pressure below the measuring range: output signal 4...3.8 mA.

5 Installation



Before mounting and removing the sensor, make sure that no pressure is applied to the system.

- ▶ Insert the unit in a ¼" NPT process connection.
- ▶ Tighten firmly.

6 Electrical connection



The unit must be connected by a qualified electrician.

The national and international regulations for the installation of electrical equipment must be adhered to.

Voltage supply to EN50178, SELV, PELV.

- ▶ Disconnect power.
- ▶ Connect the unit as follows:

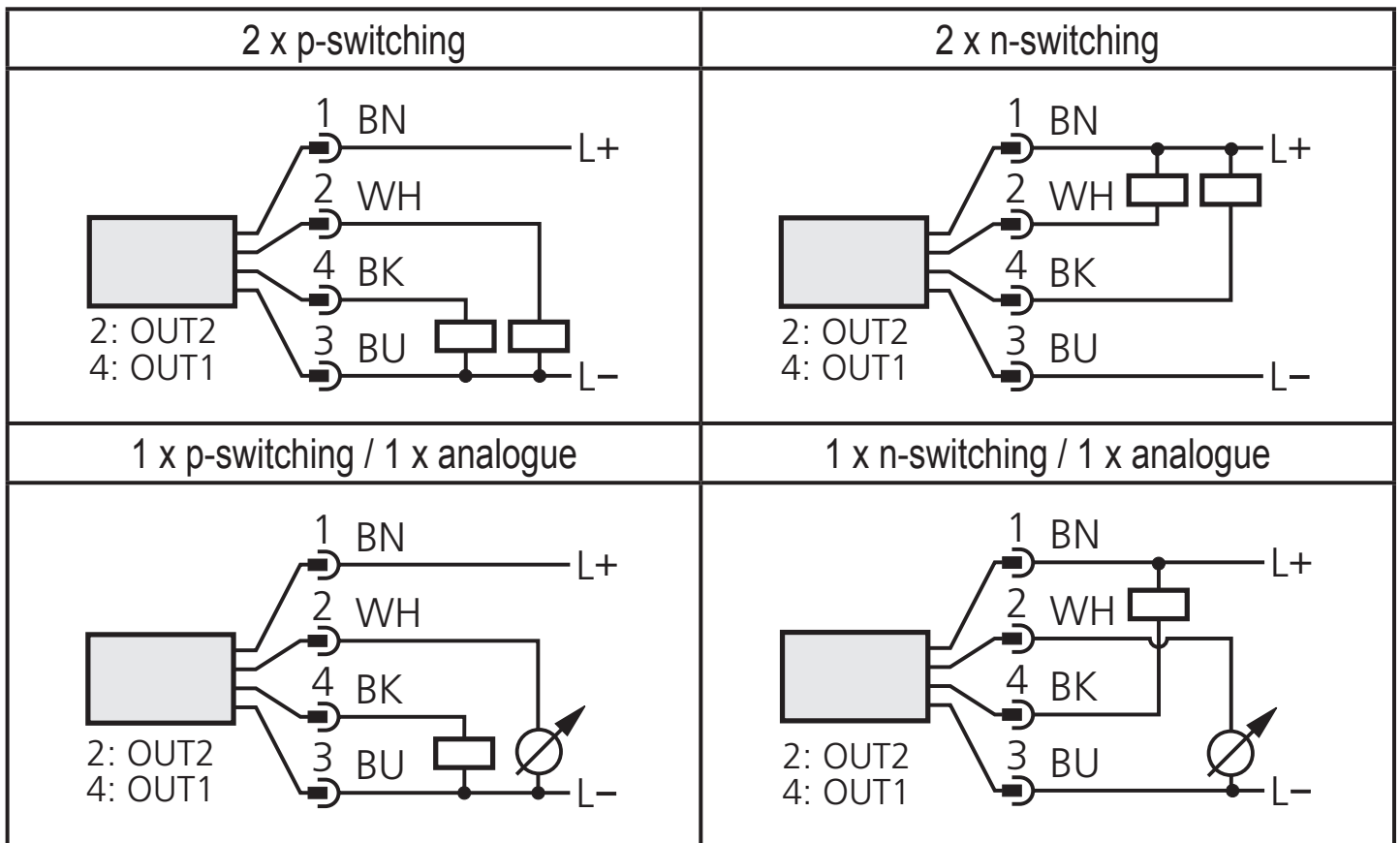

Pin 4 (OUT1) = Data channel for bidirectional communication. Note: not to be used when OUT1 = n-switching.

Core colours of ifm sockets:

1 = BN (brown), 2 = WH (white), 3 = BU (blue), 4 = BK (black).

7 Operating and display elements

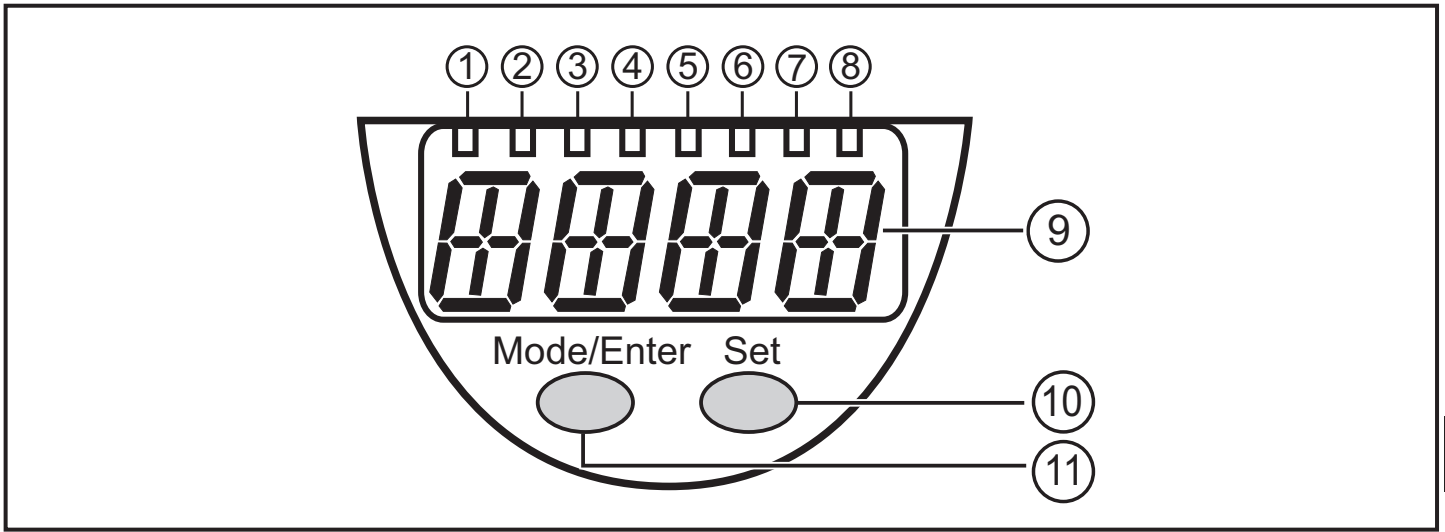

UK

1 to 8: Indicator LEDs

- LED 1 to LED 6 = system pressure in unit of measurement as indicated on the label.
- LEDs 4 to 6 not used for units with 3 adjustable units of measurement.
- LEDs 5 and 6 not used for units with 4 adjustable units of measurement.
- LED 7, LED 8 = switching state of the respective output.

9: Alphanumeric display, 4 digits

- Indication of the current system pressure.
- Indication of the parameters and parameter values.

10: Set pushbutton

- Setting of the parameter values (scrolling by holding pressed, incremental by pressing briefly).

11: Mode/Enter pushbutton

- Selection of the parameters and acknowledgement of the parameter values.

8 Menu

8.1 Menu structure

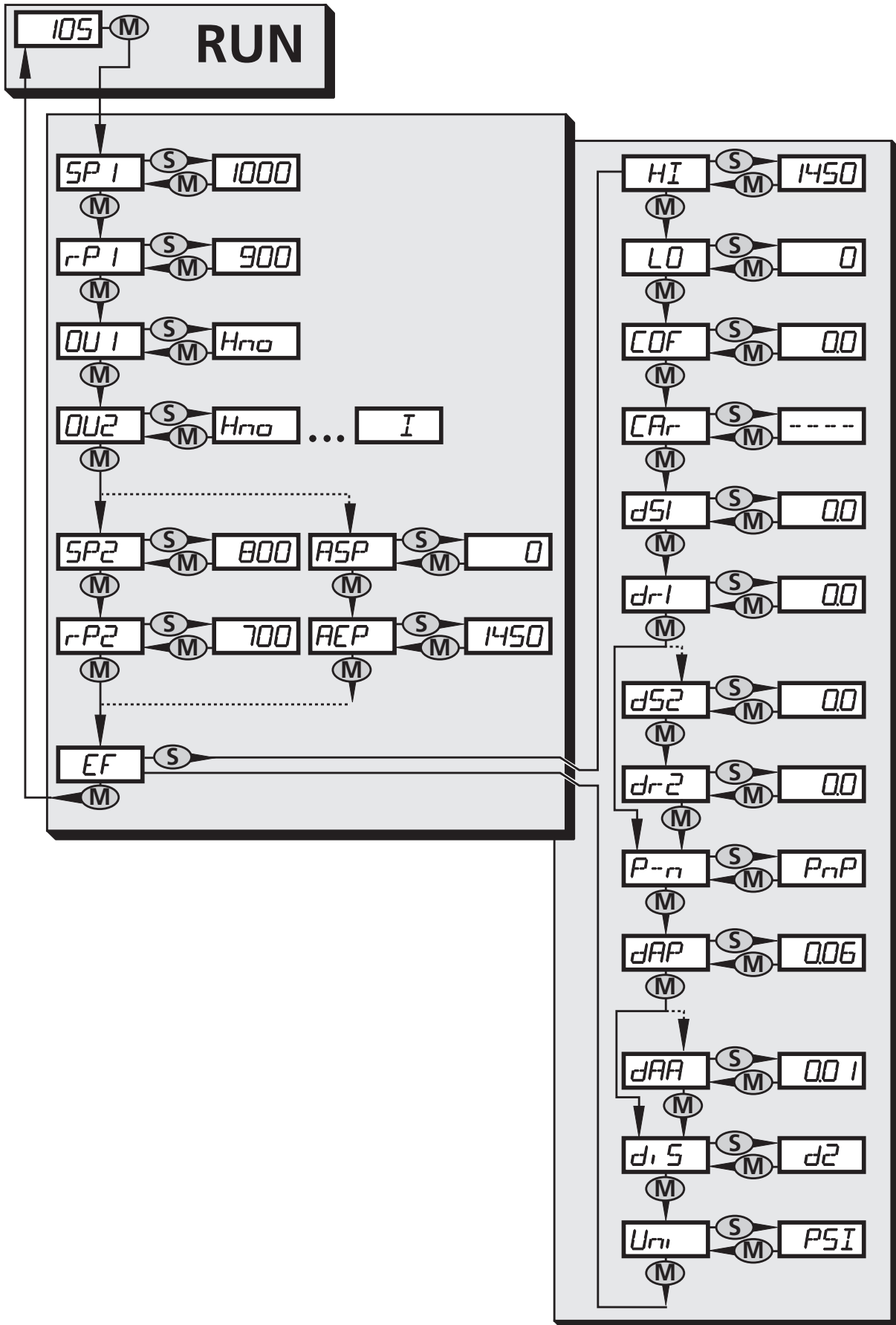

8.2 Explanation of the menu

SP1/rP1	Maximum / minimum value for system pressure, at which output 1 changes its switching status.
SP2/rP2	Maximum / minimum value for system pressure, at which output 2 changes its switching status.
OU1	Output function for OUT1: <ul style="list-style-type: none"> Switching signal for the limit values: hysteresis function [H ..] or window function [F ..], normally open [. no] or normally closed [. nc] each.
OU2	Output function for OUT2: <ul style="list-style-type: none"> Switching signal for the limit values: hysteresis function [H ..] or window function [F ..], normally open [. no] or normally closed [. nc] each. Analogue signal for the current system pressure: 4...20 mA [I] or 0...10 V [U].
ASP	Analogue start point for the system pressure: measured value at which 4 mA / or 0 V are output.
AEP	Analogue end point for the system pressure: measured value at which 20 mA / or 10 V are output.
EF	Extended functions / Opening menu level 2.
HI	Maximum value memory for the system pressure.
LO	Minimum value memory for the system pressure.
COF	Zero point calibration.
CAr	Calibration reset.
dS1/dS2	Switch-on delay for für OUT1 / OUT2.
dr1/dr2	Reset delay für OUT1 / OUT2.
P-n	Output polarity: pnp / npn
dAP	Damping for the switching outputs
dAA	Damping for the analogue output
diS	Update rate and orientation of the display.
Uni	Standard unit of measurement for the system pressure.

UK

9 Parameter setting

During the parameter setting process the unit remains in the operating mode. It continues its monitoring function with the existing parameters until parameter setting has been terminated.

9.1 Parameter setting general

Each parameter setting requires 3 steps:

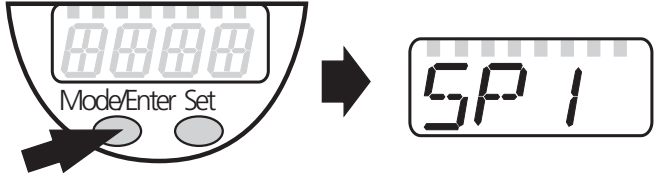
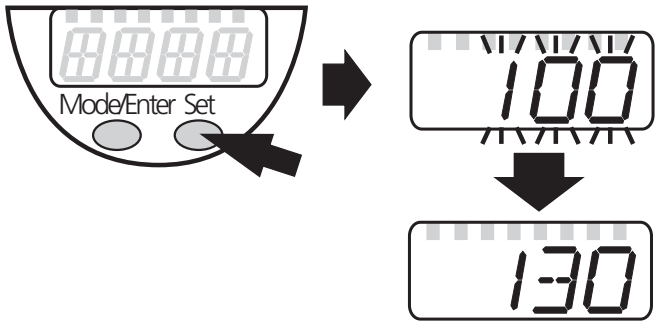
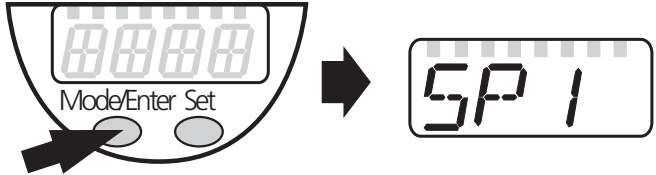
<p>1</p>	<p>Parameter selection</p> <p>▶ Press [Mode/Enter] until the requested parameter is displayed.</p>	
<p>2</p>	<p>Setting of the parameter value</p> <p>▶ Press [Set] and keep it pressed.</p> <p>> Current setting value of the parameter flashes for 5 s.</p> <p>> After 5 s: The setting value is changed: incremental by pressing briefly or scrolling by holding pressed.</p>	
<p>The numerical values are incremented continuously. If the value is to be reduced: Let the display move to the maximum setting value. Then the cycle starts again at the minimum setting value.</p>		
<p>3</p>	<p>Acknowledgement of the parameter value</p> <p>▶ Press [Mode/Enter] briefly.</p> <p>> The parameter is displayed again. The new setting value is stored.</p>	
<p>Setting of other parameters:</p> <p>▶ Start again with step 1.</p>		
<p>Finishing the parameter setting:</p> <p>▶ Press [Mode/Enter] several times until the current measured value is displayed or wait for 15 s.</p> <p>> The unit returns to the operating mode.</p>		

- If [SLoc] is displayed when attempting a modification of a parameter value, the sensor is locked via software. This locking can only be removed via a parameter setting software.
- In case of parameter setting with the user interface of the ifm Container program, the values can be directly entered in the specified fields.

- For IO-Link parameter setting → device-specific parameter lists at: www.ifm.com → Select your country → Data sheet direct:
- Changing from menu level 1 to menu level 2:

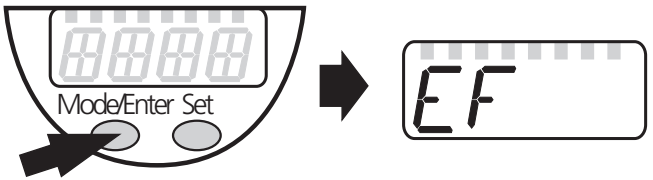
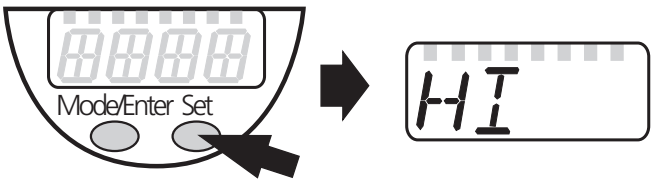
<ul style="list-style-type: none"> ▶ Press [Mode/Enter] until [EF] is displayed. <p>If the submenu is protected with an access code, [Cod1] flashes in the display.</p> <ul style="list-style-type: none"> ▶ Press [Set] and keep it pressed until the valid code no. is displayed. ▶ Press [Mode/Enter] briefly. <p>On delivery by ifm electronic: no access restriction.</p>	
<ul style="list-style-type: none"> ▶ Press [Set] briefly. > The first parameter of the sub-menu is displayed (here: [HI]). 	
<p>With the user interface of the ifm Container program:</p> <ul style="list-style-type: none"> ▶ Activate the [EF] button. <p>If menu level 2 is protected by an access code, the input field for the code no. is activated.</p> <ul style="list-style-type: none"> ▶ Enter valid code no. 	

UK

- Locking / unlocking

The unit can be locked electronically to prevent unintentional wrong settings.

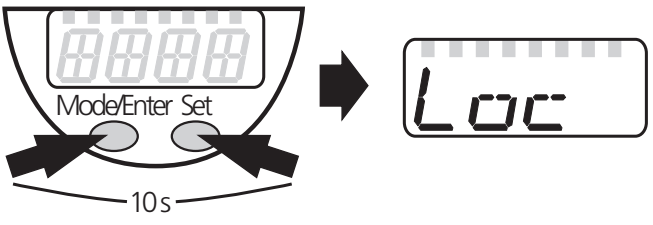
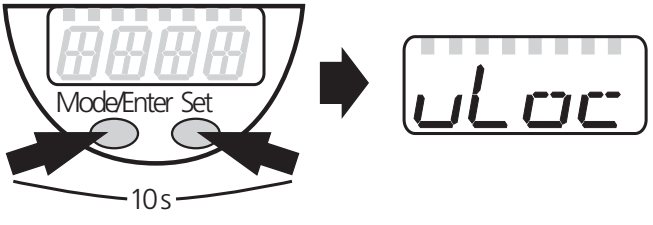
<ul style="list-style-type: none"> ▶ Make sure that the unit is in the normal operating mode. ▶ Press [Mode/Enter] + [Set] for 10 s. > [Loc] is displayed. 	
<p>During operation: [Loc] is briefly displayed if you try to change parameter values.</p>	
<ul style="list-style-type: none"> ▶ Press [Mode/Enter] + [Set] for 10 s. > [uLoc] is displayed. 	

On delivery: Unlocked.

- Timeout:

If no button is pressed for 15 s while the parameters are being set, the unit returns to the operating mode with unchanged values.

9.2 Setting the output signal

9.2.1 Setting the output function

<p>▶ Select [OU1] and set the switching function: [Hno] = hysteresis function / normally open, [Hnc] = hysteresis function / normally closed, [Fno] = window function / normally open, [Fnc] = window function / normally closed.</p>	<p>OU 1</p>
<p>▶ Select [OU2] and set the function: [Hno] = hysteresis function / normally open, [Hnc] = hysteresis function / normally closed, [Fno] = window function / normally open, [Fnc] = window function / normally closed, [I] = current signal proportional to the pressure 4...20 mA, [U] = voltage signal proportional to the pressure 0...10 V.</p>	<p>OU 2</p>

9.2.2 Setting the switching limits

<p>▶ Select [SP1] / [SP2] and set the value at which the output switches.</p>	<p>SP 1 SP 2</p>
<p>▶ Select [rP1] / [rP2] and set the value at which the output switches back. rPx is always lower than SPx. The unit only accepts values which are lower than SPx.</p>	<p>r-P 1 r-P 2</p>

9.2.3 Scaling the analogue value

<p>▶ Select [ASP] and set value at which 4 mA / 0 V are output.</p>	<p>ASP</p>
<p>▶ Select [AEP] and set value at which 20 mA / 10 V are output. Minimum distance between ASP and AEP = 25 % of the span (scaling factor 1:4).</p>	<p>AEP</p>

9.3 User settings (optional)

9.3.1 Setting the unit of measurement for the system pressure



<p>▶ Select [Uni] and set the unit of measurement: [bAr], [mbAr] [MPa], [kPa] [PSI] [IH2O] (only PN2209, PN2227, PN2228) [inHG] (only PN2209) [mmWS] (only PN2228)</p>	
--	---

9.3.2 Configuring the display

UK

<p>▶ Select [diS] and set update rate and orientation of the display: [d1]: Update of the measured value every 50 ms. [d2]: Update of the measured value every 200 ms. [d3]: Update of the measured value every 600 ms. [Ph]: Display of the measured peak value remains for a short time (peak hold). [rd1], [rd2], [rd3], [rPh]: Display like d1, d2, d3, Ph; rotated by 180°. [OFF]: The display is deactivated in the operating mode.</p>	
--	---

9.3.3 Zero-point calibration

<p>▶ Select [COF] and set a value between -5 % and 5 % of the final value of the measuring range (for PN2209 ± 5 % of the span). The internal measured value "0" is shifted by this amount.</p>	
<p>Resets the calibration set by COF to the value set at the factory. ▶ Press [Mode/Enter] until [CAr] is displayed. ▶ Press [Set] and keep it pressed until [----] is displayed. ▶ Press [Mode/Enter] briefly.</p>	

9.3.4 Setting the delay time for the switching outputs

<p>[dS1] / [dS2] = switch-on delay for OUT1 / OUT2. [dr1] / [dr2] = switch-off delay for OUT1 / OUT2. ▶ Select [dS1], [dS2], [dr1] or [dr2], set value between 0.1 und 50 s (at 0.0 the delay time is not active).</p>	
--	---

9.3.5 Setting the output polarity

▶ Select [P-n], set [PnP] or [nPn].	P--n
-------------------------------------	------

9.3.6 Setting the damping for the switching outputs

▶ Select [dAP], set value between 0.01 ... 4.00 s; (at 0.00 [dAP] time is not active). dAP-value = response time between pressure change and change of the switching status in seconds (s). Correlation between switching frequency and [dAP]: $f_{\max} = 1 \div 2dAP..$	dAP
---	-----

9.3.7 Setting the damping for the analogue output

▶ Select [dAA], set value between 0.01 ... 4.00 s; (at 0.00 [dAA] time is not active). dAA-value = response time between pressure change and change of the switching status in seconds (s). [dAA] affects the IO-Link process data.	dAA
---	-----

9.4 Service functions

9.4.1 Reading the min./max. values for the system pressure

▶ Select [HI] or [LO], press [Set] briefly. [HI] = maximum value, [LO] = minimum value. Delete memory: ▶ Select [HI] or [LO]. ▶ Press [Set] until [----] is displayed. ▶ Press [Mode/Enter] briefly.	HI LO
---	----------

10 Operation

After power on of the supply voltage the unit is in the Run mode (= normal operation). It carries out its measurement and evaluation functions and generates output signals according to the set parameters.

Operating indicators → chapter 7 Operating and display elements.

10.1 Read the set parameter values

- ▶ Press [Mode/Enter] briefly to scroll the parameters.
- ▶ Press [Set] briefly to indicate the corresponding parameter value for 15 s. After another 15 s the unit returns to the Run mode.

UK

10.2 Fault indication

[OL]	overload pressure (measuring range exceeded)
[UL]	underpressure range (measuring range below the minimum value)
[SC1]	short circuit in OUT1*
[SC2]	short circuit in OUT2*
[SC]	short circuit in both switching outputs*
*The output concerned is switched off as long as the short circuit exists. This faults are indicated even if the display is deactivated.	

11 Scale drawing

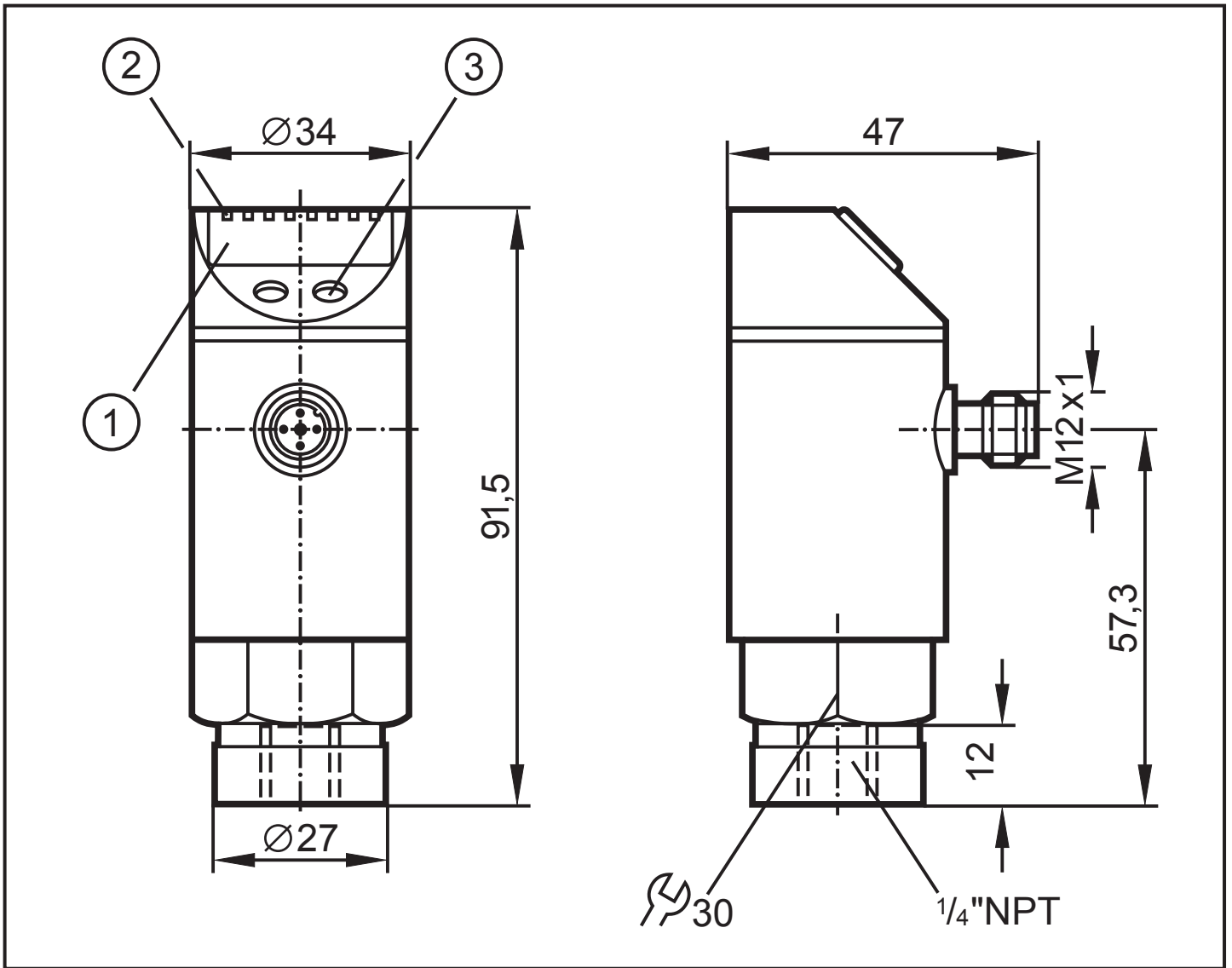

Dimensions are in millimeters
 1: display; 2: LED's; 3: programming button

12 Technical data

Operating voltage [V].....	18...32 DC ¹⁾
Current consumption [mA].....	< 35
Current rating [mA].....	2 x 250
Protection: short circuit, reverse polarity, overload	
Voltage drop [V]	< 2
Power-on delay [s]	0.3
Min. response time switching outputs [ms]	1.5
Switching frequency [Hz]	max. 500
Analogue output	4 ... 20 mA / 0...10 V
Max. load current output [Ω]	(U _b - 10) x 50
Min. load with voltage output[Ω]	2000
Min. response time analogue output [ms]	3

Communication interface	IO-Link 1.0
Baud rate [kBAUD]	38.4
Accuracy / deviations (in % of the span) ²⁾	
- Accuracy of switch point	< ± 0.4
- Characteristics deviation	< ± 0.25 (BFSL) / < ± 0.5 (LS)
- Hysteresis.....	< 0.1
- Repeatability (with temperature fluctuations < 10K).....	< ± 0.1
- Long-time stability (in % of the span per year).....	< ± 0.1
- Temperature coefficients (TEMPCO) in the compensated temperature range 0...80°C (in % of the span per 10 K)	
- greatest TEMPCO of the zero point	< ± 0.2
- greatest TEMPCO of the span	< ± 0.2
Materials (wetted parts)	stainless steel (303S22); ceramics; FPM (Viton)
Housing material	stainless steel (304S15); stainless steel (316S12); PBTP (Pocan); PEI; FPM (Viton)
	in addition PTFE for PN2209, PN2223, PN2224, PN2226, PN2227, PN2228
Protection PN2220, PN2221, PN2222.....	IP 67
Protection PN2209, PN2223, PN2224, PN2226, PN2227, PN2228.....	IP 65
Protection class	III
Insulation resistance [MΩ]	> 100 (500 V DC)
Shock resistance [g]	50 (DIN / IEC 68-2-27, 11ms)
Vibration resistance [g]	20 (DIN / IEC 68-2-6, 10 - 2000 Hz)
Switching cycles min.	100 million
Operating temperature [°C]	-25 ... +80
Storage temperature[°C].....	-40 ... +100
Medium temperature [°C]	-25 ... +80
EMC EN 61000-4-2 ESD:	4 / 8 KV
EN 61000-4-3 HF radiated:	10 V/m
EN 61000-4-4 Burst:	2 KV
EN 61000-4-5 Surge:	0.5 / 1 KV
EN 61000-4-6 HF conducted:	10 V

UK

¹⁾ to EN50178, SELV, PELV

²⁾ all indications are referred to a turn down of 1:1

12.1 Setting ranges

		SP1 / SP2		rP1 / rP2		ASP		AEP		ΔP
		min	max	min	max	min	max	min	max	
PN2209	PSI	-14.3	14.5	-14.4	14.4	-14.4	7.3	-7.2	14.5	0.1
	inH ₂ O	-396	401	-399	398	-400	201	-199	401	1
	inHg	-29.1	29.5	-29.4	29.3	-29.4	14.8	-14.6	29.5	0.1
	mbar	-988	1000	-996	992	-996	500	-496	1000	4
	kPa	-98.8	100	-99.6	99.2	-99.6	50.0	-49.6	100	0.4
PN2220	PSI	60	5800	30	5770	0	4350	1450	5800	10
	bar	4	400	2	398	0	300	100	400	1
	MPa	0.4	40.0	0.2	39.8	0.0	30.0	10.0	40.0	0.1
PN2221	PSI	30	3625	15	3610	0	2720	905	3625	5
	bar	2.0	250.0	1.0	249.0	0.0	187.5	62.5	250.0	0.5
	MPa	0.20	25.00	0.10	24.90	0.00	18.57	6.25	25.00	0.05
PN2222	PSI	12	1450	6	1444	0	1088	364	1450	2
	bar	0.8	100.0	0.4	99.6	0.0	75.0	25.0	100.0	0.2
	MPa	0.08	10.00	0.04	9.96	0.00	7.50	2.50	10.00	0.02
PN2223	PSI	-11.5	362.5	-13.0	361.0	-14.5	272.0	76.0	362.5	0.5
	bar	-0.80	25.00	-0.90	24.90	-1.00	18.75	5.25	25.00	0.05
	MPa	-0.08	2.50	-0.09	2.49	-0.10	1.88	0.53	2.50	0.01
PN2224	PSI	-12.8	145.0	-13.6	144.2	-14.6	105.2	21.8	145.0	0.2
	bar	-0.88	10.00	-0.94	9.94	-1.00	7.26	1.50	10.00	0.02
	MPa	-0.088	1.000	-0.094	0.994	-0.100	0.726	0.150	1.000	0.002
PN2226	PSI	-1.50	36.25	-1.65	36.10	-1.80	27.20	7.25	36.25	0.05
	bar	-0.11	2.50	-0.12	2.49	-0.13	1.88	0.50	2.50	0.01
	kPa	-10.5	250.0	-11.5	249.0	-12.5	187.5	50.0	250.0	0.5

ΔP = increments

		SP1 / SP2		rP1 / rP2		ASP		AEP		ΔP
		min	max	min	max	min	max	min	max	
PN2227	PSI	-0.68	14.50	-0.74	14.44	-0.74	10.88	3.64	14.50	0.02
	inH2O	-18.5	401.5	-20.0	400.0	-20.0	301.0	100.5	401.5	0.5
	mbar	-46	1000	-50	996	-50	750	250	1000	2
	kPa	-4.6	100.0	-5.0	99.6	-5.0	75.0	25.0	100.0	0.2
PN2228	inH2O	-4.2	100.4	-4.6	100.0	-5.0	75.4	20.2	100.4	0.2
	mmWS	-105	2550	-115	2540	-125	1910	510	2550	5
	mbar	-10.5	250.0	-11.5	249.0	-12.5	187.5	50.0	250.0	0.5
	kPa	-1.05	25.00	-1.15	24.90	-1.25	18.75	5.00	25.00	0.05

UK

ΔP = increments

13 Factory setting

	Factory setting	User setting
SP1	25 % VMR*	
rP1	23 % VMR*	
OU1	Hno	
OU2	I	
SP2	75 % VMR*	
rP2	73 % VMR*	
ASP	0 PN2209: -14,4 PSI	
AEP	100 % VMR*	
COF	0	
dS1	0.0	
dr1	0.0	
dS2	0.0	
dr2	0.0	
P-n	PnP	
dAP	0.06	
dAA	0.10	
diS	d2	
Uni	PSI / inH2O	

* = the indicated percentage of the final value of the measuring range of the corresponding sensor in PSI / inH2O is set (for PN2209 the percentage of the span).

VMR = final value of the measuring range

More information at www.ifm.com