

Missing Parts? Assembly Questions?

Call us at 1-866-816-3822 or email help@regencyof.com for immediate assistance.

REGENCY

RGS
FURNITURE

MUDSXXXXXXXXX
Regency Fusion U-Shaped
Desk Shell

IO-UDSXXXXXXXXX
ION U-Shaped
Desk Shell

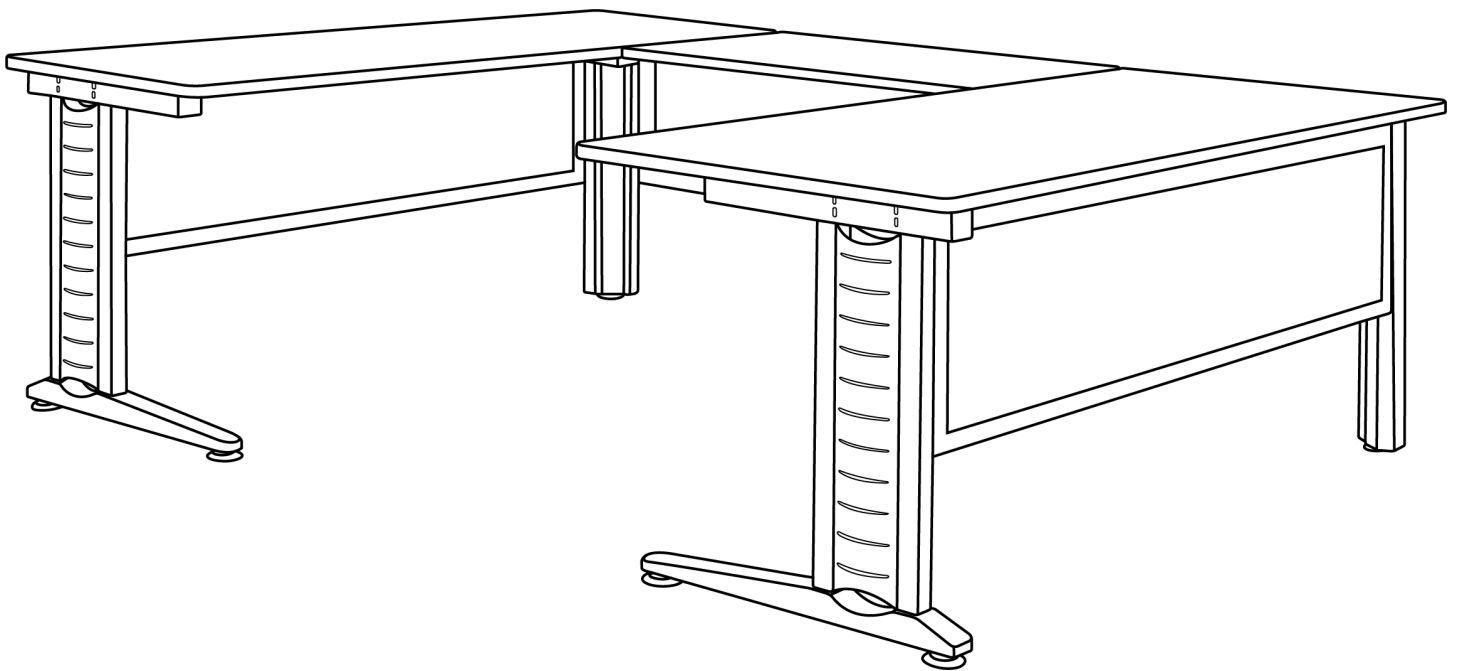

IMPORTANT NOTICE:

Place all wooden parts on a clean and smooth surface such as a rug or carpet to avoid scratching the parts.
Check to be sure that you have all parts and hardware.
Remove all wrapping materials, including staples & packing straps before you start to assemble.
Keep all hardware parts and packaging out of reach of children.
Two person assembly recommended.

Product Care and Usage

Thank you for choosing Regency.

This piece of furniture was manufactured by Regency Seating Inc. With minimal care, your furniture will provide you years of quality service. Your satisfaction is important to us. If you need assistance with any of the below instructions, please contact our customer service department at 866-816-9822 or email us at customerservice@regencyof.com.

General

Your furniture should be dusted frequently using a soft, dry, lint-free cloth, dusting with the direction of the wood grain. Do not use chemicals or abrasive materials to clean surfaces. Regency also recommends the use of desk pads/ mouse pads for high use areas to protect finishes.

Care of Laminate/ Wood/ Veneer Surfaces

Gently wipe the surface to remove any surface dust. Clean with a damp cloth and dry with a lint-free cloth. Do not use furniture polish that contains waxes and oils. Do not use bleach-based cleaners on laminate as it may cause discoloration. While laminate is durable and easily cleaned, avoid using hard bristle brushes which may scratch the laminate surface. Avoid sliding objects over the surface to prevent scratching. The use of coasters is recommended to prevent stains from liquids.

Care of Metal Surfaces

Wipe smooth powder coat finishes and textured metals with a damp cloth. For stubborn stains and grease marks, use soap and water.

Care of Leather/ Vinyl Surfaces

Dust only with a clean, dry, lint-free cloth. Do not use polish, wax, or liquid cleaner.

Care of Fabric Surfaces







Regularly clean your fabric with a vacuum or light brush. For spills, use a damp sponge to blot area. Follow up by blotting with a dry, clean towel. Let air dry. Do not rub or scrub. Heat should never be used when cleaning spills or stains. It can cause stains to set and become permanent.

Care of Plastic/ Polypropylene Surfaces

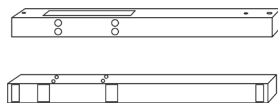
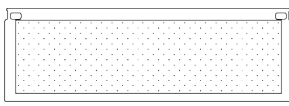
Clean with a mild soap-and-water solution applied to a clean, lint-free cloth. Gently wipe the surface to remove any surface dust. Wipe dry with a new, clean, lint-free microfiber cloth

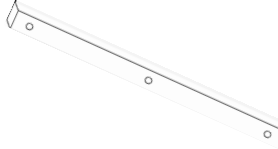
Care of Hardware

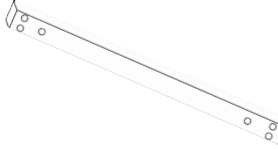
Regularly tighten all nuts, bolts and fasteners. Inspect all joints and fittings to be sure that all are secure. Check and report missing hardware or loose joints.

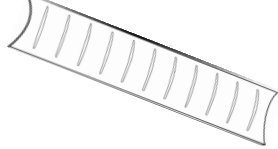
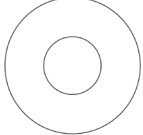
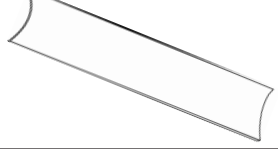
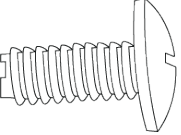
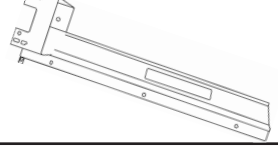
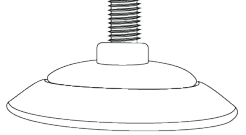
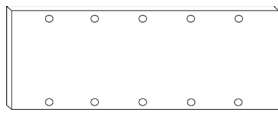
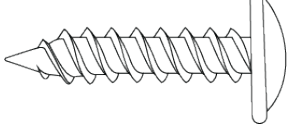
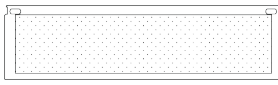
#	Part	Qty	Image	#	Part	Qty	Image
A	Top Bracket	2		J	Short Modesty	2	
B	Foot Bracket	2		K	30" Deep Long Table Top	1	
C	Back Support	2		L	Short Table Top	1	
D	Front Support	2		M	24" Deep Long Table Top	1	
E	Exterior Leg Cover	2		N	Washers	12	
F	Interior Leg Cover	2		O	Bolts	20	
G	Corner Leg	2		P	Glides	6	
H	Flat Bracket	2		Q	Screws	38	
I	Long Modesty	1					

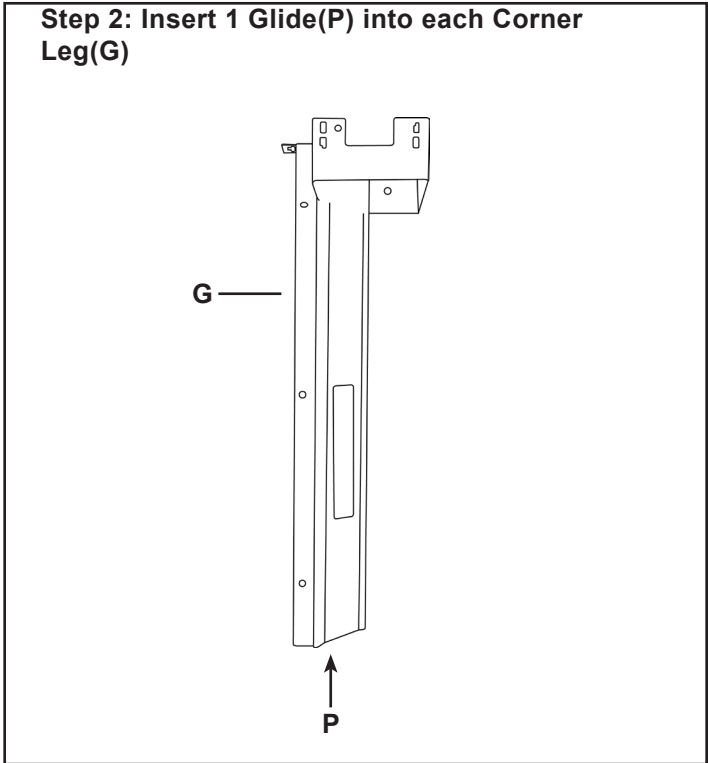
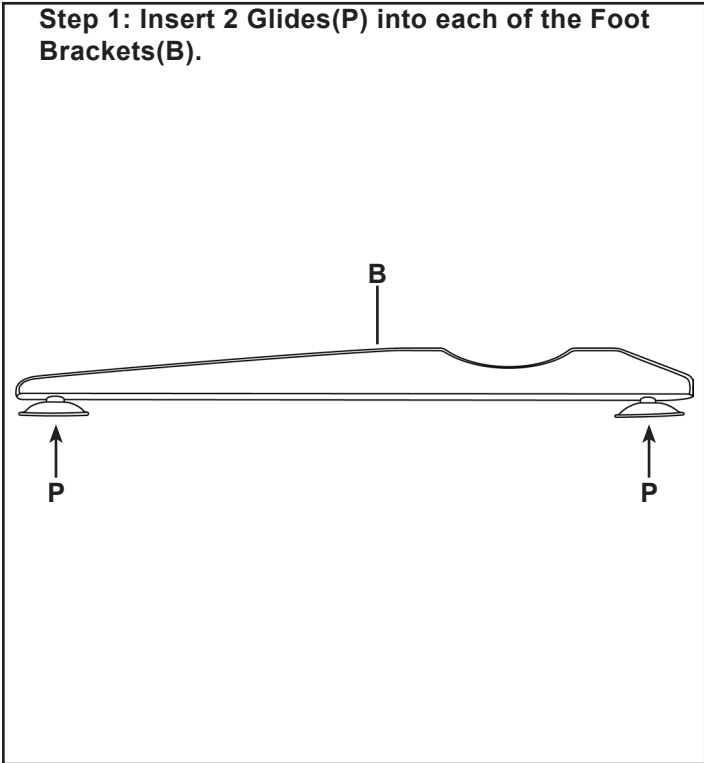

BEFORE STARTING STEP 3A-B, NOTE THE HOLE PLACEMENT IN FIGURE 1.
The set of three holes on each of the Front Supports and Back Supports should face in towards one another.

Step 3A: Assemble Legs by inserting back Supports(C) into each Foot Bracket(B).
****NOTE: Modesty Holes on Back Support should face interior side as shown below.****

Step 3B: Now insert the Front Supports(D) into each Foot Bracket(B). Then insert each Top Bracket(A) into the Front Supports(D) and Back Supports(C). Finally, attach Foot Brackets(B) and Top Brackets(A) to the Front Supports(D) and Back Supports(C) with 4 Bolts(O) per leg.
****NOTE: Do not tighten bolts until all bolts have been started.****

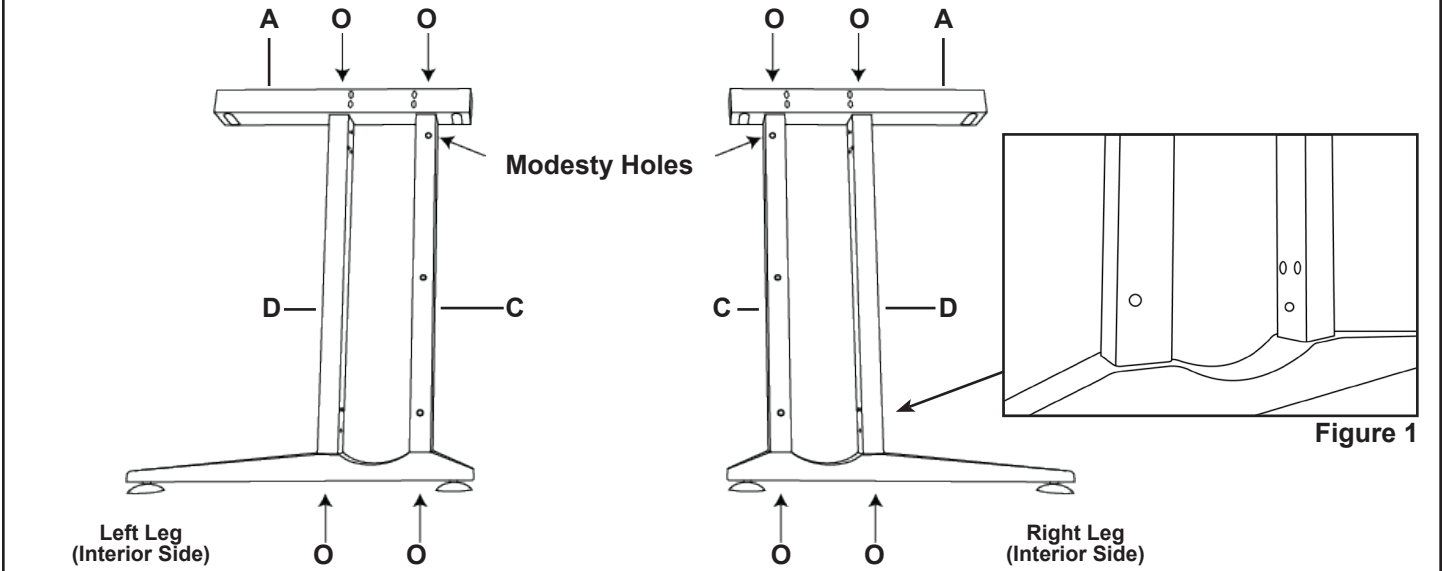

Step 4A: Snap the Interior Leg Cover(F) into Back Support(C) and Front Support(D) using a rubber mallet.

****NOTE:** Interior Leg Cover is installed on the side with the modesty holes.**

Step 4B: Snap the Exterior Leg Cover(E) into Back Supports(C) and Front Support(D) using a rubber mallet. The assembled legs will now be referred to as End Legs.

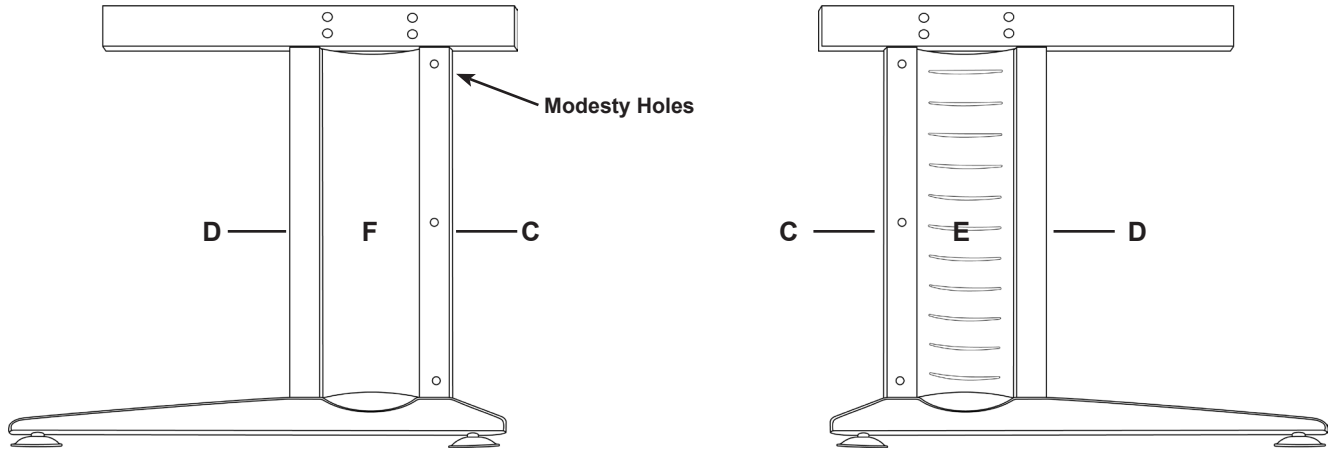

NOTE: PRODUCT IS REVERSIBLE.
THE FOLLOWING STEP INCLUDES BOTH RIGHT AND LEFT ORIENTATIONS.
THE REMAINING STEPS ARE THE SAME NO MATTER THE ORIENTATION.

Step 5: Choose your desk orientation and place the 30” Deep Long Table Top(K), 24” Deep Long Table Top(M), and Short Table Top(L) on a clean flat surface with desired table finish face down so the sides of the three tops are flush on the long “connecting” side. Connect an End Leg to one Short Modesty(J) with 2 Bolts(O) and 2 Washers(N) ensure the lip of the modesty is facing toward the Short Top(M). Then Connect the opposite end of the Short Modesty(J) to 1 Corner Leg(G) with 2 Bolts(O) and 2 Washers(N) as shown below. Be sure there is no gap between the modesty and the top. If so, loosen Bolts(O) and adjust. **DO NOT ATTACH TO THE TOPS.**

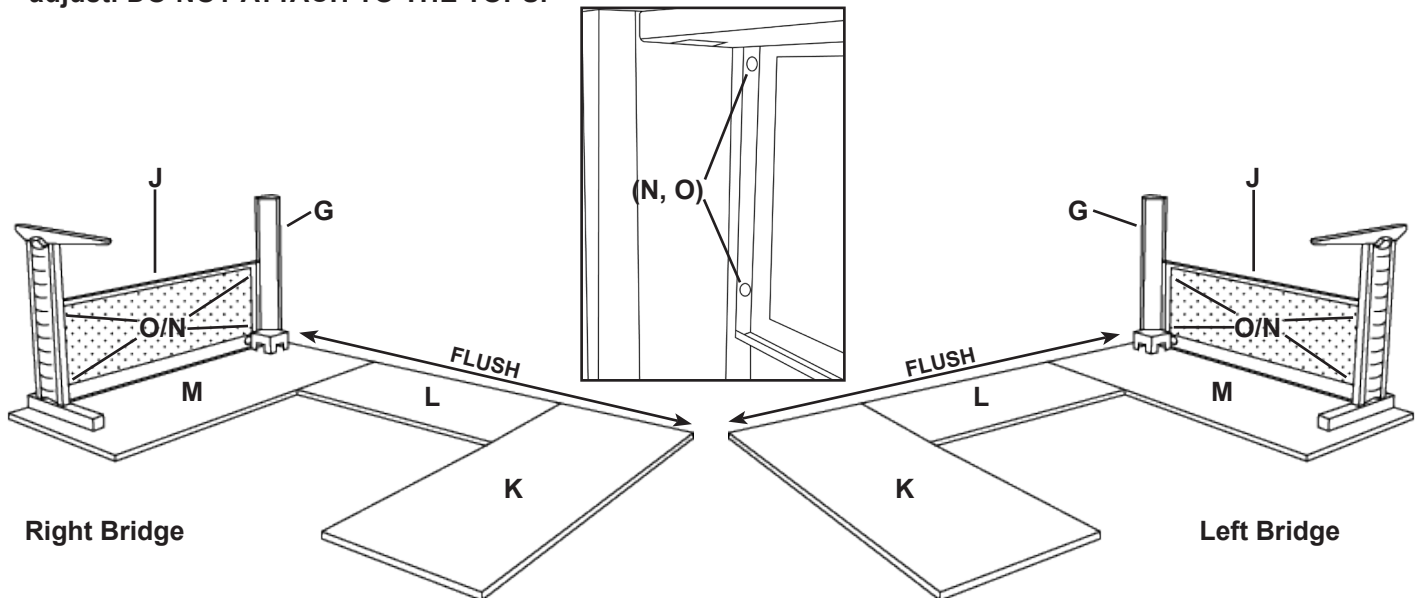

Step 6A: Attach Long Modesty(I) to existing Corner Leg(G) and add second Corner Leg(G) with 1 Bolt(O) and 1 Washer(N) on each leg. ONLY HAND TIGHTEN AS THIS WILL BE REMOVED LATER.

Step 6B: Connect the second End Leg to the remaining Short Modesty(J) and Corner Leg(G) with 4 Bolts(O) and 4 Washers(N). TIGHTEN STEP 6B BOLTS.

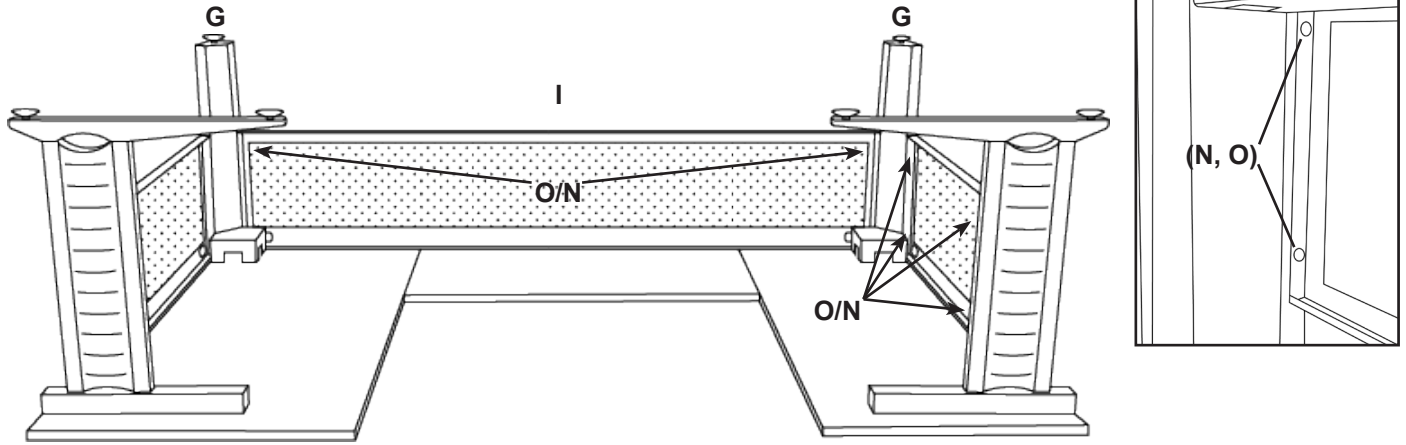

Step 7: Square the legs and modesties using a tape measure. Arrange all metal components so there is an equal margin on the top/bottom & left/right sides. Connect the End Legs and Corner Legs(G) to the tops as figure 1 and 2 depict. For extra support connect the Short Modesties(J) to the table top using 2 Screws(Q) each modesty.

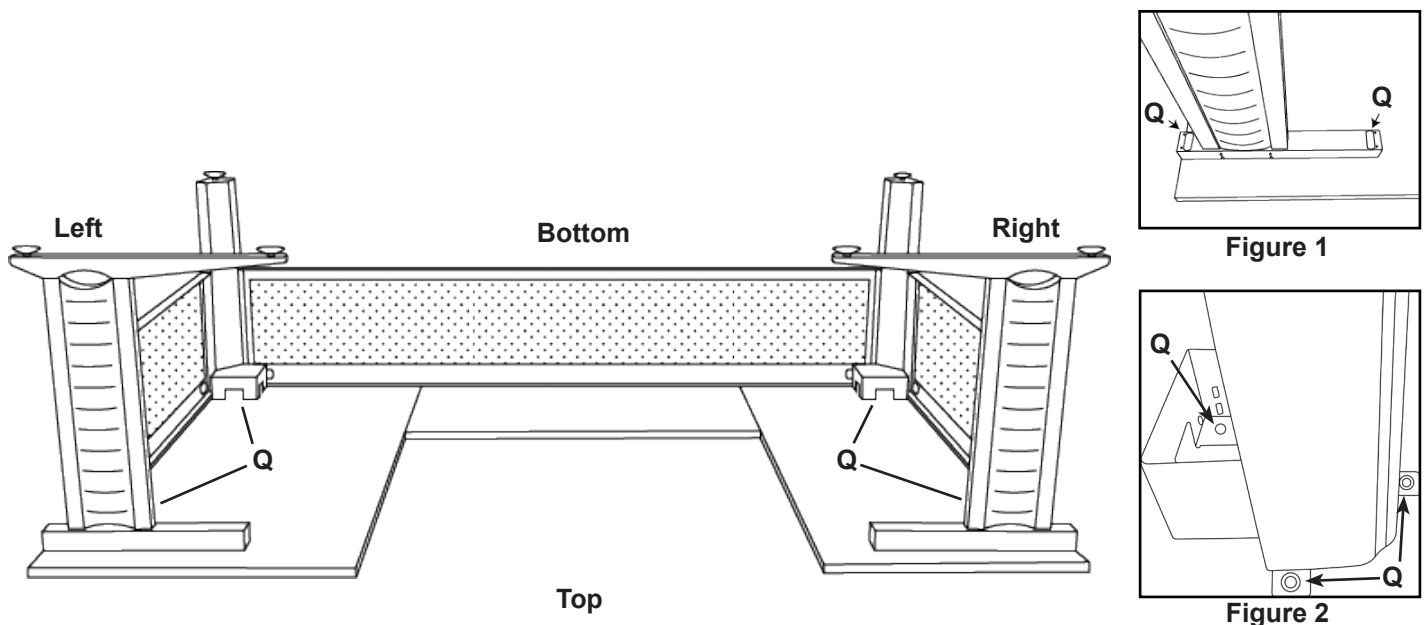

Step 8A: Place 2 Flat Brackets(H) evenly spaced over the Short Table Top(L) connections with the two Long Table Tops. Using 12 Screws(Q) attach the Flat Brackets(6 screws each) on the LONG TABLE TOP SIDE ONLY as depicted in the image below.

Step 8B: Remove the Long Modesty(I) from the Corner Legs(G) and flip over the Desk/Credenza so they are standing upright and in the position you would like the "U" group to be. Be sure to leave space for the removed modesty and short top.

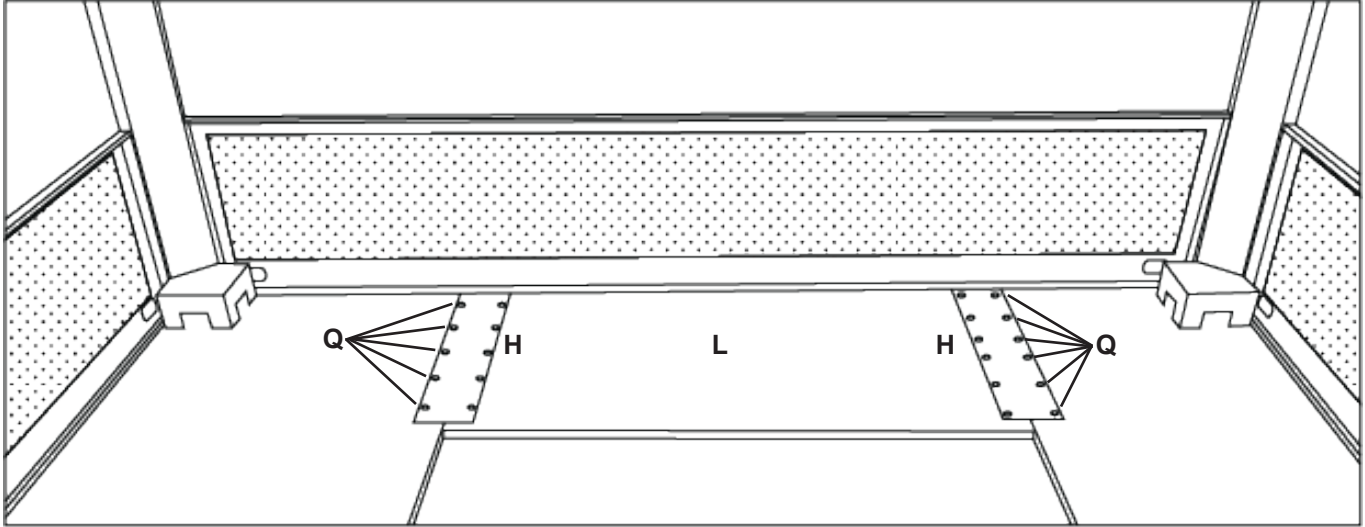

Step 9: Reconnect the Long Modesty(I) to the Corner Leg(G) using 2 Bolts(O) and 2 Washers(N) on each leg. Place the Short Top(L) in position and attach to Flat Brackets(H) using 12 Screws(Q), 6 screws each bracket. For extra support connect Modesty(I) to the table top using 2 Screws(Q).

**Thank you for your purchase...
Please be sure to leave a review with your retailer!
Satisfied with your purchase? Be sure to leave us a review.
We appreciate your feedback!**



Regency Facebook: @RegencyOffice
RGS Facebook: @RGSFurniture



Regency Instagram: regencyof
RGS Instagram: @rgs_furniture



Regency Twitter: @RegencyOFA
RGS Twitter: @RGSFurniture