

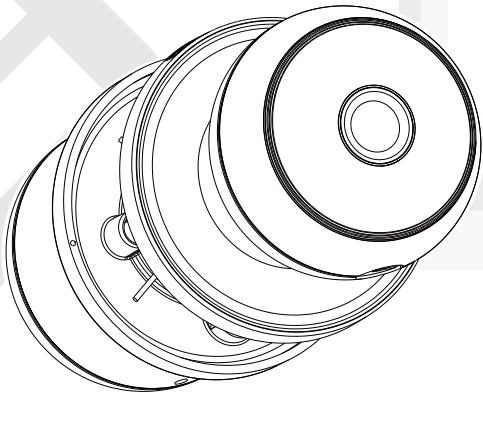

GEEK TECHNOLOGY CO., LTD
120 US Route 46,
Parapony, NJ 07054,
Toll Free:
1-844-801-8880

GeekTale

User Manual
Model No.: K11



IMPORTANT: Read the instructions carefully before operating the equipment and keep them for future reference.

WELCOME

GeekTale bids you welcome to a world of smart home devices, smart locks, and smart surveillance. We at GeekTale strive to explore and develop the smart home industry for the good of all. We use cutting-edge technologies to develop products fit and ready for the market.

Please visit our website www.geektechnology.com. Before installing, please scan the QR codes to watch our easy step-by-step installation video. If you have questions regarding the installation process, please contact us by mail service_lock@geektechnology.com or by phone 1-844-801-8880.



Scan the QR code for more Geek Tale Products

PRODUCT DIMENSIONS

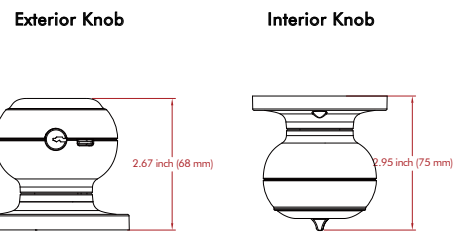

2

PRODUCT DESCRIPTION

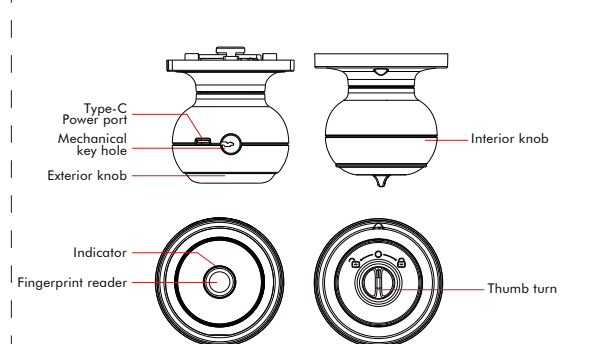

Indicator Light

- Add fingerprint**
Blue light: The fingerprint light turns to blue as to indicate the lock is ready to add fingerprint.
- Fingerprint, mobile phone APP unlock**
Green light: Success (the buzzer beeps once, and the fingerprint light flashes green to indicate).
Red light: Failed (the buzzer beeps twice, the fingerprint light flashes red to indicate).
- Low power**
Green+red light: When the lock is unlocked with fingerprint or mobile APP the buzzer beeps once and fingerprint light flash green and red.

3

INCLUDED IN THE BOX

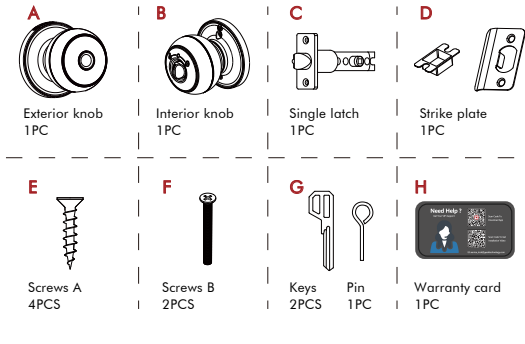

4

ASSEMBLY DIAGRAM

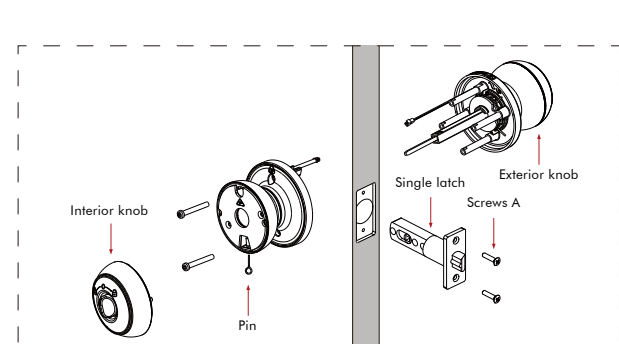

5

CHECK THE DOOR'S DIMENSIONS

- Step 1: Measure to confirm that the door is between 1 3/8"-2 1/8" (35mm ~54mm) thick.
- Step 2: Measure to confirm that the hole in the door is 2 3/8" (54mm).
- Step 3: Measure to confirm that the hole in the door is either 2 3/8" or 2 3/4" (60-70mm).
- Step 4: Measure to confirm that the hole in the door edge is 1" (25 mm).

Note: If you have a new door, please drill the holes according to Drill Template.

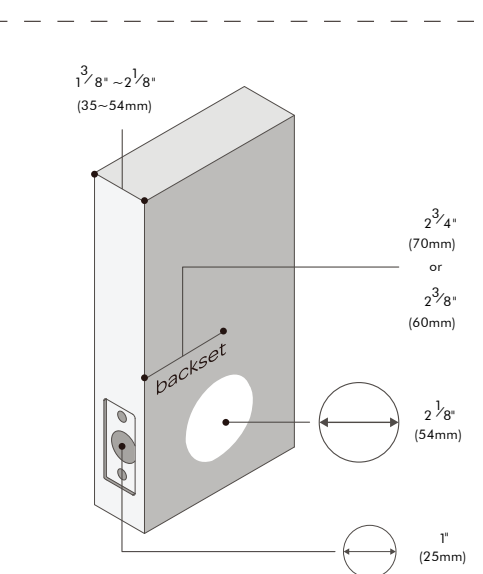

6

INSTALLING LATCH AND STRIKE PLATE

- Please install the latch into the door, pay attention that the direction of the latch is opposite to the direction of closing the door, for example, if the door opens outwards, the latch should face inward; if the door opens inward, the latch should face outward.
- Install the strike into the door frame, make sure the latch can go into the strike smoothly.

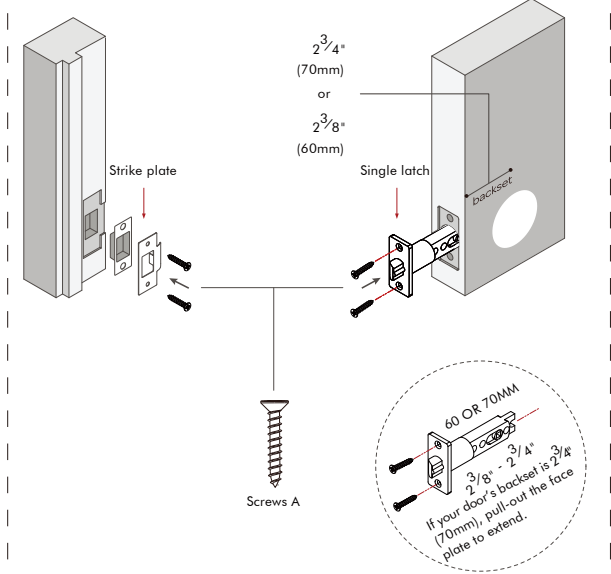

7

INSTALLING EXTERIOR KNOB

Install the Exterior Knob, insert the spindle and the standoffs into the corresponding holes of the single latch.

Note: DO NOT CLOSE THE DOOR until the door lock is fully installed.

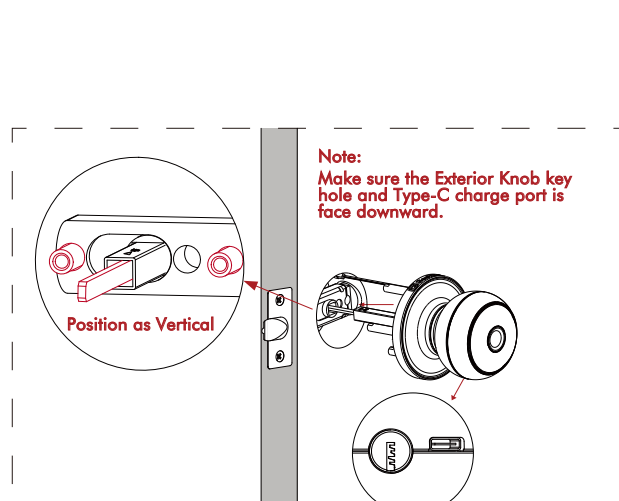

8

INSTALLING INTERIOR KNOB

- Step 1**
Pull out the interior knob with pin.
- Step 2**
Please connect the cables and hide in the door as photo.

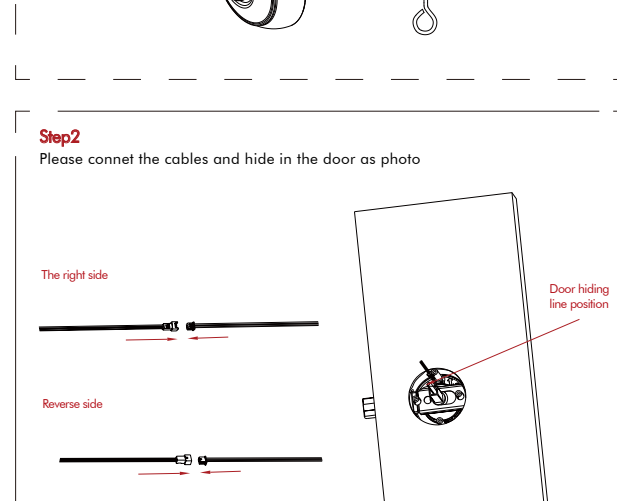

9

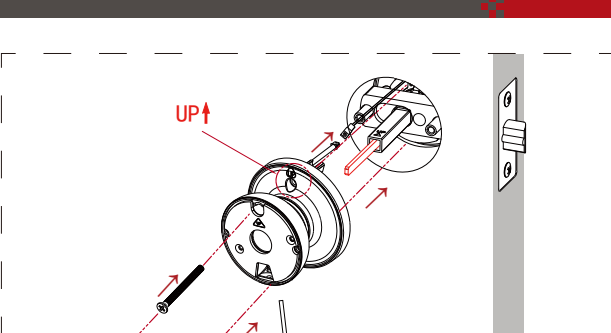

10

HOW TO UPGRADE K11-B2 TO K11-B1?

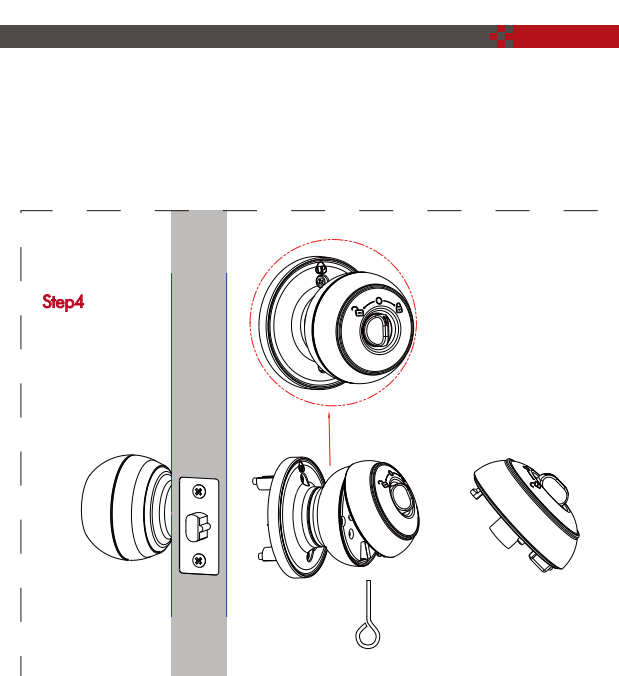

Now connecting the Battery Cover into the interior knob. PLEASE MAKE SURE YOU TURN THE THUMB TURN INTO VERTICAL POSITION LIKE IN THE DIAGRAM. MAKE SURE THE THUMB TURN IS ALIGN with the up hole on the interior knob body like in the diagram. Once everything is confirmed, push in the knob until you hear a click sound.

11

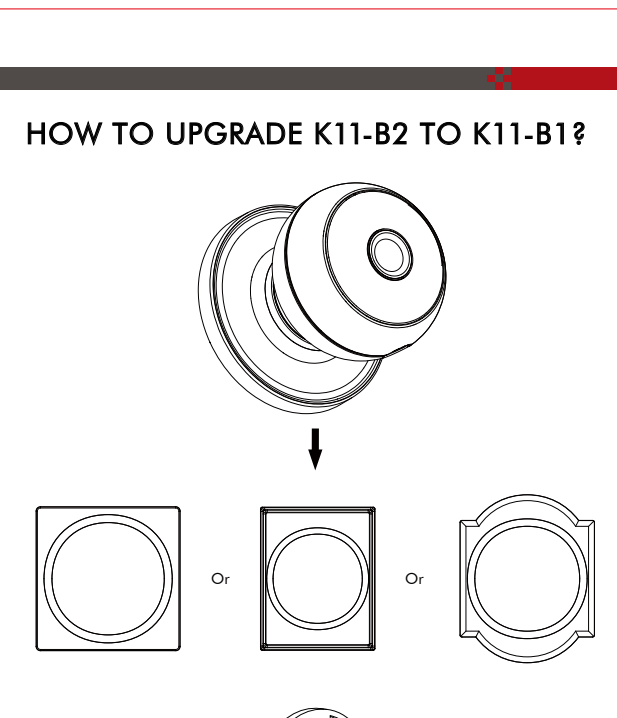

Place our decoration plate (need to buy on our Amazon shop) behind the exterior panel, you will get a complete lock K11-B1.

12

DOWNLOAD THE GEEKSMART APP

- App Download Instructions**
A. Scan the QR code on the right you can use Android and iOS to download the APP.
B. Android version software can be downloaded in the Google Play store. Search "GeekSmart".
C. iOS version of the software can be downloaded in the iPhone App Store. Search "GeekSmart".
- Register and log in with your E-mail address.**



13

ADDING DEVICE

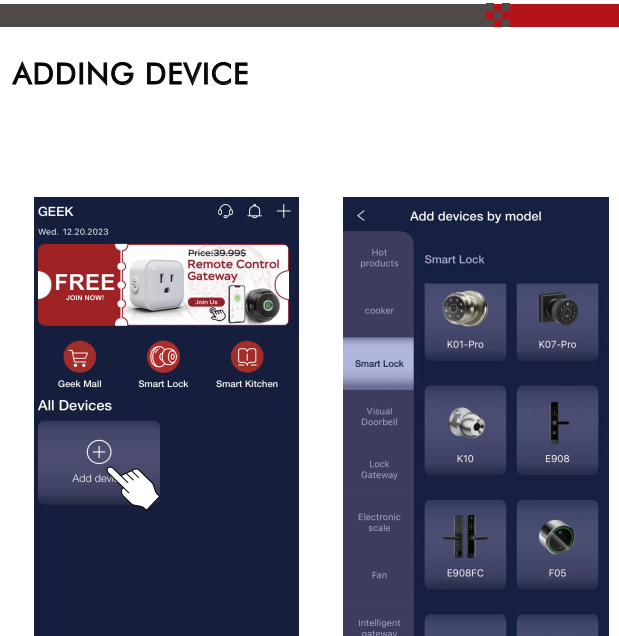

- Tap add device button.
- Continue to follow the instruction on the App interface.

14

HOW TO ADD FINGERPRINT BY GEEKSMART APP

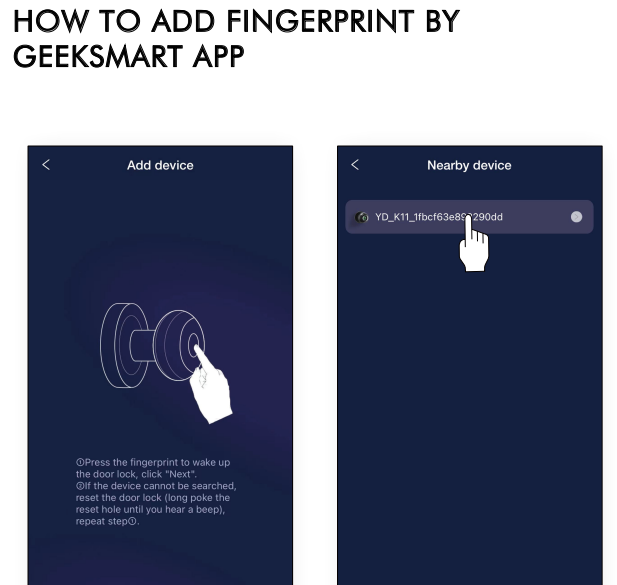

- Select your lock.
- Add complete.

15

HOW TO ADD FINGERPRINT BY GEEKSMART APP

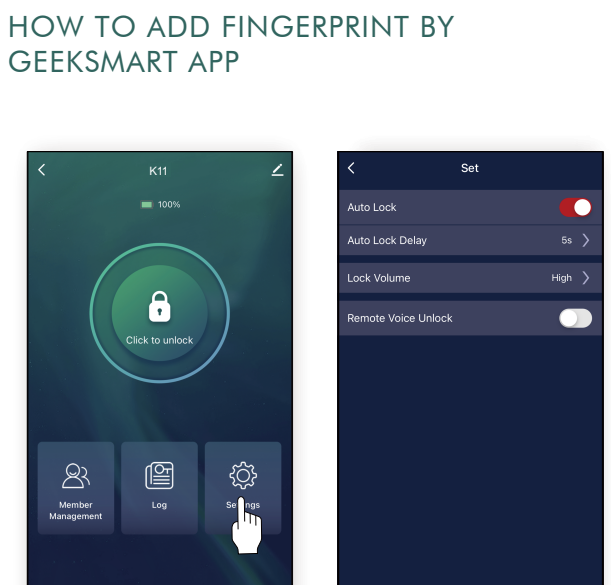

- Click member management.
- Click me.
- Continue to follow the instruction on the App interface.

16

HOW TO ADD FINGERPRINT BY GEEKSMART APP

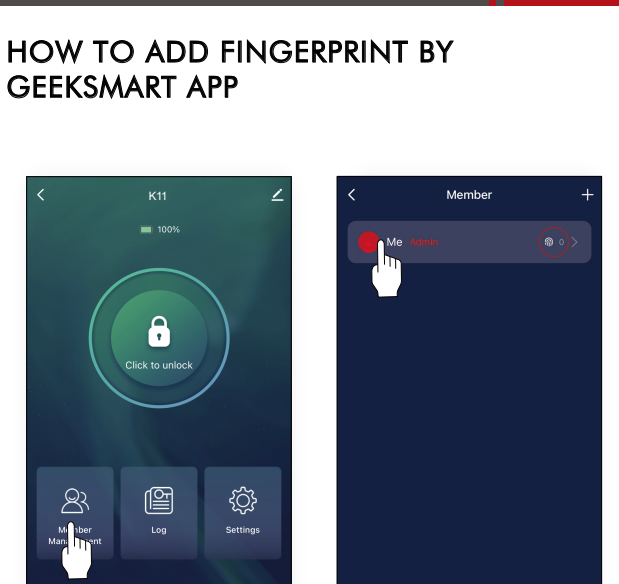

- Click member management.
- Click me.
- Continue to follow the instruction on the App interface.

17

HOW TO DELETE FINGERPRINT BY GEEKSMART APP

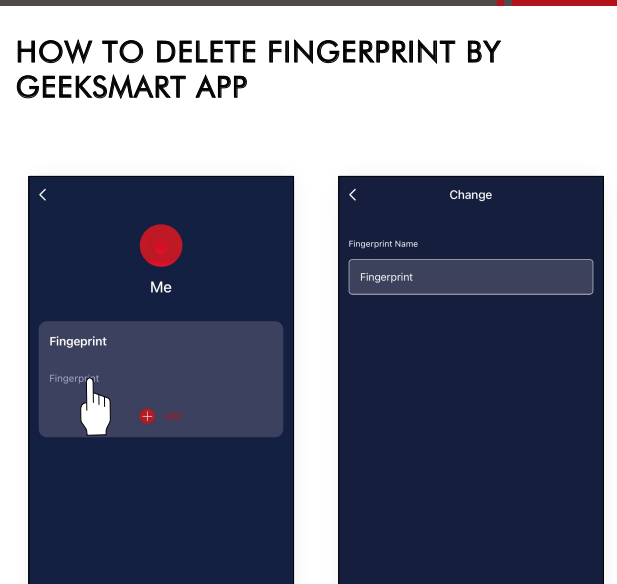

- Tap the fingerprint you want to delete.
- Tap delete.

18

TROUBLESHOOTING

- Q: How to reset the K11?
A: Please select "restore factory setting" or "Delete device" by GeekSmart APP.
A: Turn the interior knob thumb turn to the left and return to the middle position 5 times and turn the thumb turn to the right and return to the middle position 5 times now you will hear a long buzzer that means the reset has been successfully.

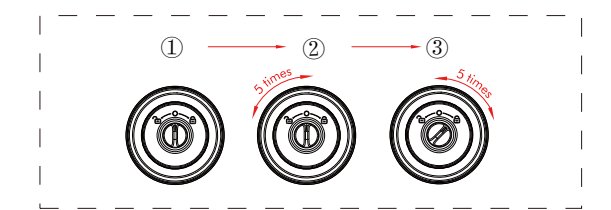

- Q: Does K11 work with third-party accessories such as single performance and stability?
A: It is recommended to use the original accessories for best performance and stability.

- Q: What notification will I receive when the battery is low?
A: After the fingerprint and mobile APP are successfully unlocked (the buzzer beeps once, the fingerprint reader flashes green and then flashes red).
A: When you unlock the device through the mobile App, you will receive a push notification message with low battery warning.
A: The remaining power can provide about 50 times to unlock. Please use the power bank to charge in time.

- Q: How can I unlock K11 if battery runs out?
A: Turn the key 90° to unlock, then turn the exterior knob to unlock the door.
A: Connect a power bank to the knob with type-C cable as to activate for emergency access.

Important Note: Please keep at least one key in secure location elsewhere as an extra precaution.

19

- Q: If I order 3 locks will anyone else have the same keys?
A: Each set of locks is keyed differently.

- Q: Accidentally deleted the lock from the app, what should I do?
A: 1. You delete the lock in the app, but the lock is not emptied. Please RESET the lock.

2. Add again on the GeekSmart APP.

- Q: My Bluetooth won't connect, what should I do?
A: 1. Upgrade to the latest version of the firmware, authorize Bluetooth in the phone settings to allow access to the Geek Smart App.

2. Try to connect again.

3. If the connection is still not smooth, please contact our after-sale service.

- Q: How to enable passage mode?
A: Turn the thumb turn to the left and you will hear a beep sound, at which point the device is in passage mode status (Fig.).



- Q: How to enable security mode?
A: Turn the thumb turn to the right and you will hear a beep sound, at which point the receive is in security mode status (Fig.).



- Q: What is the difference between administrator/user?
A: The first user to add the knob by GeekSmart APP member is administrator, other members are users.

- A: Administrator fingerprint can unlock even in the security mode, but user cannot unlock in the security mode. You can enable or disable in the APP.

20

- Q: How to remove the interior knob?
A: Use the Pin insert to the interior knob hole as shown, pull out the interior knob.

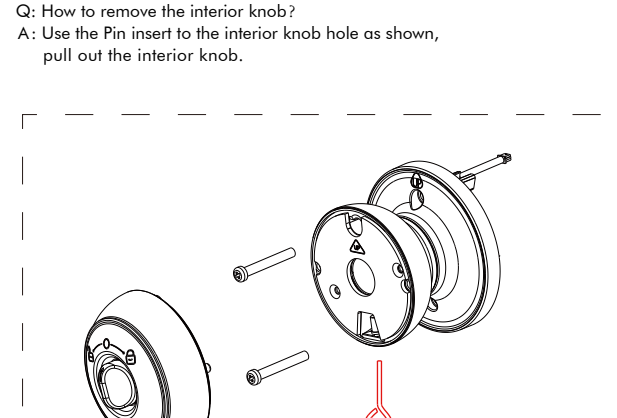

WARNING: K11's Battery charging temperature: 41 F-121 F, please charge the battery in this temperature range!!!!!!

21

SPECIFICATIONS

Technical Parameters		
No.	Name	Parameter Description
1	USB	Type-C/ 5V2A
2	Fingerprints max	50
3	Low power warning	3.5V±0.2
4	Voltage range	3.4V~4.2V
5	Stand-by current	< 90uA
6	Operating Current	<500mA
7	Unlock time	≈1.5 sec
8	Range of working Temperature	23~131 F
9	Door thickness	1 3/8"-2 1/8" (35-54mm)
10	Material	Aluminium alloy+Stainless Steel
11	Power	Lithium battery

22

FCC WARNING

Any Changes or modifications not expressly approved by the party responsible for compliance could void the user's authority to operate the equipment.

Note: This equipment has been tested and found to comply with the limits for a Class B digital device, pursuant to part 15 of the FCC Rules. These limits are designed to provide reasonable protection against harmful interference in a residential installation. This equipment generates uses and can radiate radio frequency energy and, if not installed and used in accordance with the instruction, may cause harmful interference to radio or television reception, which can be determined by turning the equipment off and on, the user is encouraged to try to correct the interference by one or more of the following measures:

- Reorient or relocate the receiving antenna.
- Increase the separation between the equipment and receiver.
- Connect the equipment into an outlet on a circuit different from that to which the receiver is connected.
- Consult the dealer or an experienced radio/TV technician for help.

This device complies with part 15 of the FCC Rules. Operation is subject to the following two conditions: (1) This device may not cause harmful interference, and (2) this device must accept any interference received, including interference that may cause undesired operation.

23