

# MANUAL SCISSOR CART - CART-24-10-M

APPROX WEIGHT: 401.81 lbs.  
 DOES NOT INCLUDE WEIGHT OF POWER OR PACKAGING!!!

\*\*\* ANY ADDITIONS, DELETIONS, OR OMISSIONS MUST BE CORRECTED ON THIS DRAWING AS THIS DRAWING WILL BE CONSIDERED ALL INCLUSIVE \*\*\*

ALL GRAPHICS PROVIDED ARE FOR REFERENCE ONLY. IF CERTAIN DIMENSIONS ARE CRITICAL PLEASE VERIFY THOSE DIMENSIONS WITH YOUR SALESPERSON

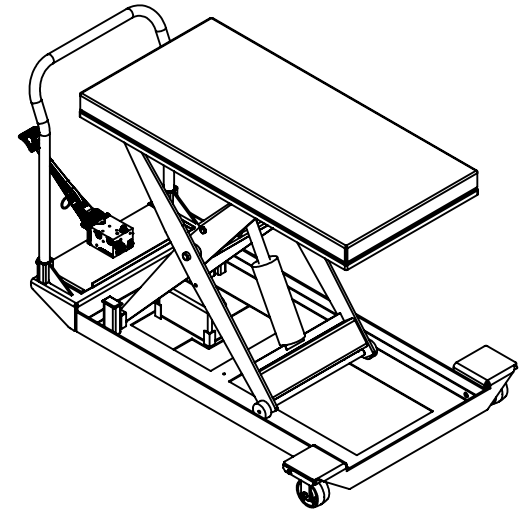
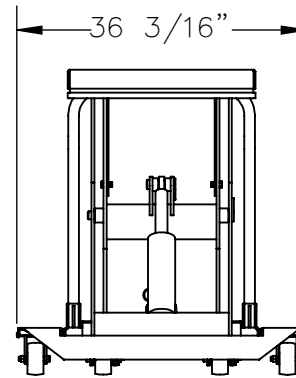
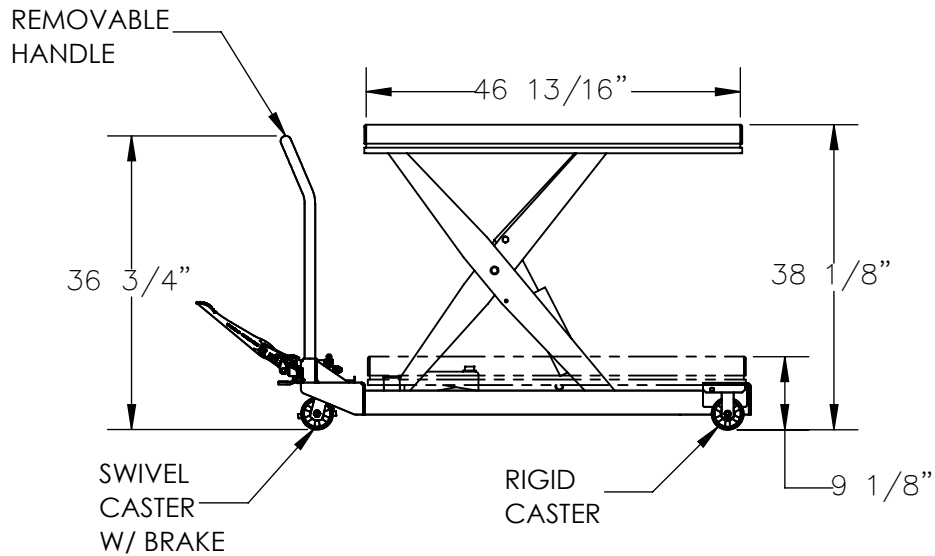
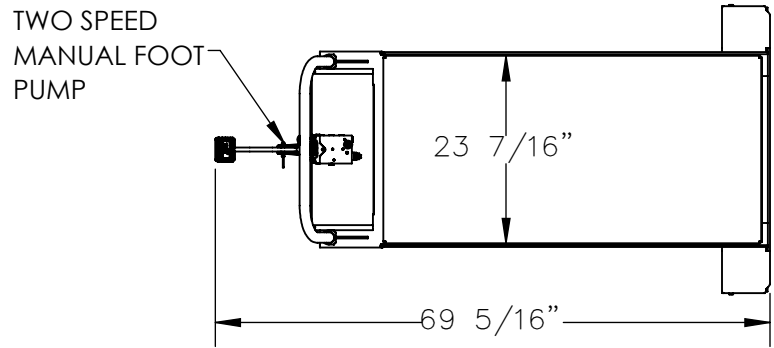

DIMENSION TOLERANCE ± 1/4"

## STANDARD FEATURES

- MODEL NUMBER IS CART-24-10-M
- OVERALL WIDTH IS 36 3/16"
- PLATFORM WIDTH IS 23 7/16"
- OVERALL LENGTH IS 69 5/16"
- PLATFORM LENGTH IS 46 13/16"
- RAISED HEIGHT IS 38 1/8"
- PLATFORM LOWERED HEIGHT IS 9 1/8"
- HANDLE HEIGHT IS 36 3/4"
- CAPACITY IS 1,000 LBS
- CASTERS: TWO 4" X 2" PHENOLIC SWIVEL W/ BRAKE
- TWO 4" X 2" PHENOLIC RIGID
- BASE: DURABLE BAKED IN POWDER COATED BLUE FINISH
- SCISSOR TABLE: DURABLE BAKED IN POWDER COATED YELLOW FINISH

## SPECIAL FEATURES

NONE

<b>A P P R O V A L</b>	I, THE UNDERSIGNED, AGREE THAT THE PRODUCT AS REPRESENTED SATISFIES DESIGN AND DIMENSION REQUIREMENTS. I ALSO ACKNOWLEDGE MY DUTY TO CONFIRM PRODUCT AND INSTALLATION COMPLIANCE WITH ALL APPLICABLE FEDERAL, STATE AND LOCAL REGULATIONS AND STANDARDS.	
	<b>UNITS REQUIRING APPROVAL DRAWINGS OR MODIFIED ARE NON-RETURNABLE</b>	
	[ ] As drawn      [ ] As marked	
	Signed: _____ Date: _____	
Printed Name: _____		
<i>LEAD TIME WILL START UPON RECEIPT OF SIGNED APPROVAL DRAWING</i>		

DISTRIBUTOR'S NAME:		P.O.#
<b>VESTIL MANUFACTURING</b>		X
DRAWN BY: <b>AJS</b>		W.O.#
DATE: <b>12/03/2024</b>		X
REFERENCE: <b>X</b>		SALES: <b>X</b>
QUOTED LEAD TIME: <b>X</b>		FILE NAME:
QUOTE # <b>X</b>		01-007-537