

Made Here. Made Better.



A substantial amount of OSRAM SYLVANIA products sold in NAFTA are assembled or made in the USA. SYLVANIA operates 15 manufacturing facilities, 8 R&D labs, and 2 corporate technology centers right here in the USA. OSRAM SYLVANIA offers a world of money saving opportunities that are made right here at home. We help design a solution that includes energy saving products as well as the latest in lighting controls to reduce energy consumption and ultimately save you money. As experts in LED lighting and design, we

can help your company take full advantage of the latest technologies, which can be customized to your needs. The savings generated from SYLVANIA energy-efficient lighting systems will save you money today and in the years to come. This results in savings you can invest and use to stimulate your business even more.

OSRAM SYLVANIA Leads Sustainability in Lighting

Recognized for our achievements:



20% absolute corporate greenhouse gas emissions reduction in 5 years (exceeded 10% goal)



12.5% product energy intensity reduction in 5 years



10-year ENERGY STAR® Partner of the Year



Member of National Clean Fleets Partnership



Member of USGBC since 2003



Member of EPA SmartWay™ Transport Partnership since 2008



Platinum Sponsor of Green Parking Council since 2012

US DOE Workplace Charging Challenge Partner

OSRAM SYLVANIA is a sustainability leader, focusing on reducing environmental impact of products and processes for our company and for our customers.

Lead-Free Manufacturing

- Fluorescent manufacturing in Versailles, Kentucky
- Electronic ballast manufacturing

Made in the U.S.A.

- OSRAM SYLVANIA operates manufacturing and assembly facilities in the United States
- All NAFTA facilities ISO 14001 certified

www.sylvania.com/sustainability

OSRAM SYLVANIA: THE LEADER IN ENERGY-SAVING HID LAMPS

UNDERSTANDING HIGH INTENSITY DISCHARGE LIGHTING

A brief description of the catalog format and related terminology will assist the reader in understanding the information presented in this section.

All product families are listed in ascending wattage, followed by alphabetical bulb designation to simplify lamp identification. Performance ratings are based on tests conducted under controlled conditions on AC circuits with auxiliary equipment meeting current published ANSI specifications.

Lamp performance under typical service conditions may vary from rated values. Ratings and specifications are subject to change without notice.

ANSI CODE

This is a unique code that describes the class and the electrical characteristics of the lamp and ballast as well as the fixture requirements. The code is developed and assigned by the American National Standards Institute (ANSI). It is intended to aid in matching the lamp to both the correct ballast and to a luminaire with the required features. The ANSI CODE consists of type of lamp (S = HPS, H = Mercury, M = Metal Halide, L = LPS, C = Ceramic Metal Halide), followed by the ballast number, and for metal halide and Ceramic metal halide lamps followed by the fixture requirement (O, E, S, F).

The emergence of electronic ballasts to operate metal halide lamps has produced additional need to separate the lamp designation of quartz and ceramic metal halide lamps, as there can be some important differences in system performance. Therefore the C lamp designation from NEMA has been introduced going forward for future differentiation of ceramic metal halide lamps and they will begin to be labeled accordingly.

ARC LENGTH

Arc length is the dimension of the arc discharge measured from one electrode tip to the other. This is useful for optical design of reflectors and affects fixture efficiency.

AVERAGE RATE LIFE (HOURS)

The average life of a lamp is based on vertical operation (unless otherwise noted) of representative lamps operated under controlled conditions of at least 10 hours per start (except for M1500 and BRITELINE® lamps, which are based on 5 hours per start). Average life is defined as the total operation hours at which 50% (Median) of any group of lamps is still operating (except for most High Pressure Sodium and Mercury lamps, for which 65% of the lamps are operating at the end of life denoted by a "+" next to the life rating). Variations in operating conditions such as bulb and base temperatures and line voltage can also affect lamp life.

Regular operation of lamps with off times less than the hot restrike time will shorten lamp life. For hot restrike values of specific lamp types, please refer to the SYLVANIA Metal Halide Lamp Specification Guide.

Operating cycles shorter than 10 hours per start will reduce lamp life as follows:

- 5 hours / start – Approximately 75% of rating
- 2.5 hours / start – Approximately 55% of rating
- 1.25 hours / start – Approximately 40% of rating

BASE

Most SYLVANIA HID lamp bases for general lighting are made of corrosion-resistant brass with special lubricant to provide easy removal at end of lamp life. See page 123 for all base illustrations.

GU6.5 – Bipin bases are used on the smallest HID lamps and convenient twist & lock feature provides secure installation.

G8.5 – Durable bipin bases have special center presses that secure lamps in the socket.

G12 – Ceramic bipin bases are used on T6, T7.5 single ended lamps.

E26 Medium – Medium (MED) bases are used on lamps in E17 bulbs and are limited to 175W maximum.

E26 Medium Skirted – Medium skirted (Med Skt) bases consist of a medium brass base with a skirt, which is mechanically connected to a PAR38 bulb.

E39 Mogul – All (MOG) bases are embossed with letters and numbers representing months and years. The date of installation can be recorded by marking the letter of the current month and the number that coincides with the last digit of the current year.

EX39 Exclusionary Mogul Base – Exclusionary Mogul bases (EXCL MOG) are bases used on metal halide lamps having shrouded arc tubes, permitting them to be used in open fixture applications. These bases are compatible with exclusionary or standard mogul sockets.

E39 POM – Position Oriented Mogul (POM) bases are used on lamps designed to operate only in the horizontal position and require a special POM socket. A pin located on the base engages in a slot within the POM socket ensuring proper operating position of the lamp within the fixture.

Rx7s / R7s Recessed Single Contact – SYLVANIA double-ended HID lamps with recessed single contact (RSC) bases have silver plated contacts to provide maximum electrical contact.

BULB

Each bulb description consists of a letter to indicate bulb shape, followed by numbers that indicate maximum bulb diameter in 1/8 inch increments. For example, a BT37 bulb is a blown shape with a tubular top, 3-7/8 of an inch or 4-5/8 inches in diameter. Illustrations of bulb shapes are shown on page 123.

Although SYLVANIA HID bulbs are made of glass designed to resist thermal shock in normal applications, they must be shielded from direct contact with liquids, such as rain, during operation to avoid bulb breakage.

COLOR RENDERING INDEX (CRI)

Color Rendering Index (CRI) is an international scale (numbering system) up to 100 indicating the relative color rendering quality of a light source when compared to a standard reference light source of the same chromaticity (color temperature). The CRI expresses the degree to which colors will appear "familiar" or "natural" under the light source selected. In general, the higher the CRI number, the better the color rendering properties of the light source being measured. The color rendering index of any two like sources should only be compared if those sources have the same correlated color temperature (CCT).

CORRELATED COLOR TEMPERATURE (CCT)

The correlated color temperature of a light source, expressed in Kelvin (K), is a means of describing the appearance or chromaticity of the source. The correlated color temperature of the light source contributes to the visual appearance of the lighted space. "Warm" light sources have a low color temperature (2000-3000K) and feature more light in the red/orange/yellow range. Light with a higher color temperature (>4000K) features more blue and is referred to as "cool".

With new installations, or group relamps, all color performance evaluations should be made after at least 100 hours of operation (at recommended operating cycles) to allow the lamps to stabilize. Additional changes in chemistry within the arc tube over the life of the lamp may also cause the color temperature to shift as the lamp gets closer to the end of its rated life. To minimize color variation within an installation, it is recommended that HID lamps be group relamped and run on equal operating cycles.

DIMMING HID

Most SYLVANIA HID products can be dimmed on stepped 0- 10 volts, bi-level dimming systems provided specific guidelines are followed. Generally, most Metalarc® metal halide lamps can be dimmed down to 50% of rated wattage depending on the lamp type and operating position. LUMALUX® high pressure sodium lamps can also be dimmed down to 50% of rated wattage. In addition to lower light output, HID lamps may shift in overall color and exhibit a lower color rendering index (CRI) when operated in a dimmed mode. Some restrictions apply to both the operation of the ballast and lamp. For more information on dimming, please reference NEMA guidelines or contact a SYLVANIA representative.

FIXTURE REQUIREMENT

Developed by the American National Standard Institute (ANSI), the fixture requirement code describes the type of fixture required for each lamp type. See lamp warnings for additional information and proper operating instructions.

Operating cycles shorter than 10 hours per start will reduce lamp life as follows:

E = Lamps classified as E-type are to be used only in suitably rated enclosed luminaires.

O = Lamps classified as O-type, comply with ANSI Standard C78.389 for containment testing and may be used in open luminaires.

S = When operated within 15 degrees of vertical, this lamp may be operated in an open luminaire provided the installation is not near people or flammable or combustible material, otherwise it must be operated in a suitably enclosed luminaire.

F = F-rated lamps require an enclosed fixture with a UV filter and lens interlock.

The 2005 NEC requires that luminaires which use a metal halide lamp shall be provided with either a containment barrier that encloses the lamp (historically referred to as an enclosed luminaire) or shall be provided with a means, typically a special lampholder, that will only accept an ANSI Type-O metal halide lamp. (Exception: This requirement will not apply to open luminaires with thick-glass parabolic reflector PAR lamps.)

UNDERSTANDING HIGH INTENSITY DISCHARGE LIGHTING (CONTINUED)

FIXTURE REQUIREMENT (continued)

The 2005 NEC also requires that metal halide luminaires for new construction/major renovations in the playing and spectator areas of indoor sports, mixed use, and all purpose facilities, which are subject to physical damage, must be of a type that protects the lamp with a glass or plastic lens. Open luminaires will not be permitted.

For more information regarding the use of Type-O, S and E metal halide systems, please refer to the NEMA white paper on this subject that is freely available at NEMA.org.

HOT RESTRIKE

In most instances, if an HID lamp experiences a momentary power interruption or sudden voltage drop, the lamp may extinguish. A lamp that is still hot will not restart immediately. Because the arc tube within the lamp must cool down before it can re-start, HID lamps have hot restrike times ranging from 1-15 minutes depending on the product type.

KEY TO DATE OF MANUFACTURE

Consult your SYLVANIA Sales Representative or call 1-800-LIGHTBULB.

LAMP WARNINGS

HID Metal Halide and Mercury lamps are marked with an "R" on their packaging. These letters provide safety information about the lamp. Below is the text used by the FDA to describe each of the letters.

R: WARNING: This lamp can cause serious skin burn and eye inflammation from shortwave ultraviolet radiation if outer envelope of the lamp is broken or punctured. Do not use where people will remain for more than a few minutes unless adequate shielding or other safety precautions are used. Lamps that will automatically extinguish when the outer envelope is broken or punctured are commercially available.

LIGHT CENTER LENGTH (LCL)

The light center length of HID lamps is a measurement from the center of the arc tube to the bottom of the lamp base.

LUMENS

Initial lumen ratings are based on photometry under controlled conditions of at least 10 hours per start in the prescribed position at rated lamp wattage after

100 operating hours. SOX lamp ratings are based on measurements at constant input voltage. Lamp performance under typical service conditions may vary from rated values. Operating universal METALARC® lamps in off-vertical positions will result in reduced lumen output.

Mean lumens are measured on ANSI reference circuits at rated wattage (SOX lamp ratings are based on input voltage) at 40% of average rated life except for those lamps with a "+" next to their life rating; these lamps are measured at 50% of average rated life. All measurements are based on ballast operation on systems with current crest factors of 1.8 or less. Higher current crest factors reduce values. In actual applications on CW or CWA ballasts, mean lumens may be higher than published ratings.

Unless otherwise noted, all photometry measurements are made on an ANSI reference ballast at rated lamp wattage.

MAXIMUM OVERALL LENGTH (MOL)

The maximum overall length of single-ended lamps is the maximum distance from the top of the bulb to the bottom of the base. For double-ended lamps, it is the maximum distance from end-to-end (excluding any leadwires).

ORDERING ABBREVIATION

Ordering abbreviation provides a shorthand description of the lamp, using a unique code, which can be used when ordering a lamp if you do not know the product number. This information can be found on the lamp etc.

PACKAGE QUANTITY

This identifies the number of lamps contained in a standard shipping carton.

PRODUCT NUMBER

The product number is a five-digit number used to identify a specific SYLVANIA lamp and should be used when ordering.

WARM UP TIME

Most HID lamps do not have instant on capabilities. It may take several minutes for the arc tube to stabilize before optimal light output is achieved.

WATTS

Watts shown are nominal lamp watts only.

HOW TO READ PRODUCT INFORMATION – HID

Watts	Bulb	Base	Product Number	Ordering Abbreviation	ANSI Ballast Code	Pkg Qty	Lamp Finish	Operating Position	Fix Req	Avg Rated Life (hrs)	Approx. Lumens (Initial)	(Mean)	CRI	CCT (K)
100	E17	E26 Med	67506	LU100/MED	S54	20	Clear	Universal	O	24000+	9500	8000	22	2100
320	BT37	E39 Excl Mogul	64851	MCP320/C/PS/BU-ONLY/840/BT37 PB	M154/O	6	Coated	Base up within 15° only	O	20000	36000	27000	88	3900
360	BT37	E39 Mogul	64655	MS360/SS/BU-HOR	M59/S	6	Clear	BU-HOR	S	20000V 15000H	36000V 30000H	23500V 19000H	65	4000
1000	BT37	E39 Mogul	64351	M1000/PS/U/BT37	M141/E	6	Clear	Universal	E	15000V 9000H	110000V 107800H	96000V 86300H	65	3800

Please refer to the "Understanding High Intensity Discharge" section on this and previous page for definitions and explanations of the category headers.

HOW TO READ ORDERING ABBREVIATIONS

MS360/SS/BU-HOR		MCP320/C/PS/BU-ONLY/840/BT37 PB		LU100/D/MED		H39KC-175/DX	
MS	SUPER METALARC®	MCP	METALARC® Ceramic PRO-TECH®	LU	LUMALUX®	H39	ANSI Ballast Number
360	Wattage	320	Wattage	100	Wattage	175	Wattage
SS	SUPERSAVER®	C	Coated	D	Coated	DX	Brite White Deluxe Coated
BU-HOR	Operating Position: Base up through Horizontal	PS	Pulse Start	MED	Medium Base		
		BU-ONLY	Operating Position: Base up only				
		840	80+ CRI; 4000 CCT				
		BT37	Bulb Type				
		PB	POWERBALL				

Specifications subject to change without notice.

HID BRAND NAME GUIDE

Note: These tables are intended only as guides and may represent another lamp company's most similar product or product family rather than an identical match. Individual manufacturer's performance values should be consulted.

HID BRAND NAMES

SYLVANIA	GE*	PHILIPS**
METALARC®	Multi-Vapor	Metal Halide
METALARC POWERBALL®	ConstantColor CMH	MasterColor
METALARC PRO-TECH®	Protected High Output Multi-Vapor	Protected Metal Halide
SUPER METALARC	High Output Multi-Vapor	Metal Halide
METALARC Pulse Start	PulseArc Multi-Vapor	Pulse Start Metal Halide
METALARC SUPERSAVER®	Watt-Miser Multi-Vapor	Metal Halide
METALARC BRITELINE®	Arcstream MQI	Double-Ended Metal Halide

*Trademark or registered trademark of General Electric Company

SYLVANIA	GE*	PHILIPS**
LUMALUX®	Lucalox	Ceramalux
LUMALUX / ECO®	Ecolux	Ceramalux ALTO
LUMALUX PLUS®/ ECO	Ecolux NC	Ceramalux ALTO NC
LUMALUX Standby	Standby Longlife Lucalox	Ceramalux Instant Restrike
SOX Low Pressure Sodium	SOX Low Pressure Sodium	SOX Low Pressure Sodium

**Trademark or registered trademark of Philips

PHYSICAL DIMENSIONS

BRITELINE®	PHYSICAL SIZE (dimensions in mm)	
Bulb	LCL	MOL
T7	127	256
T8	127	254
T9	127	254

MERCURY VAPOR (dimensions in inches)		
Bulb	LCL	MOL
E17	3.75	5.44
ET23.5	5	7.5
ED28	5	8.31
ED37	7	11.5
BT56	9.5	15.38
PAR38	—	5.44

METALARC® METAL HALIDE (dimensions in inches)		
Physical size of all Metalarc lamps		
Bulb	LCL	MOL
T4/TF	1.18	2.24
T4.5/TC	2	3.19
T6	2.2	3.94
T6 (DE)	2.25	4.5
T7.5	2.2	4.13
PAR20	—	3.65
PAR30LN	—	4.76
PAR38	—	5.32
E17/ED17	3.4	5.44
ET18 (250W)	5.75	9.75
ET18 (400W)	6.14	9.75
ET23.5	4.49	6.97
BT28/ED28	5	8.31
BT37	7	11.5
BT56	9.5	15.38

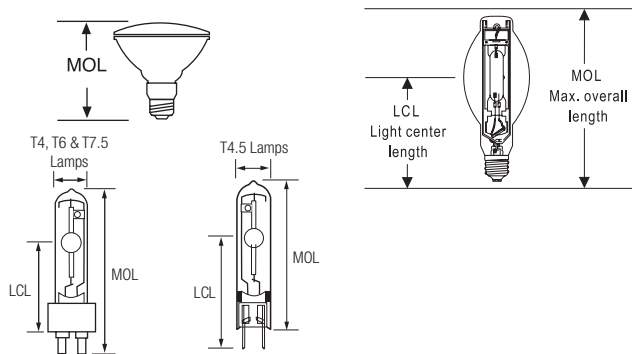

LUMALUX® HIGH PRESSURE SODIUM (dimensions in inches)		
Physical size of all LUMALUX lamps		
Bulb	LCL	MOL
T7	5	10.06
T14.5	6.89	11.22
E17	3.43	5.43
ET18	5.75	9.75
ET23.5	5	7.75
E25	8.75	15.08
BT28	5	8.98
BT37	7	11.5

BULBS

A bulb designation consists of a letter(s) to indicate the shape and a number(s) to indicate the approximate maximum diameter in eighths of an inch. Thus, an E17 lamp is an Ellipsoidal shape and 1-7/8 of an inch or 2-1/8 inches in diameter. Other letter designations include: BT = Bulbous Tubular; E or ED = Ellipsoidal; ET = Ellipsoidal Tubular; PAR = Parabolic; R = Reflector; T = Tubular.

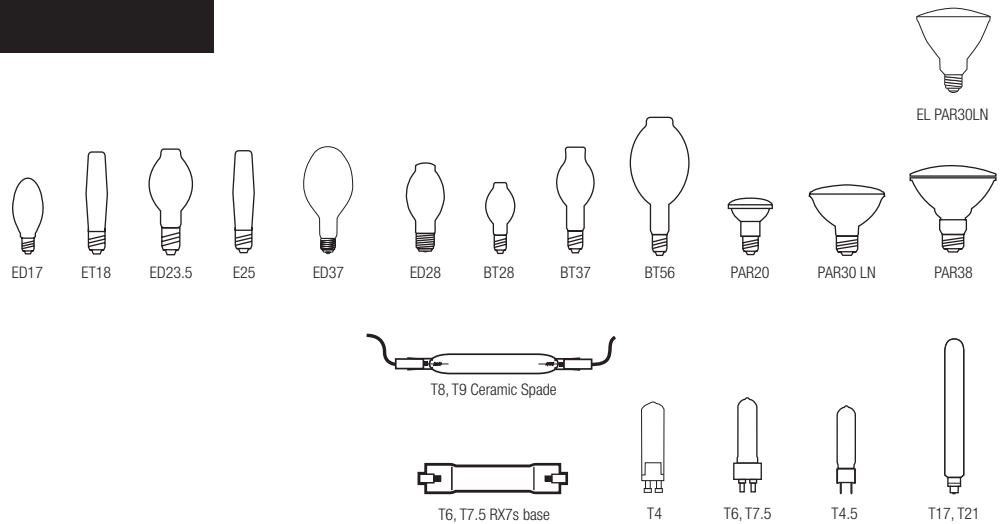

BASES

Lamps with screw bases have one lead-in wire soldered or welded to the center contact and the other soldered or welded to the upper rim of the base shell.

Bases with ceramic bodies have internal leads welded to either silver-plated contacts or external lead wires.

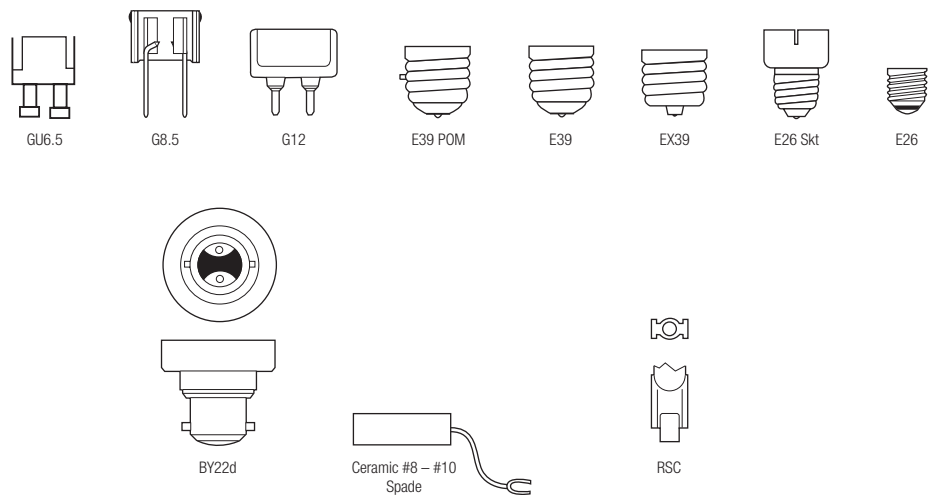

OPERATING POSITIONS

A designated operating position assures maximum lamp performance. Where it is not specified, the lamp is suitable for operation in any position.

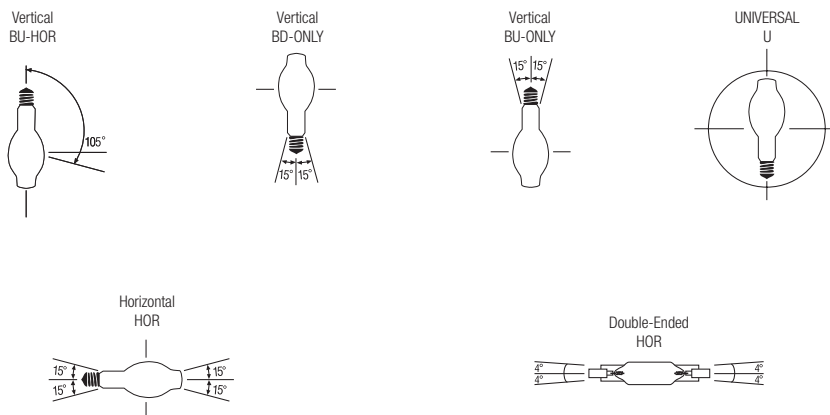

GUIDE TO METAL HALIDE LAMPS

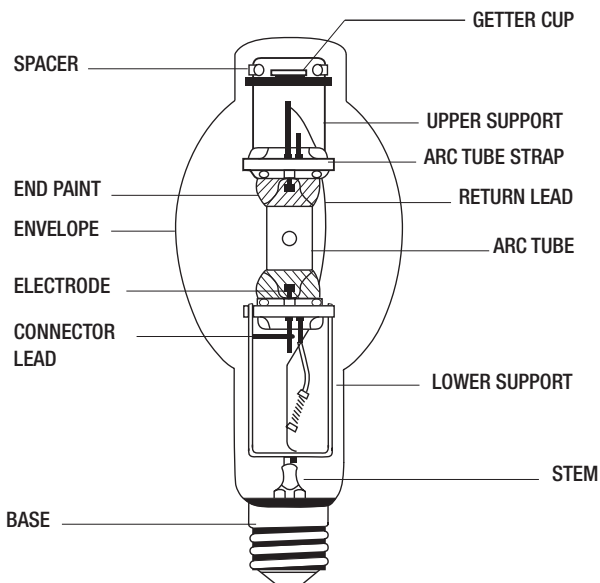

METALARC® Metal Halide lamps are designed for general lighting applications such as retail, commercial, industrial lighting and outdoor floodlighting where good color, long product life and high efficiency are desired. OSRAM SYLVANIA currently offers nine families of Metal Halide lamps:

STANDARD METALARC (M) – Offered in a range of wattages (from 175-1500 watts), standard METALARC metal halide lamps allow for design flexibility with multiple light source solutions to choose from. METALARC lamps have significantly higher efficacy than mercury vapor or incandescent products and considerably better CRI than mercury vapor and high pressure sodium lamps.

COMPACT METALARC (M/BT##) – These lamps have reduced outer jacket sizes compared to standard metal halide lamps for use in smaller fixtures. The reduced bulb diameter allows fixture manufacturers to design more versatile, less expensive and highly efficient luminaires.

SUPER METALARC (MS) – Super METALARC lamps are position dedicated, which means that they are specifically designed to be run in particular operating positions. Because of this feature, these lamps exhibit improved performance over standard, universal operating metal halide lamps of similar wattage. Product features include long life, higher maintained lumens and increased efficacy.

METALARC® PRO-TECH® (MP) – These are specially designed lamps that incorporate a protective shroud to contain a non-passive arc tube failure. METALARC PRO-TECH lamps can be used in open or enclosed fixtures. Dedicated bases are standard on both low and high wattage lamp types.

METALARC POWERBALL® CERAMIC (MC or MCP) – POWERBALL lamps use a patented round ceramic arc tube, which allows for a more uniform arc tube temperature, higher color rendering (>85) and improved color consistency. These lamps are ideal for applications that demand the best in color performance.

METALARC POWERBALL® EL (MCP) – The self-ballasted POWERBALL EL lamps offer energy saving solutions for applications desired superior light quality and are ideal replacements for halogen or incandescent lamps.

METALARC PULSE START (M/PS) – METALARC Pulse Start lamps utilize metal halide performance with proven ignitor technology for longer life, improved lumen maintenance and reduced color shift over lamp life compared to standard metal halide products. Lamp configurations include low and high wattage types, both clear and coated. METALARC PRO-TECH designs are also available for open fixture applications. All METALARC products lower than 175W and all METALARC POWERBALL products utilize Pulse Start technology exclusively.

METALARC SUPERSAVER® (M/SS) – Constructed with an enhanced arc tube for peak performance, METALARC SUPERSAVER lamps are designed as energy-saving, replacement metal halide lamps. The 360W SUPERSAVER lamp is a direct retrofit for existing 400W products, the 950W SUPERSAVER replaces 1000W lamps and the 150W SUPERSAVER replaces 175W lamps – no ballast change is required.

METALARC BRITELINE® (M) – These double-ended lamps are designed for compact fixtures, which provide excellent optical control and high efficiency. These higher wattage lamps are particularly well suited for sports lighting and outdoor floodlighting applications.

GUIDE TO HIGH PRESSURE SODIUM LAMPS

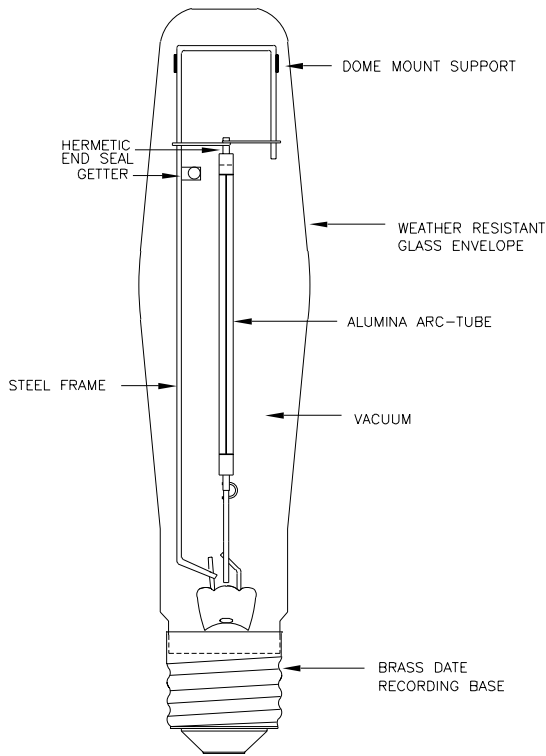

High Pressure Sodium lamps are one of the most efficient HID sources available today. These lamps are used for general lighting applications where high efficiency and long life are desired while color rendering is not critical. Typical applications include street lighting, parking lot lighting, building floodlighting and general area lighting.

LUMALUX PLUS® / ECO® AND LUMALUX PLUS – These environmentally friendlier lamps contain significantly less Mercury than standard high pressure sodium lamps. They will not cycle at the end of life and are rated for 40,000 hours life. All lamps operate on existing high pressure sodium ballasts. LUMALUX Plus / ECO lamps are designed with lead-free bases and they pass the existing Federal TCLP limits.*

LUMALUX® AND LUMALUX / ECO – Available in a broad range of wattages, in both clear and coated configurations, LUMALUX and LUMALUX / ECO lamps are ideal for a variety of applications. LUMALUX medium based lamps are available in wattages ranging from 35-150 watts while mogul based lamps are offered in 50-1000 watts. The mogul based LUMALUX / ECO lamps operate on standard high pressure sodium ballasts and pass the Federal TCLP text.*

LUMALUX STANDBY – These lamps are designed with two arc tubes to provide instant restrike capability in the event of a momentary power interruption. With almost twice the life of standard high pressure sodium lamps, LUMALUX Standby lamps are a great way to reduce maintenance costs.

SOX – These energy efficient low pressure sodium lamps emit a characteristic yellow light that is ideal for certain exterior street and area lighting.

*based on NEMA LL Series Standards

GUIDE TO HIGH MERCURY VAPOR LAMPS

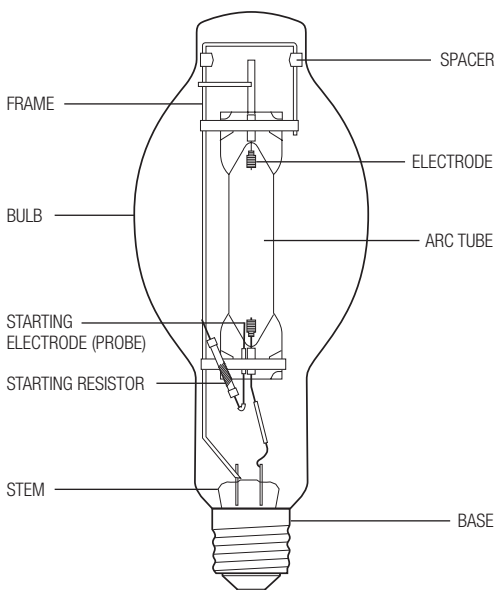

OSRAM SYLVANIA Mercury lamps are designed primarily for use in general lighting applications where good efficiency and long life are desired while color rendering requirements are moderate. Applications include street lighting, industrial hi-bay, parking lot lighting and general flood lighting.

STANDARD MERCURY – Available in a wide range of lamp types from 75-1000 watts, in both clear and coated configurations, Mercury vapor lamps are ideal for a variety of lighting applications. PAR lamps offer floodlighting and ultra-violet spectra for special lighting applications.



E17



ED28



ET23.5



ED37, ED28



BT37

METALARC® Pulse Start Lamps

High Output, Reduced Color Shift Metal Halide Lamps for Enclosed Fixtures

See product information bulletins (HID021 and HID059) for product details

Watts	Bulb	Base	Product Number	Ordering Abbreviation	ANSI Code/ Fixture Req.	Pkg Qty	Lamp Finish	Operating Position	Average Rated Life (hrs)	Initial Lumens (Mean)	CRI	CCT (K)	Lamp Efficacy (LPW)
70	E17	E26Med	64836	M70/U/MED	M98/E	12	Clear	Universal	12000	5600 (3400)	75	4000	80
100	E17	E26Med	64818	M100/U/MED	M90/E	20	Clear	Universal	12000	8500 (4675)	75	4000	85
150	E17	E26Med	64785	M150/U/MED	M102/E	20	Clear	Universal	12000	12900 (4300)	75	4300	86
175	E17	E26Med	64171	MS175/PS/BU-ONLY/MED	M152/E	12	Clear	BU ±15°	15000	17500 (12800)	65	4000	100
175	ED28	E39 Mogul	64043	M175/PS/U/ED28	M152/E	6	Clear	Universal	12000V 9000H	14400V (10000V) 12800H (8300H)	65	4000	82V 73H
			64815	MS175/PS/BU-ONLY	M152/E	12	Clear	BU ±15°	15000	17500 (12800)	65	4000	100
			64816	MS175/C/PS/BU-ONLY	M152/E	12	Coated	BU ±15°	15000	16600 (12500)	70	3700	95
200	ET23.5	E39 Mogul	64837	MS200/PS/BU-ONLY/ET23.5	M136/E	12	Clear	BU ±15°	15000	19000 (13300)	65	4200	95
200	ED28	E39 Mogul	64044	MS200/PS/BU-ONLY/ED28	M136/E	6	Clear	BU ±15°	15000	19000 (13500)	65	4000	95
			64045	MS200/C/PS/BU-ONLY/ED28	M136/E	6	Coated	BU ±15°	15000	18000 (12800)	70	3800	90
250	ED28	E39 Mogul	64046	M250/PS/U/ED28	M153/E	6	Clear	Universal	15000V 12000H	21000V (18000H) 15400V (11000H)	65	3800	88V 76H
			64047	MS250/PS/BU-ONLY/ED28	M153/E	6	Clear	BU ±15°	20000 ¹	23000 (17000)	65	4200	92
			64048	MS250/C/PS/BU-ONLY/ED28	M153/E	6	Clear	BU ±15°	20000 ¹	21500 (15500)	70	3600	86
320	ED28	E39 Mogul	64049	MS320/PS/BU-HOR/ED28	M154/E	6	Clear	Universal	20000V 15000H	30000V (21000V) 28000H (19700H)	65	4300	94 88
			64050	MS320/C/PS/BU-HOR/ED28	M154/E	6	Coated	Universal	20000V 15000H	30000V (19700V) 28000H (18400H)	70	3900	94 88
400	ED28	E39 Mogul	64051	M400/PS/U/ED28	M155/E	6	Clear	Universal	20000V 15000H	36000V (25500V) 31000H (22400H)	65	4000	90 78
			64052	MS400/PS/BU-ONLY/ED28	M155/E	6	Clear	BU ± 15	20000	40000 (32500)	65	4100	100
			64053	MS400/PS/BU-ONLY/ED28	M155/E	6	Clear	BU ± 15	20000	40000 (32500)	65	4100	100
400	ED37	E39 Mogul	64054	M400/PS/U/ED28	M155/E	6	Clear	Universal	20000V 15000H	36000V (25500V) 31000H (22400H)	65	4000	90V 78H
			64055	MS400/PS/BU-ONLY/ED37	M155/S	6	Clear	Universal	30000 20000	42000V (29000V) 42000H (35700H)	65	4000	105 105
			64056	MS400/C/PS/BU-ONLY/ED37	M155/S	6	Coated	Universal	30000 20000	42000V (29000V) 42000H (35700H)	70	3600	105 105
750	BT37	E39 Mogul	64787	MS750/PS/BU-HOR/BT37	M149/E	6	Clear	BU-HOR	20000V 9000H	78000V (67000V) 68000H (56000H)	65	4000	104 91
			64822	MS750/C/PS/BU-HOR/BT37	M149/E	6	Coated	BU-HOR	20000V 9000H	75000V (63000V) 65000H (53000H)	70	3700	100 87
1000	BT37	E39 Mogul	64351	M1000/PS/U/BT37	M141/E	6	Clear	Universal	20000V 9000H	110000V (96000V) 107800H (86300H)	65	3800	110 108

Lamps between 175W and 400W operating on ballasts having a sustaining voltage less than 270V, lamp life may be significantly reduced.

Lamps > 400W operating on ballasts having a sustaining voltage less than 310V, lamp life may be significantly reduced.

¹ 20,000 average rated life based on 10 hrs/start. 30,000 average rated life based on 120 hrs/start.