

IMPORTANT INSTRUCTIONS AND OPERATING MANUAL

ELECTRIC FIREPLACE

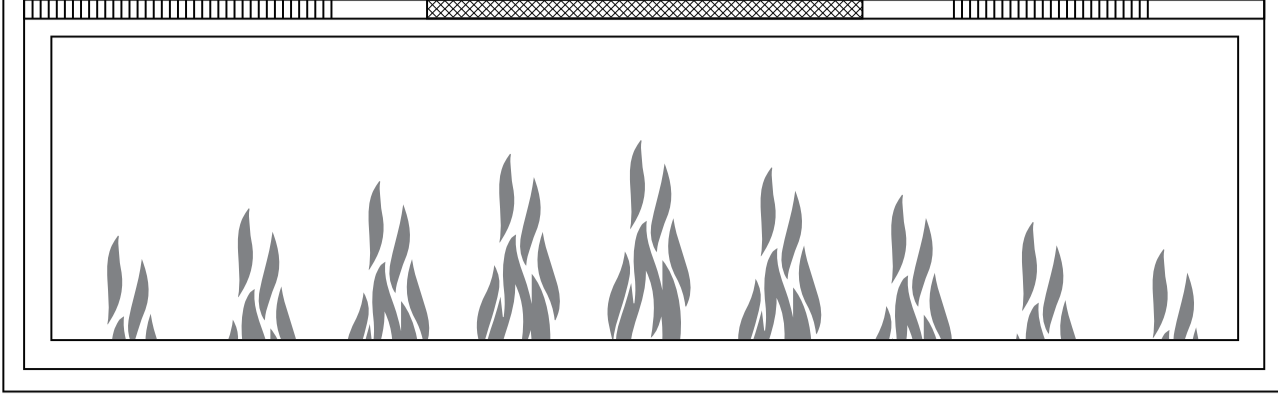

**JBK36E-DBL-SSDQ/JBK42E-DBL-SSDQ
JBK50E-DBL-SSDQ/JBK60E-DBL-SSDQ
JBK66E-DBL-SSDQ/JBK72E-DBL-SSDQ**

NO VENTING REQUIRED

WARNING
Read and understand this entire owner's manual, including all safety information before plugging in or using the appliance. Failure to do so could result in fire, electric shock or serious personal injury.

wolflontech@gmail.com
Please choose SMS or email as your first choice for communicating with us.

CERTIFIED UNDER CANADIAN AND AMERICAN NATIONAL STANDARDS ITC
INFORMATION 6024127

TABLE OF CONTENTS

IMPORTANT SAFETY INSTRUCTIONS 4
 1. PACKING LIST 6
 1.1 DIMENSIONS 6
 2. ELECTRICAL INSTALLATION NOTES 10
 3. INSTALLATION INSTRUCTIONS 11
 3.1 UNPACKING AND TESTING APPLIANCE WALL 11
 3.2 DRILLING AND INSTALLING MOUNTING BRACKET 11
 3.3 DRILLING 12
 3.4 DRILLING 12
 3.5 DRILLING 12
 3.6 DRILLING 12
 4. FINISHING 17
 5. OPERATING INSTRUCTIONS 20
 5.1 REMOTE CONTROL 20
 5.2 CONTROLL PANEL/REMOTE CONTROL OPERATION 20
 6. TROUBLE SHOOTING GUIDE 23
 7. MAINTENANCE 25
 7.1 PARTIALLY REFLECTIVE GLASS CLEANING 25
 7.2 CLEANING CAUTION 26
 8. RETURN WARRANTY 26
 9. O&A CONTACT INFORMATION 27

IMPORTANT SAFETY INSTRUCTION

WARNING

These instructions should be carefully read before installation. The booklet must be kept and delivered to the new user. The Manufacturer reserves the right to vary the features of the product without prior notice. The technical data are indicative only.

1. THIS APPLIANCE IS HOT WHEN OPERATED AND CAN CAUSE SEVERE BURNS IF TOUCHED.
2. Do not operate appliance before reading and understanding instructions. Failure to operate appliance could cause fire or injury.
3. Keep this product away from combustible materials at least 3 feet (93 mm), such as furniture, pillows, bedding, papers, clothes and curtains at least 3 feet (93 mm). WARNING: In order to avoid overheating, do not cover the heater. The space may be inadequate when installed in a recreational vehicle.
4. Risk of burns. Please do not touch the appliance directly after use and cooling for a while. Please turn off the control and then remove plug if you want disconnect power of appliance.
5. Do not install damaged or frangible components.
6. Young children should be carefully supervised when they are in the same room with the appliance. They may be susceptible to accidental contact with the appliance.
7. Do not install damaged, incomplete or substitute components.
8. There is small batteries in the remote. Please keep away from children.
9. To prevent accidental suffocation, small parts should be kept away from children and infants.
10. Do not install battery in the wrong direction, put it close fire or mix with other type of batteries.
11. Ensure you have adequate safety measures to protect infants/toddlers from touching hot surfaces.
12. It is imperative that the control components, circulating blower and ventilation observed in the appliance are kept clean. The appliance should be inspected before use and serviced by a qualified service person every year.
13. Under no circumstances should this appliance be modified.
14. Do not use this appliance if any part has been in contact with water. Please call a qualified service technician to inspect the appliance immediately and to replace the parts which has been in contact with water.
15. Do not operate the appliance when the glass door is removed, cracked or broken. Replacement of the glass panel should be done by a qualified service person.
16. Do not strike the glass door of appliance.
17. Keep the packaging material away from children and dispose of the materials in a safe manner.

1

18. Always unplug appliance when not in use.

19. Do not operate the appliance with a damaged cord or plug after the appliance malfunctions, please return appliance to authorized service facility for electrical or mechanical adjustment, or repair.

20. Do not use appliance outdoors.

21. Never place appliance where it may fall into a bathtub or other water container.

22. Do not run cord under carpet. Do not cover cord with throw rugs, furniture etc. Place cord away from cluttered areas and where it will not be tripped over.

23. Connect to properly grounded outlet only.

24. Do not insert or allow foreign objects to enter any ventilation or exhaust valve as this may cause an electric shock or fire, or damage the appliance.

25. To prevent fire cases, do not block the air intake or exhaust valve in any way. Do not use appliance on soft surfaces, such as carpet, where exhaust valve may become blocked.

26. Always plug appliance directly into a wall outlet/strip socket. Do not use extension cord or relocate power to another power strip.

1.0 PACKING LIST

| NO. | Description | Quantity |
|-----|-------------------------|--|
| 1 | Front Frame | 1 pc |
| 2 | Electric Fireplace | 1 pc |
| 3 | Back hook(Pin-attached) | 36E-42E-50E (2PCS) 60E-66E-72E (2PCS) |
| 4 | Manual | 1 pc |
| 5 | Decorative Staff | Varies |
| 6 | Remote Control | 1 pc |
| 7 | Bumper bracket | 36E-42E-50E (2PCS) 60E-66E-72E (2PCS) |

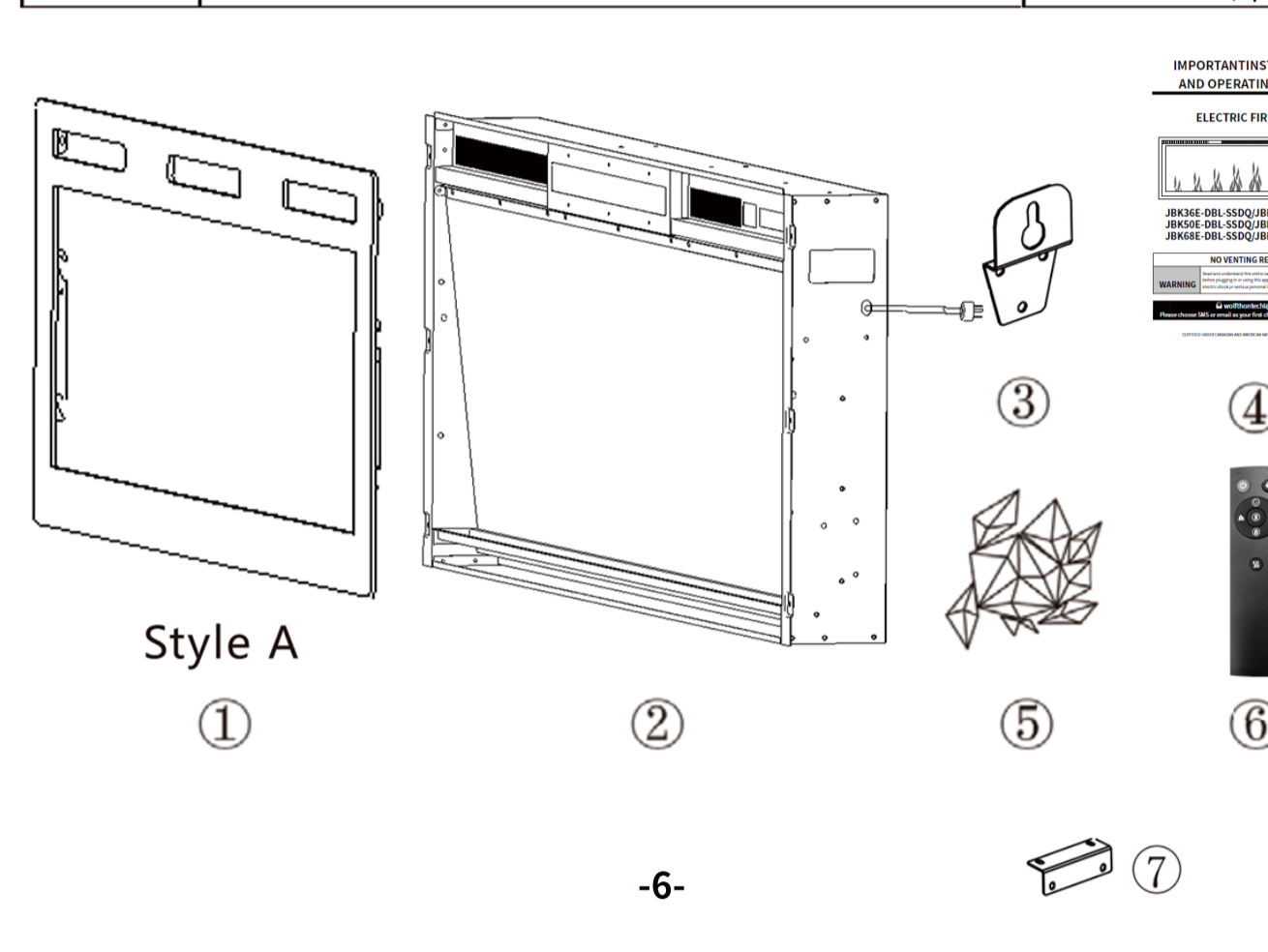

Style A

2

HARDWARE INCLUDED

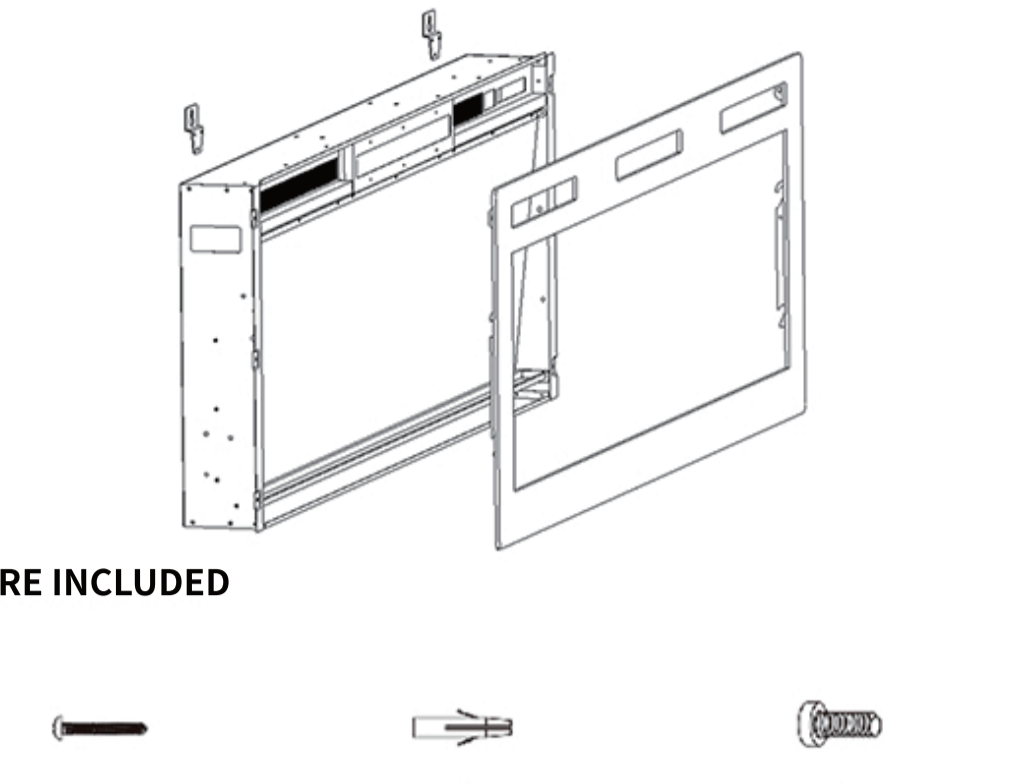

| Part | Description | Model | Number |
|------|-----------------------------------|-------------|--------|
| A | ST5*30mm | 36E-42E-50E | 6pcs |
| | | 60E-66E-72E | 8pcs |
| B | M8*35mm Plastic expansion tube | 36E-42E-50E | 6pcs |
| | | 60E-66E-72E | 8pcs |
| C | ST4*12mm Glass fixing screws | 36E-42E-50E | 2pcs |
| | | 60E-66E-72E | 10pcs |
| | | 60E-66E-72E | 16pcs |

The hook has a safety bracket mounting screw

3

1.1 DIMENSIONS

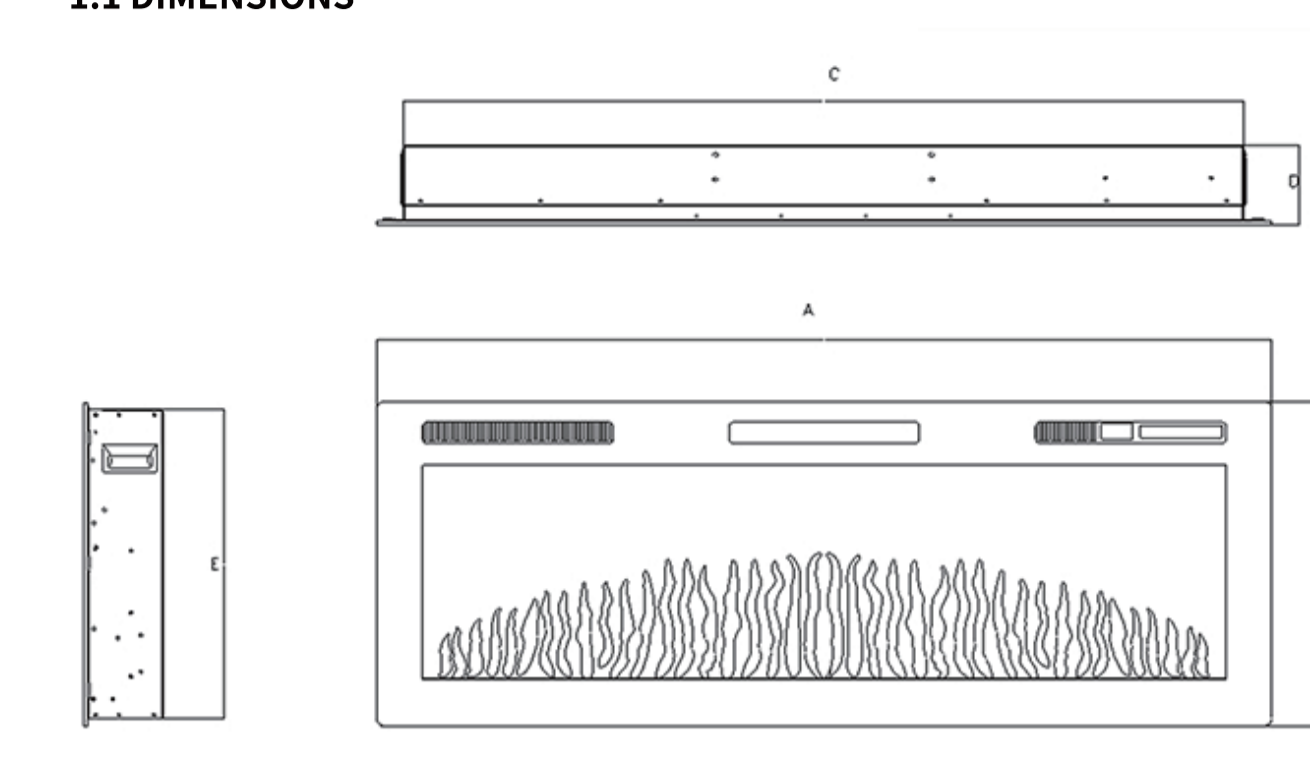

| Model | Ann | B(mm) | C(mm) | D(mm) | Emm | Ann | Bin | Cin | Din | Ein |
|--------|------|-------|-------|-------|-----|-----|-------|-------|------|-------|
| JBK36E | 914 | 460 | 836 | 113 | 440 | 36 | 18.11 | 32.91 | 4.33 | 17.32 |
| JBK42E | 1067 | 460 | 988 | 113 | 440 | 36 | 18.11 | 38.9 | 4.33 | 17.32 |
| JBK50E | 1270 | 460 | 1191 | 113 | 440 | 50 | 18.11 | 46.89 | 4.33 | 17.32 |
| JBK60E | 1524 | 460 | 1495 | 113 | 440 | 60 | 18.11 | 56.89 | 4.33 | 17.32 |
| JBK66E | 1728 | 460 | 1648 | 113 | 440 | 68 | 18.11 | 64.88 | 4.33 | 17.32 |
| JBK72E | 1828 | 460 | 1750 | 113 | 440 | 72 | 18.11 | 68.9 | 4.33 | 17.32 |

4

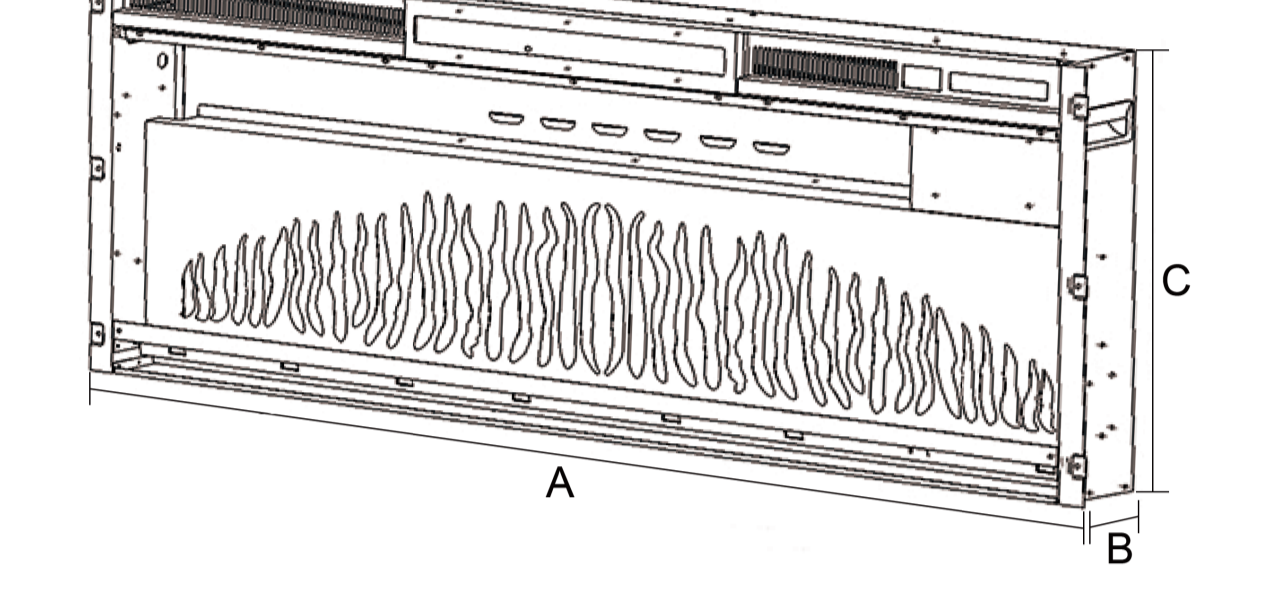

| Model | A(mm) | B(mm) | C(mm) | A (in) | B (in) | C (in) |
|--------|-----------|---------|---------|-------------|-----------|-------------|
| JBK36E | 846-856 | 115-125 | 445-450 | 33.1-33.7 | 4.53-4.92 | 17.52-17.72 |
| JBK42E | 998-1008 | 115-125 | 445-450 | 39.29-39.89 | 4.53-4.92 | 17.52-17.72 |
| JBK50E | 1201-1211 | 115-125 | 445-450 | 47.28-47.68 | 4.53-4.92 | 17.52-17.72 |
| JBK60E | 1455-1465 | 115-125 | 445-450 | 57.28-57.68 | 4.53-4.92 | 17.52-17.72 |
| JBK66E | 1658-1668 | 115-125 | 445-450 | 65.28-65.68 | 4.53-4.92 | 17.52-17.72 |
| JBK72E | 1760-1770 | 115-125 | 445-450 | 69.29-69.89 | 4.53-4.92 | 17.52-17.72 |

5

NOTE:
The size of column B left some space for the main power switch on the top, you can also choose 1.54 inch top embedding, since the booth cover also has a main power switch.

Please leave enough space to place the power cord on the right side of the fireplace.

LISTING APPROVALS

This appliance has qualified with the ETL. Standards for fixed and wall-mounted electric heat and electric space heaters in the United States and Canada. For more information during installation, please contact your local distributor.

APPROX: This appliance must be electrically earthed and grounded in accordance with local or, in the absence of local, national or international standards, in accordance with the Canadian Electrical Code, ETL in Canada.

| Model No. | UL Model No. | UL Listing No. |
|-------------|--------------|----------------|
| 36E-42E-50E | ETL-1200 | ETL-1200 |
| 60E-66E-72E | ETL-1200 | ETL-1200 |
| APPROX | ETL-1200 | ETL-1200 |
| ETL-1200 | ETL-1200 | ETL-1200 |

6

A FIRE RESULT MAY CAUSING PROPERTY DAMAGE, PERSONAL INJURY, OR DEATH IF THE CUSTOMER DOES NOT FOLLOW THE INSTRUCTION EXACTLY, DO NOT STORE OR USE GASOLINE OR OTHER FLAMMABLE LIQUIDS IN THE VICINITY OF THE APPLIANCE. THIS APPLIANCE IS HEAVY, THERE ARE TWO PEOPLE FOR INSTALLING. IN ANY HEAVY LIFTING OR THE ELECTRICAL APPLIANCE CAN NOT BE COVERED AS IT MAY LEAD TO A FIRE HAZARD.

THE FIRE HAZARD RESULT.

Follow all national and local electrical codes.

1. The heater should be installed only using the mounting brackets we provided.
2. The heater can not be recessed in the ceiling. There must be enough space around the top of the heater to ensure adequate ventilation.
3. The heater should be installed at least 3 feet away from surrounding walls.
4. At least 90 cm should always be left in front of the heater to ensure safety.
5. The heater can not be located either directly below, or in front of a socket outlet.
6. The heater must be installed to prevent any control switches from being able to be touched by anyone who is in the shower or bath.
7. Make sure that there is no possibility of flammable material, combustible material, or curtains coming into contact with the heater.
8. DO NOT USE THE HEATER WITHOUT SUPERVISION.

7

3.3 ASSEMBLY

The fireplace can be installed with 2 options:

1. Wall hanging, with provided mounting bracket.
2. Built-in construction (in wall recess).

Follow the installation instructions below based on installation preference.

Option 1:
Wall Hanging.....page 13-16

Option 2:
Built-in construction.....page 17-19

8

Installation Option 1-Wall Hanging

The fireplace can be installed with 2 options:

1. Remove the fixed screws on the glass plate.
2. Lift the glass frame 1.2 cm vertically. Then the entire glass frame can be removed from the front. Take the glass frame 10-20 cm away from the appliance, put the glass panel down on the ground before complete separation.

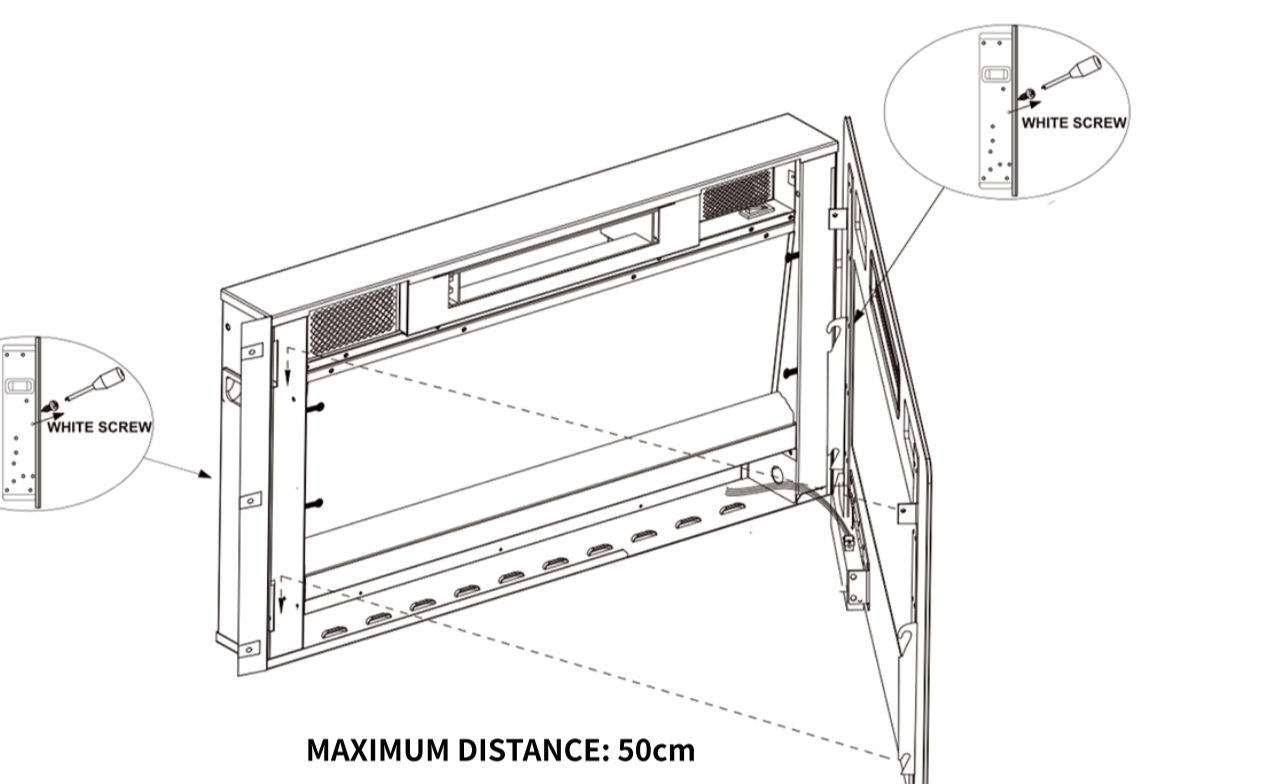

MAXIMUM DISTANCE: 50cm

JBK36E-DBL-SSDQ JBK42E-DBL-SSDQ JBK50E-DBL-SSDQ
JBK60E-DBL-SSDQ JBK66E-DBL-SSDQ JBK72E-DBL-SSDQ

9

2.0 ELECTRICAL INSTALLATION NOTES

2.1 GENERAL INSTRUCTIONS

CAUTION: Some parts of this product can become hot and it may cause burns. Pay attention to keep away from them.

A. Always confirm that house circuit breakers for the outlet are on, before plugging your appliance into an outlet.

B. The appliance may emit a slight harmless odor when first used. It is caused by the initial heating of internal appliance elements and will not occur again.

C. If your appliance does not emit heat, check the electrical connection section of this manual for further information.

D. Use with an ETL or UL certified protector.

WARNING: RISK OF FIRE: THE POWER CORD MUST NOT BE PINCHED AGAINST A SHARP EDGE. SECURE CORD TO AVOID TRIPPING OR DAMAGE TO REDUCE THE RISK OF FIRE. ELECTRICAL SHOCK AND PERSONAL INJURY. DO NOT RUB CORD UNDER CARPETING. DO NOT COVER THE CORD AROUND CLUTTERED AREAS AND WHERE IT WILL NOT BE TRIPPED OVER. ARRANGE THE CORD AWAY FROM CLUTTERED AREAS AND WHERE IT WILL NOT BE TRIPPED OVER. FIRE RISK: FIRE TO PREVENT A POSSIBLE FIRE, DO NOT BLOCK AIR INTAKE OR EXHAUST VALVE IN ANY MANNER. DO NOT USE IT ON SOFT SURFACES. FIRE OPENINGS MAY REDUCE BACKDRAFT RISK OF FIRE! DO NOT BLOW OR PLACE INSULATION AGAINST THE APPLIANCE. THIS ELECTRIC APPLIANCE IS TESTED AND LISTED FOR USE ONLY WITH THE APPROVED OPTIONAL ACCESSORIES. USE OTHER ACCESSORIES THAT NOT TESTED FOR THIS ELECTRIC APPLIANCE COULD DISABLE THE WARRANTY AND THE FIRE HAZARD RESULT.

10

3.0 INSTALLATION INSTRUCTIONS

3.1 UNPACKING AND TESTING APPLIANCE WALL

Carefully remove the appliance from the box. Before installing the appliance, make sure the appliance operates properly by plugging the power supply cord into a conveniently located 120V/60Hz grounded outlet.

3.2 GROUNDING APPLIANCE

This appliance is for use on 120 Volts. The cord has a plug as shown in (A) an adapter as shown in (C) is available for connecting three blade grounding plug to two-slot receptacles. The green grounding lug extending from the adapter must be connected to a permanent ground such as a properly grounded outlet box. The adapter should not be used if a three-slot grounded receptacle is available.

To disconnect the appliance, turn the controls off, then remove the plug from the outlet.

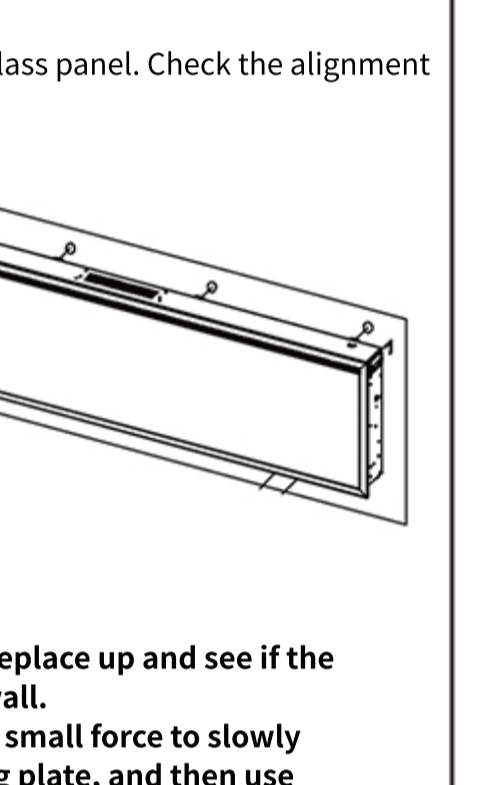

11

3.1 UNPACKING AND TESTING APPLIANCE WALL

Step 5. Hanging the Fireplace on the Bracket

Thread the ST4*12 screw into the threaded holes on the glass panel. Check the alignment. Gently push on the glass panel by aligning the 4 hooks until it snaps into position (sinks down 1.2 cm).

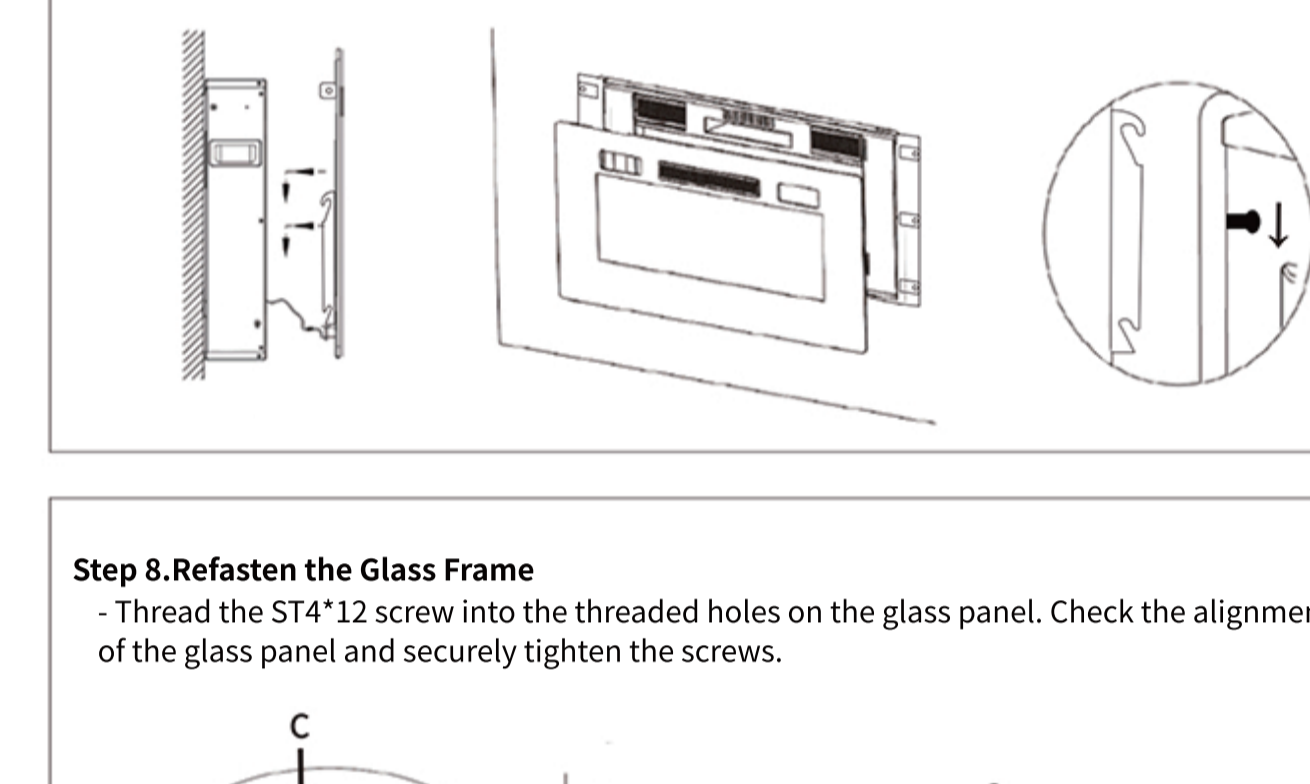

Step 6. Placing the Decorations

Place the decorative objects together with the appliance or other decoration into the bottom tray on the front of the appliance as illustrated.

NOTE: Media bed bits may have sharp edges, wear safety goggles and gloves when handling.

12

Installation - Built in Construction

Step 1. Removing the Glass Frame

Step 2. Attaching the Mounting Bracket

(Step 1 and Step 2 please refer to page 13-14 same as Wall Hanging installation.)

Step 3. Setting the Holes of Screw

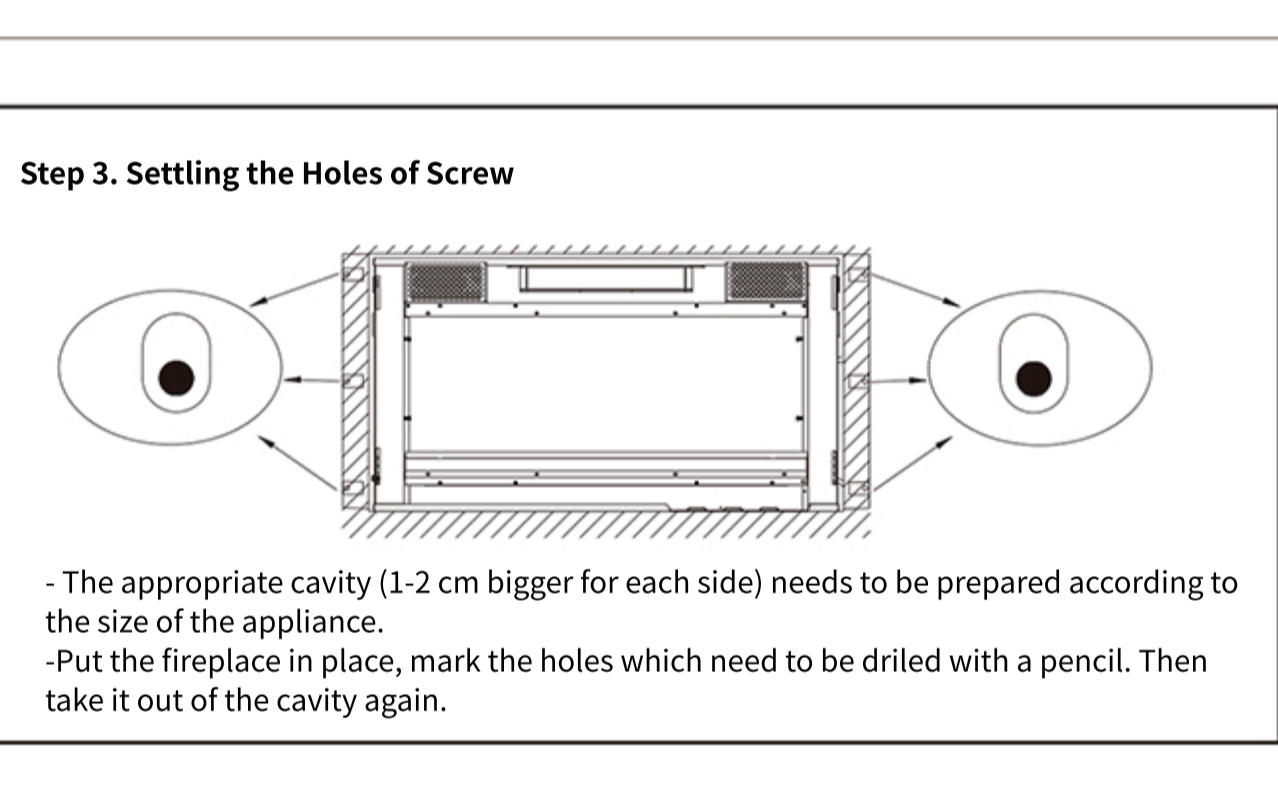

The appropriate cavity (2-3 inches deep) needs to be prepared according to the size of the appliance.

Place the fireplace in place. Mark the holes which need to be drilled with a pencil. Then take it out of the cavity again.

13

2.0 ELECTRICAL INSTALLATION NOTES

2.2 ELECTRICAL INSTALLATION NOTES

Step 4. Drilling & Installing the Wall Anchors

Drill the holes 7/16 in. (7 mm) on the prepared marks. Install the wall anchors (Part B) into the holes by using a hammer.

Step 5. Placing the Pads and Fixing the Fireplace

Screw (Part A) pass through the holes from the front of fireplace with screwdriver.

NOTE: Install carefully and don't let the screws fall into the fireplace.

Put the fireplace into the prepared cavity.

Fasten the fireplace firmly into the wall by the screws for each side.

14

3.0 INSTALLATION INSTRUCTIONS

3.2 GROUNDING APPLIANCE

Step 6. Placing the Decorations

Place the decorative objects together with the appliance or other decoration into the bottom tray on the front of the appliance as illustrated.

NOTE: Media bed bits may have sharp edges, wear safety goggles and gloves when handling.

Step 7. Hanging the Glass Frame

Connect the data cable connector before hanging the glass frame on the appliance. Gently push on the glass panel by aligning the 4 hooks until it snaps into position (sinks down 1.2 cm).

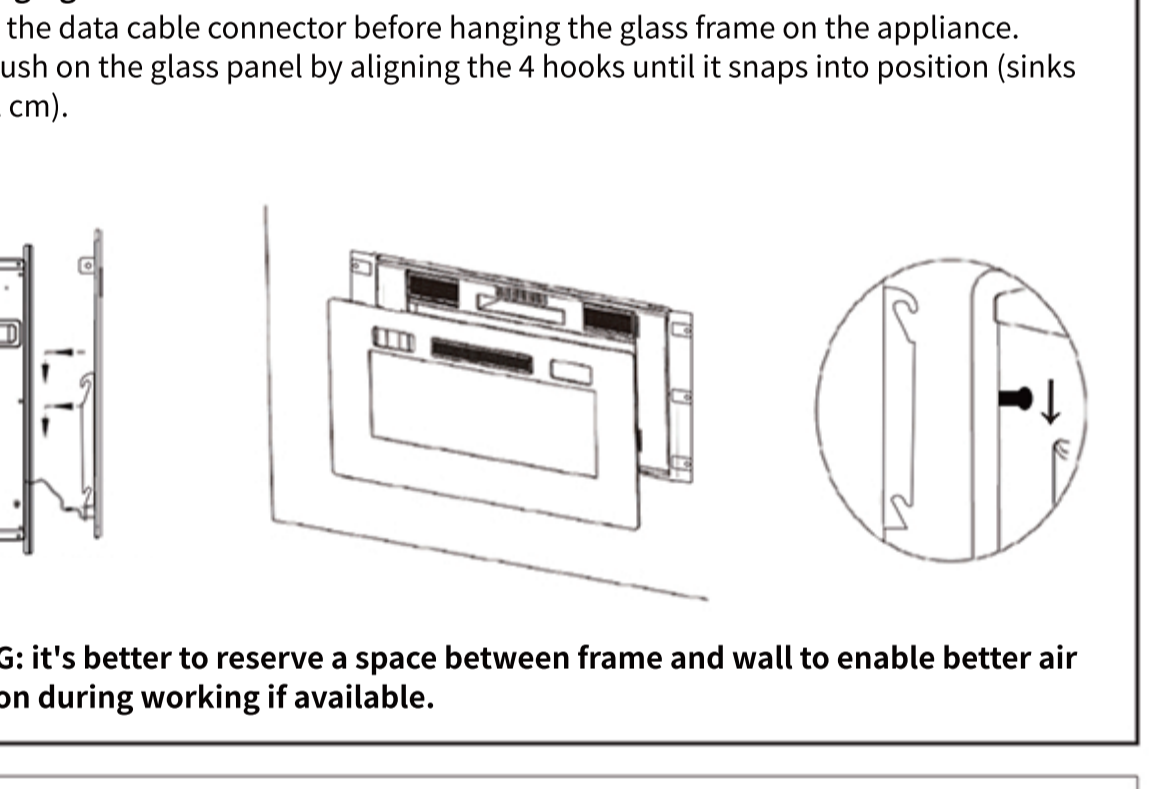

WARNING: It's better to reserve a space between frame and wall to enable better air circulation during working if available.

Step 8. Refasten the Glass Frame

Thread the ST4*12 screw into the threaded holes on the glass panel. Check the alignment of the glass panel and securely tighten the screws.

15

4.0 FINISHING

GRILLE MAY BE HOT. DO NOT TOUCH AIR OUTLET UNTIL COOLED. THE DOOR HOOKS ARE PART OF A SAFETY SYSTEM AND MUST BE PROPERLY ENGAGED. DO NOT OPERATE THE APPLIANCE WITH HOOKS ENGAGED. FINISHING MATERIALS MUST NOT INTERFERE WITH AIR FLOW THROUGH AIR OPENINGS. OBTAIN CLEAR ACCESS FOR SERVICE. COVER ALL CLEANING MATERIALS. COMBUSTIBLE MATERIALS. BEFORE DOOR IS REMOVED, TURN THE APPLIANCE OFF AND WAIT UNTIL APPLIANCE IS COOL. DOORS ARE HEAVY AND FRAGILE. DO HANDLE WITH CARE.

NOTE: Glass front must be removed and the appliance must be finished in its final location before the media bed bits are installed. Media bed bits may have sharp edges, wear safety goggles and gloves when handling.

16

5.0 OPERATING INSTRUCTION

5.1 MAIN POWER BUTTON

The main power switch for the fireplace is on the front right.

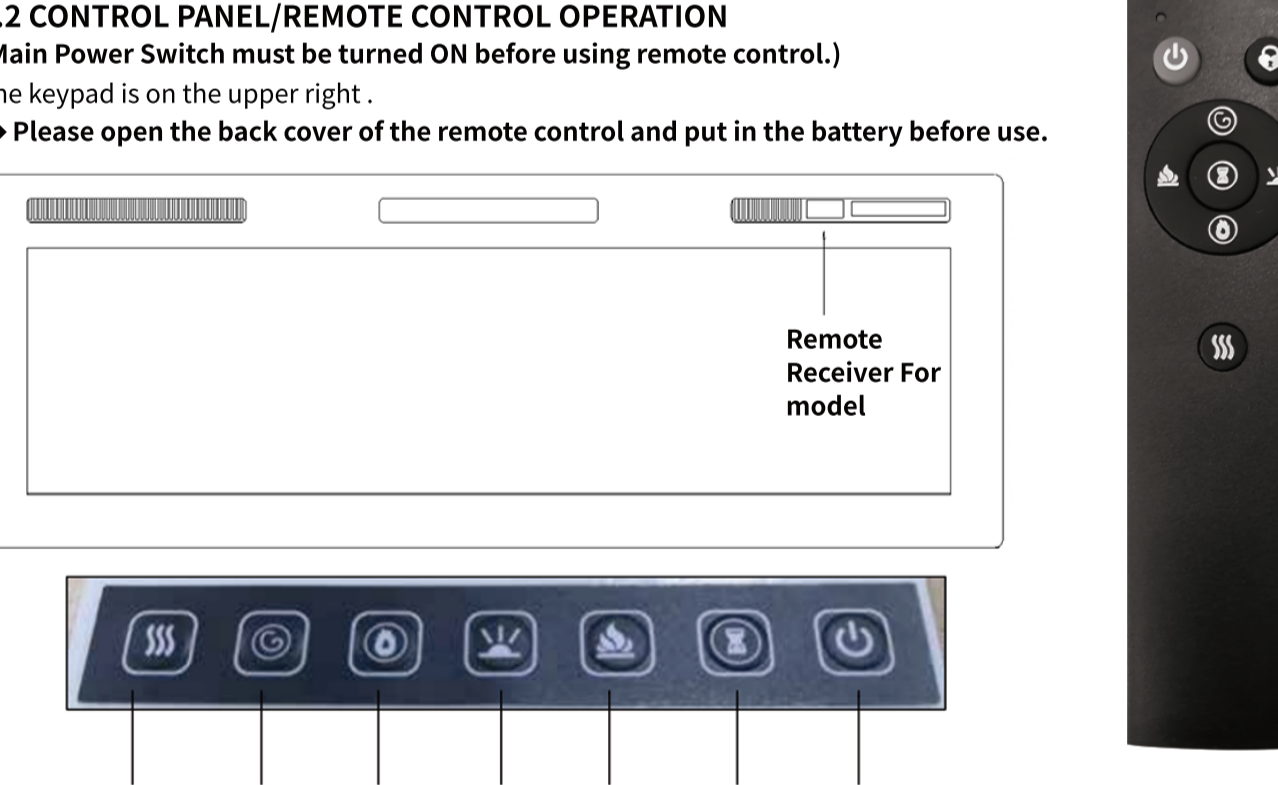

17

5.0 OPERATING INSTRUCTION

5.2 CONTROLL PANEL/REMOTE CONTROL OPERATION

Main Power Switch must be turned (before remote control).

PLEASE OPEN THE COVER OF THE REMOTE CONTROL AND PUT IN THE BATTERY BEFORE USE.

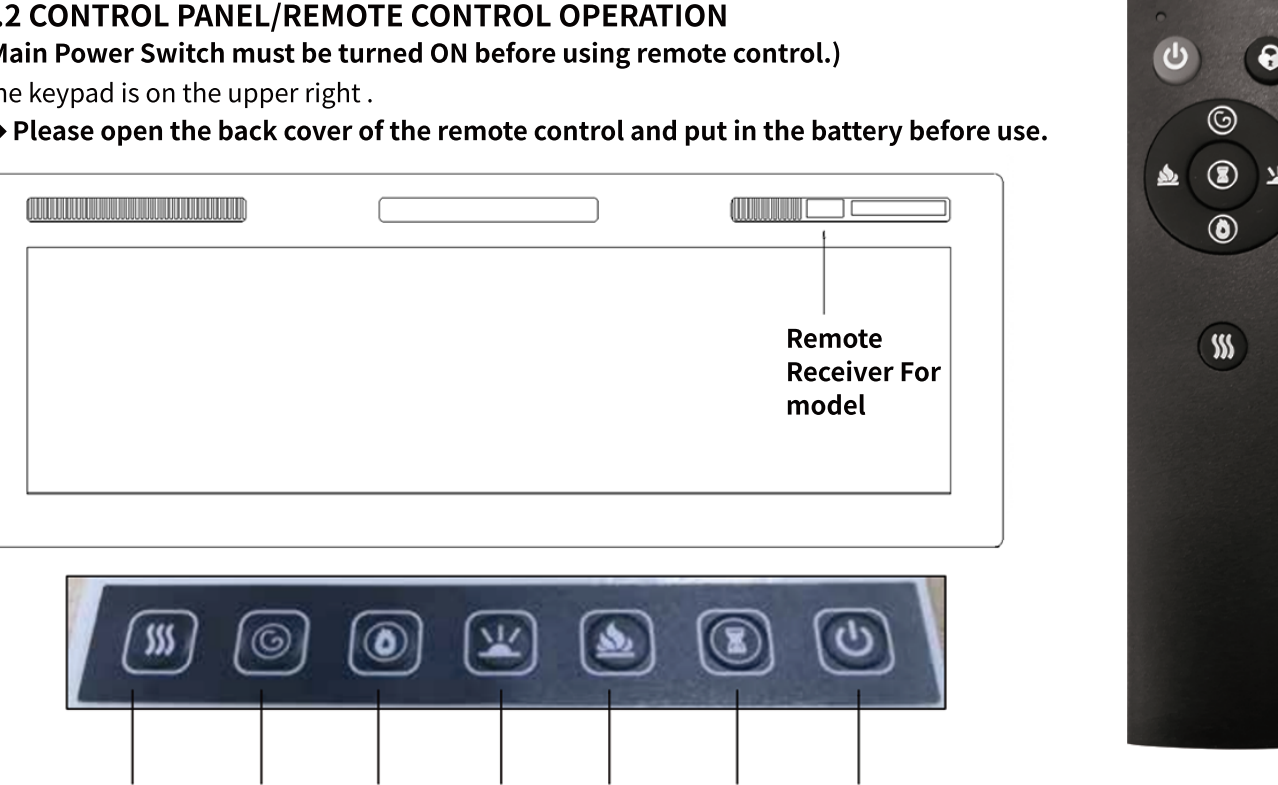

Heater Flame Speed Dimmer Flame Red Color Flame Blue Color Timer Power ON/OFF

POWER: Plug the power plug into a two-prong electrical outlet. The remote control is generally used every time you operate the heater. The remote control is used to control the heater. The remote control is used to control the heater. The remote control is used to control the heater.

FLAME COLOR: Press the flame color button to select the flame color. The flame color can be selected between red, blue, and white. The flame color can be selected between red, blue, and white.

FLAME BED COLOR: Press the flame bed color button to select the flame bed color. The flame bed color can be selected between red, blue, and white. The flame bed color can be selected between red, blue, and white.

CHILD LOCK: Press the child lock button to lock the remote control. The child lock can be selected between on and off. The child lock can be selected between on and off.

HEATER: Press the heater button to turn the heater on or off. The heater can be selected between on and off. The heater can be selected between on and off.

TIMER: Press the timer button to set the timer. The timer can be selected between on and off. The timer can be selected between on and off.

FLAME SPEED: Press the flame speed button to select the flame speed. The flame speed can be selected between low, medium, and high. The flame speed can be selected between low, medium, and high.

18

6.0 TROUBLE SHOOTING GUIDE

| PROBLEM | SOLUTION |
|--|---|
| The mounting bracket cannot be removed. | 1. The mounting bracket is not attached. Unhook the two screws at both sides of the bracket. The bracket will be removed. 2. If the problem still not solved, please contact us via Amazon Message or message. |
| The control panel functions do not work. | 1. Make sure the Power Switch on the control panel is turned on before operation. 2. Check the power supply cord is plugged into a properly grounded outlet. 3. The problem still not solved, please contact us via Amazon Message. |
| Appliance power stopped during the heating process. | 1. Don't cover the appliance. 2. Check the plug, wait for 15 minutes and try to open it again. 3. The problem still not solved, please contact us via Amazon Message. |
| The appliance does not heat or the heat is not enough. | This reason: The face blow and/or the appliance gradually heats up. The fans blow after the appliance turn off to cool the appliance and prevent overheating. |
| The appliance does not turn on and off. | 1. Main power supply switch off. Turn the main power supply switch to "ON" position. 2. The problem still not solved, please contact us via Amazon Message. |
| The appliance does not turn on and off. | 1. Make sure the power cord is plugged into a properly grounded outlet. 2. Check the power supply cord is plugged into a properly grounded outlet. 3. The problem still not solved, please contact us via Amazon Message. |
| The appliance does not turn on and off. | 1. Power cord or power plug not plugged in properly. Contact a qualified electrician to replace power cord or power plug. 2. The problem still not solved, please contact us via Amazon Message. |
| Appliance wiring. | Check all wiring for loose connections. Contact a qualified electrician. |
| Heater does not heat or the heat is not enough. | 1. Make sure the power cord is plugged into a properly grounded outlet. 2. Check the power supply cord is plugged into a properly grounded outlet. 3. The problem still not solved, please contact us via Amazon Message. |
| Flame color is not correct. | 1. Check the flame color button is pressed correctly. 2. The problem still not solved, please contact us via Amazon Message. |

19

5.0 OPERATING INSTRUCTION

5.3 REMOTE CONTROL

PLEASE OPEN THE COVER OF THE REMOTE CONTROL AND PUT IN THE BATTERY BEFORE USE.

PLEASE OPEN THE COVER OF THE REMOTE CONTROL AND PUT IN THE BATTERY BEFORE USE.

PLEASE OPEN THE COVER OF THE REMOTE CONTROL AND PUT IN THE BATTERY BEFORE USE.

20

7.0 MAINTENANCE

DISCONNECT POWER AND ALLOW HEATER TO COOL BEFORE ATTEMPTING ANY MAINTENANCE OR CLEANING TO REDUCE THE RISK OF FIRE, ELECTRIC SHOCK OR DAMAGE TO PERSONS.

THE FIREPLACE SHOULD NOT BE OPERATED WITH AN ACCUMULATION OF DUST OR DIRT ON OR IN THE UNIT. AS THIS CAN CAUSE A BUILD UP OF HEAT AND SUBSEQUENT EVENTUAL DAMAGE. FOR THIS REASON THE HEATER MUST BE INSPECTED REGULARLY, DEPENDING ON CONDITIONS AND AT LEAST AT YEARLY INTERVALS.

7.1 PARTIALLY REFLECTIVE GLASS CLEANING

The partially reflective glass is cleaned in the factory during the assembly operation. During shipment, installation, handling, etc., the partially reflective glass may collect dust particles; these can be removed by dusting lightly with a clean dry cloth. To remove fingerprints or other marks, the partially reflective glass can be cleaned with a damp cloth. This partially reflective glass should be completely dried with a lint-free cloth to prevent water spots. To prevent scratching, do not use abrasive cleaners.

21

7.2 SCHEMATIC DIAGRAM

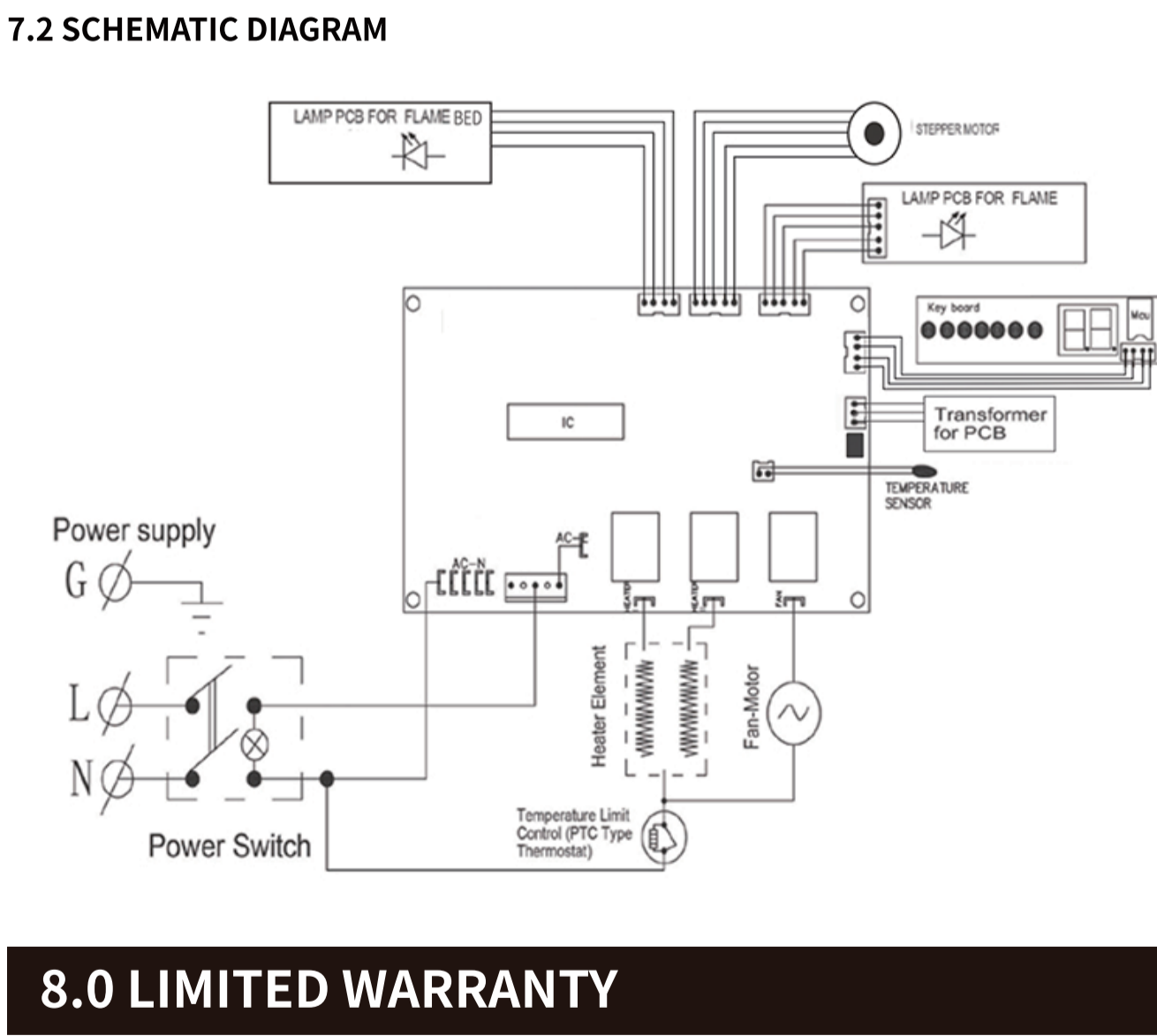

Power supply
Power Switch

22

8.0 LIMITED WARRANTY

This warranty is the original purchaser that this product is free from defects in material and workmanship as of the date of purchase but that it, under normal use and proper care, remains so for one year from the date of purchase. Missing or initially defective parts will be replaced free of charge during the period of this limited warranty.

If parts are unavailable, comparable replacement of refund will be given. The original dated sales receipt is required for all warranty claims. This warranty does not cover damage which has occurred during transport from the point of purchase to the consumer's home. This warranty does not cover glass, light bulbs, batteries, transportation, labor, or other issues not associated with the manufacture of the product.

This product is for residential use only. Any and all commercial use of this product voids all warranties, and frees the manufacturer from all liability.

23

Read and understand all assembly and operating instructions, and all safety information and warnings, before use. The following will void this warranty: Damage caused from tampering with, modifying, or altering the fireplace insert in any manner, Damage due to incorrect assembly, improper care, misuse, or abuse, Damage from being used with the wrong power source, Water damage, Damage caused from this insert being used outdoors; Damage caused from this insert being used for excessive periods of time; Damage caused by the insert being used in a commercial application; Damage from use as a primary heat source: Other misuse or abuse not specifically listed herein.

This product is not intended to be used as a primary heat source; it is for supplemental heating purposes only.

9.0 O&A AND CONTACT INFORMATION

Confuzzled? Email Our Customer Service At:
 YouTube: BREEZEHEAT
 CONTACT INFO: wolflontech1@gmail.com

Please feel free to send us the text or email. We will reply to you within 24 hours. Also please feel free to contact us if you have received the defective items.

Follow our YouTube Channel then you will be able to find our assembling video as a pinned video.

24

7.0 MAINTENANCE

DISCONNECT POWER AND ALLOW HEATER TO COOL BEFORE ATTEMPTING ANY MAINTENANCE OR CLEANING TO REDUCE THE RISK OF FIRE, ELECTRIC SHOCK OR DAMAGE TO PERSONS.

THE FIREPLACE SHOULD NOT BE OPERATED WITH AN ACCUMULATION OF DUST OR DIRT ON OR IN THE UNIT. AS THIS CAN CAUSE A BUILD UP OF HEAT AND SUBSEQUENT EVENTUAL DAMAGE. FOR THIS REASON THE HEATER MUST BE INSPECTED REGULARLY, DEPENDING ON CONDITIONS AND AT LEAST AT YEARLY INTERVALS.

7.1 PARTIALLY REFLECTIVE GLASS CLEANING

The partially reflective glass is cleaned in the factory during the assembly operation. During shipment, installation, handling, etc., the partially reflective glass may collect dust particles; these can be removed by dusting lightly with a clean dry cloth. To remove fingerprints or other marks, the partially reflective glass can be cleaned with a damp cloth. This partially reflective glass should be completely dried with a lint-free cloth to prevent water spots. To prevent scratching, do not use abrasive cleaners.

25

8.0 LIMITED WARRANTY

This warranty is the original purchaser that this product is free from defects in material and workmanship as of the date of purchase but that it, under normal use and proper care, remains so for one year from the date of purchase. Missing or initially defective parts will be replaced free of charge during the period of this limited warranty.

If parts are unavailable, comparable replacement of refund will be given. The original dated sales receipt is required for all warranty claims. This warranty does not cover damage which has occurred during transport from the point of purchase to the consumer's home. This warranty does not cover glass, light bulbs, batteries, transportation, labor, or other issues not associated with the manufacture of the product.

This product is for residential use only. Any and all commercial use of this product voids all warranties, and frees the manufacturer from all liability.

26

9.0 O&A AND CONTACT INFORMATION

Confuzzled? Email Our Customer Service At:
 YouTube: BREEZEHEAT
 CONTACT INFO: wolflontech1@gmail.com

Please feel free to send us the text or email. We will reply to you within 24 hours. Also please feel free to contact us if you have received the defective items.

Follow our YouTube Channel then you will be able to find our assembling video as a pinned video.

27

SAVE THESE INSTRUCTIONS

These instructions should be carefully read before installation. The booklet must be kept and delivered to the new user. The Manufacturer reserves the right to vary the features of the product without prior notice. The technical data are indicative only.

28

HELP CENTER

Question about your product? We're here to help. Visit us at:

Chat Support Product Inquiry Orders FAQ Product Assembly Returns & Refunds

We Stand Behind the Quality of The Fireplace

1. If you have any issues with your item, please let us know! We will always do our best to come up with a solution that you will be happy with.
2. Please get in touch with our customer service team before returning the product.
3. Please do not throw away the original box(es) if you have not finished assembling and confirmed no quality issues.

Length of return period:
 You can return items within 30 days of purchase.
 In the meanwhile, everything you purchased from us comes with a one-year warranty.

Who is responsible for the return shipping fee:
 We will cover the return shipping fee in materials or workmanship. For example, torn wicker or misaligned screw holes. We will send you a prepaid shipping label after you send us photos or videos of the defect.
 You item has been damaged in transit. For example, glass is broken or product is damaged. We will send you a prepaid shipping label after you send us photos of the damage.
 3. You receive the wrong box(es) due to a warehouse error. We will send you a prepaid shipping label after you send us photos of the wrong SKU numbers on the outer box(es).
 4. One or more boxes are lost in transit. We will send you a prepaid shipping label if you no longer want the item.

* However, we still hope to work with you for a better solution instead of a return. Please don't hesitate to contact our customer service team.

29

Customer will cover the return shipping fees if:

1. You don't like the product(s) after receiving the box(es).
2. You no longer need the product(s) but you have received the box(es).
3. You buy the product(s) by mistake but you have received the box(es).
4. Order/shipment cancellation failed and you have received the box(es).

Return Request
 In order to get a full refund as described in this return policy, all items must be in original condition and undamaged. The return period is 30 days from the date of purchase. (2) When return all accessories and parts are firmly packed in all original packaging. If your return does not meet the requirements, you may not get a full refund.

When will be refunded?
 The refund is released once the goods have been returned to our warehouse. What if the product is damaged/defective outside of the valid return period? We want you to be a happy customer. Please reach out to us by email and we will come up with a solution to make sure you are satisfied.

30

CONTACT INFORMATION

Confuzzled? Email Our Customer Service At:
 YouTube: BREEZEHEAT
 CONTACT INFO: wolflontech1@gmail.com

Please feel free to send us the text or email. We will reply to you within 24 hours. Also please feel free to contact us if you have received the defective items.

Follow our YouTube Channel then you will be able to find our assembling video as a pinned video.

31

SAVE THESE INSTRUCTIONS

These instructions should be carefully read before installation. The booklet must be kept and delivered to the new user. The Manufacturer reserves the right to vary the features of the product without prior notice. The technical data are indicative only.

32

HELP CENTER

Question about your product? We're here to help. Visit us at:

Chat Support Product Inquiry Orders FAQ Product Assembly Returns & Refunds

We Stand Behind the Quality of The Fireplace

1. If you have any issues with your item, please let us know! We will always do our best to come up with a solution that you will be happy with.
2. Please get in touch with our customer service team before returning the product.
3. Please do not throw away the original box(es) if you have not finished assembling and confirmed no quality issues.

Length of return period:
 You can return items within 30 days of purchase.
 In the meanwhile, everything you purchased from us comes with a one-year warranty.

Who is responsible for the return shipping fee:
 We will cover the return shipping fee in materials or workmanship. For example, torn wicker or misaligned screw holes. We will send you a prepaid shipping label after you send us photos or videos of the defect.
 Your item has been damaged in transit. For example, glass is broken or product is damaged. We will send you a prepaid shipping label after you send us photos of the damage.
 3. You receive the wrong box(es) due to a warehouse error. We will send you a prepaid shipping label after you send us photos of the wrong SKU numbers on the outer box(es).
 4. One or more boxes are lost in transit. We will send you a prepaid shipping label if you no longer want the item.

* However, we still hope to work with you for a better solution instead of a return. Please don't hesitate to contact our customer service team.